

QUADRA-FIRE®

CB1200-I PELLET INSERT

Owner's Manual Installation and Operation

Model:
CB1200MI-MBK

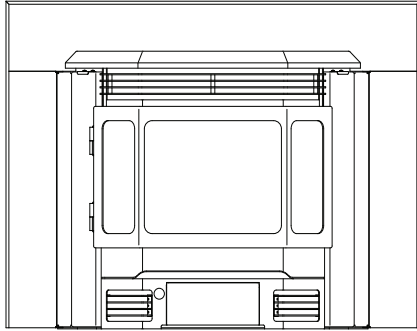

Tested and Listed by  Portland Oregon USA
C US
OMNI-Test Laboratories, Inc.

member of

Pellet Fuels Institute
www.pelletheat.org

NOTICE



DO NOT DISCARD THIS MANUAL

- Important operating and maintenance instructions included.
- Read, understand and follow these instructions for safe installation and operation.
- Leave this manual with party responsible for use and operation.



WARNING



Please read this entire manual before installation and use of this pellet fuel-burning room heater. Failure to follow these instructions could result in property damage, bodily injury or even death.

- Do not store or use gasoline or other flammable vapors and liquids in the vicinity of this or any other appliance.
- Do not overfire - If any external part starts to glow, you are overfiring. Reduce feed rate. Overfiring will void your warranty.
- Comply with all minimum clearances to combustibles as specified. Failure to comply may cause house fire.

WARNING



HOT SURFACES!

Glass and other surfaces are hot during operation AND cool down.

Hot glass will cause burns.

- Do not touch glass until it is cooled
- NEVER allow children to touch glass
- Keep children away
- CAREFULLY SUPERVISE children in same room as fireplace.
- Alert children and adults to hazards of high temperatures.

High temperatures may ignite clothing or other flammable materials.

- Keep clothing, furniture, draperies and other flammable materials away.

CAUTION

Tested and approved for wood pellets and shelled field corn fuel only. Burning of any other type of fuel voids your warranty.

CAUTION

Check building codes prior to installation.

- Installation MUST comply with local, regional, state and national codes and regulations.
- Consult local building, fire officials or authorities having jurisdiction about restrictions, installation inspection, and permits.

Congratulations

and Welcome to the Quadra-Fire Family!

Hearth & Home Technologies welcomes you to our tradition of excellence! In choosing a Quadra-Fire appliance, you have our assurance of commitment to quality, durability, and performance.

This commitment begins with our research of the market, including 'Voice of the Customer' contacts, ensuring we make products that will satisfy your needs. Our Research and Development facility then employs the world's most advanced technology to achieve the optimum operation of

our stoves, inserts and fireplaces. And yet we are old-fashioned when it comes to craftsmanship. Each unit is meticulously fabricated and surfaces are hand-finished for lasting beauty and enjoyment. Our pledge to quality is completed as each model undergoes a quality control inspection. From design, to fabrication, to shipping:

We wish you and your family many years of enjoyment in the warmth and comfort of your hearth appliance. Thank you for choosing Quadra-Fire.

NOTE: Consult insurance carrier, local building inspector, fire officials or authorities having jurisdiction over restrictions, installation inspection and permits.

**CLEARANCE TO COMBUSTIBLES LABEL LOCATED INSIDE HOPPER LID
SERIAL NUMBER & MANUFACTURE DATE LABEL LOCATED UNDER TOP ON INSIDE OF HOPPER BODY**



CAUTION: HOT WHILE IN OPERATION DO NOT TOUCH. KEEP CHILDREN, CLOTHING AND FURNITURE AWAY. CONTACT MAY CAUSE SKIN BURNS. SEE NAMEPLATE AND INSTRUCTIONS. Operate this unit with fuel hopper lid closed. Failure to do so may result in emissions products' combustion from the hopper under certain conditions. Maintain hopper seal in good condition. Do no over fill the hopper.

ATTENTION: CHAUD LORS DE L'OPÉRATION. NE PAS TOUCHER. GARDEZ LES ENFANTS ET LES VÊTEMENTS LOIN DE L'ESPACE DÉSIGNÉ DE L'INSTALLATION. LE CONTACT PEUT CAUSER DES BRÛLURES À LA PEAU. VOIR L'ÉTIQUETTE ET LES INSTRUCTIONS. Opérez cet appareil avec le couvercle de la trémie fermé. Le défaut de ne pas suivre les instructions peut résulter, sous certaines conditions, en une combustion des émissions des produits venant de la trémie. Ne pas remplir la trémie trop pleine.

Test Lab & Report No.

Safety and clearance section located on inside of hopper lid./Serial Number section located under top on inside of hopper body.
La section se réfère aux distances et mesures de sécurité est située à l'intérieur du couvercle de la trémie à feu. La section du numéro de série est située en dessous du couvercle à l'intérieur de la trémie.

Tested and Listed by **OMNI-TEST** Portland Oregon USA Report / Rapport #061-S-13-2
OMNI-Test Laboratories, Inc.

QUADRA-FIRE
1200-I Pellet Insert

HEARTH & HOME TECHNOLOGIES
1445 Highway North, Colville, WA 99114
www.quadrafire.com

Model Name

Listed Solid Fuel Room Heater/Pellet Type Insert. Also suitable for Mobile Home Installation. This appliance has been tested and listed for use in Manufactured Homes in accordance with OAR 814-23-9000 through 814-23-9009.

Appareil de chauffage inséré de combustible solide/de type de boulettes. Accepté dans l'installation dans les maisons mobiles. Cet appareil a été testé et enregistré pour l'usage dans les Maisons mobiles en accord avec OAR 814-23-9000 jusqu'à 814-23-9009.

Tested to: ASTM E1509-95, UL127, ULC S628-93, ULC S610-M87, ULC/ORD C1482-M1990, Room Heating Pellet Burning Type, (UM) 84-HUD FOR USE ONLY WITH PELLETTIZED WOOD OR SHELLED FIELD CORN FUEL.

Testé à: ASTM E1509-95, UL127, ULC628-M93, ULC S610-M87, ULC/ORD C1482-M1990, Room Heating Pellet Burning Type, (UM) 84-HUD POUR USAGE AVEC LES BOULETTES DE BOIS OU DE COMBUSTIBLE DE MAIS ÉCOSSÉ DES CHAMPS.

Input Rating Maximum 5.5 lb fuel/hr.
Electrical Rating: 115 VAC, 60 Hz, Start 4.1 Amps, Run 1.1 AMPS.
Route power cord away from unit. Do not route cord under or in front of appliance.

Consommation maximale à l'heure (sans pertes) 2.5 kg/h.
Puissance Électrique: 115 VAC, 60 Hz, Début 4.1 Amps, Courir 1.1 Amps, Éloignez le fil électrique de l'appareil. Ne pas faire passer le fil électrique au dessus de l'appareil.

DANGER: Risk of electrical shock. Disconnect power supply before servicing. Replace glass only with 5mm ceramic available from your dealer. To start, set thermostat above room temperature, the stove will light automatically. To shutdown, set thermostat to below room temperature. For further instruction refer to owner's manual. Keep viewing and ash doors tightly closed during operation.

DANGER: Il y a un risque de décharge électrique. Déconnectez le fil électrique de la prise de contact avant le service. Remplacez la vitre seulement avec une vitre céramique de 5 mm disponible chez votre fournisseur. Pour allumer, monter la température du thermostat au dessus de la température de la pièce, le poêle s'allumera automatiquement. Pour éteindre, descendre la température du thermostat en dessous de la température de la pièce. Pour des instructions supplémentaires référez vous au manuel du propriétaire. Gardez la porte d'ouverture et la porte des cendres fermées hermétiquement durant l'opération.

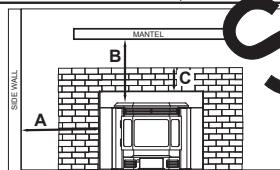
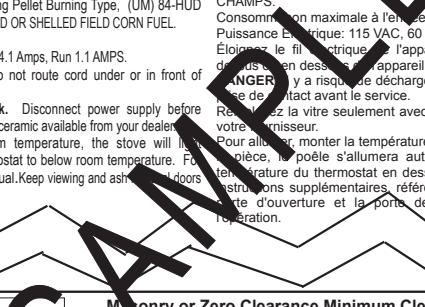

Masonry or Zero Clearance Minimum Clearances to Combustible
Machennene ou zéro distance foyer distances minimales à tout matériel combustible.

A	Couverts to combustible wall	6" (152mm)	A	Lucarne au mur combustible	152mm
B	Insert top to mantel	12" (305mm)	B	Dessus de l'insert à la tablette de cheminée	305mm
C	Front Facing	3" (76mm)	C	Revêtement facial	76mm
D*	Hearth Extension - Front	6" (152mm)	D*	Protection de sol - frontal	152mm
E*	Hearth Extension - Side	8" (203mm)	E*	Protection de sol - côté	203mm

*See hearth protection note above *Voir les notes sur la protection ole sol ci-dessus.

Manufactured Date

U.S. ENVIRONMENTAL PROTECTION AGENCY OMNI Test Laboratories, Inc., Beaverton, Or Report/Rapport 061-S-12-2
This model is exempt from EPA certification under 40 CFR 60.531 by definition [Wood Heater (A) 'Air-to-Fuel Ratio'].

QUADRA-FIRE
1200-I PELLETT INSERT
SERIAL NO. / NUMERO DU
007C
7014-080C

Serial Number

2009 2010 2011 JAN FEB MAR APR MAY JUNE JULY AUG SEPT OCT NOV DEC
DO NOT REMOVE THIS LABEL / NE PAS ENLEVER L'ÉTIQUETTE Made in China/Fait Aux Chine

Safety Alert Key:

- **DANGER!** Indicates a hazardous situation which, if not avoided will result in death or serious injury.
- **WARNING!** Indicates a hazardous situation which, if not avoided could result in death or serious injury.
- **CAUTION!** Indicates a hazardous situation which, if not avoided, could result in minor or moderate injury.
- **NOTICE:** Indicates practices which may cause damage to the fireplace or to property.

TABLE OF CONTENTS

Section 1: Listing and Code Approvals

- A. Appliance Certifications 4
- B. Mobile Home Approved 4
- C. Glass Specifications..... 4
- D. Electrical Rating 4
- E. BTU & Efficiency Specifications 4

Section 2: Getting Started

- A. Design, Installation & Location Considerations..... 5
- B. Locating Your Appliance & Chimney ..6
- C. Thermostat Location 6
- D. Draft..... 6
- E. Negative Pressure 6
- B. Fire Safety 7
- C. Tools & Supplies Needed 7
- D. Inspect Appliance, Components and Pre-Check List 7

Section 3: Dimensions & Clearances

- A. Appliance Dimensions 8
- B. Clearances to Combustibles As A Built-In, UL and ULC 9
- C. Clearances to Combustibles, Masonry & Zero Clearance..... 10
- D. Minimum Opening for Factory Built Fireplace 10
- E. Masonry Minimum Opening..... 10
- F. Floor Protection 10
- G. Calculating Alternate Floor Protection Material..... 11
- H. Prefabricated Metal Chimney 11
- I. Removing Floor of Factory Built Fireplace 12
- J. Altering Factory-Built Fireplace..... 12

Section 4: Vent Information

- A. Chimney & Exhaust Connections 13
- B. Venting Termination Requirements 13
- C. Equivalent Feet of Pipe..... 14
- D. Pipe Selection Chart..... 14

Section 5: Venting Systems

- A. Full Reline with Outside Air-Horizontal 15
- B. Full Reline with Outside Air-Vertical.... 16

Section 6: Mobile Home..... 17

Section 7: Appliance Set-Up

- A. Rear Shroud Installation 18-19
- B. Outside Air Kit..... 20
- C. Adjustable Hopper Option..... 20
- D. Grille Installation 20
- E. Adjustable Hearth Support..... 21
- F. Panel & Trim 22-23
- G. Brick Set Installation 24
- H. Brick Clip Installation..... 24
- I. Log Set Placement..... 25
- J. Thermostat Installation..... 25

Section 8: Operating Instructions

- A. Fuel Size, Material & Storage 26
- B. General Operation Information 27
- C. Before Your First Fire 27
- D. Starting Your First Fire..... 27
- E. Fire Characteristics..... 28
- F. Feed Rate Adjustment 28
- G. Ignition Cycles 28
- H. Frequently Asked Questions..... 29

Section 9: Troubleshooting 31-32

Section 10: Maintaining & Servicing Appliance

- A. Proper Shutdown Procedure..... 33
- B. Quick Reference Maintenance Chart.. 33
- C. General Maintenance & Cleaning 33-36
- D. High Ash Content Maintenance 37
- E. Glass Replacement..... 38
- F. Igniter Replacement..... 39
- G. Baffle Removal..... 39

Section 12: Reference Material

- A. Component Functions..... 40-41
- B. Component Locations..... 42
- C. Exploded Drawings..... 43
- D. Service Parts & Accessories..... 44-48
- E. Service & Maintenance Log..... 49
- E. Warranty Policy..... 50-51
- F. Contact Information 52

1

Listing and Code Approvals

A. Appliance Certification

MODEL:	1200-I Pellet Insert
LABORATORY:	OMNI Test Laboratories, Inc
REPORT NO.	061-S-13-2
TYPE:	Solid Fuel Room Heater/Pellet Fuel Burning Type Insert
STANDARD:	ASTM E1509-95, ULC S628-93, ULC S610-M87, ULC S628-M93 and ULC/ORD-C1482-M1990 Room Heater Pellet Fuel Burning Type and (UM) 84-HUD, Mobile Home Approved

B. Mobile Home Approved

This appliance is approved for mobile home installations when not installed in a sleeping room and when an outside combustion air inlet is provided. The structural integrity of the mobile home floor, ceiling, and walls must be maintained.

The appliance must be properly grounded to the frame of the mobile home and use only listed pellet vent, Class "L" or "PL" connector pipe. A Quadra-Fire Outside Air Kit must be installed in a mobile home installation.

Note: This appliance is also approved for installation into a shop.

C. Glass Specifications

This appliance is equipped with 5mm ceramic glass. Replace glass only with 5mm ceramic glass. Please contact your dealer for replacement glass.

NOTE: This installation must conform with local codes. In the absence of local codes you must comply with the **ASTM E1509-95, ULC S628-93, ULC S610-M87, ULC/ORD-C-1482-M1990, (UM) 84-HUD.**

D. Electrical Rating

115 VAC, 60 Hz, Start 4.1 Amps, Run 1.1 Amps

E. BTU & Efficiency Specifications

Emissions Rating:	.9 grams/hr
*BTU Output:	14,000 - 40,000 / hr
Heating Capacity:	up to 2,500 sq. ft. depending on climate zone
Hopper Capacity:	60-75 lbs
Fuel:	Wood Pellets or Shelled Corn
Shipping Weight:	243 lbs

*BTU output will vary, depending on the brand of fuel you use in your appliance. Consult your Quadra-Fire dealer for best results.

WARNING! Risk of Fire! *Hearth & Home Technologies disclaims any responsibility for, and the warranty and agency listing will be voided by the above actions.*

DO NOT:

- Install or operate damaged appliance
- Modify appliance
- Install other than as instructed by *Hearth & Home Technologies*
- Operate the appliance without fully assembling all components
- Overfire
- Install any component not approved by *Hearth & Home Technologies*
- Install parts or components not Listed or approved.

Improper installation, adjustment, alteration, service or maintenance can cause injury or property damage.

For assistance or additional information, consult a qualified installer, service agency or your dealer.

NOTE: *Hearth & Home Technologies, manufacturer of this appliance, reserves the right to alter its products, their specifications and/or price without notice.*

Quadra-Fire is a registered trademark of *Hearth & Home Technologies.*

2

Getting Started

A. Design, Installation & Location Considerations

1. Appliance Location

NOTICE: Check building codes prior to installation.

- Installation MUST comply with local, regional, state and national codes and regulations.
- Consult insurance carrier, local building inspector, fire officials or authorities having jurisdiction over restrictions, installation inspection and permits.

It is a good idea to plan your installation on paper, using exact measurements for clearances and floor protection, before actually beginning the installation

Consideration must be given to:

- Safety, convenience, traffic flow
- Placement of the chimney and chimney connector.
- If you are not using an existing chimney, place the appliance where there will be a clear passage for a factory-built listed chimney through the ceiling and roof.
- Installing an optional outside air kit would affect the location of the vent termination.

Since pellet exhaust can contain ash, soot or sparks, you must consider the location of:

- Windows
- Air Intakes
- Air Conditioner
- Overhang, soffits, porch roofs, adjacent walls
- Landscaping, vegetation

When locating vent and venting termination, vent above roof line when possible.

Warning! Risk of Fire Damaged parts could impair safe operation. Do NOT install damaged, incomplete or substitute components.

CAUTION! If burning shelled field corn, you must use approved venting specifically designed for corn to prevent corrosion or degradation. Follow the instructions from the venting manufacturer.

NOTICE: Locating the appliance in a location of considerable air movement can cause intermittent smoke spillage from appliance. Do not locate appliance near:

- Frequently open doors
- Central heat outlets or returns

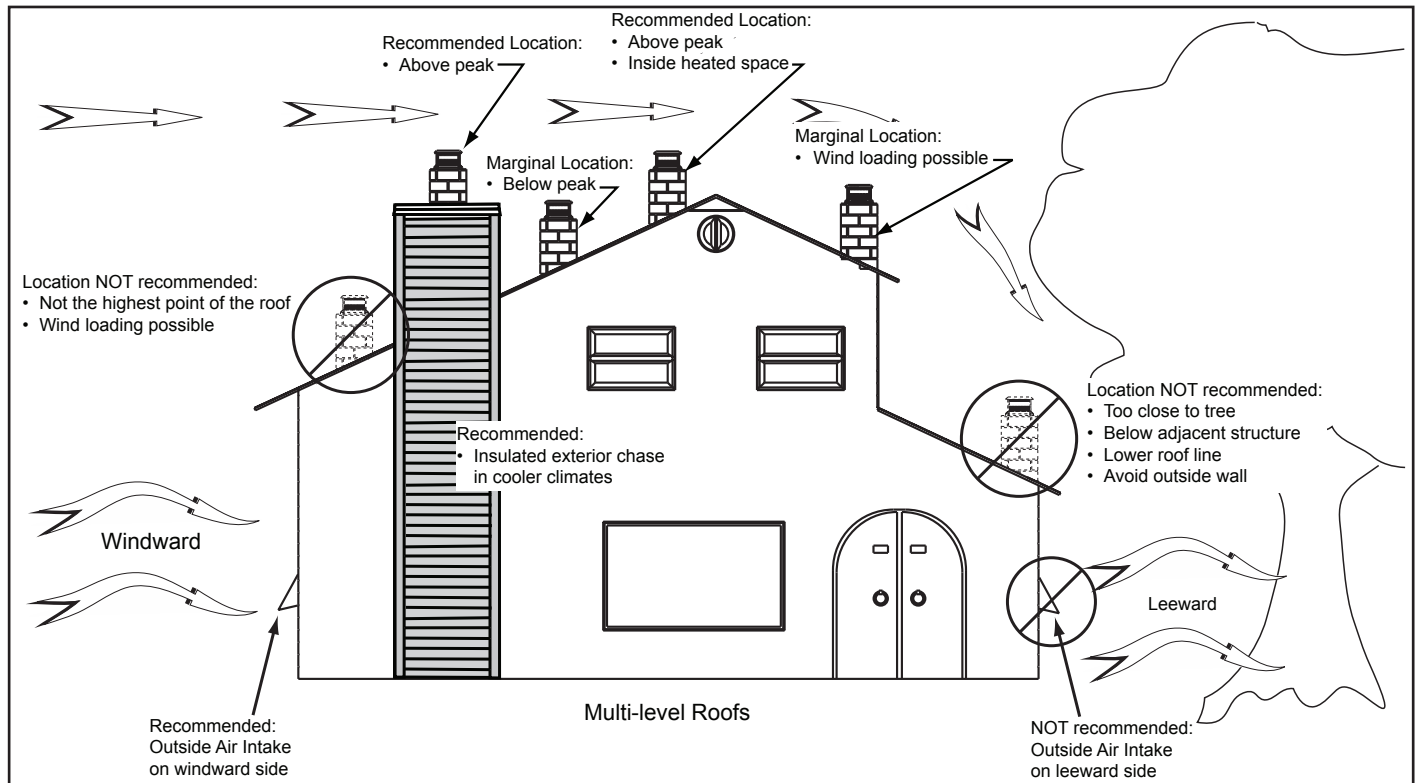

Figure 5.1

B. Locating Your Appliance & Chimney

Location of the appliance and chimney will affect performance.

- Install through the warm airspace enclosed by the building envelope. This helps to produce more draft, especially during lighting and die-down of the fire.
- Penetrate the highest part of the roof. This minimizes the effects of wind loading.
- Locate termination cap away from trees, adjacent structures, uneven roof lines and other obstructions.
- Minimize the use of chimney offsets.
- Consider the appliance location relative to floor and ceiling and attic joists.
- Take into consideration the termination requirements on **Page 11**.

 CAUTION
<ul style="list-style-type: none"> • DO NOT CONNECT THIS UNIT TO A CHIMNEY FLUE SERVICING ANOTHER APPLIANCE. • DO NOT CONNECT TO ANY AIR DISTRIBUTION DUCT OR SYSTEM.

C. Thermostat Location

The thermostat’s location will have some effect on the appliance’s operation. When the thermostat is located close to the appliance, it may require a slightly higher temperature setting to keep the rest of the house comfortable. If the thermostat location is in an adjacent room or on a different floor level, you will notice higher temperatures near the appliance.

D. Draft

Draft is the pressure difference needed to vent appliances successfully. When an appliance is drafting successfully, all combustion byproducts are exiting the home through the chimney.

Considerations for successful draft include:

- Preventing negative pressure
- Location of appliance and chimney

NOTICE: *Hearth & Home Technologies assumes no responsibility for the improper performance of the chimney system caused by:*

- *Inadequate draft due to environmental conditions*
- *Downdrafts*
- *Tight sealing construction of the structure*
- *Mechanical exhausting devices*

E. Negative Pressure

WARNING! Risk of Asphyxiation! *Negative pressure can cause spillage of combustion fumes and soot.*



Negative pressure results from the imbalance of air available for the appliance to operate properly. It can be strongest in lower levels of the house.

Causes include:

- Exhaust fans (kitchen, bath, etc.)
- Range hoods
- Combustion air requirements for furnaces, water heaters and other combustion appliances
- Clothes dryers
- Location of return-air vents to furnace or air conditioning
- Imbalances of the HVAC air handling system
- Upper level air leaks such as:
 - Recessed lighting
 - Attic hatch
 - Duct leaks

To minimize the effects of negative air pressure:

- Install the outside air kit with the intake facing prevailing winds during the heating season
- Ensure adequate outdoor air for all combustion appliances and exhaust equipment
- Ensure furnace and air conditioning return vents are not located in the immediate vicinity of the appliance
- Avoid installing the appliance near doors, walkways or small isolated spaces
- Recessed lighting should be a “sealed can” design
- Attic hatches weather stripped or sealed
- Attic mounted duct work and air handler joints and seams taped or sealed

 WARNING
<div style="display: flex; align-items: center;">  <div> <p>Fire Hazard.</p> <ul style="list-style-type: none"> • Do not operate appliance before reading and understanding operating instructions. • Failure to operate appliance properly may cause a house fire. </div> </div>



F. Fire Safety

To provide reasonable fire safety, the following should be given serious consideration:



- Install at least one smoke detector on each floor of your home.
- Locate smoke detector away from the heating appliance and close to the sleeping areas.
- Follow the smoke detector manufacturer’s placement and installation instructions and maintain regularly.
- Conveniently locate a Class A fire extinguisher to contend with small fires.
- In the event of a hopper fire:
 - Evacuate the house immediately.
 - Notify fire department.

G. Tools And Supplies Needed

Tools and building supplies normally required for installation, unless installing into an existing masonry fireplace:	
Reciprocating Saw	Safety Glasses
Channel Locks	Framing Square
Hammer	Electric Drill & Bits (1/4")
Phillips Screwdriver	1/4" Self-Tapping Screws
Tape Measure	
Plumb Line	<u>May also need:</u>
Level	Vent Support Straps
Framing Material	Venting Paint
Hi-temp Caulking Material	
Gloves	

	 WARNING
	<p>Inspect appliance and components for damage. Damaged parts may impair safe operation.</p> <ul style="list-style-type: none"> • Do NOT install damaged components. • Do NOT install incomplete components. • Do NOT install substitute components. <p>Report damaged parts to dealer.</p>

H. Inspect Appliance & Components and Pre-Use Check List

	 WARNING
	<p>Fire Risk.</p> <p>Hearth & Home Technologies disclaims any responsibility for, and the warranty will be voided by, the following actions:</p> <ul style="list-style-type: none"> • Installation and use of any damaged appliance. • Modification of the appliance. • Installation other than as instructed by Hearth & Home Technologies. • Installation and/or use of any component part not approved by Hearth & Home Technologies. • Operating appliance without fully assembling all components. • Operating appliance without legs attached (if supplied with unit). • Do NOT Overfire <p>Or any such action that may cause a fire hazard.</p>

1.		Place the appliance in a location near the final installation area and follow the procedures below:
2.		Open the appliance and remove all the parts and articles packed inside the Component Pack. Inspect all the parts and glass for shipping damage. Contact your dealer if any irregularities are noticed.
3.		All safety warnings have been read and followed.
4.		This Owner’s Manual has been read.
5.		Floor protection requirements have been met.
6.		Venting is properly installed.
7.		The proper clearances from the appliance and chimney to combustible materials have been met.
8.		The masonry chimney is inspected by a professional and is clean, or the factory built metal chimney is installed according to the manufacturer’s instructions and clearances.
9.		The chimney meets the required minimum height.
10.		All labels have been removed from the glass door.
11.		Plated surfaces have been wiped clean, if applicable.
12.		Thermostat or remote has been installed.
13.		A power outlet is available nearby.

3 Dimensions and Clearances

A. Appliance Dimensions

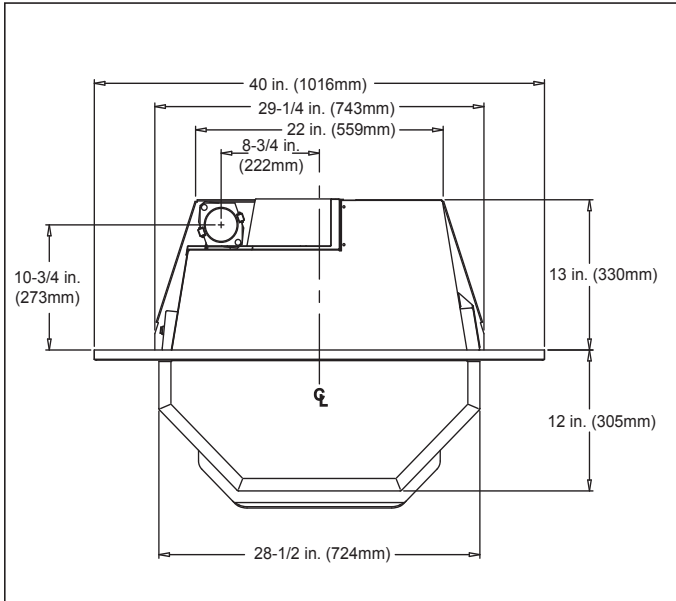

Figure 7.1 - Top View

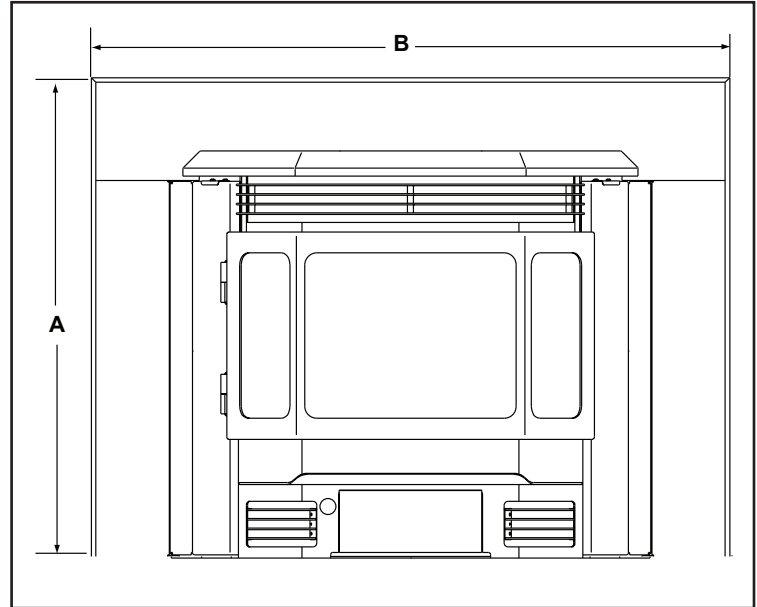

Figure 7.2 - Front View

Panel	A	B
Standard	30 inches (762mm)	40 inches (1016mm)
Large	33 inches (838mm)	50 inches (1270mm)

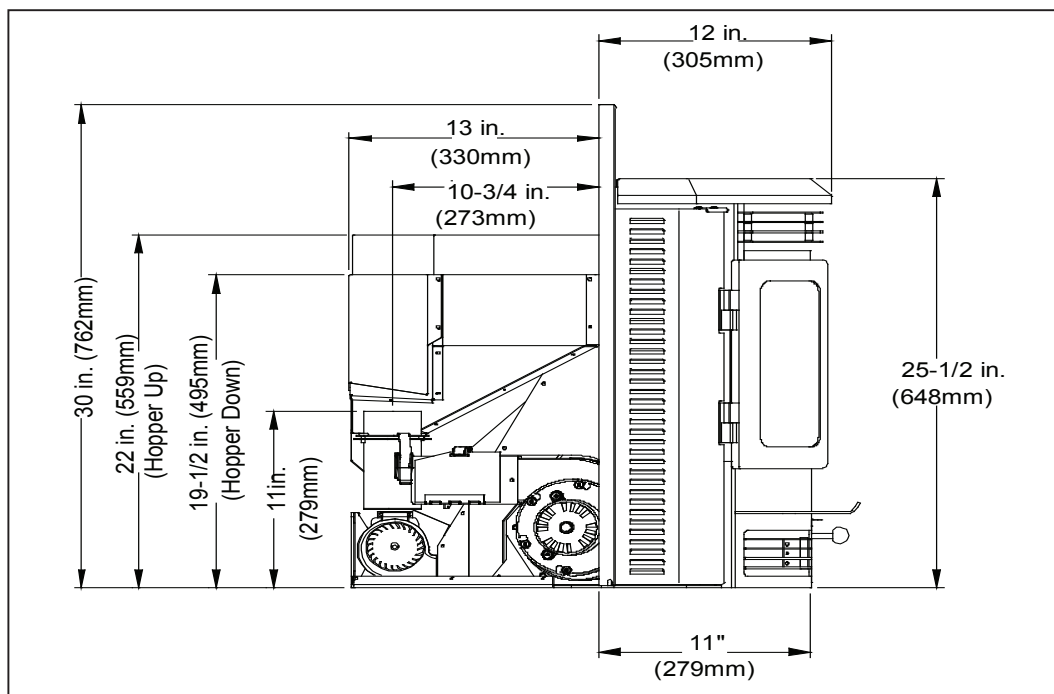

Figure 7.3 - Side View

B. Clearance To Combustibles, UL and ULC

AS A BUILT-IN

Rear Shroud Kit is Required for Built-In Installation

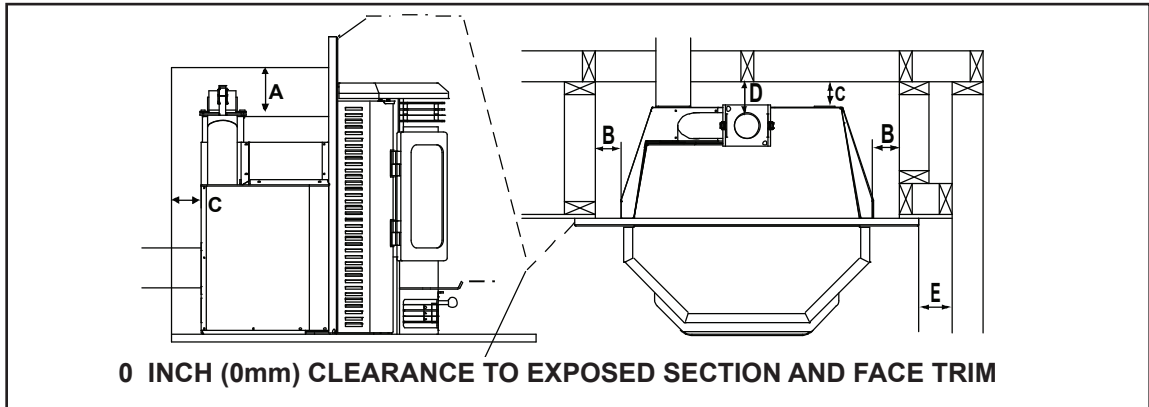

Figure 9.1

A	Top of Shroud	Top Vent	3.0	76
		Rear Vent	0	0
B	Sides of Inside Shroud	Top or Rear Vent	0	0
C	Back of Inside Shroud	Top Vent	2.5	64
		Rear Vent	0	0
D	Vent Pipe to Combustible	Top or Rear Vent	3.0	76

**INSTALLED AS A BUILT-IN UNIT
Shown with Rear Vent and Optional Outside Air**

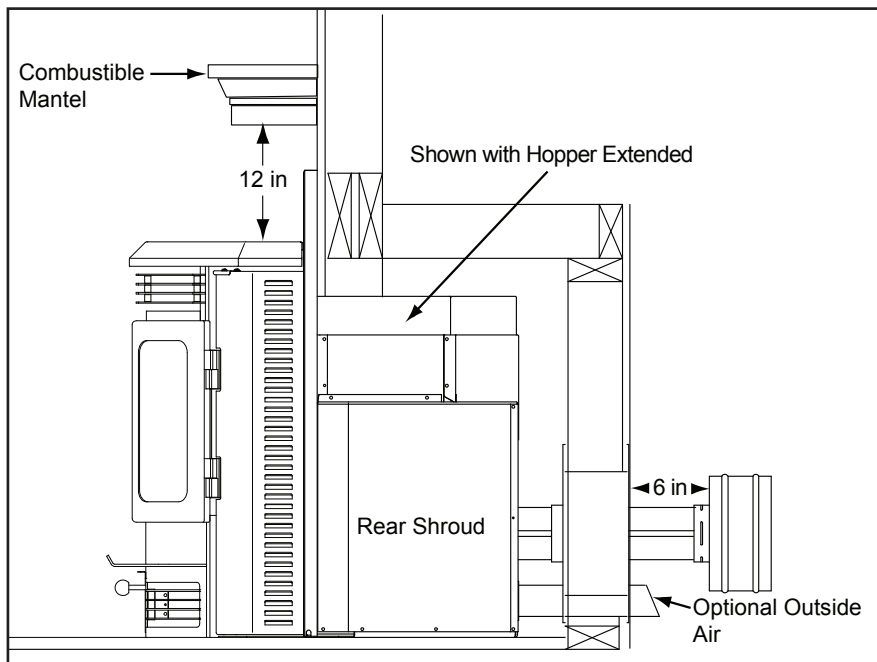

Figure 9.2

NOTICE:

Please note that while the minimum clearance for the termination cap is 6 inches (152mm) there is the possibility of soot buildup around the termination area. If this occurs we suggest to move the termination further away from the house to prevent it.



WARNING



Fire Risk.

Comply with all minimum clearances to combustibles as specified.

Failure to comply may cause house fire.

NOTE:

- Illustrations reflect typical installations and are **FOR DESIGN PURPOSES ONLY**.
- Illustrations/diagrams are not drawn to scale.
- Actual installation may vary due to individual design preference.

C. Minimum Clearances To Combustibles for Masonry and Zero Clearance Fireplaces

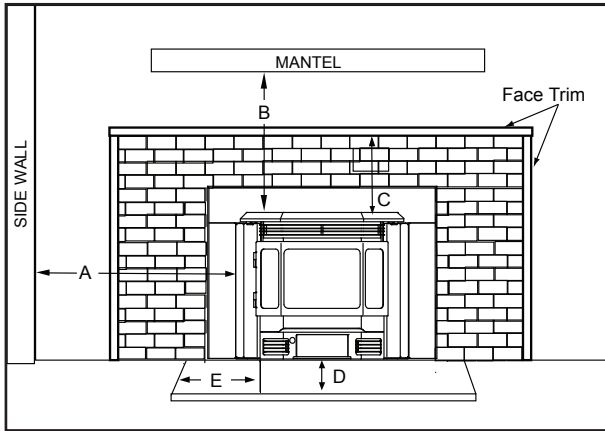

Figure 10.1

		Inches	Millimeters
A	Louvers to combustible side wall	6	153
B	Insert top to mantel	12	305
C	Top to Face Trim	3	76
D	Hearth Extension - Front	6	153
E	Hearth Extension - Sides	8	203

D. Minimum Opening for Masonry and Zero Clearance Fireplaces for Built-In Using Rear Shroud

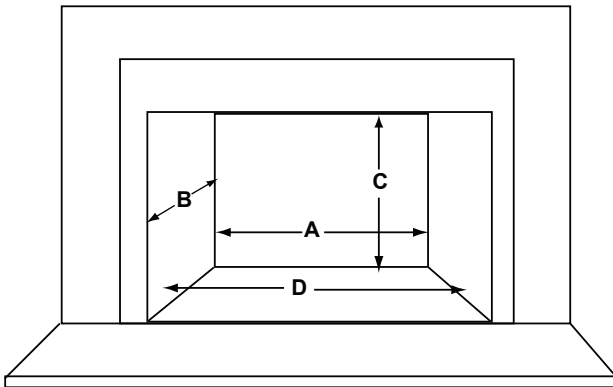
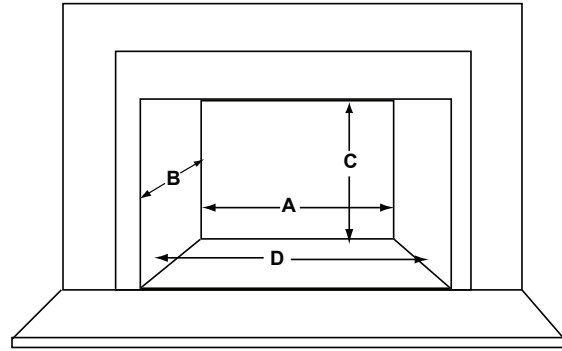

Figure 10.2

		Inches	Millimeters
A	Rear Width	22	558
B	Depth	15-1/2	393
C*	Height - Top Vent	25-1/2	647
	Height - Rear Vent	22-1/2	571
D	Front Width	29-1/4	743

*The size of your floor protector choice must be added to this dimension. If using Quadra-Fire floor protector, Part 811-0730, allow 1-1/2 inches (38mm).

E. Masonry Minimum Opening



	Location	Inches	Millimeters
A	Rear Width	22	558
B	Depth	13	330
C	Height - Top Vent	19-1/2	495
D	Front Width	29-1/4	743

F. Floor Protection

1. Zero Clearance Installations*

It is necessary to install a floor protection of non-combustible material with a R value of 3.0 (1 inch [25mm] minimum thickness with a “k” value of 0.58) or a 1 inch (25mm) air space between insert base and hearth.

2. Non-Zero Clearance Installations*

A non-combustible floor protector is required with a minimum R value of 3.0 (1 inch [25mm] minimum thickness with a “k” value of 0.58) extending 6 inches (153mm) in front of the insert and 8 inches (203mm) to each side of the door opening.

* See alternate floor protection worksheet.

NOTE: A Quadra-Fire floor protector (Part 811-0730) is available through your dealer to be used as a floor protector for the section under the insert body only. Floor protection to front and sides of insert unit must be supplied in addition to this part.

G. Calculating Alternate Floor Protection Material

Thermal Conductivity: k value

The k value indicates the amount of heat (in BTU's) that will flow in 1 hour through 1 square foot of a uniform material 1 inch thick for each degree (F) of temperature difference from one side of the material to the other. The LOWER the k factor means less heat is being conducted through the non-combustible material to the combustible material beneath it. The k value of a material must be equal or smaller then the required k value to be acceptable.

$$\frac{\text{(BTU) (inch)}}{\text{(foot}^2 \text{ (hour) (}^\circ\text{F)}}$$

Thermal Resistance: R value

The R value is a measure of a material's resistance to heat transfer. R value is convenient when more than one material is used since you can add the R values together, whereas you can not do this for k value. The HIGHER the R factor means less heat is being conducted through the non-combustible material to the combustible material beneath it. The R value of a material must be equal or larger then the required R value to be acceptable.

Converting k to R:

Divide 1 by k and multiply the results times the thickness in inches of the material.

$$R = 1/k \times \text{inches of thickness}$$

Converting R to k:

Divide the inches of thickness by R.

$$k = \text{inches of thickness}/R$$

Calculations:

Example: Floor protection requires k value of 0.84 and 3/4 inch thick.

Alternative material has a k value of 0.6 and is 3/4 inch thick.

Divide 0.6 by .75 = k value of 0.80. This k value is smaller than 0.84 and therefore is acceptable.

H. Prefabricated Metal Chimney

The chimney can be new or existing, masonry or prefabricated and must meet the following minimum requirements:

- Must be minimum 6 inch (152mm) inside diameter of high temperature chimney listed to UL 103 HT (2100°F) or ULC-S628.
- Must use components required by the manufacturer for installation.
- Must maintain clearances required by the manufacturer for installation.
- Refer to manufacturers instructions for installation
- This insert is listed to UL 1482 Standard and is approved for installation into listed factory-built zero clearance fireplaces listed to UL 127 conforming to the following specifications and instructions:
- The original factory-built clearance fireplace chimney cap must be re-installed after installing the approved chimney liner meeting type UL 103 HT requirements (2100°F) per UL 1777.
- If the chimney is not listed as meeting HT requirements, or if the factory built fireplace was tested prior to 1998, a full height listed chimney liner must be installed from the appliance flue collar to the chimney top.
- The liner must be securely attached to the insert flue collar and the chimney top.
- The air flow of the factory-built zero-clearance fireplace system must not be altered. The flue liner top support attachment must not reduce the air flow for the existing air-cooled chimney system.
- No dilution air is allowed to enter the chimney.
 1. Secure the fireplace damper in the open position. If this cannot be accomplished, it will be necessary to remove the damper
 2. Seal damper area of chimney around chimney connector with a high temperature sealant or seal insert against the face of the fireplace.
 3. Both methods must be removable and replaceable for cleaning and re-installation.

I. Removing Metal Floor of Factory-Built Firebox

- The firebrick (refractory), glass doors, screen rails, screen mesh and log grates can be removed from a factory-built firebox in order to gain minimum insert opening requirements.
- Any smoke shelves, shields and baffles may be removed from a factory-built firebox if attached with mechanical fasteners.
- The metal floor of the factory-built firebox may be removed to facilitate the installation of the insert only when a 1 inch (25mm) airspace is provided between the insert and the floor of outer wrap.
- If the floor is made of thin metal, we recommend using a Quadra-Fire floor protector, Part 811-0730, which is available through your dealer.

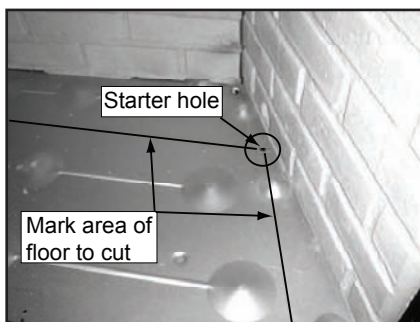

Figure 12.1. Measure and mark the metal floor for cutting. With a drill, make a starter hole in each corner.



Figure 12.2. Using a sawz-all, cut out the floor.

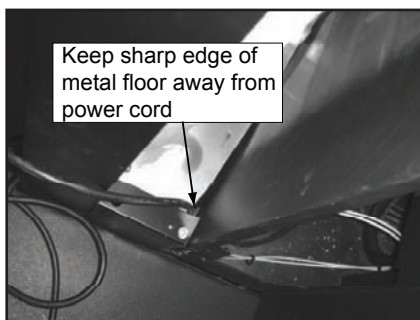

Figure 12.3. Place the insert into the factory-built firebox. Ensure that the power cord can not be damaged by the sharp metal edge. You may need to cut out a notch to accommodate the cord.

J. Altering the Factory-Built Fireplace

- The fireplace must not be altered, except for the exceptions listed below. Do not removal the bricks and mortar from the existing fireplace.

The following modifications are premissible:

- Removal of damper or locked in open position
- Removal of smoke shelf or baffle
- Removal of ember catches
- Removal of fire grate
- Removal of view screen/curtain
- Removal of doors
- External trim pieces which do not affect the operation of the fireplace may be removed providing they can be stored on or within the fireplace for reassembly if the insert is removed.
- The permanent metal warning label provided must be attached to the back of the fireplace, with screws or nails, stating that the fireplace may have been altered to accommodate the insert, and must be returned to original condition for use as a conventional fireplace. **Figure 12.4.**
- If the hearth extension is lower than the fireplace opening, the portion of the insert extending onto the hearth must be supported.
- Manufacturer designed adjustable support kit can be ordered from your dealer.
- Final approval of this installation type is contingent upon the authority having jurisdiction.

NOTE: Refer to chimney liner manufacturer for recommendations on supporting the liner. Installation into fireplaces without a permit will void the listing

WARNING! Risk of Fire!

Follow venting manufacturer's clearances and instructions when installing venting system.

NOTICE: In Canada when using a factory-built chimney it must be safety listed, **Type UL103 HT (2100°F) [1149°C] CLASS "A"** or conforming to **CAN/ULC-S629M, STANDARD FOR 650°C FACTORY-BUILT CHIMNEYS.**

WARNING

THIS FIREPLACE MAY HAVE BEEN ALTERED TO ACCOMMODATE AN INSERT. IT MUST BE RETURNED TO ITS ORIGINAL CONDITION BEFORE USE AS A SOLID FUEL BURNING FIREPLACE.

250-2061

Figure 12.4

4 Vent Information

A. Chimney and Exhaust Connection

1. **Chimney & Connector:** Use 3 or 4 inch (76-102mm) diameter type "L" or "PL" venting system. It can be vented vertically or horizontally.
2. **Mobile Home:** Approved for all Listed pellet vent. If using the 3 inch (76mm) vertical Top Vent Adapter Kit or the 3 to 6 inch (76-152mm) Top Vent Offset Adapter, use Listed double wall flue connector. A Quadra-Fire Outside Air Kit must be used with manufactured home installations.
3. **Residential:** The 3 inch (76mm) vertical Top Vent Adapter Kit and the 3 to 6 inch (76-152mm) Top Vent Offset Adapter are tested to use 24 gauge single wall flue connector or Listed double wall flue connector to Class A Listed metal chimneys, or masonry chimneys meeting International Conference of Building Officials (ICBO) standards for solid fuel appliances.
4. **INSTALL VENT AT CLEARANCES SPECIFIED BY THE VENT MANUFACTURER.**
5. Secure exhaust venting system to the appliance with at least 3 screws. Also secure all connector pipe joints with at least 3 screws through each joint.
6. **DO NOT INSTALL A FLUE DAMPER IN THE EXHAUST VENTING SYSTEM OF THIS UNIT.**
7. **DO NOT CONNECT THIS UNIT TO A CHIMNEY FLUE SERVING ANOTHER APPLIANCE.**

NOTE: All pipe must be welded seam pipe whenever possible. Seal pipe joints with high temperature silicone (500°F [260°C] minimum rated only). Do not put silicone inside of pipe.

NOTE: If burning shelled field corn, you must use approved venting specifically designed for corn. Follow the instructions from the venting manufacturer.

B. Venting Termination Requirements

CAUTION

Do not terminate vent in any enclosed or semi-enclosed area such as a carport, garage, attic, crawl space, under a sun deck or porch, narrow walkway or closely fenced area, or any location that can build up a concentration of fumes such as a stairwell, covered breezeway, etc.

1. Termination must exhaust above air inlet elevation. It is recommended that at least 60 inches (1.5m) of vertical pipe be installed when appliance is vented directly through a wall. This will create a natural draft, which will help prevent the possibility of smoke or odor venting into the home during a power outage. It will also keep exhaust from causing a nuisance or hazard by exposing people or shrubs to high temperatures. The safest and preferred venting method is to extend the vent vertically through the roof.
2. Distance from doors and opening windows, or gravity or ventilation air inlets into building:
 - a. Not less than 48 inches (1.2m) below;
 - b. Not less than 48 inches (1.2m) horizontally from;
 - c. Not less than 12 inches (305mm) above.
3. Distance from permanently closed windows:
 - a. Not less than 12 inches (305mm) below, horizontally from or above.
4. Distance between bottom of termination and grade should be 12 inches (305mm) minimum. This is conditional upon plants in the area, and nature of grade surface. The grade surface must be a non-combustible material (i.e., rock, dirt). The grade surface must not be lawn. Distance between bottom of termination and public walkway should be 84 inches (2.1m) minimum.
5. Distance to combustible materials must be 24 inches (610mm) minimum. This includes adjacent buildings, fences, protruding parts of the structure, roof overhang, plants and shrubs, etc.
6. Termination Cap Location (Home Electrical Service)
 - Side-to-side clearance is to be the same as minimum clearance to vinyl inside corners.
 - Clearance of a termination cap below electrical service shall be the same as minimum clearance to vinyl soffits.
 - Clearance of a termination cap above electrical service will be 12 inches (305mm) minimum.
 - Location of the vent termination must not obstruct or interfere with access to the electrical service.



WARNING



Fire Hazard.

- Only LISTED venting components may be used.
- NO OTHER vent components may be used. Substitute or damaged vent components may impair safe operation.



WARNING



Vent surfaces get HOT, can cause burns if touched. Noncombustible shielding or guards may be required.

C. Equivalent Feet of Pipe

The table below can help you calculate the equivalent feet of pipe which is a method used to determine pellet vent size. See **Figure 14.1**.

⚠ WARNING

Improper installation, adjustment, alteration, service or maintenance can cause injury or property damage. Refer to the owner's information manual provided with this appliance. For assistance or additional information consult a qualified installer, service agency or your dealer.

Example of 3 Elbow-Rear Vent Termination Calculation

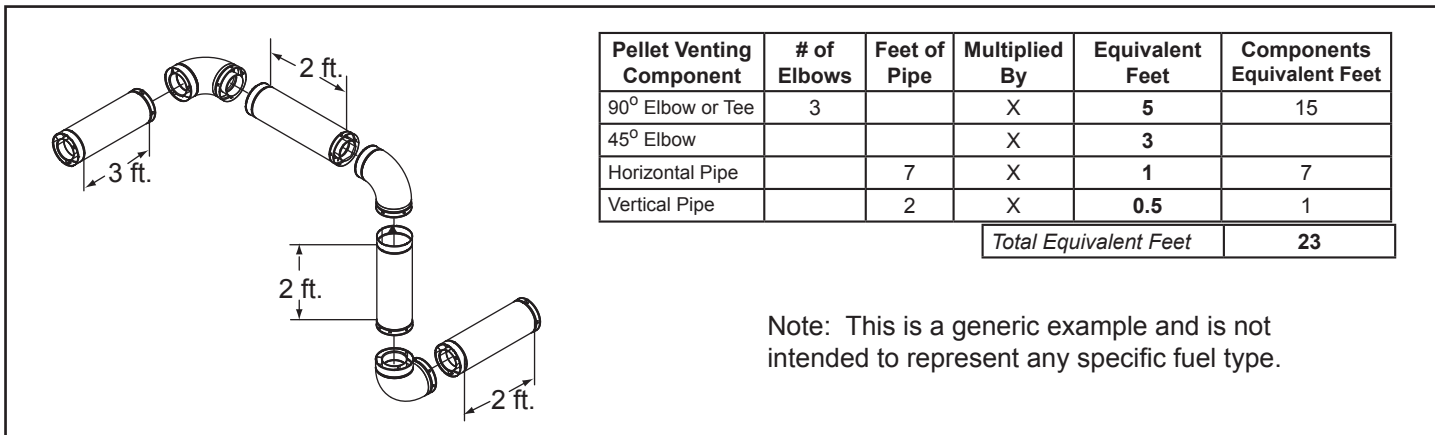

Note: This is a generic example and is not intended to represent any specific fuel type.

Figure 14.1

D. Pipe Selection Chart

The chart will help you in determining proper venting size according to the equivalent feet of pipe calculated above and the altitude above sea level of this installation. See **Figure 14.2**.

Locate the calculated equivalent feet of pipe on the vertical left side of the chart. Move to the right horizontally on the chart until you reach your altitude above sea level.

If you fall below the diagonal line, 3 or 4 inch (76 to 102mm) pipe may be used. If it is anywhere above the diagonal line, a 4 inch (102mm) diameter pipe is required.

The chart reveals that a 90° elbow is 5 times as restrictive to the flow of exhaust gases under positive pressure as 1 foot of horizontal pipe, and a foot of horizontal pipe is twice as restrictive as a foot of vertical pipe.

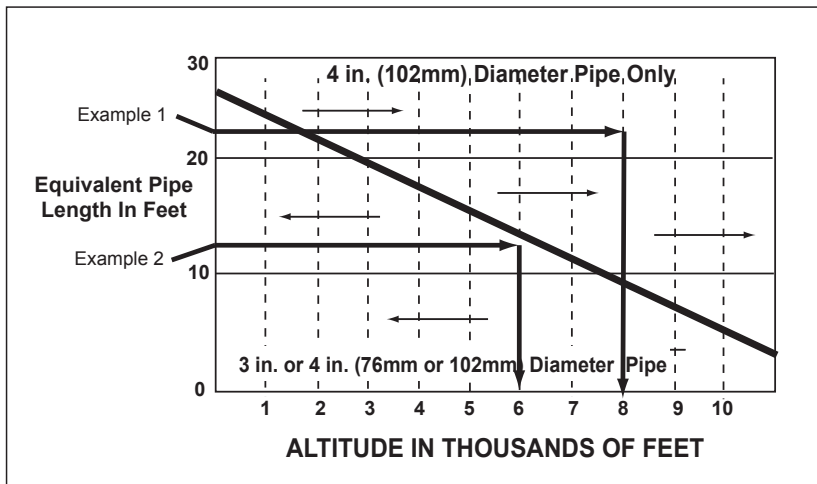

Figure 14.2

Example 1: If the equivalent length of pipe is 23 feet with altitude of 8,000 feet you must use 4 inch (102mm) diameter type "L" or "PL" vent.

Example 2: If the equivalent length of pipe is 12 feet with altitude of 6,000 feet you may use 3 or 4 inch (76 to 102mm) diameter type "L" or "PL" vent

⚠ WARNING

Fire Risk.

Do NOT pack insulation or other combustibles between firestops.

- ALWAYS maintain specified clearances around venting and firestop systems.
- Install firestops as specified.

Failure to keep insulation or other material away from vent pipe may cause fire.

5 Venting Systems

A. Full Reline With Outside Air - Horizontal

CAUTION

Never draw outside combustion air from:

- Wall, floor or ceiling cavity
- Enclosed space such as an attic or garage

 **WARNING**

Fire Risk.
Inspection of Chimney:

- Masonry chimney must be in good condition.
- Meets minimum standard of NFPA 211
- Factory-built chimney must be a minimum 6 inch (152mm) UL103 HT.

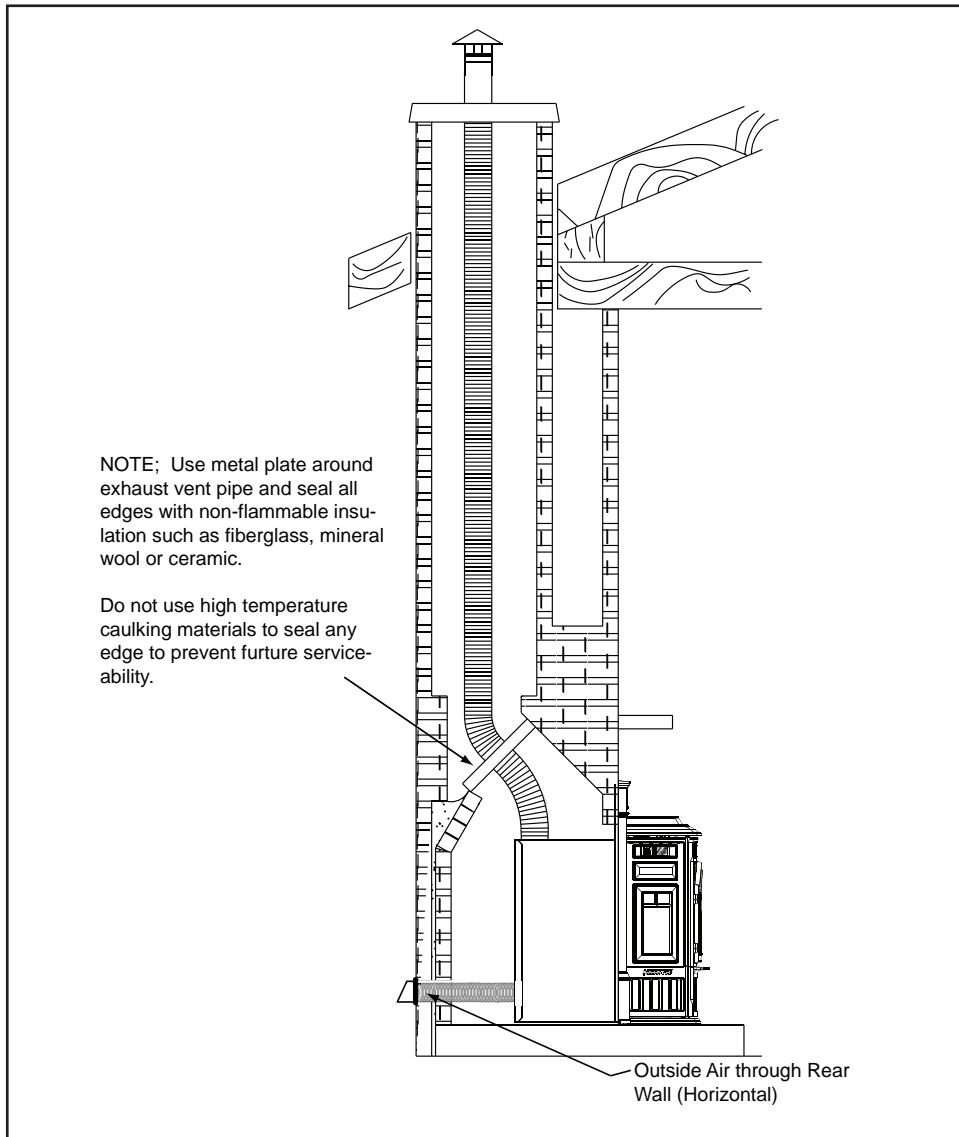

Figure 15.1

NOTE:
In Canada, where passage through a wall or partition of combustible construction is desired, the installation shall conform to CAN/CSA-B365.

NOTE:

- Illustrations reflect typical installations and are FOR DESIGN PURPOSES ONLY.
- Illustrations/diagrams are not drawn to scale.
- Actual installation may vary due to individual design preference.

B. Full Reline With Outside Air - Vertical

NOTE: Check clearances carefully for this type of installation to ensure adequate room for outside air venting.

NOTE: In Canada only a full reline is allowed per ULC S628, ORD ULC C1482-M1990.

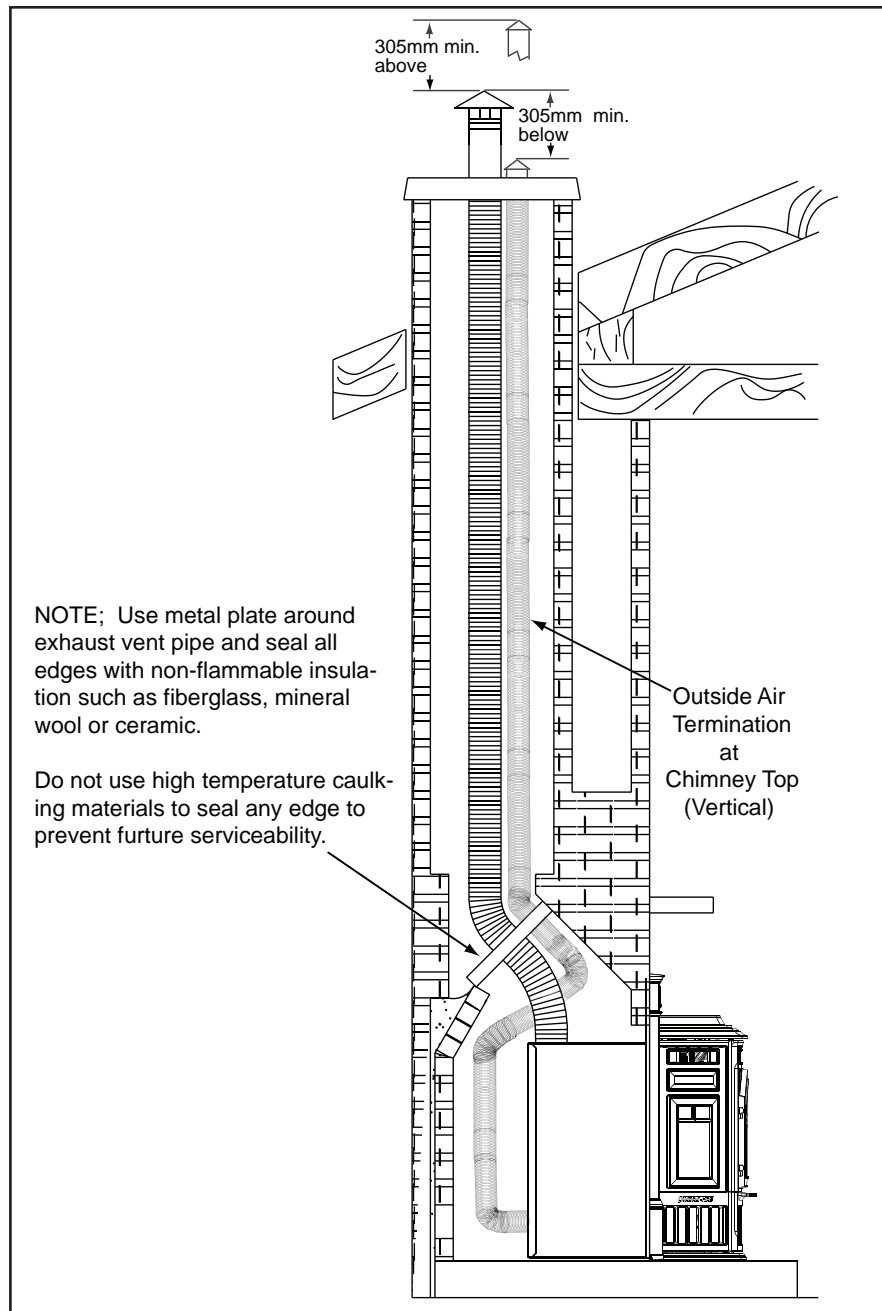

Figure 16.1

NOTE: In Canada this fireplace insert must be installed with a continuous chimney liner a 6 inch (152mm) in diameter extending from the fireplace insert to the top of the chimney. The chimney liner must conform to the Class 3 requirements of CAN/ULC-S635, Standard for Lining Systems for Existing Masonry or Factory-Built Chimneys and Vents, or CAN/ULC-S640, Standard for Lining Systems for New Masonry Chimneys.

CAUTION

- Check building codes prior to installation.
- Installation **MUST** comply with local, regional, state and national codes and regulations.
 - Consult local building, fire officials or authorities having jurisdiction about restrictions, installation inspection, and permits.

6 Mobile Home

A. Mobile Home Installation

You must use a Quadra-Fire Outside Air Kit for installation in a mobile home.

1. An outside air inlet must be provided for the combustion air and must remain clear of leaves, debris, ice and/or snow. It must be unrestricted while the appliance is in use to prevent room air starvation which causes smoke spillage. Smoke spillage can also set off smoke alarms.
2. The combustion air duct system must be made of metal. It must permit zero clearance to combustible construction and prevent material from dropping into the inlet or into the area beneath the dwelling and contain a rodent screen.
3. The appliance must be secured to the mobile home structure by bolting it to the floor (using lag bolts). Use the same holes that secured the appliance to the shipping pallet.
4. The appliance must be grounded with #8 solid copper grounding wire or equivalent, terminated at each end with an NEC approved grounding device.
5. Refer to Clearances to Combustibles and floor protection requirements on **pages 9 & 10** for listings to combustibles and appropriate chimney systems.
6. Use silicone to create an effective vapor barrier at the location where the chimney or other component penetrates to the exterior of the structure.
7. Follow the chimney manufacturer's instructions when installing the vent system for use in a mobile home.
8. Installation shall be in accordance with the Manufacturers Home & Safety Standard (HUD) CFR 3280, Part 24.

CAUTION

THE STRUCTURAL INTEGRITY OF THE MOBILE HOME FLOOR, WALL AND CEILING/ROOF MUST BE MAINTAINED

Do NOT cut through:

- Floor joist, wall, studs or ceiling trusses.
- Any supporting material that would affect the structural integrity.

CAUTION

Never draw outside combustion air from:

- Wall, floor or ceiling cavity
- Enclosed space such as an attic or garage

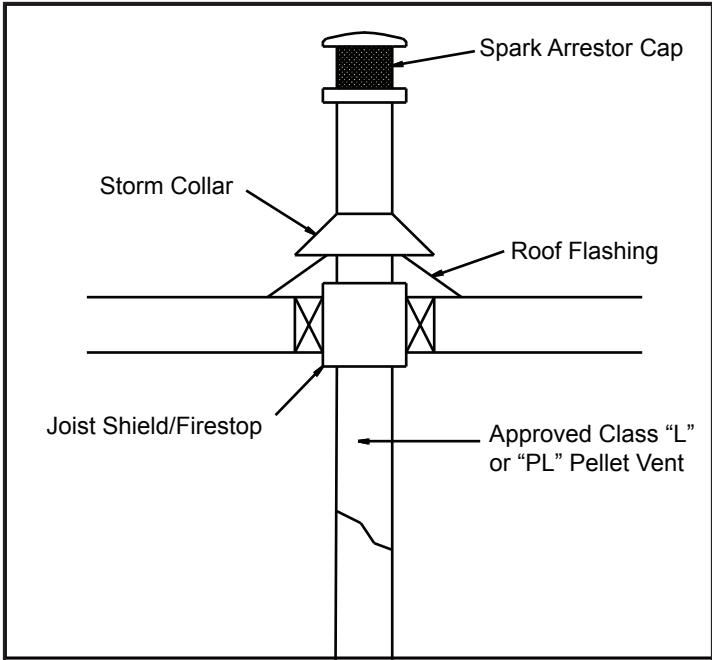

Figure 17.1

⚠ WARNING

Installation must comply with Manufactured Home and Safety Standard (HUD), CFR 3280, Part 24.

⚠ WARNING

Asphyxiation Risk.
NEVER INSTALL IN A SLEEPING ROOM.
 Consumes oxygen in the room.

7 Appliance Set-Up

A. Rear Shroud Installation

1. Top Vent Installations

Parts Required:

Part 811-0680, Rear Shroud Kit.

Includes: Six galvanized steel shroud pieces, two cover plates and fastener package.

Part 811-0650, Rear Shroud Top Vent

Includes: Vent pipe and two 1/4 - 20 x 3/4 inch bolts with nuts.

Part 811-0660, 3 inch Top Vent Adapter or Part 811-0670, 4 inch Top Vent Adapter

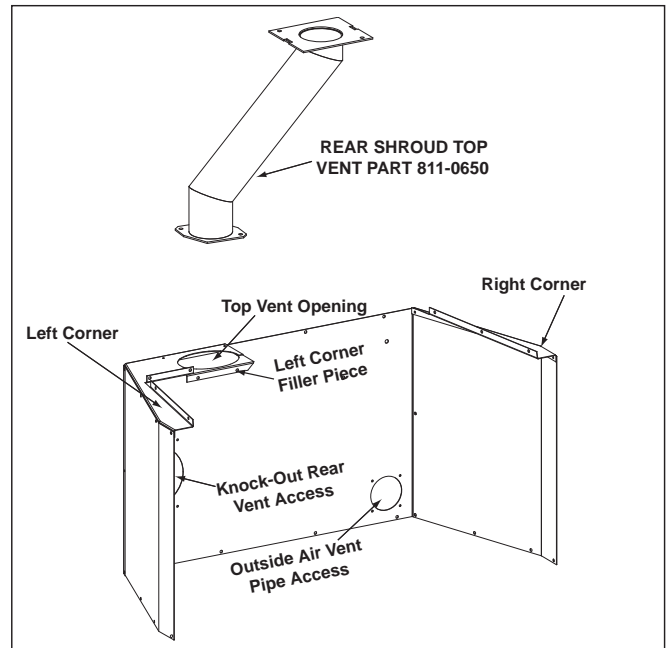

Figure 18.1

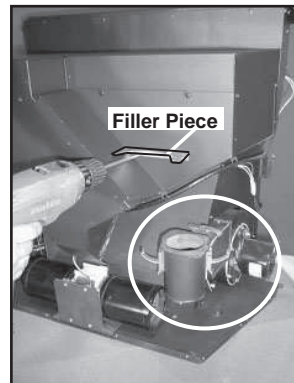

Figure 18.2

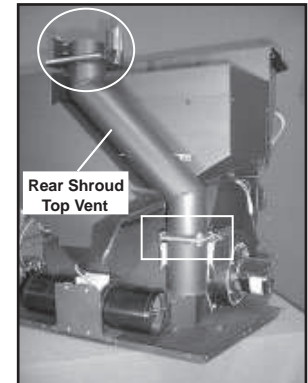

Figure 18.3

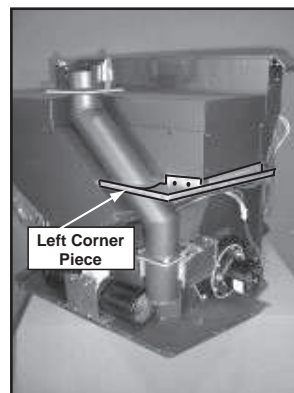

Figure 18.4

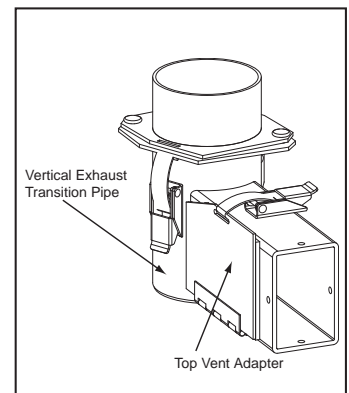

Figure 18.5

Tools Required:

Electric drill, 1/8 inch drill bit, Phillips screw driver, 3/8 inch wrench & 7/16 inch wrench, (7/16 inch socket wrench & high temperature silicone adhesive are also required for rear vent installations).

Complete the following procedures, based on your venting installation, prior to installing the rear shroud kit. (Note: All photos depict top vent installation).

Top Vent Installation Preparation

1. Remove the top vent adapter from the vertical exhaust transition pipe. **Figures 18.2 and 18.5.**
2. Use 2 screws to attach left corner filler piece of rear shroud to the insert hopper. **Figures 18.1 and 18.2.**
3. Use (2) 1/4 - 20 x 3/4 inch bolts with nuts to install rear shroud top vent to the exhaust transition. See boxed area in **Figure 18.3.** (Circled area, top vent adapter, will be installed later).
4. Install the left shroud panel corner at 3 points, 2 screws into back of hopper and 1 down into the filler piece). **Figure 18.4**

Rear Vent Installation Preparation:

1. Remove the ENTIRE exhaust blower housing by removing the 4 nuts using a 7/16 inch socket wrench. Set the nuts aside for later use.
2. Remove the 4 screws and remove the vertical exhaust transition pipe exhaust blower housing.
3. Remove any silicone sealant remaining on the blower housing.
4. Attach the rear vent adapter to the exhaust blower housing with 4 screws. **Figure 19.2.**
5. Apply a bead of high temperature silicone adhesive around the juncture of the blower housing and rear vent adapter, smoothing it around the joint to ensure that a good seal is made.
6. Re-install the exhaust blower housing (now with rear vent adapter attached) with the 4 nuts previously removed in Step 1.
7. Use 2 screws to attach left corner filler piece of rear shroud to the insert hopper. **Figures 18.1 & 18.2 on page 18.**
8. Install the left shroud corner with 2 screws into the hopper body and 1 down into filler piece. **Figure 19.1.**
9. Install cover plate over top vent opening using 4 screws.

4. Assemble the right corner and right panel pieces using 4 screws prior to attaching to insert. **Figure 19.4.**
5. After assembly, attach the right shroud panel/corner piece assembly to the insert with 3 screws across the bottom and 1 on the side. **Figure 19.4.**

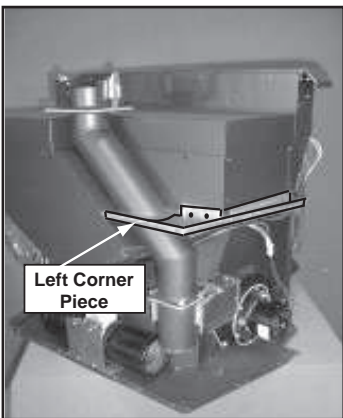

Figure 19.1

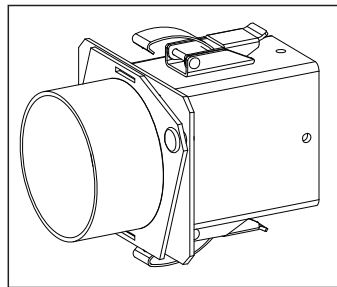

Figure 19.2

Installing Rear Shroud

Top Vent Applications: Leave knock-out plate in place. **Figure 19.3**

Rear Vent Applications: Clip corners of knock-out plate, remove and discard, prior to assembling rear shroud kit.

1. Install rear panel using 4 screws along bottom and 2 screws into the left shroud corner piece at the top. **Figure 19.3.**
2. If your installation does not include an outside air kit, attach cover plate with 4 screws.
3. Attach left shroud panel using seven screws, 3 on top and bottom and 1 along the side. **Figure 19.3.**

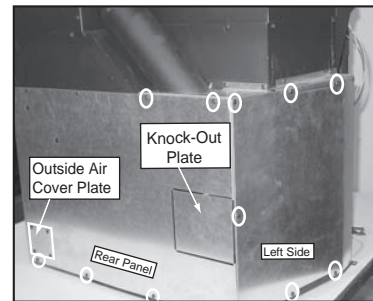

Figure 19.3

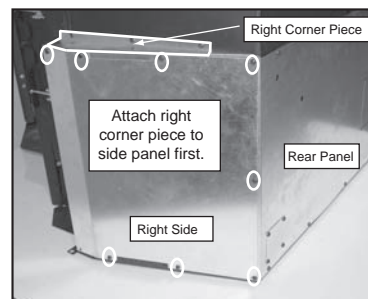

Figure 19.4

Attaching Shroud to Hopper Body:

6. Beginning at the right shroud panel drill into hopper body through the 3 pre-drilled openings and the 2 pre-drilled openings on the rear shroud panel. **Figure 19.5.** Continue around to left shroud corner panel at the 2 pre-drilled openings. **Figure 19.6.** Secure with screws to insert.
7. **For Top Vent Installation:** Install 3 inch or 4 inch (76 or 102mm) top vent adapter. See circled area in **Figure 18.3 on page 18.** NOTE: This adapter may be attached to outside venting prior to latching it on to the top vent pipe.

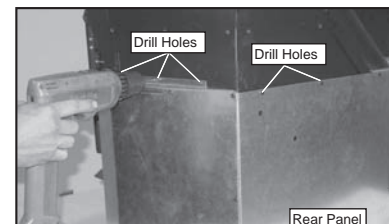

Figure 19.5



Figure 19.6

B. Outside Air Kit Instructions

Parts Included in Kit: 1 piece of 2 inch x 3 ft. flex hose, 1 hose clamp and 1 rodent screen.

Tools Needed: Phillips head screw driver; wire cutters; hole saw or jig saw.

1. Measure distance from floor to air vent opening in appliance and mark location on wall.
2. Use saw to cut opening in wall. Cut a 2-1/2 to 3 inches (64-76mm) opening on inside wall and a 3 to 3-1/2 inch (76-89mm) opening on outside of house.
3. Use hose clamp to secure flex pipe to collar assembly.
4. Slide trim ring over flex pipe and run pipe through wall.
5. Attach hose to outside termination cap with second hose clamp.
6. Secure termination cap to outside surface.
7. Secure trim ring to interior wall.

CAUTION
Never draw outside combustion air from: <ul style="list-style-type: none"> • Wall, floor or ceiling cavity • Enclosed space such as an attic or garage

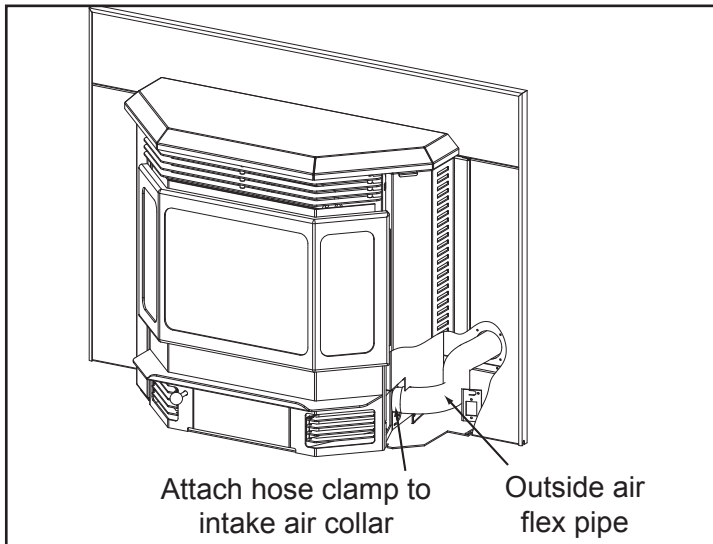

Figure 20.1

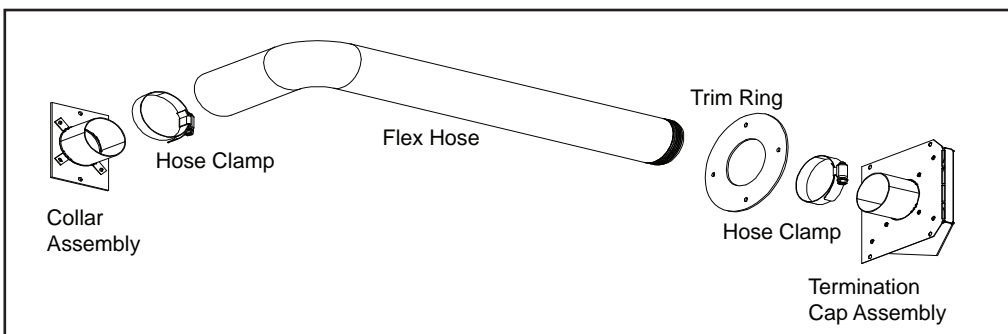

Figure 20.2

C. Adjustable Hopper Options

Depending on your installation, the hopper can be vertically adjusted up to a maximum of 3-1/2 inches (89mm) and will hold an additional 15 lbs of fuel.

To adjust hopper:

1. Using a Phillips head screw drive, remove all the screws from the top of the hopper securing the top hopper piece to the bottom hopper piece and insert body.
2. Adjust upward a maximum of 3-1/2 inches (89mm).
3. Mark location for new holes and drill new holes.
4. Secure hopper pieces together using screws removed in step one.
5. See drawing on **page 8, Figure 8.3.**

D. Grille Installation

1. Remove grille from packaging.
2. Lift top up.
3. Align the 3 holes in the insert with the holes in the grille.
4. Use a Phillips screw driver to secure in place. It will be necessary to go through the hole in the bag support shelf to gain access to the screw. **Figure 20.3.**
5. Lower the top into position.

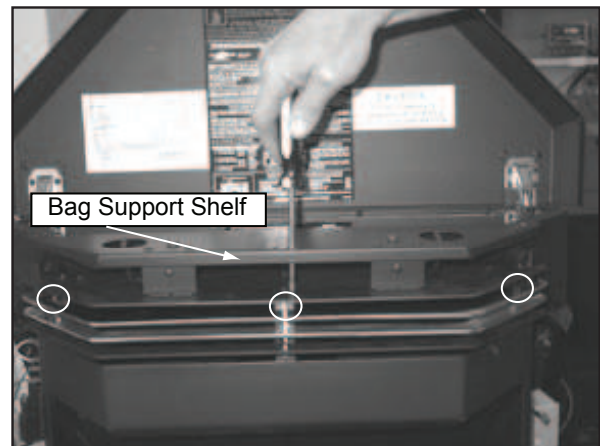

Figure 20.3

E. Adjustable Hearth Support

Size: 9"D x 45"W, 2" to 10" Height Adjustment

Included in Kit: (1) trim top, (1) trim front, (2) trim sides, double-sided tape (already installed)

Tools Needed: Phillips head screw driver, sheet metal shears, measuring tape, gloves

1. The 10 screws on each set of scissors will already be loose when shipped. **Figure 21.1.**
2. Expand scissors to desired height. Tighten screws to hold in place using Phillips head screw driver. **Figure 21.2.**
3. Measure front and side trims to required height to cover scissors and mark pieces for cutting. Cut excess material from **top** of trim's edge, not bottom. This edge will be sharp; wear gloves to prevent injury to your hands. **Figure 21.3.**
4. Using sheet metal shears, cut trim along the marked edge. The cut edge fits under lip of top trim, so it allows for some variance in your straight edge.
5. The double-sided tape that holds front and side trims to scissors has a powerful bonding adhesive. Adjustments are extremely difficult once trim has adhered to tape. Do a dry run first without removing paper from tape.
6. Place cut edge of trim under top lip and into position on scissors. Place side pieces on first and then front piece. The front piece overlaps side pieces.
7. Once you are satisfied with the positioning, remove trim and set aside.
8. Remove the paper from double-sided tape that is to accept trim side. Align side and then press hard against tape to secure side piece. Repeat for other side. Install front trim piece last.
9. There are 3 holes in the back flange of the top to secure it to the wall if necessary. Use the appropriate fastener for the type of wall material, i.e., brick, sheetrock, etc.

NOTE: 3/8 inch (9.5mm) thick tile or like material can be cut to size and fit under lip of top trim edge for a decorative touch. **Figure 21.3.**

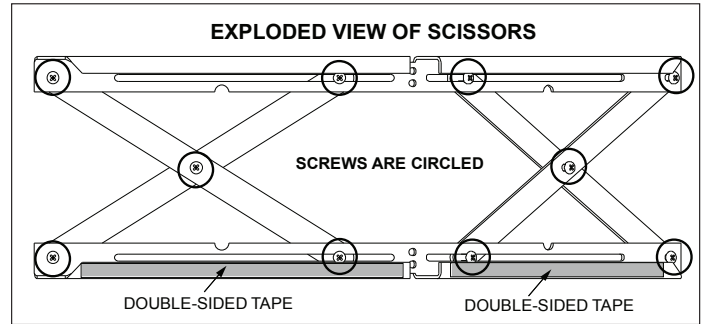

Figure 21.1

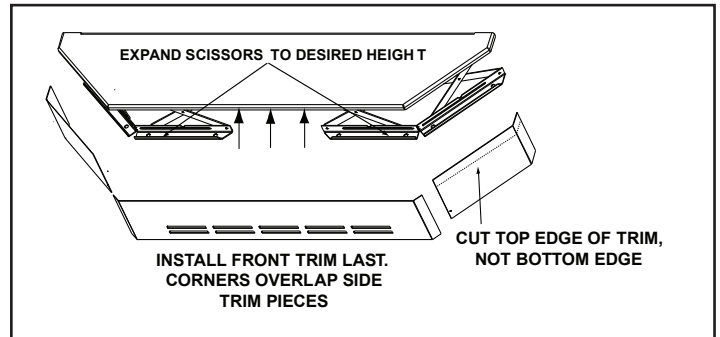

Figure 21.2

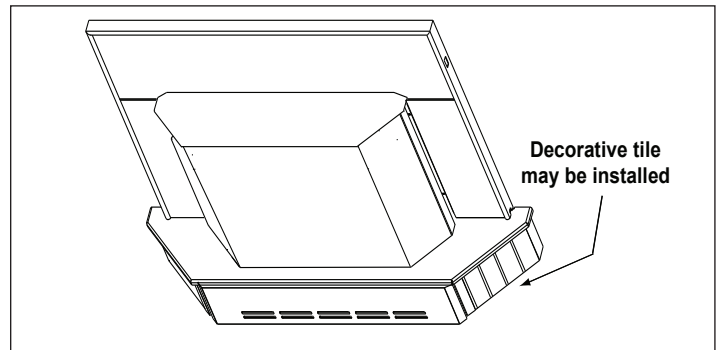

Figure 21.3

	<p>WARNING</p>
<p>Sheet metal trim edges will be sharp. For safety purposes wear gloves. Injury can occur.</p>	

F. Panel and Trim Set

Standard Size: 30 inches H x 40 inches W (762mm x 1016mm)

Large Size: 33 inches H x 50 inches W (838mm x 1270mm)

Included in Kit: 2 side panels, 1 top panel, 2 side trim, 1 top trim, 2 corner brackets and fastener package.

Tools Needed: Phillips and flat head screw drivers.

1. Unpack and lay out parts face down (flanges up) on a non-abrasive surface as shown in **Figure 22.1**. Install (1) 8-32 x 3/8 inch screw into bottom tab of side panel.
2. Set the large hole at bottom of side curtain over screw installed in **Figure 22.3**.
3. Stand assembly on end and attach and install (1) 8-32 x 3/8 inch screw through tab in side panel and curtain. **Figure 22.4**. Lay face down as shown in **Figure 22.5**.
4. Align top panel to side panel setting clearance hole over screw head in side panel/curtain assembly. Install (2) 8-32 x 3/8 inch screws through holes in side panel into top panel. **Figure 22.6**. Complete for both sides.



Figure 22.3

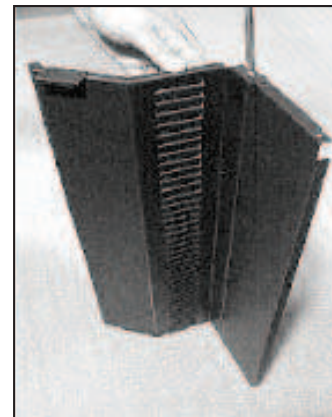

Figure 22.4

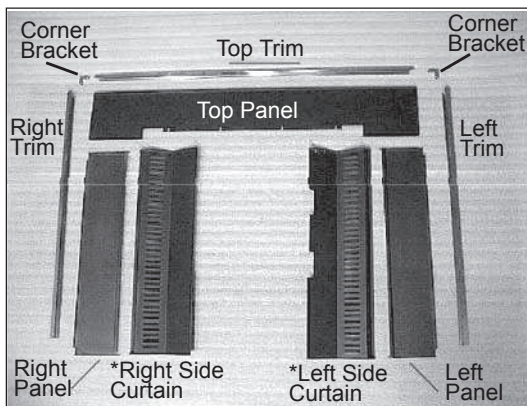

Figure 22.1

NOTE: *Right and left side curtains are shipped with the insert.

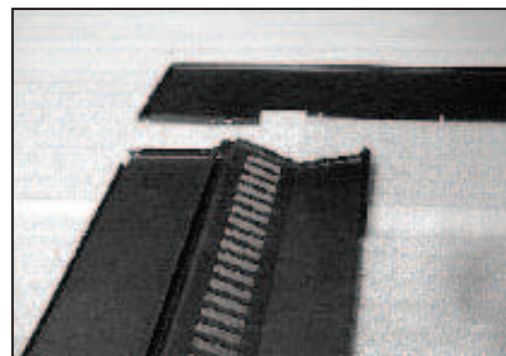

Figure 22.5

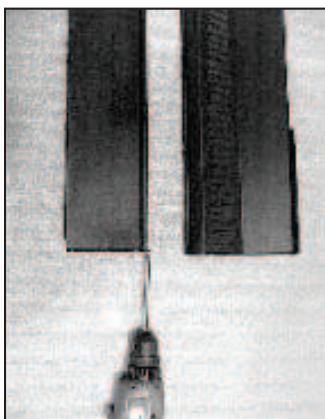

Figure 22.2



Figure 22.6

F. Panel and Trim Set (Cont'd)

5. Hold side curtains in open position and lower panel set over insert setting lower edge of top panel in slot between hopper lid and panel support as shown in **Figure 23.1**. Place existing screw head (installed in **Figure 23.2**) into locator hole in floor of insert. **Figure 23.2**.
6. Lift hopper lid and press down on panel top while installing (4) 8-32 x 3/8 inch screws into holes in panel support. (If screws have been factory installed, tighten to secure panel to panel support.) Return hopper lid to closed position.
7. Install a corner bracket on each side trim piece. Slide brackets into top trim from each side and secure with flathead screwdriver. Attach trim assembly to panel set as follows:
 - a. Ensure that brackets face towards the back.
 - b. Align trim assembly to panel set sides and slide down.

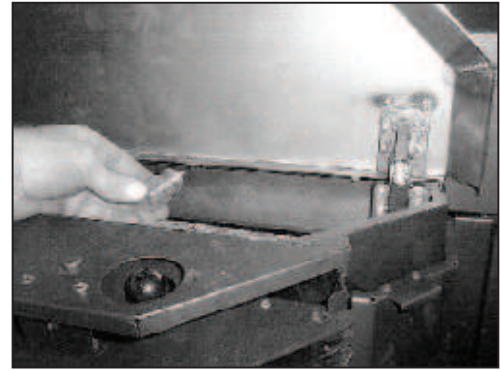

Figure 23.3



Figure 23.1

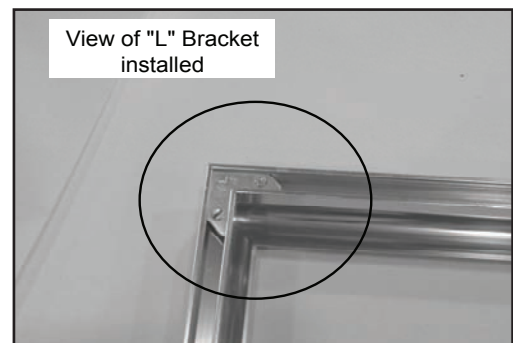

Figure 23.4

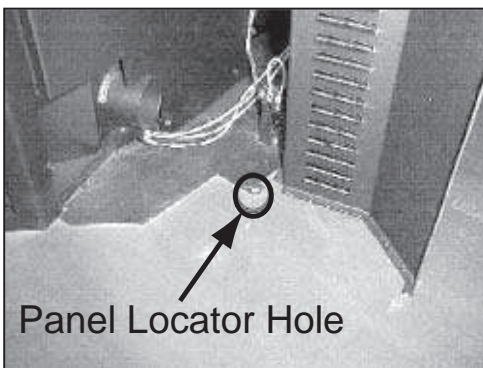

Figure 23.2



Figure 23.5- Completed View

G. Optional Brick Set Installation

1. Slide bottom of left rear brick in first; rotate top edge toward rear of appliance and then rotate outer edge toward rear of appliance, until brick slides into place. **Figure 24.1.** Repeat for right rear brick.
2. Place left side brick along left side of firebox, making sure chamfered (beveled) back edge fits snugly next to left rear brick. **Figure 24.2.** Repeat with right side brick.
3. Complete brick set, correctly installed. **Figure 24.4.**

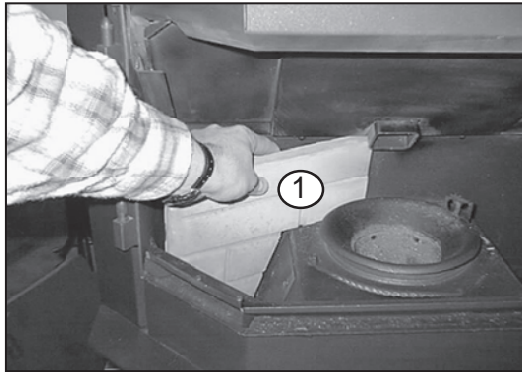

Figure 24.1

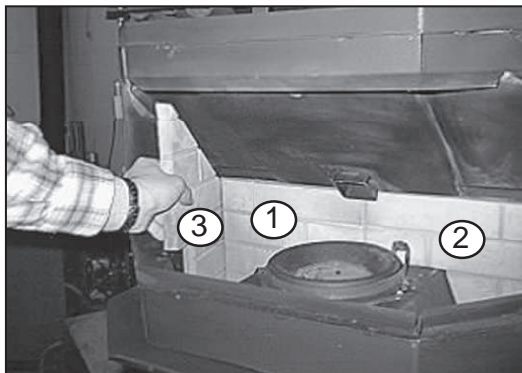

Figure 24.2

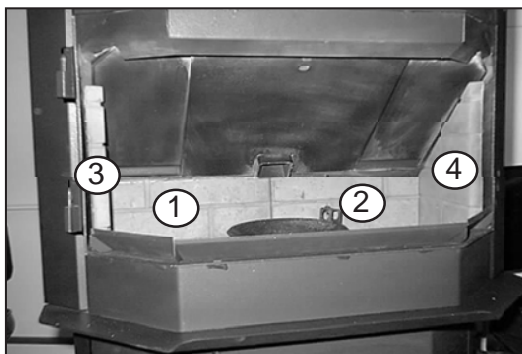

Figure 24.3

WARNING

Risk of Injury.

- Brick may have small wires protruding from the back of brick.

H. Brick Clip Installation

1. After the brick set has been installed, 2 brick clips need to be installed on the outer edge of baffle to keep the brick set in place. Remove the baffles from the appliance before installing the brick clips.
2. Using pliers, bend the brick clip slightly past 90° in the direction shown in **Figure 24.4.**
3. Position the brick clip as shown in **Figure 24.4** and use pliers to crimp around the outside edge of the baffle. **Figure 24.5** shows the finished shape of the brick clip after being bent around the outside edge of the baffle.
4. Slide the baffles back into place making sure that the brick clip holds the brick out toward the wall of the firebox. Push back on the sides so they keep the rear bricks in place. Repeat for the opposite side.

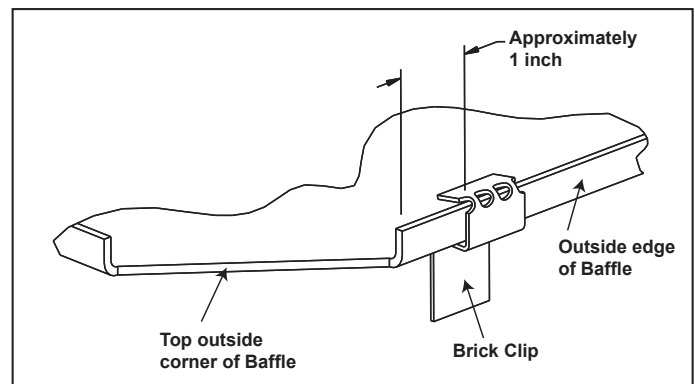

Figure 24.4

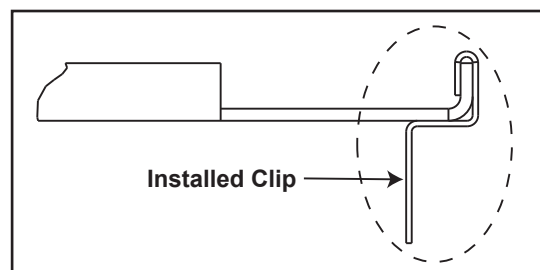

Figure 24.5

I. Optional Log Set Placement Instructions

CAUTION

Logs are FRAGILE. Use extreme care when handling or cleaning logs.

1. Place the front log in first as shown in **Figure 25.1** charred area surrounding firepot.
2. Set the left and right logs onto the front log, placing the holes in the base of the left and right logs over the locating pins in the front log. See **Figure 25.2**. Ensure that the charred ends are facing the firepot.

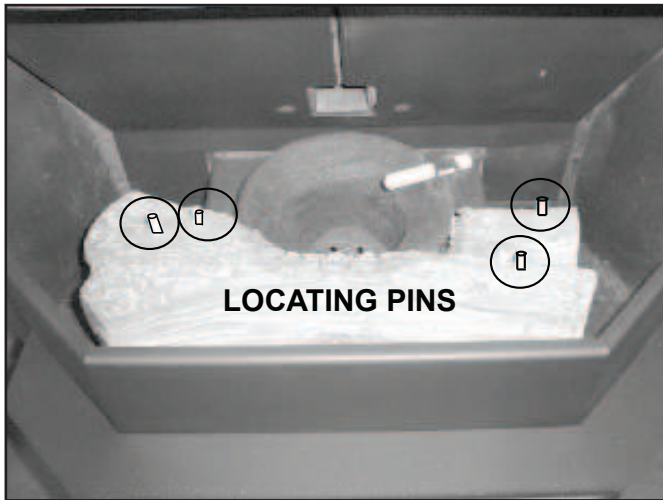

Figure 25.1

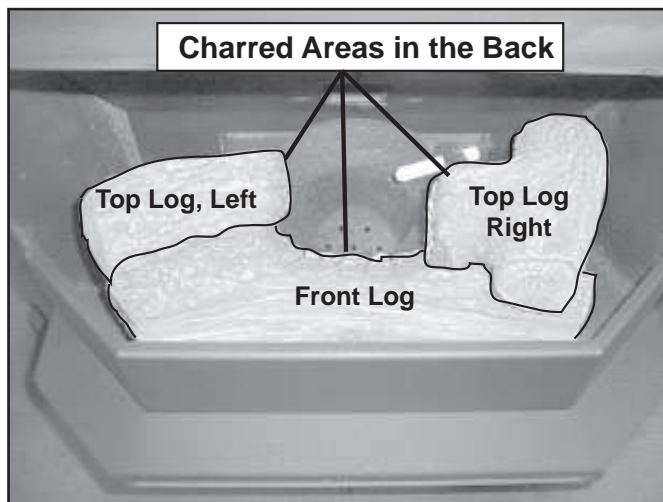

Figure 25.2

NOTE:

Due to the abrasive nature of a pellet appliance fire, the logs are not covered under warranty. Any placement variation other than shown here can cause excessive heat and shall void the appliance warranty.

J. Thermostat Installation

1. A 12 volt AC thermostat is required to operate this pellet appliance. You may use the included wall mount thermostat or purchase an optional programmable thermostat or remote control. The included thermostat is equipped with an adjustable heat anticipator. The current rating is .05 amps. The anticipator needs to be adjusted to the lowest setting available.
2. When mounting a thermostat on a wall, be sure to follow your thermostat installation instructions carefully.

NOTE: Thermostat must be mounted level for accurate readings. The thermostat should be mounted on an inside wall and not in direct line with the appliance convection air. Remove any packaging from inside the thermostat before using.

NOTE: If the thermostat is located too close to the appliance, you may need to set the temperature setting slightly higher to maintain the desired temperature in your home.

3. Open right side plane to access a 4 screw terminal block located on the bottom right hand side next to the power cord inlet. The center 2 screws are for the thermostat wires. The outer 2 are the mounting screws for the terminal block. **Figure 25.3**.

CAUTION

Shock hazard.

- Do NOT remove grounding prong from plug.
- Plug directly into properly grounded 3 prong receptacle.
- Route cord away from appliance.
- Do NOT route cord under or in front of appliance.

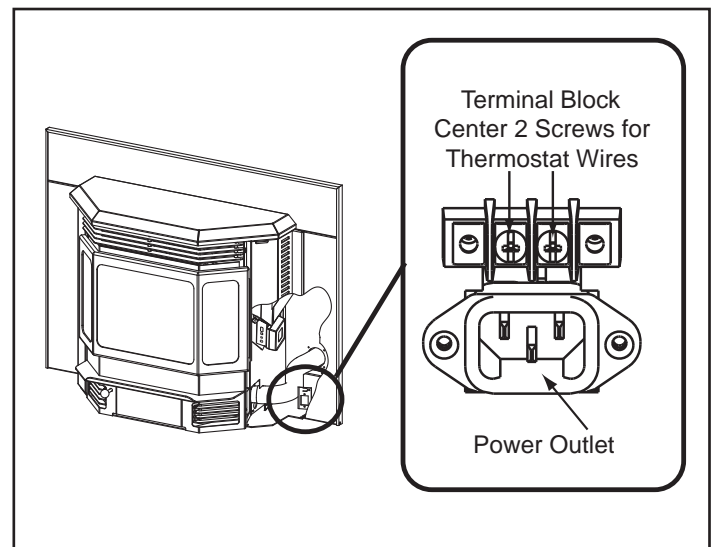

Figure 25.3

8 Operating Instructions

A. Fuel Size, Material and Storage



1. Wood Pellets

Fuel pellets are made from sawdust or wood by-products. If the source material is hardwood, they can have a higher mineral content, creating more ash. Fuels containing bark will also have higher ash content. Minerals and other noncombustible materials such as sand will turn into a hard, glass-like substance called a clinker when heated to the extreme temperatures our firepot reaches. This is what forms clinkers in the bottom of the firepot. Trees from different areas will vary in mineral content. That is why some fuels produce more clinkers than others. Pellets are manufactured in either 1/4 inch or 5/16 inch (6-8mm) diameter and should be **no more than 1-1/2 inches (38mm) in length**. Pellet lengths may even vary by lot from the same manufacturer which is why the feed rate may need to be adjusted occasionally. **If you burn pellets longer than 1-1/2 inches (38mm) you may have an inconsistent fuel feed rate and/or missed ignitions.**

Pellet fuel quality can greatly fluctuate. We recommend using premium grade fuel with ash content less than 1%. Even in some fuel labeled "premium" ash content can vary from bag to bag and possibly exceed 1%. High ash fuel, or lack of maintenance, can cause the firepot to fill up and thus create a potential for smoking, sooting and possible hopper fires.

Always burn dry fuel. Burning fuel with high moisture content takes heat from the fuel and tends to cool the appliance, robbing heat from your home. Damp pellet fuel can clog the feed system.

We recommend that you buy fuel in multi-ton lots whenever possible. Buying large quantities of fuel at once will greatly reduce the number of times the feed adjustments will need to be made. However, we do recommend trying various brands before purchasing multi-ton lots to ensure your satisfaction.

	WARNING
	<p>Fire Risk.</p> <ul style="list-style-type: none"> High ash fuels, or lack of maintenance, can cause the firepot to overflow. Follow proper shutdown procedure if ash buildup exceeds half way point in firepot. Failure to do so could result in smoking, sooting and possible hopper fires.

2. Shelled Field Corn

Extensive factory and field testing has demonstrated shelled field corn to be an efficient and very economical fuel. We recommend the use of a 50-50 blend of corn and wood pellets. The only change in operation is that the feed rate may require a slight adjustment. The BTU output of the appliance varies slightly compared to pellets, depending on the quality of the

2. Shelled Field Corn (Cont'd)



corn used. In cases where it is acceptable for the appliance to run full time, 100% corn will work after the fire has been started using wood pellets.

When purchasing corn to burn in your appliance, read the ingredient label very carefully. **Do NOT purchase fuel that contains any additives** such as oils (i.e. soybean oil) and meals as it will result in poor unit performance. If you are buying corn the only ingredient that should be listed is corn.

Shelled field corn must be 15% or less moisture content. The corn must be clean and free from debris. Never burn corn straight from the field. Stalk parts, excessive fines and cob remnants, etc. will clog the auger mechanism. Corn with excessive grain dust must be screened by sifting with 3/16 (4.76mm) inch mesh screening.

Do not burn treated seed corn in your appliance. Seed corn is treated with chemical pesticides that are harmful or fatal if swallowed; therefore, seed corn is dangerous to have in the house, especially where children can reach it. Burning treated seed corn in your appliance will void your warranty and will destroy the exhaust system on the unit.

When changing to a different fuel, be sure to empty the hopper of the previous fuel and vacuum the hopper before you fill it with the new fuel.

	WARNING
	<p>Risk of Chemical Poisoning.</p> <ul style="list-style-type: none"> Do <u>Not</u> burn treated seed corn Chemical pesticides are harmful or fatal if swallowed Burning treated seed corn will void your warranty

3. Storage

Wood pellets should be left in their original sealed bag until using. This will prevent moisture absorption.

Shelled corn should be stored in a tight container where it will not absorb moisture from damp or wet floors. This will also prevent rodents from becoming a problem.

Do not store any pellet fuel within the clearance requirements or in an area that would hinder routine cleaning and maintenance.

B. General Operating Information

1. Thermostat Calls For Heat

The appliance is like most modern furnaces; when the thermostat calls for heat, your appliance will automatically light and deliver heat. When the room is up to temperature and the thermostat is satisfied, the red call light will shut off and the appliance will shut down. **Figure 27.1.**

2. Heat Output Controls

This appliance is equipped with a heat output control switch that has three settings or burn rates; low, medium and high. The appliance will turn on and off as the thermostat demands. When the thermostat calls for heat, the appliance will always start up on High. After burning approximately 4 minutes, the appliance will then burn at the rate at which it was originally set. If the appliance is set at one of the lower settings, it will run quieter but takes longer to heat up an area than if it were set at a higher burn rate. Regardless of the burn rate, when the area is warm enough to satisfy the thermostat, the appliance will shut off.

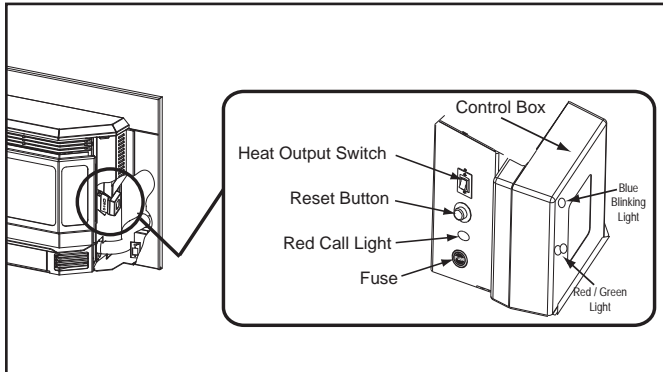

Figure 27.1

C. Before Your First Fire

1. First, make sure your appliance has been properly installed and that all safety requirements have been met. Pay particular attention to the fire protection, venting and thermostat installation instructions.
2. Double check that the ash pan and firebox are empty!
3. Check the position of the thermocouple, located above the firepot, and make sure that it protrudes approximately 3/4 inch (19mm) into the firepot.
4. Close the front door.

CAUTION
Tip of thermocouple must be in contact with the inside end of the thermocouple cover.
Missed ignitions can occur.

D. Starting Your First Fire

1. A thermostat is required for proper operation of this appliance, except for corn. At this time, fill the hopper with pellets, set the thermostat to its lowest setting. Plug the power cord into nearby outlet.
2. The exhaust blower will stay on for approximately 10 minutes even though the thermostat is not calling for heat. This is normal.
3. Locate the heat output control switch on the right side behind the right side panel. Set to the HIGH setting and then adjust the thermostat to its highest setting. The red call light will be on which is located on the right side behind the right side panel. This indicates the thermostat is calling for heat. **Figure 27.1.**
4. The fuel feed system and the igniter should now be on.
5. For your first fire it will be necessary to press the reset button approximately 2 minutes after start-up and again at 4 minutes. This will fill the feed system and allow the appliance to begin dropping pellets. Continue pushing the reset button until you detect that pellets are being delivered into the firepot. The appliance will continue to run as long as the thermostat is calling for heat.
6. Once the appliance has ignited, let the it burn for approximately 15 minutes, then set the thermostat to the desired room temperature. Adjust the heat output control switch to the desired setting.

CAUTION
Odors and vapors released during initial operation. <ul style="list-style-type: none"> • Curing of high temperature paint. • Open windows for air circulation. Odors may be irritating to sensitive individuals.

WARNING
<div style="display: flex; align-items: center;"> <div> <p>Fire Hazard. Keep combustible materials, gasoline and other flammable vapors and liquids clear of appliance.</p> <ul style="list-style-type: none"> • Do NOT store flammable materials in the appliance's vicinity. • DO NOT USE GASOLINE, LANTERN FUEL, KEROSENE, CHARCOAL LIGHTER FLUID OR SIMILAR LIQUIDS TO START OR "FRESHEN UP" A FIRE IN THIS HEATER. • DO NOT BURN GARBAGE OR FLAMMABLE FLUIDS SUCH AS GASOLINE, NAPHTHA OR ENGINE OIL. • DO NOT USE CHEMICALS OF FLUIDS TO START THE FIRE. • Keep all such liquids well away from the heater while it is in use. • Combustible materials may ignite. </div> </div>

E. Fire Characteristics

A properly adjusted fire with the heat output control switch set on "HIGH" has a short active flame pattern that extends out of the firepot approximately 4 to 6 inches (102-105mm). If the fire has tall flames with black tails and seems somewhat lazy, the feed rate will need to be reduced. If the fire is not 4 inches to 6 inches (102-105mm) tall, increase the feed rate. A medium and low setting will give a shorter flame. The flame will rise and fall somewhat. This is normal.

F. Feed Rate Adjustment Instructions

The feed adjustment control rod is factory set, and should be adequate for most fuels. The set screw is located at the bottom of the hopper and *set loose at the factory* so the fuel adjustment control rod will slide by only loosening the wing nut. Do not re-tighten bottom set screw.

However, if the flame height is too high or too low, you will need to adjust the feed rate. Wait until the appliance has been burning for 15 minutes before making your adjustments and allow 15 minutes for feed adjustment to take effect.

1. Open the hopper lid and locate the fuel adjustment control rod.
2. Loosen the wing nut on the rod.
3. Adjust the fuel adjustment control rod towards the "+" symbol to increase the feed rate and flame height or towards the "-" symbol, to decrease the feed rate and flame height. Make approximately 1/2 inch (13mm) movements of rod at a time.
4. Re-tighten the wing nut.

G. Ignition Cycles

1. During each ignition cycle, it is normal to see some smoke in the firebox. The smoke will stop once the fire starts.
2. The convection blower will automatically turn on after your appliance has reached the set temperature. This blower transfers heat from your appliance into the room, and will continue to run after the thermostat has stopped calling for heat until the appliance has cooled down.
3. Occasionally the appliance may run out of fuel and shut itself down. When this happens, the red call light will be on. To restart it, fill the hopper and press the reset button. When you press the reset button the red call light will go out. Release the button and the light will come back on. You should see a fire shortly. If not, follow the instructions "Starting Your First Fire". on this page.

WARNING



Fire Risk

Do NOT operate appliance:

- With appliance door open.
- Firepot floor open.
- Cleaning slide plates open.

Do NOT store fuel:

- Closer than required clearances to combustibles to appliance
- Within space required for loading or ash removal.

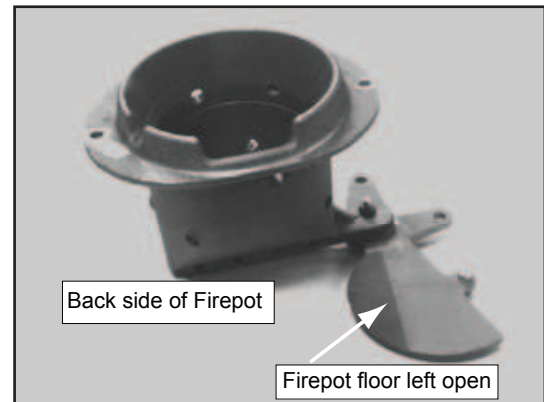

Figure 28.1 - DO NOT LEAVE FIREPOT FLOOR OPEN

H. Frequently Asked Questions

ISSUES	SOLUTIONS
1. Metallic noise.	1. Noise is caused by metal expanding and contracting as it heats up and cools down, similar to the sound produced by a furnace or heating duct. This noise does not affect the operation or longevity of your appliance.
2. Ash buildup on glass.	2. This is normal. Clean the glass.
3. Glass has turned dirty.	3. Excessive build up of ash. The lower burn settings will produce more ash, the higher burn settings produce less. The more it burns on low the more frequent cleaning of the glass is required.
4. Fire has tall flames with black tails and is lazy.	4. The feed rate needs to be reduced or the firepot needs cleaning. Heat exchanger or exhaust blower needs cleaning.
5. Smokey start-up or puffs of smoke from the airwash.	5. Either the firepot is dirty or there is too much fuel at start-up and not enough air. Close down feed rate 1/4 inch (6mm) at a time until this no longer happens.
6. Large flame at start-up.	6. This is normal. Flame will settle down once the fire is established.

CAUTION

Odors and vapors released during initial operation.

- Curing of high temperature paint.
- Open windows for air circulation.

Odors may be irritating to sensitive individuals.

9 Troubleshooting

With proper installation, operation, and maintenance your appliance will provide years of trouble-free service. If you do experience a problem, this troubleshooting guide will assist a qualified service person in the diagnosis of a problem and the corrective action to be taken. ***This troubleshooting guide can only be used by a qualified service technician.***

Symptom	Possible Cause	Corrective Action
Plug in appliance - No response.	No current to outlet. .7 amp fuse defective. #3 snap disc tripped or defective. Control box defective.	Check circuit breaker at service panel. Replace fuse. Reset or replace snap disc. Replace control box.
Call light on. No fire. No fuel in firepot.	Out of fuel. #2 snap disc may be defective. Vacuum switch not closing, no vacuum. Control box defective.	Check hopper. Fill with fuel. Replace snap disc. Check exhaust blower is plugged in and operating. Check vacuum switch is plugged in. Check vacuum hose is in good condition, clear and connected at both ends. Check thermocouple is in good condition and plugged in properly. Make sure venting system is clean. Make sure front door is closed. Replace control box.
Call light on. No fire. Partially burned fuel in firepot.	Firepot clean-out plate not closed. Firepot is dirty (missed ignition).	Check that firepot clean-out plate is fully closed. Clean firepot. Make sure there is no clinker in the firepot. Clinkers may have to be broken up with firepot scraper tool or other means.
Call light on. No fire. Unburned pellets in firepot.	Firepot clean-out plate not closed. Firepot is dirty. Ignition hole blocked. Igniter not working. Control box defective.	Check that firepot clean-out plate is fully closed. Clean firepot. Make sure there is not a clinker in the firepot. Clinkers may have to be pushed out of firepot with firepot scraper tool or other means. Scrape with solid piece of wire. Remove ash pan to see if igniter is glowing red on start-up. Check igniter wires for good connection. Replace igniter using 1/4 inch male /female spade connectors. Replace control box.
Slow or smoky start-up.	Firepot clean-out plate not closed. Firepot is dirty. Excessive amount of fuel at start-up.	Check that firepot clean-out is fully closed. Clean firepot. Make sure there is not a clinker in the firepot. Clinkers may have to be pushed out of firepot with firepot scraper tool or other means. Reduce feed rate using feed rate adjustment control rod located inside hopper.

Troubleshooting (Cont'd)

Symptom	Possible Cause	Corrective Action
Slow or smoky start-up (Cont'd)	Dirty exhaust and/or venting system.	Check for ash build up in appliance, including behind rear panels, firebox, heat exchanger, exhaust blower and venting.
Feed system fails to start.	<p>Out of fuel.</p> <p>#2 snap disc may be defective.</p> <p>Vacuum switch not closing. No vacuum.</p> <p>Feed system jammed or blocked.</p> <p>Feed spring not turning with feed motor.</p> <p>Feed motor defective or not plugged in.</p>	<p>Check hopper, fill with fuel.</p> <p>Replace snap disc. Firebox door must be closed securely.</p> <p>Check exhaust blower is plugged in and operating.</p> <p>Check vacuum switch is plugged in.</p> <p>Check vacuum hose is in good condition, clear and connected at both ends.</p> <p>Check thermocouple is in good condition and plugged in properly.</p> <p>Make sure venting system is clean.</p> <p>NOTE: High winds blowing into the venting system can pressurize the firebox causing loss of vacuum.</p> <p>Empty hopper of fuel. Use a wet/dry vacuum cleaner to remove remaining fuel, from hopper, including feed tube.</p> <p>Check feed chute for obstructions.</p> <p>Loosen 2 screws and jiggle feed assembly.</p> <p>Check that set screw is tight on feed spring shaft at end of feed motor.</p> <p>Check connections on feed motor, replace if defective.</p>
No call light. Appliance does not begin start sequence.	<p>Thermostat not set to a high enough temperature.</p> <p>Snap Disc #3 tripped.</p> <p>No power.</p> <p>Fuse blown.</p> <p>Connections at thermostat and/or appliance not making proper contact.</p> <p>Defective thermostat or thermostat wiring.</p> <p>Control box defective.</p>	<p>Adjust thermostat above room temperature.</p> <p>Reset snap disc.</p> <p>Connect to power.</p> <p>Replace fuse.</p> <p>Check connections at thermostat and appliance.</p> <p>Replace thermostat or wiring.</p> <p>NOTE: To test thermostat and wiring, use a jumper wire at the thermostat block on the appliance to by-pass thermostat and wiring.</p> <p>Replace control box.</p>
Appliance fails to shut off.	Call light on.	<p>Turn thermostat off.</p> <p>If call light does not go out, disconnect thermostat wires from appliance. If call light does go out, thermostat or wires are defective.</p>

Troubleshooting (Cont'd)

Symptom	Possible Cause	Corrective Action
Convection blower fails to start.	No call light. #1 snap disc defective. Blower not plugged in. Blower is defective. Control box is defective.	Defective control box. Replace snap disc. Check that blower is plugged into wire harness. Replace blower. Replace control box.
Exhaust blower fails to start or does not shut off.	Blower not plugged in. Blower is clogged with ash. Blower is defective. Control box is defective.	Check that blower is plugged into wire harness. Clean exhaust system. Replace blower. Replace control box.
Large, lazy flame, orange color. Black ash on glass.	Dirty appliance. Poor fuel quality, high ash content. Firepot clean-out plate not completely closed. Excessive amount of fuel.	Clean appliance, including firepot, heat exchangers and venting system. Remove stainless steel baffle from firebox to clean ash from on top of baffle. Clean behind rear brick panels. Change fuel brand to premium. Check that firepot clean-out plate is fully closed. Reduce feed rate using feed rate adjustment control rod located inside hopper.
Nuisance shutdowns.	Low flame. Sawdust buildup in hopper. Feed motor is reversing. Defective thermocouple. Defective control box. Firepot more than 1/2 full	Increase feed by opening feed rate adjustment control rod located inside hopper. Clean hopper, see page 34 . Check for good connections between feed motor and wire harness. Replace thermocouple. Replace control box. See page 37 for detailed instructions for "High Ash Fuel Content Maintenance".
Appliance calls for heat. Call light illuminates. Exhaust blower starts. No feed or igniter.	Thermocouple is defective or not properly plugged in. Defective control box	Check connections on thermocouple or replace if defective. A flashing yellow light on the control box indicates a problem with the thermocouple. Replace control box.

10 Maintaining & Servicing Your Appliance

A. Proper Shutdown Procedure

CAUTION

Shock and Smoke Hazard

- Turn down thermostat, let appliance completely cool and exhaust blower must be off. Now you can unplug appliance before servicing.
- Smoke spillage into room can occur if appliance is not cool before unplugging.
- Risk of shock if appliance not unplugged before servicing appliance.

Follow the detailed instructions found in this section for each step listed as referenced in the chart below.

B. Quick Reference Maintenance Chart

Cleaning or Inspection	Frequency		Daily	Weekly	Monthly	Yearly
Ash Pan	Every 5 bags of fuel	OR		X		
Ash Removal from Firebox	More frequently depending on the fuel type or ash build-up	OR		X		
Beneath Heat Exchanger	Every 1 ton of fuel	OR			X	
Blower, Combustion (Exhaust)	More frequently depending on the fuel type	OR				X
Blower, Convection	More frequently depending on the fuel type	OR				X
Door Latch Inspection	Prior to heating season	OR			X	
Exhaust Path	More frequently depending on ash build-up	OR				X
Firebox - Prepare for Non-Burn Season	At end of heating season	OR				X
Firepot - Burning pellets - hardwood	Every 3 bags	OR	X			
Firepot - Burning pellets - softwood	Every 5 bags	OR	X			
Firepot - Burning Corn	Every 1 bag	OR	X			
Glass	When clear view of firepot becomes obscure	OR		X		
Heat Exchanger & Drop Tube	Every 1 ton of fuel	OR			X	
Hopper	Every 1 ton of fuel or when changing fuel types	OR			X	
Top Vent Adapter	More frequently depending on the fuel type or ash build-up	OR				X
Venting System	More frequently depending on the fuel type	OR				X

C. General Maintenance

1. Types of Fuel

Depending on the type of fuel you are burning will dictate how often you have to clean your firepot.

If the fuel you are burning has a high dirt or ash content or you are burning shelled field corn, it may be necessary to clean the firepot more than once a day.

Dirty fuel will cause clinkers to form in the firepot. A clinker is formed when dirt, ash or a non-burnable substance is heated to 2000°F (1093°C) and becomes glass-like. See “D” page 37 in this section for more details on fuels with high ash content.

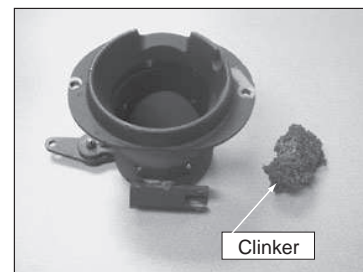

Figure 33.1 - Clinker

NOTICE: These are recommendations. Clean more frequently if you encounter heavy build-up of ash at the recommended interval or you see soot coming from the vent. **Not properly cleaning your appliance on a regular basis will void your warranty.**

2. Cleaning Firepot with Cleaning Rod & Firepot Clean-Out Tool

- **Frequency:** Daily or more often as needed
 - **By:** Homeowner
- a. Be sure the appliance is allowed to cool, has been unplugged and the exhaust blower is off. If you are just cleaning the firepot, there is no need to unplug the appliance.
 - b. Pull firepot cleaning rod OUT and IN a couple of times to help shake debris loose. If rod is hard to pull, it may be necessary to use your firepot clean-out tool to chip away material that has built up on the bottom plate of the firepot and to push out any clinkers. Larger clinkers may have to be removed from the top of the firepot. Corn clinkers can be especially difficult to break up.
 - c. The firepot floor plate must be fully closed when finished. **See Figure 27.1 on page 27.**

4. Cleaning Ash Pan

- **Frequency:** Weekly or every 5 bags of fuel
- **By:** Homeowner

Locate the ash pan underneath the firepot and using a slight pull up and out remove the ash pan. Empty into a non-combustible container and re-install ash pan. **See Disposal of Ashes.**

5. Disposal of Ashes

- **Frequency:** As needed
- **By:** Homeowner

Ashes should be placed in a metal container with a tight-fitting lid. The closed container of ashes should be placed on a non-combustible floor or on the ground, well away from all combustible materials, pending final disposal.

If the ashes are disposed of by burial in soil or otherwise locally dispersed, they should be retained in the closed container until all cinders have been thoroughly cooled.

	WARNING
	<p>Fire Risk.</p> <ul style="list-style-type: none"> • NEVER pull firepot cleaning rods or cleaning slide plates when appliance is operating. • Hot pellets may fall into ashpan and may start a fire or have mis-starts due to lack of vacuum.

3. Ash Removal from Firebox

- **Frequency:** Weekly or more frequently depending on ash build-up.
- **By:** Homeowner

	WARNING
	<p>Disposal of Ashes</p> <ul style="list-style-type: none"> • Ashes should be placed in metal container with tight fitting lid. • Ashes should be retained in closed container until all cinders have thoroughly cooled.

- a. There must not be any hot ashes in the firebox during cleaning so allow the appliance to completely cool. The firebox ash should be removed every time the firepot is cleaned. Frequent cleaning of the ash in the firebox will help slow down the build-up of ash in the exhaust blower and vent system.
- b. Plug in your appliance, if unplugged, and turn the thermostat on and immediately shut it off to start the exhaust blower on its cycle time. It will pull fly ash out the exhaust instead of into the room.
- c. Open cast hinged face. Directly underneath the firebox door and to the left and right of the firepot are 2 cleaning slide plates with finger holes. Pull both slide plates out and then open the glass door. Sweep the remaining ash from the firebox into the 2 open holes. A paint brush works well for this. Close slide plates.
- d. This ash is deposited in the same ash pan as the firepot debris. The ash pan should be emptied every time you clean the firebox. Remember to place the ash and debris into a metal or noncombustible container.
- e. The 2 cleaning slide plates must be fully closed when cleaning is complete. **See Disposal of Ashes.**

6. Cleaning the Hopper

- **Frequency:** Monthly or after burning 1 ton of fuel
- **By:** Homeowner

After burning approximately 1 ton of fuel or changing fuels you will need to clean the hopper to prevent sawdust build-up.

A combination of sawdust and pellets on the auger reduces the amount of fuel supply to the firepot. This can result in nuisance shutdowns and mis-starts.

- a. Be sure the appliance is allowed to cool, has been unplugged and the exhaust blower is off.
- b. Empty the hopper of any remaining pellets.
- c. Vacuum the hopper and feed tube.



WARNING



Heat exchanger cleaning rods may be warm to the touch. For safety purposes wear gloves.

Do not pull heat exchanger cleaning rods while appliance is operating.

Push cleaning rods IN when done, DO NOT leave cleaning rods OUT. Injury can occur.

7. Cleaning Heat Exchanger Chambers & Drop Tube

- **Frequency:** Weekly or every 1 ton of fuel
- **By:** Homeowner

The amount of ash buildup in the firepot will be a good guide to determine how often you should clean the heat exchangers.

- a. Allow the appliance to completely cool down before pulling the cleaning rods. Turn the thermostat on and then immediately off to start the exhaust blower on its cycle time. It will pull fly ash out the exhaust instead of into the room.
- b. To access the cleaning rods lift the hopper lid. Both black bent handle pull rods are located close to the face of the appliance to the left and right side.
- c. To clean, pull the rods straight out until it stops, approximately 20 inches (508mm). Slide the rods OUT and IN a couple of times.

8. Cleaning Beneath Heat Exchanger

- **Frequency:** Monthly or after burning 1 ton of fuel
 - **By:** Homeowner
- a. Be sure the appliance is allowed to cool, has been unplugged and the exhaust blower is off
 - b. A more thorough cleaning is needed to remove the excess ash that is left behind from the use of the cleaning rods for the heat exchanger tubes.
 - c. The ash will be resting on the back of the baffles. This will require removing the baffles. Please refer to **page 37** for instructions on removing the baffles.

9. Cleaning Exhaust Path

- **Frequency:** Yearly or more frequently depending on ash build-up.
- **By:** Homeowner
 - a. Be sure the appliance is allowed to cool, has been unplugged and the exhaust blower is off
 - b. Open the hinged access door on the left of the insert.
 - c. Reach in and unlatch the trap door that is connected to the rear of exhaust blower.
 - d. Use a small vacuum hose attachment to clean area.
 - e. Re-latch and close trap door.

NOTE: There are heavy duty vacuum cleaners specifically designed for solid fuel appliance cleaning.

10. Cleaning the Glass

- **Frequency:** When clear view of the firepot becomes obscure.
- **By:** Homeowner
 - a. Be sure the appliance is allowed to cool, has been unplugged and the exhaust blower is off.
 - b. Use a damp paper towel or any nonabrasive glass cleaner. Wipe off with dry towel.

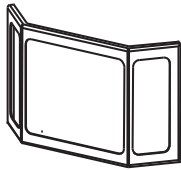

CAUTION

Handle glass assembly with care.

When cleaning glass:

- Avoid striking, scratching or slamming glass.
- Do NOT clean glass when it is hot.
- Do NOT use abrasive cleaners.
- Use a hard water deposit glass cleaner on white film.
- Refer to maintenance instructions.

11. Door Latch Inspection

- **Frequency:** Prior to heating season
- **By:** Homeowner
 - a. Be sure the appliance is allowed to cool, has been unplugged and the exhaust blower is off
 - b. To adjust, open the latch and pivot the holding rod out. Loosen the jam nut on the rod.
 - c. With a Phillips head screw driver, turn the rod clockwise to tighten. The latch handle should snap securely in place when adjusted properly.
 - d. After adjusting the latch, be sure to tighten the jam nut on the rod to hold the adjustment.

12. Door Gasket Inspection

- **Frequency:** Prior to heating season
- **By:** Homeowner
 - a. Be sure the appliance is allowed to cool, has been unplugged and the exhaust blower is off
 - b. To inspect the door rope (gasket), open the door and see that the door rope extends approximately 1/8 inch (3mm) to 3/16 inch (9.5mm) from the door rope channel.
 - c. It should show signs of compaction all the way around the door where the rope contacts the face of the appliance. Confirm there are no air leaks.

13. Cleaning Exhaust Blower - Requires No Lubrication

- **Frequency:** Yearly or as needed
- **By:** Quality Service Technician/Homeowner
- **Task::** **Contact your local dealer.**

14. Cleaning Convection Blower - Requires No Lubrication

- **Frequency:** Yearly or as needed
- **By:** Qualified Service Technician
- **Task:** **Contact your local dealer.**

15. Soot and Fly Ash: Formation & Need for Removal in Exhaust Venting System.

- **Frequency:** Yearly or more frequently depending on ash build-up.
- **By:** Qualified Service Technician/Homeowner

Be sure the appliance is allowed to cool, has been unplugged and the exhaust blower is off.

The products of combustion will contain small particles of fly ash. The fly ash will collect in the exhaust venting system and restrict the flow of the flue gases.

At start-up if there is incomplete combustion, or if there is a shutdown or incorrect operation of the appliance it will lead to some soot formation. This will collect in the exhaust venting system.

The venting system may need to be cleaned at least once a year or more often depending upon the quality of your fuel or if there is a lot of horizontal pipe sections. Ash will build up more quickly in the horizontal sections.

16. Preparing Firebox for Non-Burn Season

- **Frequency:** Yearly
- **By:** Homeowner
 - a. Be sure the appliance is allowed to cool, has been unplugged and the exhaust blower is off.
 - b. Remove all ash from the firebox and vacuum thoroughly.
 - c. Paint all exposed steel, including cast-iron.
 - Use the Touch-Up paint supplied with the appliance; or,
 - Purchase paint from your local dealer.
 - Must use a high-temperature paint made specifically for heating appliances.

D. High Ash Fuel Content Maintenance

- **Frequency:** When the ash build-up exceeds more than half way up the firepot.
- **By:** Homeowner

Poor quality pellet fuel, or lack of maintenance, can create conditions that make the firepot fill quickly with ashes and clinkers.

This condition makes the appliance susceptible to overflowing the firepot with pellets which may result in smoking, sooting and possible hopper fires. **Figure 35.1** shows an example where the firepot overfills, pellets back up into the feed tube and ash has accumulated in the firebox.

An inefficient and non-economical method of burning of fuel caused by poor quality pellet fuel is shown in **Figure 37.2**.

The correct flame size when good quality, premium pellet fuel is burned is shown in **Figure 37.3**.

If the ash buildup exceeds the half way point in the firepot **IMMEDIATE ATTENTION AND CLEANING IS REQUIRED.**

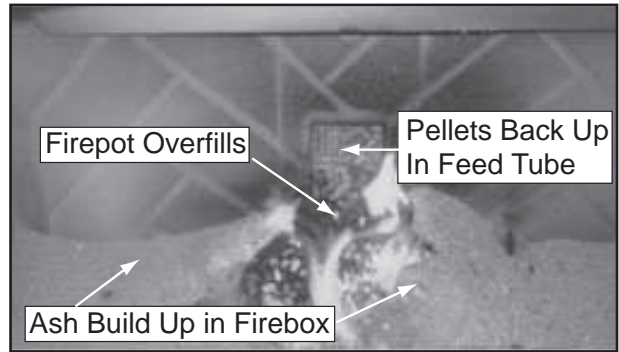

Figure 37.1

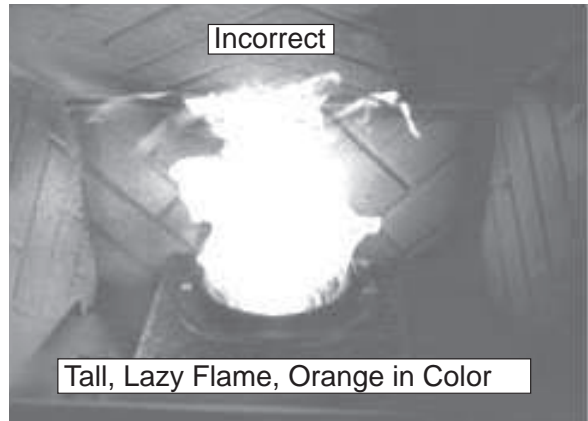

Figure 37.2

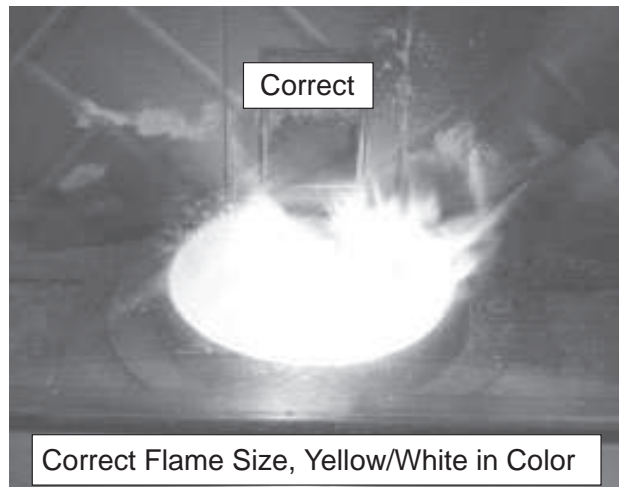



Figure 37.3

	<p>WARNING</p>
	<p>Fire Risk.</p> <ul style="list-style-type: none"> • High ash fuels, or lack of maintenance, can cause the firepot to overflow. Follow proper shutdown procedure if ash buildup exceeds half way point in firepot. • Failure to do so could result in smoking, sooting and possible hopper fires.

E. Glass Replacement

⚠ WARNING	
	<ul style="list-style-type: none"> • Glass is 5mm thick high temperature heat-resistant ceramic glass. • DO NOT REPLACE with any other material. • Alternate material may shatter and cause injury

- Remove door from appliance and place face down on a protected surface to avoid scratching the door.
- Remove all door rope.

1. Replacing Center Glass

NOTE: DO NOT LET Air Wash Spacers fall down from top frame when removing and replacing center glass.

- Be sure the appliance is allowed to cool, has been unplugged and the exhaust blower is off.
- Using a nut driver remove the (5) bottom nuts and remove the bottom glass frame. **Figure 36.2.**
- Slightly bend up and out of the way the 2 center posts and slide the glass out the bottom.
- Slide new glass in, reposition the 2 center posts and re-install bottom glass frame.
- Re-rope the door.

2. Replacing Side Glass

NOTE: When removing the side glass with the door latch, you must remove the door latch first before removing the side frame. Use a powered Phillips head screw driver to remove the 4 screws.

- Be sure the appliance is allowed to cool, has been unplugged and the exhaust blower is off.
- Remove side glass frame.
- Loosen the top and bottom frame and slightly bend up and out of the way.
- Slide glass out the side and slide new glass in.
- Re-install the side glass frame and tighten the top and bottom frames.
- Re-install the door latch, if applicable, and re-rope the door.

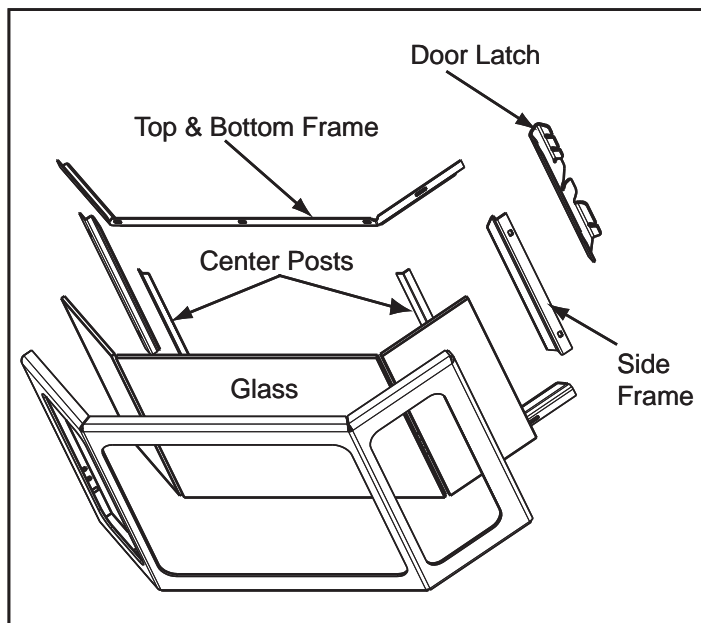

Figure 38.1

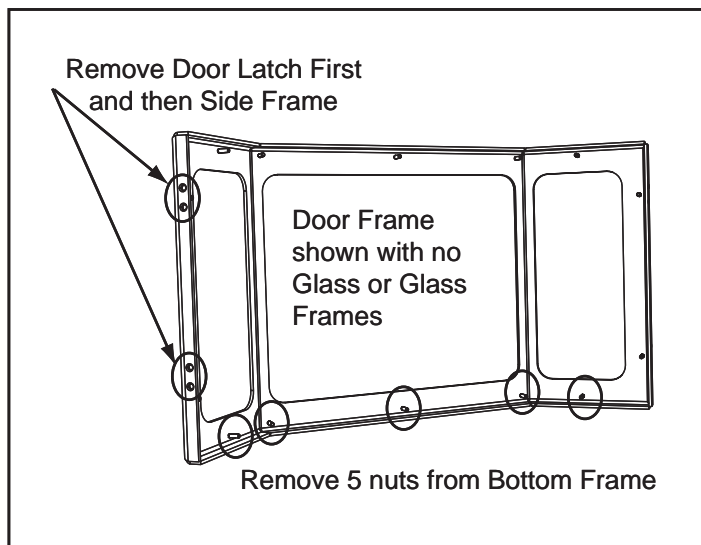
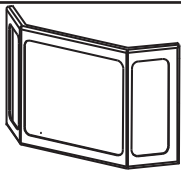

Figure 38.2

⚠ WARNING	
	<p>Handle glass with care.</p> <ul style="list-style-type: none"> • Inspect the gasket to ensure it is undamaged. • Do NOT strike, slam or scratch glass. • Do NOT operate appliance with glass assembly removed. <p>Do NOT operate with glass cracked, broken or scratched.</p>

F. Igniter Replacement

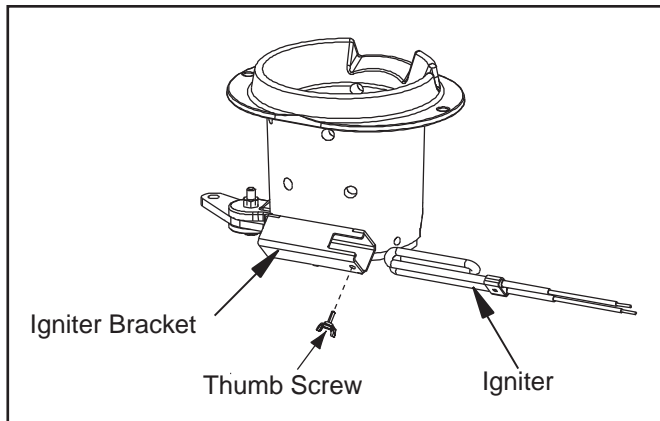

Figure 39.1

G. Baffle Removal

- a. Be sure the appliance is allowed to cool, has been unplugged and the exhaust blower is off.
- b. Open glass door.
- c. Grasp the bottom of the baffles and pull up to dislodge from hook attachment.
- d. Use a standard screw driver to unlatch the covers beneath the baffles of each side.
- e. Re-install in reverse order.

- a. Be sure the appliance is allowed to cool, has been unplugged and the exhaust blower is off. Remove the ash pan.
- b. The wire leads to the igniter are connected to the wire harness with 1/4 inch male / female spade connectors. These wires will pull forward approximately 4 to 5 inches (102mm to 127mm). Disconnect the spade connections and remove the igniter from the chamber. Loosen the thumb screw and slide igniter out.
- c. Install new igniter into the chamber and tighten the thumb screw. Re-connect the wires to the 2 leads with the spade connectors.
- d. Push excess wire leads to take-up the 4 to 5 inches (102mm to 107mm) previously pulled out. This will keep the wires out of the way of the ash pan. Double check that the igniter wires are clear of any movement, i.e. ash pan, firepot cleaning rod, etc.
- f. Re-install the ash pan and re-connect the power.

11

Reference Materials



When describing the location of a component part it is always **AS YOU FACE THE FRONT OF THE APPLIANCE**.

A. Component Function

1. Control Box

- The control box is located on right side of appliance, behind the right side panel.
- There is a light located inside of the control box. The internal light will turn green when the appliance has reached a temperature of 200°F (93°C) in the firepot. and will turn red when it reaches 600°F (315°C).
- There is also an internal blue light located in the upper left corner of the control box. When you plug in the appliance the blue light will automatically start blinking 1 blink every 10 seconds for 60 seconds and then will stop.

NOTE:

Do **NOT** open the control box. This will void the warranty. If you need to plug in or remove the control box you must first **unplug the appliance**.

2. Convection Blower

The convection blower is mounted at the bottom rear of the appliance. There are 2 impellers, one on each side of the motor. The convection blower pushes heated air through the heat exchange system into the room.

3. Combustion (Exhaust) Blower

The combustion blower is mounted on the left side of the appliance behind the left side panel. It is accessible either when the insert is pulled out onto the hearth or from both hinged side openings. The blower is designed to pull the exhaust from the appliance and push it out through the venting system.

4. Feed System

The feed system is located behind the firebox and can be removed as an entire assembly. The assembly includes the feed motor, mounting bracket, bearing and feed spring (auger). The hollow feed spring (auger) pulls pellets up the feed tube from the hopper area and drops them down the feed chute into the firepot.

5. Firepot

The firepot is made of high quality ductile iron and has a cleaning pull-out rod. The floor of the firepot opens for cleaning when you pull out the rod. Be sure that the floor returns to a completely closed position or your appliance will not operate properly.

6. Fuse

The fuse is located on the right side of the appliance behind the side panel. The fuse will blow should a short occur and shut off power to the appliance.

7. Heat Exchangers

The heat exchangers transfer heat from the exhaust system into convection air. There are 2 clean out rods located under the heat exchangers.

8. Heat Output Switch

The heat output switch is located on the right side of firebox, behind right side panel. The function of the heat output switch is to regulate the burn rates; low, medium and high settings.

9. Igniter

The igniter is mounted on the base of the firepot. Combustion air travels over the red hot igniter creating super heated air that ignites the pellets.

10. Junction Box And Wiring Harness

The junction box is located on the right side of the appliance, behind the right front access panel. The junction box and wiring harness are replaced as one component.

11. Power Supply

The power outlet is located on the right side of the appliance. Check the wall receptacle for 120 volt, 60 Hz (standard current). Make sure the outlet is grounded and has the correct polarity. A good surge protector is recommended. When operating with a generator you need at least 600 watts of power, or with an inverter at least 800 watts of power, available for the appliance during the start cycle.

12. Red Call Light

The red call light is on the right side behind the right side panel. The function of the red call light is to indicate that the thermostat is calling for heat.

13. Reset Button

The reset button is located on the right side of firebox behind right side panel. The function of the reset button is to momentarily open the thermostat circuit, which restarts the system.

14. Thermocouple

The thermocouple is located on top of the firepot inside the thermocouple cover (ceramic protection tube). The thermocouple sends a millivolt signal to the control box indicating the preset temperatures of the green and red lights have been obtained.

15. Thermostat

The appliance is designed to run on a 12 volt AC thermostat. The heat anticipator, if present, should be set on the lowest setting available.

16. Snap Disc #1 (Convection Blower) 125°F

Snap disc #1 is located on the right side of the firebox. There are 2 purple wires connected to it. This snap disc turns the convection blower on and off as needed. Power is always present at snap disc #1.

17. Snap Disc #2 (Fuel Delivery Interrupt) 200°F

Snap disc #2 is located on the back side of the feed drop tube. There is 1 orange wire and 1 black wire connected to it. This snap disc will turn off the feed system, which will turn off the appliance if an overfire condition should occur or if the convection blower should fail to operate. If this occurs the snap disc will automatically reset itself.

18. Snap Disc #3 (Burn Back Protector) 250°F

Snap disc #3 is mounted on the right side of the auger tube just below feed motor and has a reset button. To access it remove the right side panel. If the fire tries to burn back into the feed system or push exhaust up the feed tube, this snap disc will shut the entire system off. This disc must be manually reset.

19. Vacuum Switch

The vacuum switch is located at the rear of the appliance. This switch turns the feed system on when vacuum is present in the firebox. The vacuum switch is a safety device to shut off the feed motor if the exhaust or the heat exchanger system is dirty or plugged or if the firebox door is open.

20. Wiring Harness

See Figure 41.1 below

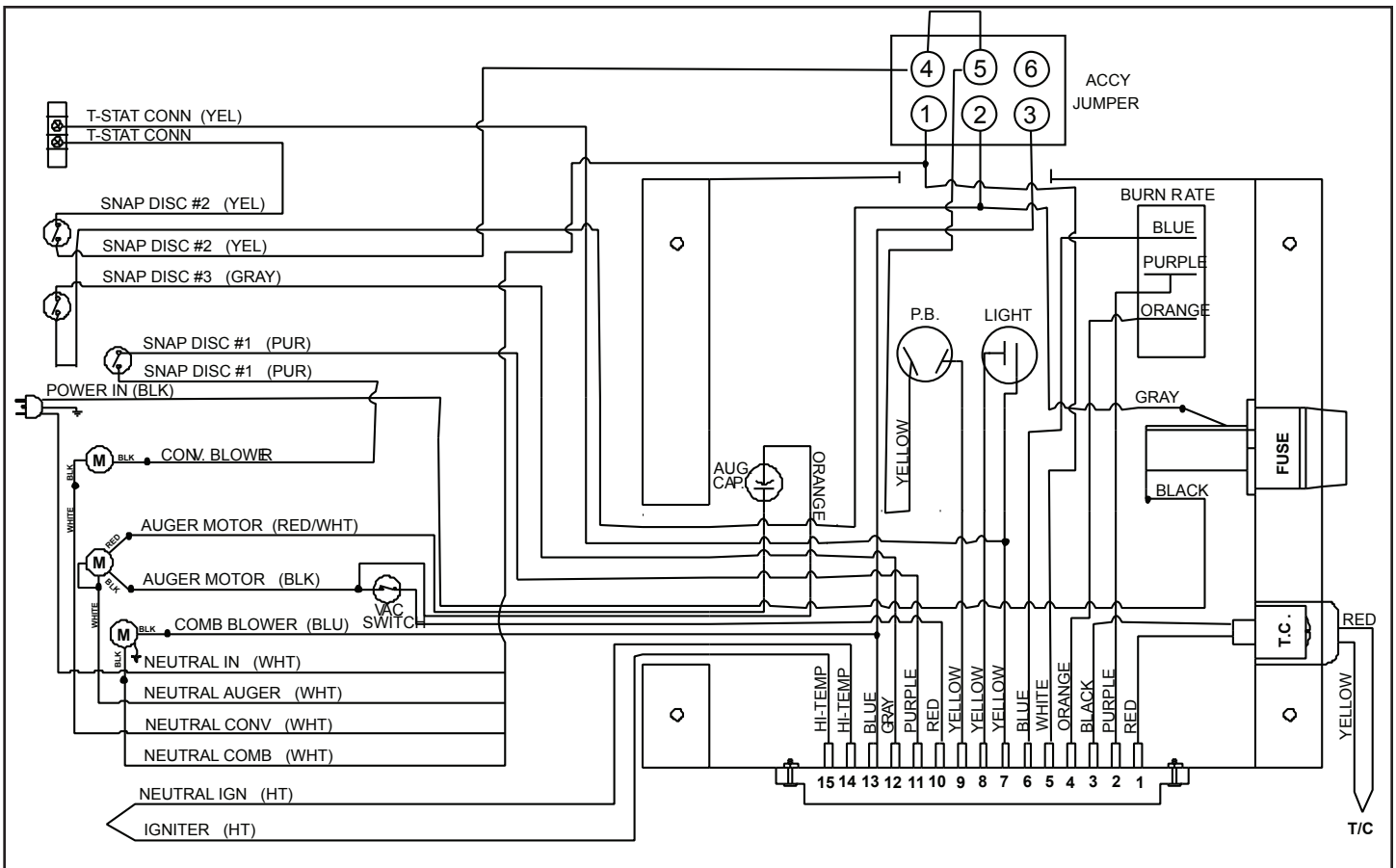

Figure 41.1

B. Component Locations

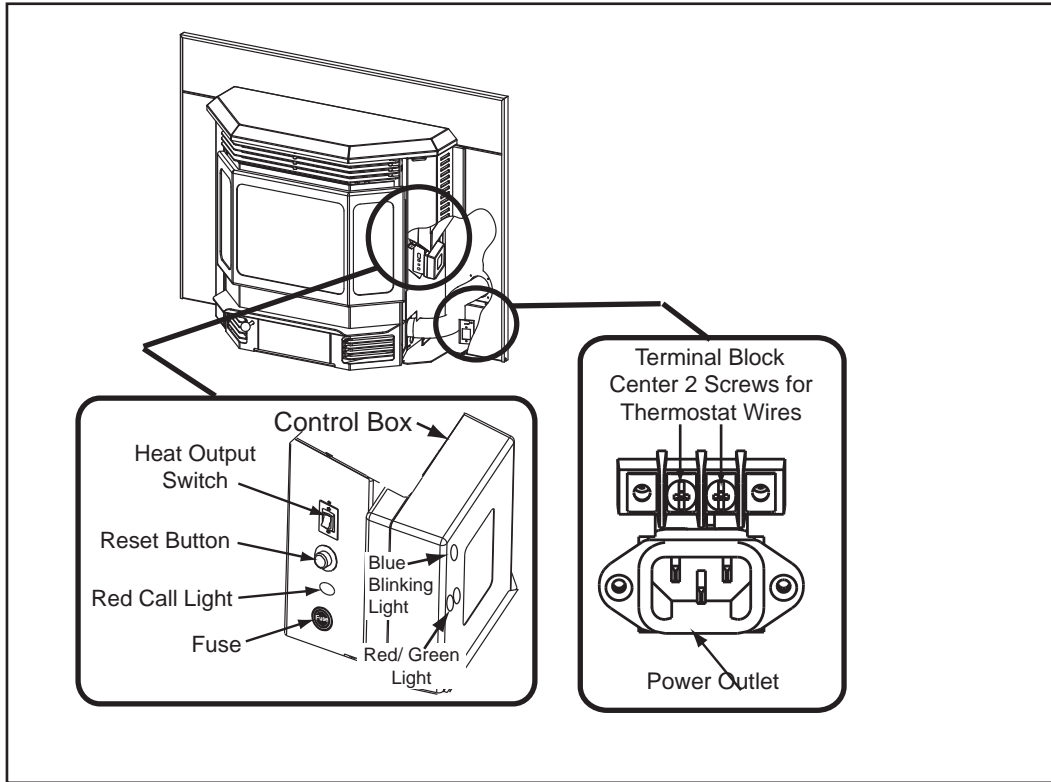

Figure 42.1

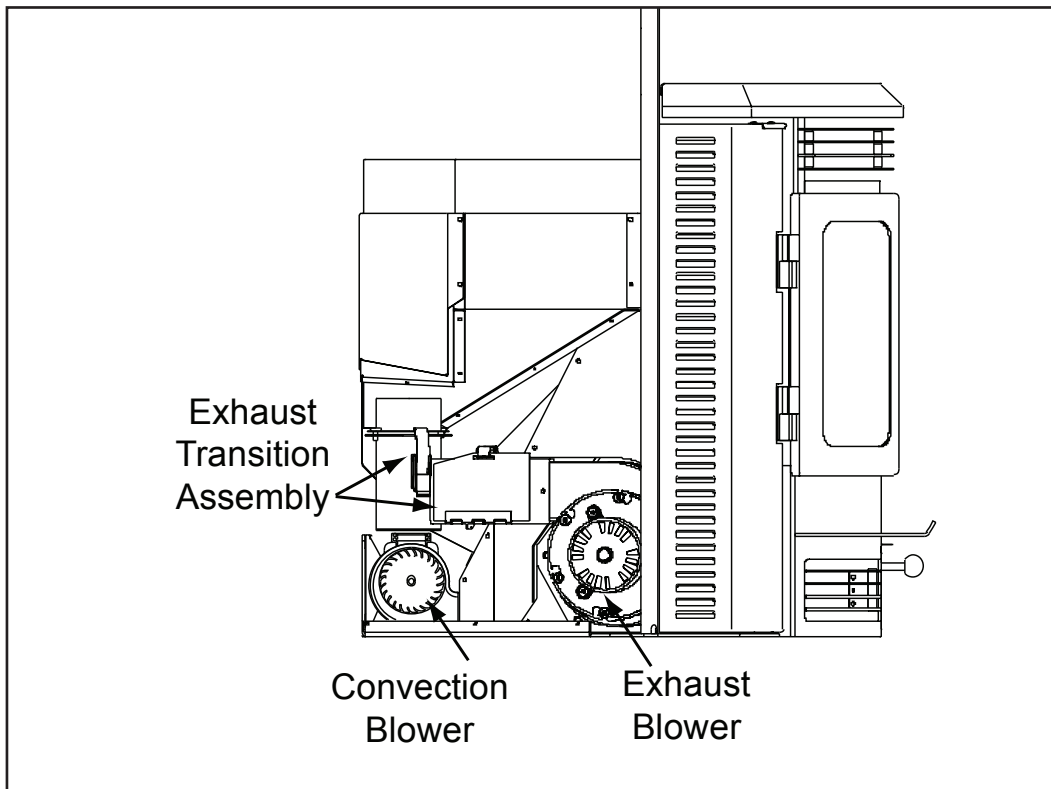
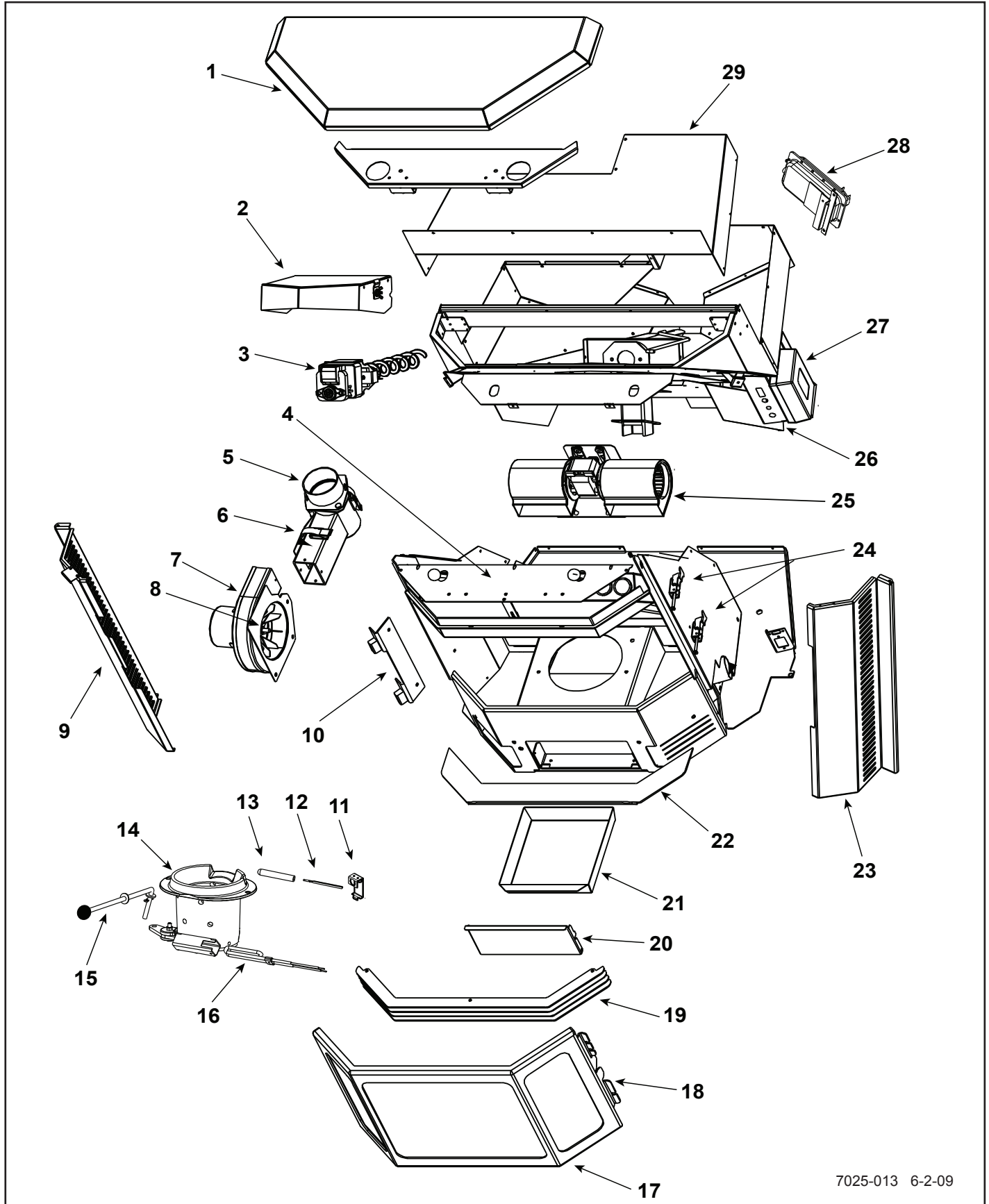

Figure 42.2

C. Exploded Drawing



7025-013 6-2-09

Figure 43.1

D. Service Parts and Accessories

IMPORTANT: THIS IS DATED INFORMATION

HOW TO ORDER

When requesting service or replacement parts for your appliance please provide model number and serial number. All parts listed may be orderd from an authorized dealer.

To order the entire assembly, order the top line part number only.
To order an individual part from an assembly, order the part(s) listed in the indented portion.



Item	Description	Comments	Part Number	Stocked at Depot
1	Top		SRV410-7960	
	Hinge, Hopper Lid		812-4220	
	Mount, Hopper Lid Support, Left		410-8200	
	Mount, Hopper Lid Support, Right		410-7410	
	Mount, Hopper Lid Support, Top		410-7560	
2	Cover, Feed Motor, Top		410-7920	
3	Feed Motor Assembly		812-3690	Y
	Collar, Set, 7/8		229-0520	
	Gasket, Feed Motor		240-0731	Y
	Bearing, Feed System, Nylon		410-0552	Y
	Mount, Feed Motor		410-7172	
	Feed Motor		812-4421	Y
	Capacitor, Rep Jumper		230-2150	Y
	Feed Spring Assembly		SRV7027-024	Y
	Snap Disc, Manual Reset		SRV230-1290	Y
4	Extension, Heat Shield, Top		410-7860	
5	Exhaust Adapter Assembly		510-5330	
	Gasket, Flue Adapter		240-0850	Y
6	Exhaust Transition Assembly		510-5340	
	Gasket, Top Vent		240-0840	
	Latch, Draw		229-0230	
7	Blower, Combustion/Exhaust		812-3381	Y
8	Gasket, Exhaust Combustion Blower	Between Housing & Stove	240-0812	Y
		Between Motor & Housing	812-4710	Y
9	Curtain, Side, Left		812-4310	
10	Mount, Door Hinge		410-7290	
11	Thermocouple Bracket W/Set Screw		812-3171	Y
12	Thermocouple		812-0210	Y
13	Thermocouple Cover	Qty: 1	812-1322	Y
		Qty: 10	812-4920	Y
14	Firepot Assembly		812-3351	Y
	Nut, Lock 1/4-20		226-0090	
	Bushing, Firepot		410-8320	
	Floor, Firepot		414-0290	
	Bolt, Firepot, 1-1/4" Long		225-0120	
	Gasket, Firepot		510-0530	Y

HOW TO ORDER

To order the entire assembly, order the top line part number only.
 To order an individual part from an assembly, order the part(s) listed in the indented portion.



Stocked at Depot

Item	Description	Comments	Part Number	Stocked at Depot
15	Rod/Linkage Ez Clean		812-4140	
	Knob, Ash Dump Control Rod		200-0831	
	Spring, Firepot		200-2050	
	Clip, Hitch Pin, #25		229-0360	
16	Heating Element Assembly 18" (Loop Igniter)	Qty: 1	SRV7000-462	Y
		Qty: 10	SRV7000-462/10	Y
17	Door Assembly	Black	DR-CB12-MBK-B	
		Gold	DR-CB12-GD-B	
		Nickel	DR-CB12-NL-B	
	Door Rope, 7/8", 8 Ft	Qty: 8 Ft, Field Cut to Size	842-2350	Y
	Gasket, Glass	Qty: 10 Ft, Field Cut to Size	833-0660	
	Glass Assembly, Center	13-7/8 in. W x 11 in. H	510-5400	Y
	Glass Assembly, Side, 1 Pc	5-1/8 in. W x 11 in. H, Qty: 1	510-5410	Y
	Glass Retainer Assembly		510-5460	
	Hinge, Female		450-2910	
18	Bracket, Door Latch		410-4912	
19	Grille, Louver	Black	LVGRL-CB12-BK-B	
		Gold	LVGRL-CB12-GD-B	
		Nickel	LVGRL-CB12-NL-B	
	Grille, Bar, Bottom		410-8330	
20	Panel, Front Access		812-4290	
21	Ash Pan		812-4130	
22	Ashcatcher		410-7830	
23	Curtain, Side, Right		812-4320	
24	Latch, Draw		229-0640	Y
25	Blower, Convection		812-4900	Y
26	Wire Harness / Junction Box		SRV7000-155	Y
	Block, Thermostat Term Dv		230-0690	
	Capacitor, Rep Jumper		230-2150	Y
	Igniter Extension		7000-218	
27	Control Board 3 Speed		SRV7000-205	Y
28	Vacuum Switch		SRV7000-447	Y
29	Hopper Top		410-7730	
	Baffle, Left		812-4200	Y
	Baffle, Right		812-4210	Y
	Bracket, Magnet Mount		410-7760	
	Bumper, Rubber	Qty: 12	SRV224-0340/12	
	Call Light Bulb		812-0760	Y

HOW TO ORDER

To order the entire assembly, order the top line part number only.
 To order an individual part from an assembly, order the part(s) listed in the indented portion.



Stocked at Depot

Item	Description	Comments	Part Number	Stocked at Depot
	Call Light Lens Cover		812-0750	Y
	Call Light, Fluorescent		SRV7000-122	
	Ceramic Nuts, (Igniter)	Qty: 1	812-0730	Y
		Qty: 12	812-0730/12	Y
	Component Pack (Includes Firepot Cleanout Tool, Power Cord, Wire Harness For Thermostat, Owners Manual, 'Caution Fireplace Altered' Label, Paint, Warranty Card, "How To" Dvd		812-4330	
	Cleanout Tool		414-1140	Y
	Dvd Original Energy Insert		7000-441	
	Harness, Thermostat Wire		230-0810	
	Paint Touch-Up		7000-304	
	Power Cord		812-1180	Y
	Door, Cleanout, Exhaust Plenum		410-7910	
	Feed Adjustment Assembly		510-5450	
	Thumbscrew, 1/4-20 X 3/4		844-5070	
	Fuse, 7 Amp, Junction Box	Qty: 1	812-0380	Y
		Qty: 10	812-0380/10	Y
	Fuse, 8 Amp, Control Box	Qty: 1	812-3780	Y
		Qty: 10	812-3780/10	Y
	Hinge, Door, Male		450-2810	
	Hose, Vacuum, 5/32 Id	Qty: 3 Ft, Field Cut to Size	SRV240-0450	Y
	Igniter Wire (5Ft) & (4) Ceramic Nuts		812-4520	Y
	Latch, Magnet		229-0631	
	Snap Disc, 200 Open/40 D, # 2		SRV230-0900	Y
	Snap Disc, # 1, Convection Blower		SRV230-0470	Y
	Snap Disc, Manual Reset		SRV230-1290	Y
	Thermocouple Grounding Kit		812-4980	
ACCESSORIES				
	Adjustable Hearth Support	12 in. X 50 in., 2-10 in. H	ADJSPT-12	
	Damper, 3 Inch	Tall Vertical Installs Only	PEL-DAMP3	
	Damper, 4 Inch	Tall Vertical Installs Only	PEL-DAMP4	
	Door Assembly	Black	DR-CB12-MBK-B	
		Gold	DR-CB12-GD-B	
		Nickel	DR-CB12-NL-B	
	Floor Protector		811-0730	

HOW TO ORDER

To order the entire assembly, order the top line part number only.
 To order an individual part from an assembly, order the part(s) listed in the indented portion.



Stocked at Depot

Item	Description	Comments	Part Number	Stocked at Depot
	Grille, Louver	Black	LVGRL-CB12-BK-B	
		Gold	LVGRL-CB12-GD-B	
		Nickel	LVGRL-CB12-NL-B	
	Log Set	Qty: 3	811-0592	
	Log, Front		7027-219	
	Log, Top Left		7027-221	
	Log, Top Right		7027-220	
	Outside Air Kit		811-0700	
	Hose, Alum Flex, 2 Inch X 3 Ft	Qty: 3 Ft	200-0860	
	Panel Set, Large, W/Gold Trim	33 in X 50 in.	SP-CB12I3350-GD	
	Bracket, -L-, Trim	Qty: 2	832-0840	
	Logo, Quadra-Fire		200-3180	
	Trim, Panel Set, Gold		250-4660	
	Panel Set, Large, W/Nickel Trim	33 in X 50 in.	SP-CB12I3350-NL	
	Bracket, -L-, Trim	Qty: 2	832-0840	
	Logo, Quadra-Fire		200-3240	
	Trim, Panel Set, Ots, Nickel		510-5220	
	Panel Set, Small, W/Gold Trim	30 in. X 40 in.	SP-CB12I3040-GD	
	Bracket, -L-, Trim	Qty: 2	832-0840	
	Logo, Quadra-Fire		200-3180	
	Trim, Panel Set, Std, Gold		811-0710	
	Panel Set, Small, W/Nickel Trim	30 in. X 40 in.	SP-CB12I3040-NL	
	Bracket, -L-, Trim	Qty: 2	832-0840	
	Logo, Quadra-Fire		200-3240	
	Trim, Panel Set, Std, Nickel		510-5210	
	Shroud, Rear		811-0680	
	Smart-Batt II		841-0970	
	Smart-Stat II		841-0960	
	Thermostat, Mechanical		812-3760	
	Thermostat, Programmable		811-0520	
	Top Vent Adapter, 3"		811-0660	
	Top Vent Adapter, 4"		811-0670	
	Top Vent Kit, Rear Shroud		811-0650	
	Vent Adapter, 3-4"		811-0720	
	Vent Kit, Rear		811-0690	

HOW TO ORDER

To order the entire assembly, order the top line part number only.
 To order an individual part from an assembly, order the part(s) listed in the indented portion.



Stocked at Depot

Item	Description	Comments	Part Number	Stocked at Depot
FASTENERS				
	Avk Rivnut Repair Kit	1/4-20 & 3/8-16 Rivnut Tools	RIVNUT-REPAIR	Y
	Nut, Keps Lock, 8-32	Qty: 40	226-0060/40	Y
	Nut, Ser Flange Small 1/4-20	Qty: 24	226-0130/24	Y
	Screw, Pan Head Philips 8-32 X 3/8	Qty: 40	225-0500/40	Y
	Screw, Pan Head Philips 10-32 X 3/8	Qty: 40	21799A/40	Y
	Screw, Sheet Metal #8 X 1/2 S-Grip	Qty: 40	12460/40	Y
	Screw, Machine Screw 1/4-20X5/8	Qty: 24	220-0440/24	Y
	Washer, 1/4 Sae	Qty: 24	28758/24	Y

**Hearth & Home Technologies Inc.
LIMITED LIFETIME WARRANTY**

F. Warranty Policy

Hearth & Home Technologies Inc., on behalf of its hearth brands ("HHT"), extends the following warranty for HHT gas, wood, pellet, coal and electric hearth appliances that are purchased from an HHT authorized dealer.

WARRANTY COVERAGE:

HHT warrants to the original owner of the HHT appliance at the site of installation, and to any transferee taking ownership of the appliance at the site of installation within two years following the date of original purchase, that the HHT appliance will be free from defects in materials and workmanship at the time of manufacture. After installation, if covered components manufactured by HHT are found to be defective in materials or workmanship during the applicable warranty period, HHT will, at its option, repair or replace the covered components. HHT, at its own discretion, may fully discharge all of its obligations under such warranties by replacing the product itself or refunding the verified purchase price of the product itself. The maximum amount recoverable under this warranty is limited to the purchase price of the product. This warranty is subject to conditions, exclusions and limitations as described below.

WARRANTY PERIOD:

Warranty coverage begins on the date of installation. In the case of new home construction, warranty coverage begins on the date of first occupancy of the dwelling or six months after the sale of the product by an independent, authorized HHT dealer/ distributor, whichever occurs earlier. The warranty shall commence no later than 24 months following the date of product shipment from HHT, regardless of the installation or occupancy date. The warranty period for parts and labor for covered components is produced in the following table.

The term "Limited Lifetime" in the table below is defined as: 20 years from the beginning date of warranty coverage for gas appliances, and 10 years from the beginning date of warranty coverage for wood, pellet, and coal appliances. These time periods reflect the minimum expected useful lives of the designated components under normal operating conditions.

Warranty Period		HHT Manufactured Appliances and Venting							Components Covered
Parts	Labor	Gas	Wood	Pellet	EPA Wood	Coal	Electric	Venting	
1 Year		X	X	X	X	X	X	X	All parts and material except as covered by Conditions, Exclusions, and Limitations listed
2 years				X	X	X			Igniters, electronic components, and glass
		X	X	X	X	X			Factory-installed blowers
			X						Molded refractory panels
3 years				X					Firepots and burnpots
5 years	1 year			X	X				Castings and baffles
7 years	3 years		X	X	X				Manifold tubes, HHT chimney and termination
10 years	1 year	X							Burners, logs and refractory
Limited Lifetime	3 years	X	X	X	X	X			Firebox and heat exchanger
90 Days		X	X	X	X	X	X	X	All replacement parts beyond warranty period

See conditions, exclusions, and limitations on next page.

WARRANTY CONDITIONS:

- This warranty only covers HHT appliances that are purchased through an HHT authorized dealer or distributor. A list of HHT authorized dealers is available on the HHT branded websites.
- This warranty is only valid while the HHT appliance remains at the site of original installation.
- Contact your installing dealer for warranty service. If the installing dealer is unable to provide necessary parts, contact the nearest HHT authorized dealer or supplier. Additional service fees may apply if you are seeking warranty service from a dealer other than the dealer from whom you originally purchased the product.
- Check with your dealer in advance for any costs to you when arranging a warranty call. Travel and shipping charges for parts are not covered by this warranty.

WARRANTY EXCLUSIONS:

This warranty does not cover the following:

- Changes in surface finishes as a result of normal use. As a heating appliance, some changes in color of interior and exterior surface finishes may occur. This is not a flaw and is not covered under warranty.
- Damage to printed, plated, or enameled surfaces caused by fingerprints, accidents, misuse, scratches, melted items, or other external sources and residues left on the plated surfaces from the use of abrasive cleaners or polishes.
- Repair or replacement of parts that are subject to normal wear and tear during the warranty period. These parts include: paint, wood, pellet and coal gaskets; firebricks; grates; flame guides; and the discoloration of glass.
- Minor expansion, contraction, or movement of certain parts causing noise. These conditions are normal and complaints related to this noise are not covered by this warranty.
- Damages resulting from: (1) failure to install, operate, or maintain the appliance in accordance with the installation instructions, operating instructions, and listing agent identification label furnished with the appliance; (2) failure to install the appliance in accordance with local building codes; (3) shipping or improper handling; (4) improper operation, abuse, misuse, continued operation with damaged, corroded or failed components, accident, or improperly/incorrectly performed repairs; (5) environmental conditions, inadequate ventilation, negative pressure, or drafting caused by tightly sealed constructions, insufficient make-up air supply, or handling devices such as exhaust fans or forced air furnaces or other such causes; (6) use of fuels other than those specified in the operating instructions; (7) installation or use of components not supplied with the appliance or any other components not expressly authorized and approved by HHT; (8) modification of the appliance not expressly authorized and approved by HHT in writing; and/or (9) interruptions or fluctuations of electrical power supply to the appliance.
- Non-HHT venting components, hearth components or other accessories used in conjunction with the appliance.
- Any part of a pre-existing fireplace system in which an insert or a decorative gas appliance is installed.
- HHT's obligation under this warranty does not extend to the appliance's capability to heat the desired space. Information is provided to assist the consumer and the dealer in selecting the proper appliance for the application. Consideration must be given to appliance location and configuration, environmental conditions, insulation and air tightness of the structure.

This warranty is void if:

- The appliance has been over-fired or operated in atmospheres contaminated by chlorine, fluorine, or other damaging chemicals. Over-firing can be identified by, but not limited to, warped plates or tubes, rust colored cast iron, bubbling, cracking and discoloration of steel or enamel finishes.
- The appliance is subjected to prolonged periods of dampness or condensation.
- There is any damage to the appliance or other components due to water or weather damage which is the result of, but not limited to, improper chimney or venting installation.

LIMITATIONS OF LIABILITY:

- The owner's exclusive remedy and HHT's sole obligation under this warranty, under any other warranty, express or implied, or in contract, tort or otherwise, shall be limited to replacement, repair, or refund, as specified above. In no event will HHT be liable for any incidental or consequential damages caused by defects in the appliance. Some states do not allow exclusions or limitation of incidental or consequential damages, so these limitations may not apply to you. This warranty gives you specific rights; you may also have other rights, which vary from state to state. EXCEPT TO THE EXTENT PROVIDED BY LAW, HHT MAKES NO EXPRESS WARRANTIES OTHER THAN THE WARRANTY SPECIFIED HEREIN. THE DURATION OF ANY IMPLIED WARRANTY IS LIMITED TO DURATION OF THE EXPRESSED WARRANTY SPECIFIED ABOVE.

QUADRA-FIRE®

CONTACT INFORMATION:

Hearth & Home Technologies
1445 North Highway
Colville, WA 99114
Division of HNI INDUSTRIES
www.quadrafire.com

Please contact your Quadra-Fire dealer with any questions or concerns.
For the number of your nearest Quadra-Fire dealer
visit our website at www.quadrafire.com

NOTICE



DO NOT DISCARD THIS MANUAL

• Important operating and maintenance instructions included.

• Read, understand and follow these instructions for safe installation and operation.

• Leave this manual with party responsible for use and operation.

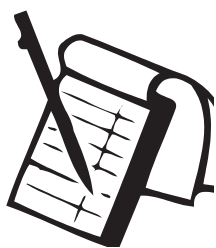

We recommend that you record the following pertinent information for your CB1200-I PELLET INSERT

Date purchased/installed: _____

Serial Number: _____ Location on appliance: _____

Dealership purchased from: _____ Dealer phone: _____

Notes: _____

This product may be covered by one or more of the following patents: (United States) 4593510, 4686807, 4766876, 4793322, 4811534, 5000162, 5016609, 5076254, 5113843, 5191877, 5218953, 5263471, 5328356, 5341794, 5347983, 5429495, 5452708, 5542407, 5601073, 5613487, 5647340, 5688568, 5762062, 5775408, 5890485, 5931661, 5941237, 5947112, 5996575, 6006743, 6019099, 6048195, 6053165, 6145502, 6170481, 6237588, 6296474, 6374822, 6413079, 6439226, 6484712, 6543698, 6550687, 6601579, 6672860, 6688302B2, 6715724B2, 6729551, 6736133, 6748940, 6748942, 6769426, 6774802, 6796302, 6840261, 6848441, 6863064, 6866205, 6869278, 6875012, 6880275, 6908039, 6919884, D320652, D445174, D462436; (Canada) 1297749, 2195264, 2225408, 2313972; (Australia) 780250, 780403, 1418504 or other U.S. and foreign patents pending.

