

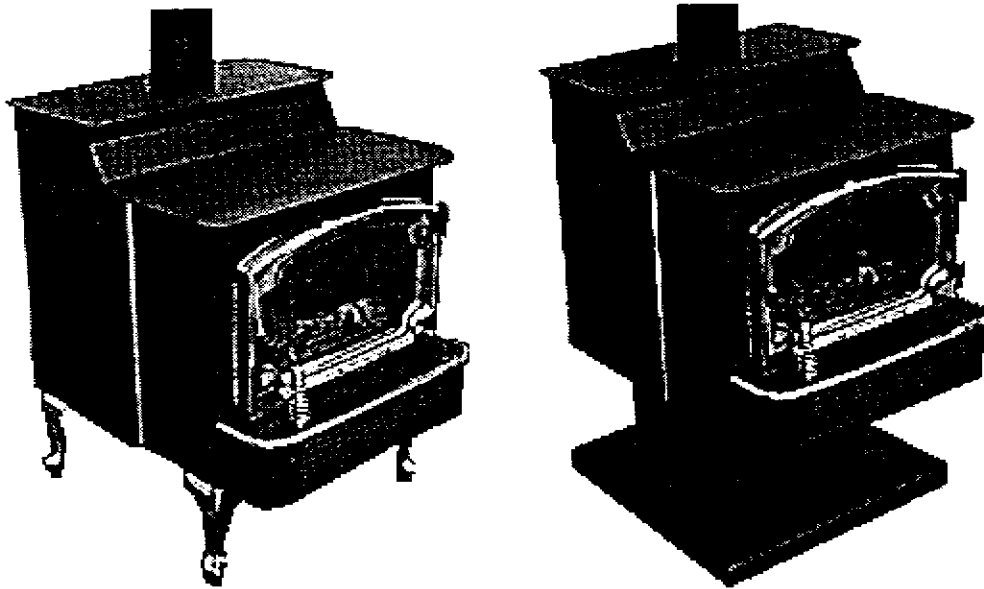

Owner's Manual

- March, 1994 -



WARNING: If the information in this manual is not followed exactly, a fire or explosion may result causing property damage, personal injury or loss of life.

- Do not store or use gasoline or other flammable vapors and liquids in the vicinity of this or any other appliance.
- **WHAT TO DO IF YOU SMELL GAS**
 - Do not try to light any appliance.
 - Do not touch any electrical switch; do not use any phone in your building.
 - Immediately call gas supplier from a neighbor's phone. Follow the gas supplier's instructions.
 - If you cannot reach your gas supplier, call the fire department.
- Installation and service must be performed by a qualified installer, service agency or the gas supplier.

300 GS - Gas Stove Room Heater

 **Travis Industries, Inc.**
10850 117th Place N.E. Kirkland, WA 98033

Warnock Hersey
 Listed

SAFETY PRECAUTIONS

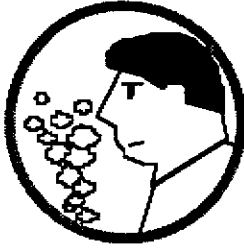

• IF YOU SMELL GAS:

- * Do not light any appliance
- * Extinguish any open flame
- * Do not touch any electrical switch or plug or unplug anything
- * Open windows and vacate building
- * Call gas supplier from neighbor's house, if not reached, call fire department

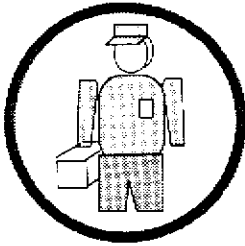

- This unit must be installed by a qualified installer to prevent the possibility of an explosion. Your dealer will know the requirements in your area and can inform you of those people considered qualified. The room heater should be inspected before use and at least annually by a qualified service person. More frequent cleaning may be required due to excessive lint from carpeting, bedding material, etc.
- The instructions in this manual must be strictly adhered to. Do not use makeshift methods or compromise in the installation. Improper installation will void the warranty and safety listing.



- Contact your local building officials to obtain a permit and information on any installation restrictions or inspection requirements in your area. Notify your insurance company of this heater as well.



- This heater is designed and approved for natural gas only. Propane or any other type of fuel burned in this heater will void the warranty and safety listing.

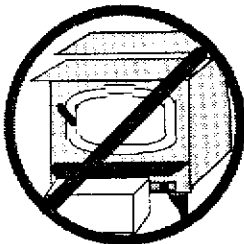

- It is imperative that control compartments, screens, or circulating air passageways of the heater be kept clean and free of obstructions. These areas provide the air necessary for safe operation.



- Do not operate the heater if it is not operating properly in any fashion or if you are uncertain. Call your dealer for a full explanation of your heater and what to expect.



- Do not store or use gasoline or other flammable liquids in the vicinity of this heater.

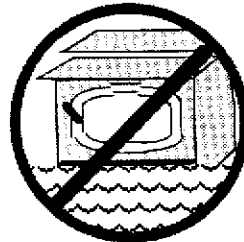

- Do not operate if any portion of the heater was submerged in water or if any corrosion occurs.

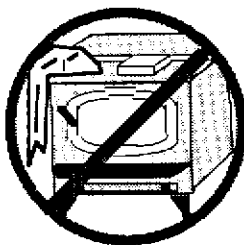

- Do not place clothing or other flammable items on or near the heater. Because this heater can be controlled by a thermostat there is a possibility of the heater turning on and igniting any items placed on or near it.



- Light the heater using the built-in piezo igniter. Do not use matches or any other external device to light your heater.

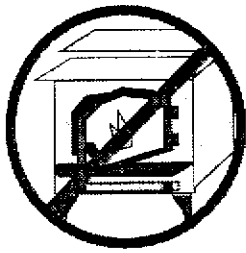

- The viewing door should be opened for service only (see the maintenance section of this manual).
- Any safety screen or guard removed for servicing must be replaced prior to operating the room heater.



- If the flame becomes sooty, dark orange in color, or extremely tall, do not operate the heater. Call your dealer and arrange for proper servicing.

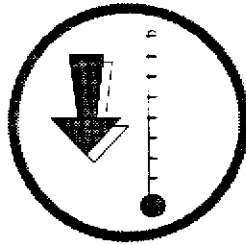

- Allow the heater to cool before carrying out any maintenance or cleaning.

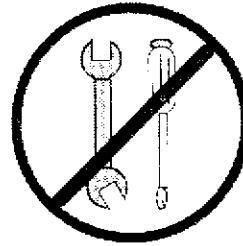

- Never remove, replace, modify or substitute any part of the heater unless instructions are given in this manual. All other work must be done by a trained technician. Do not modify or replace orifices.

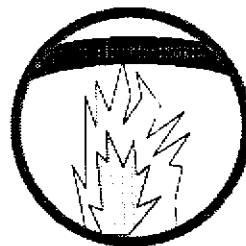

- Operate the heater according to the instructions included in this manual.
- If the main burners do not start correctly turn the gas off at the gas control valve and call your dealer for service.

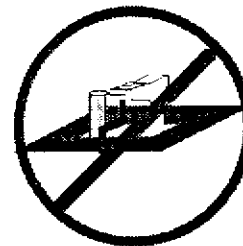

- Do not operate the heater if the pilot flame does not light – turn off the heater and call your dealer for service (see the operating instructions in this manual for lighting the pilot light if the pilot goes out).

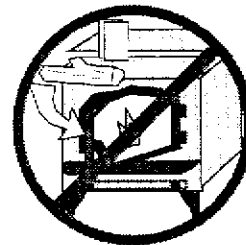

- Do not place anything inside the firebox (except the included fiber logs).
- If the fiber logs become damaged, replace with Travis Industries fiber logs.



- Do not throw this manual away. This manual has important operating and maintenance instructions that you will need at a later time. Always follow the instructions in this manual.



- Do not touch the heater while it is hot and educate all children of the danger of a high-temperature heater. Young children should be supervised when they are in the same room as the heater.

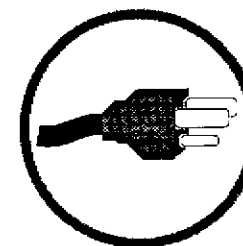

- The heater must be plugged into a 115 V. grounded electrical outlet for the blower to work correctly. Do not use an adapter plug or remove the grounding plug.
- Do not route the electrical cord in front of or over the heater.

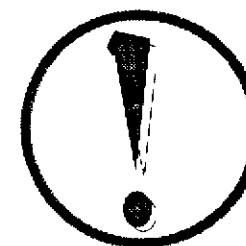

- **Travis Industries, Inc. grants no warranty, implied or stated, for the installation or maintenance of your heater, and assumes no responsibility of any consequential damage(s).**

General Information

Introduction & Important Information	1
Safety Precautions	2
Features & Specifications	5

Stove Installation

Heater Placement	6
Floor Protection	7
Vent Requirements	7
Gas Line Install	8
Finalizing the Installation	9

Operating Your Heater

Reviewing the Installation	10
Before You Begin	11
Location of Controls	11
Starting The Pilot	12
Running Your Heater	13
Starting the Heater for the First Time	13
Turning the Heater On and Off	14
Adjusting the Flame Height	15
Adjusting the Blower Speed	15
Normal Operating Sounds	15

Maintaining Your Heater

Inspecting the Firebox	16
Installing the Logs and Ember Strip	17
Inspecting the Door	18
Replacing the Door Gasket	19
Replacing the Glass or Glass Gasket	19

Troubleshooting

Troubleshooting Table	20
How this Heater Works	21
What Turns the Main Burners On and Off	21
Why Nothing Should Be Placed Against the Heater	21
What Prevents Gas Buildup	22
Wiring Diagram	23
Replacement Parts	23

Warranty

Warranty	24
----------------	----

Listing Information

Listing Information	25
---------------------------	----

Optional Equipment

Legs	26
Pedestal	26
Optional Remote Control	27
Optional Thermostat	29
Re-Routing the Power Cord to the Left or Rear of the Heater	31

Features:

- Works During Power Outages (utilizes millivolt system)
- High Efficiency (80% Steady State)
- Optional Thermostat or Remote Control
- Realistic "Wood Fire" Look
- Convenient Operating Controls
- Variable-Rate Heat Output
- Quiet Blower for Effective Heat Distribution
- Low Maintenance

Heating Specifications:

Approximate Maximum Heating Capacity (in square feet)*	600 - 1600
High Burn Input Rate (In Natural Gas BTU's)**	31,000
Low Burn Input Rate (In Natural Gas BTU's)**	19,000

- * Heating capacity will vary depending on the home's floor plan, degree of insulation, and the outside temperature. It is also affected by the natural gas BTU rating.
- ** The input rates are rated in Natural Gas BTU's which are equivalent to 1000 BTU's per cubic feet. To measure actual BTU's of the heater, multiply the BTU input by the efficiency percentage (80%).

300 GS Dimensions

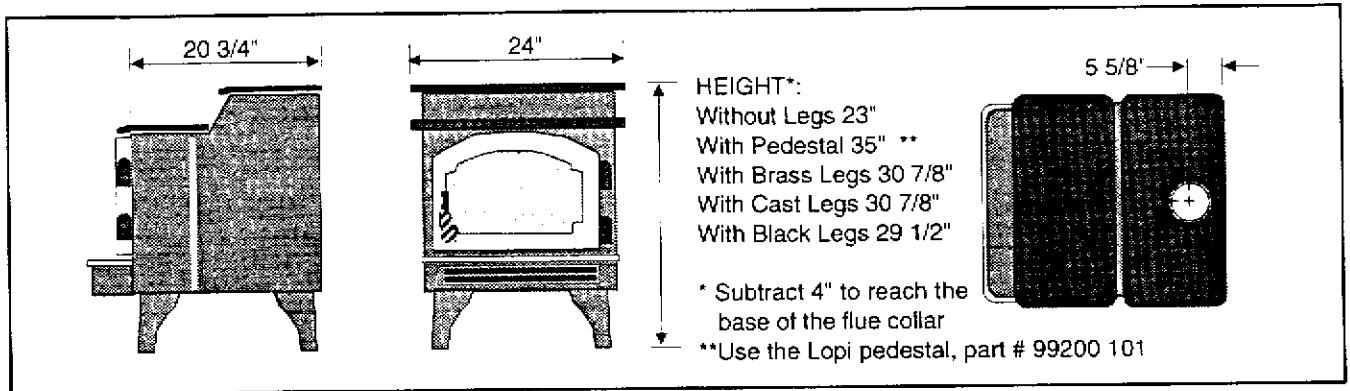

Vent Opening Diameter = 4" (Both)

Weight = 175 Pounds

Electrical Specifications:

Blower Electrical Rating:..... 115 Volts, 1.3 Amps, 60 Hz (150 watts on high)

Fuel:

The heater is designed for natural gas only.

Emissions:

This unit has passed the ANSI emission standards for vented room heaters as tested by Warnock Hersey, LTD.

This appliance must be installed in accordance with all local codes, if any; if not, follow ANSI Z223.1 and the requirements listed in this manual. Failure to follow all of the requirements may result in property damage, bodily injury, or even death.

Check with local building officials for any permits required for installation of this gas heater and notify your insurance company before hooking up this heater. The requirements listed below are divided into sections. All requirements must be met simultaneously. The order of installation is not rigid – the qualified installer should follow the procedure best suited for the installation.

Heater Placement

The heater must be placed so the following requirements are met:

- Stove must be placed so that no combustibles are within, or can swing within (e.g. drapes, doors), 36" of the front of the heater
- The stove must be placed on a set of Travis Industries legs or pedestal
- When placed in a location where the floor to ceiling height is under 7 feet, the installation is considered an alcove and must meet the following requirements:
 - The alcove floor to ceiling height must be at least 58" tall
 - The alcove must not be more than 45" deep (before the ceiling returns to 7 feet)
- Heater and floor protection must be installed on a level, secure floor
- The stove must not be placed so the vents below the ashlip, above the door, along the sides of stove, or along the back of the heater can become blocked

STRAIGHT INSTALLATION (see the illustration below)

- 10" clearance from the top of the heater to the sidewall
- 3" clearance from the top of the heater to the backwall

CORNER INSTALLATION (see the illustration below)

- 4" clearance from the rear top corner of heater to the cornerwall (at a 45° angle)



HINT: REDUCING CLEARANCES - Clearances may be reduced by methods specified in NFPA 211, listed wall shields, pipe shields, or other means approved by local building or fire officials.

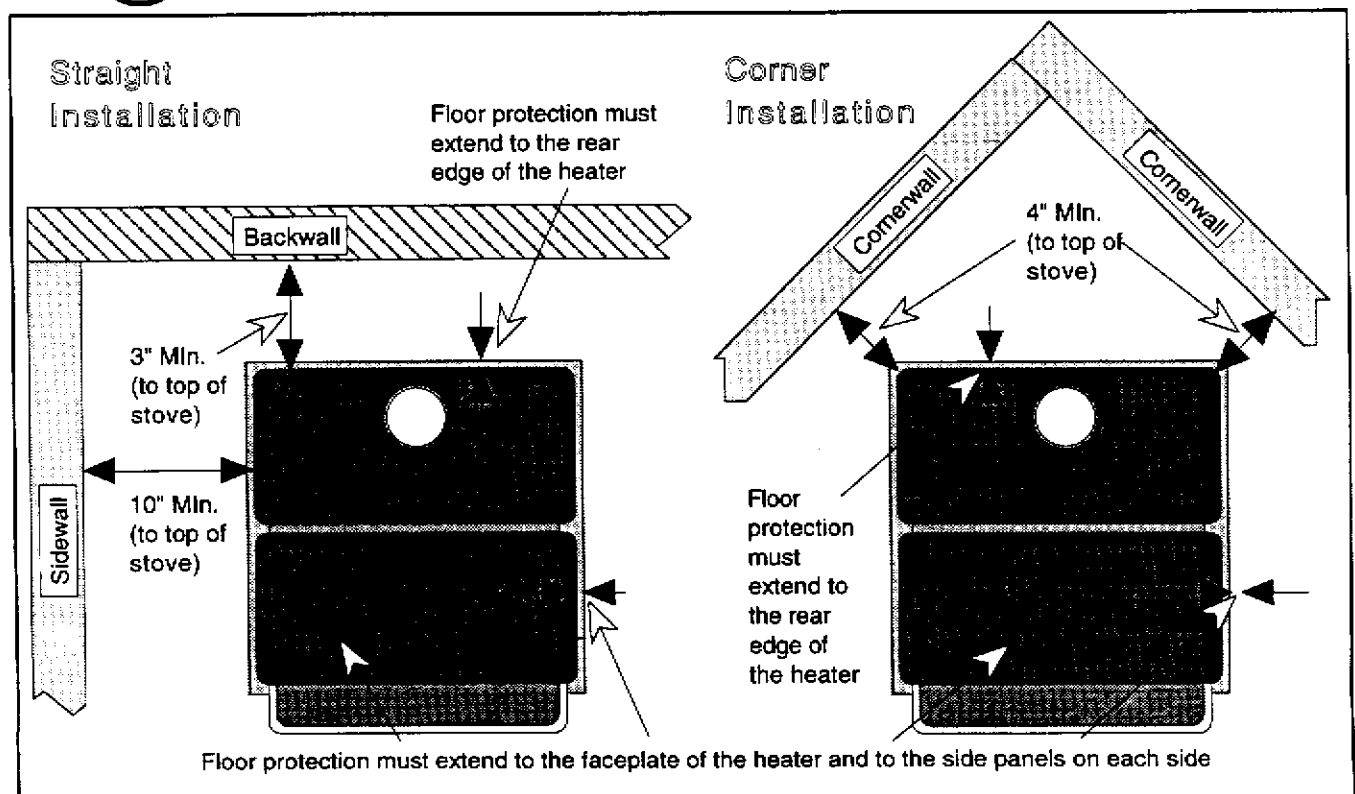

Floor Protection

The heater must be installed over floor protection that meets the following requirements:

- Made of a non-combustible material at least .018" thick (26 gauge)
- Must cover the area underneath the heater from the faceplate to the rear edge, extending to the side as far as the side panels (20 3/4" deep by 24" wide – see the illustration on the preceding page).

Vent Requirements

The vent must be installed in accordance with all local codes, if any; if not, follow ANSI Z223.1 and the requirements listed below. Furthermore, the vent must be installed to meet the installation requirements of the vent manufacturer.



HINT: Call your local building official to obtain the building code that is used in your area. Most building codes follow the requirements specified in ANSI Z223.1 (to obtain a copy call 212 642-4900).

This heater must be installed with a vent that meets the following requirements:

- Minimum of 5' vertical rise from top of stove
- 4" diameter B vent for entire system from one manufacturer (don't mix brands)
- The vent must not service another appliance
- 1" clearance to all combustibles must be maintained
- Must meet all of the vent manufacturer's requirements

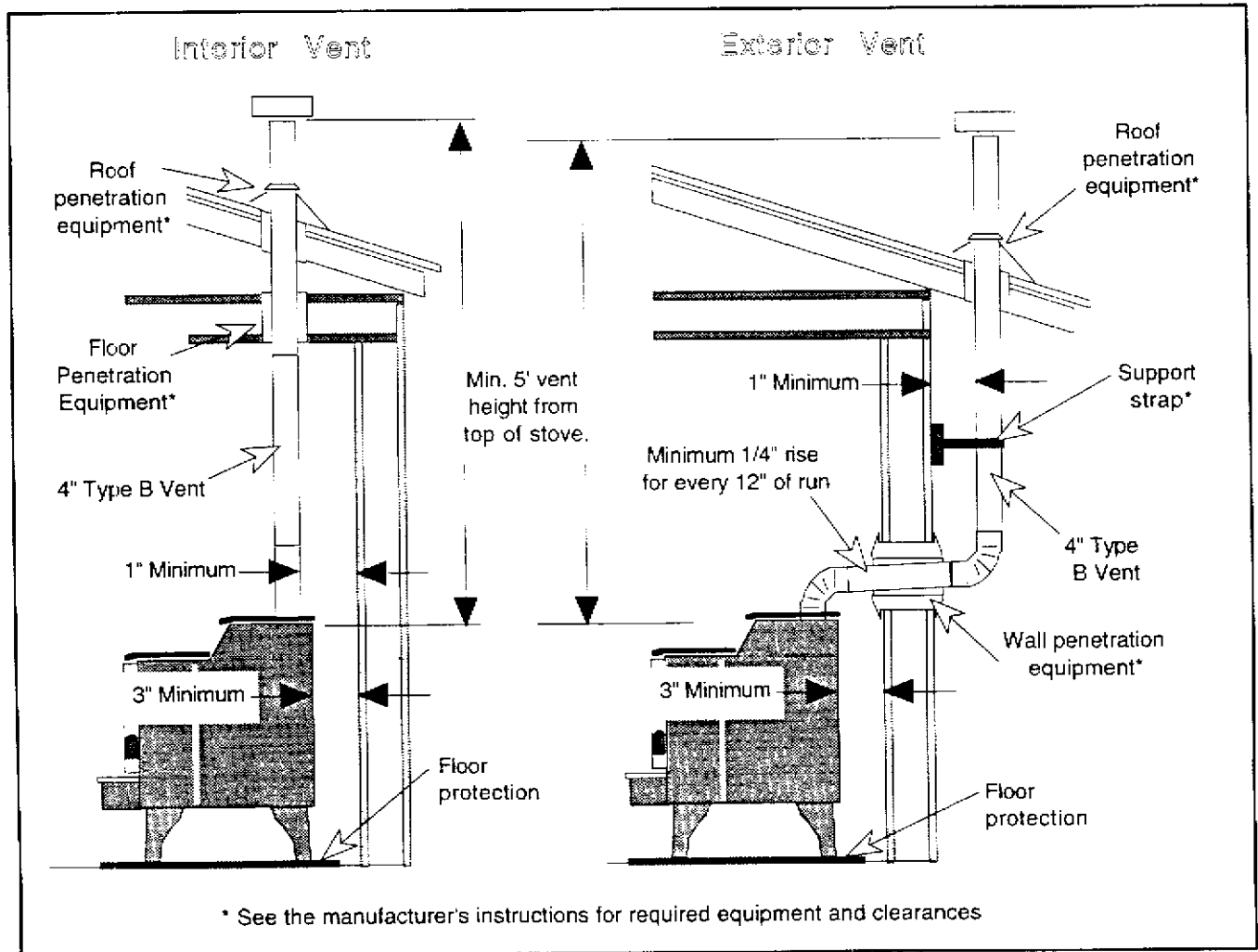

The vent termination must meet the following requirements:

- Must have an approved cap (to prevent water from entering)
- Must not be located where it will become plugged by snow or other material
- Must not be located below eaves or overhangs
- Must be 1' above the roof **and** meet the requirements outlined in ANSI 223.1, section 7.6.2.

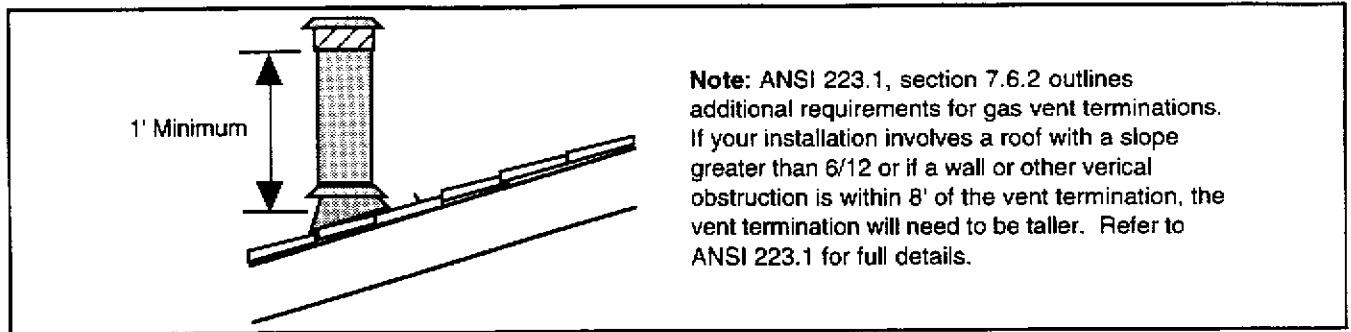
**Gas Line Install**

The gas line must be installed in accordance with all local codes, if any; if not, follow ANSI 223.1 and the requirements listed below.

Gas Line Connection Considerations:

- The flexible stainless steel flexible tubing from the heater has a 1/2" NPT fitting
- The shutoff valve is located directly upstream of the flexible inlet. If it is removed it must be replaced with a different shutoff valve. Generally, most codes require this valve be accessible and within 3 feet of the heater.
- The location of the inlet is shown below, along with the allowable bend.

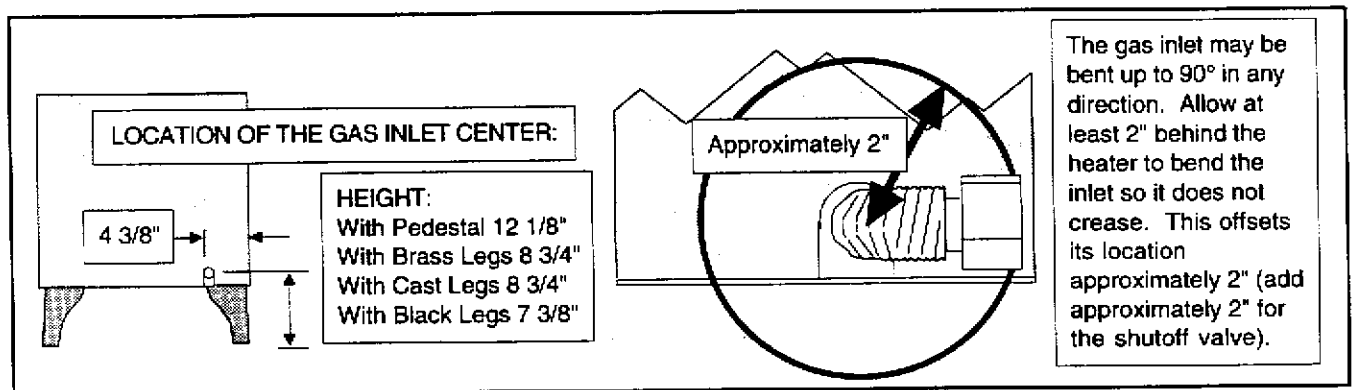

Gas Line Connection Considerations (Continued):

- The gas line diameter running to the heater must be an adequate size for the distance it runs from the supply regulator. The table below describes the necessary inside diameter.

Pipe Length (Feet)	Schedule 40 Pipe Inside Dia.	Tubing, Type L Outside Dia.
0 to 10	1/2"	1/2"
10 to 40	1/2"	5/8"
40 to 100	1/2"	3/4"
100 to 150	3/4"	7/8"
150 to 200	3/4"	7/8"

Gas Pressure:

- This heater was designed for 7" of water column pressure (1.75 kPA). The minimum allowable pressure is 5.5" of water column (1.37 kPA). If the pressure is not sufficient, make sure the piping used is large enough, the supply regulator is adequately adjusted, and that the total gas load for the entire residence does not exceed the amount supplied. The gas inlet to the heater must not exceed 10.5" of water column (2.6 kPA). The supply regulator (the regulator that attaches directly to the residence inlet) typically supplies gas at 7" of water column (1.75 kPA), which would eliminate over-pressurization.

Manifold Pressure:

The heater has a 1/8" N.P.T. tap located directly on the manifold. This allows the installer to check the pressure of the gas downstream of the valve. If the manifold pressure is does not fall within the limits below, check the inlet gas pressure and correct the problem.

- 3.5" (.87 kPA) water column with the flame height turned to high.
- 1.0" (.25 kPA) water column with the flame height turned to low.

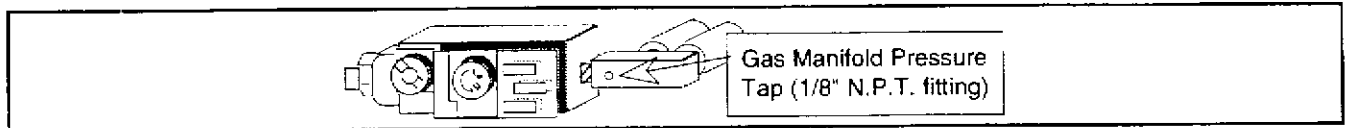

Purging the Gas Line:

The gas line should be properly purged to release all air in the gas line prior to starting the heater.

Finalizing the Installation

All optional equipment should be installed and the ceramic logs placed inside the firebox (see the optional equipment instructions included with this manual and the section "Installing the Logs and Ember Strip" found in the maintenance section of this manual). Then the heater should be started and checked for proper performance. The installer should review the operations portion of this manual to make sure the owner understands the operation of the heater.

Note: See the instructions "Re-Routing the Power Cord to the Left or Rear of the Heater" in the optional equipment section of this manual to re-route the power cord.

The check off list below details the installation concerns that you, the consumer, should know prior to starting the heater. This information is very important and must be checked off.

- () There are no combustible items placed within 36" of the front of the heater or swing within 36" of the front of heater. This includes furniture, doors, drapes, etc.

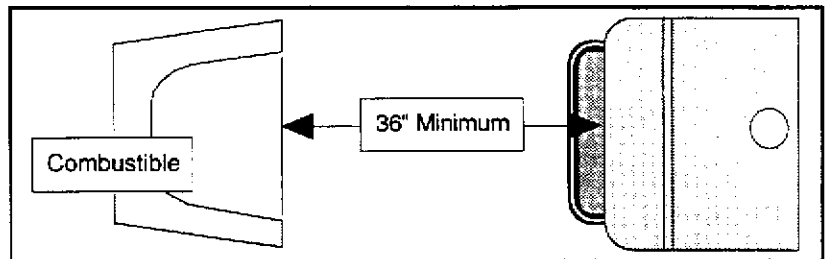

- () No combustibles are within 1" of the exhaust vent. Due to high temperatures, the room heater should be located out of traffic and away from combustibles. This includes drywall, drapes, window sills, etc. If any question exists, call your dealer for a full explanation.

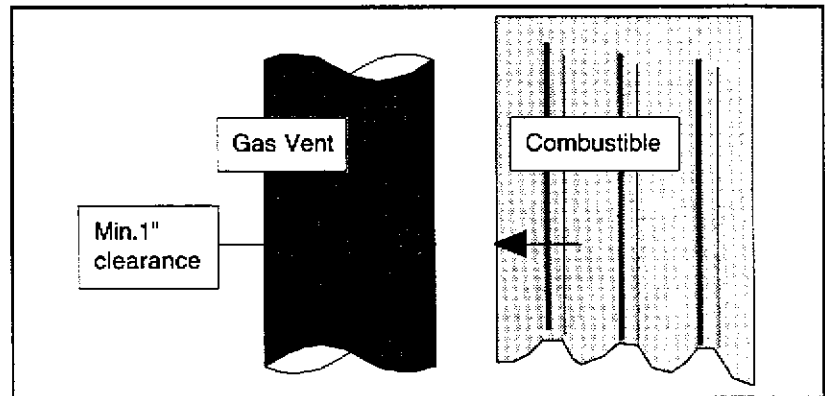

- () The location of the GAS MAIN SHUTOFF VALVE is known. It is usually directly next to the gas meter and may require a wrench to shut off. Everyone in the house should know where the gas main shutoff valve is and how to turn it off.

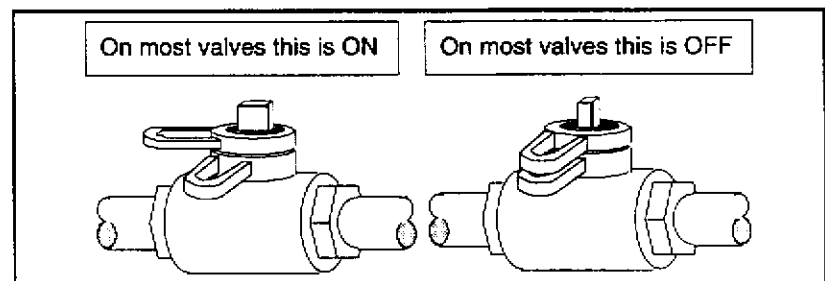

- () All of the necessary permits and installation information have been obtained for your records. This includes the permits from building officials, receipts, and this manual.

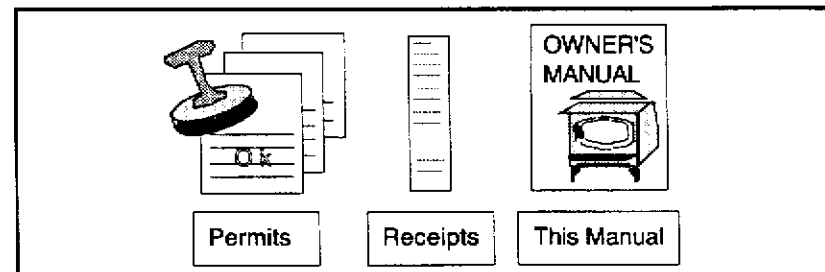

- () The operation card included with the heater slides out from behind the access panel. If you can not find it, call your dealer for details. This card includes important operation information that must be kept with the heater at all times.

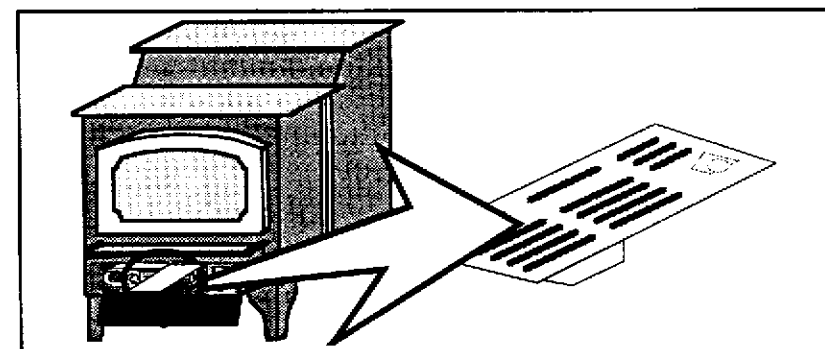

Before You Begin

READ THIS ENTIRE MANUAL BEFORE YOU USE YOUR NEW HEATER. FAILURE TO FOLLOW THE INSTRUCTIONS MAY RESULT IN PROPERTY DAMAGE, BODILY INJURY, OR EVEN DEATH.

Before starting your heater make sure you have read the section titled **Safety Precautions**. Any questions should be referred to your dealer.

Location of Controls - See explanation below

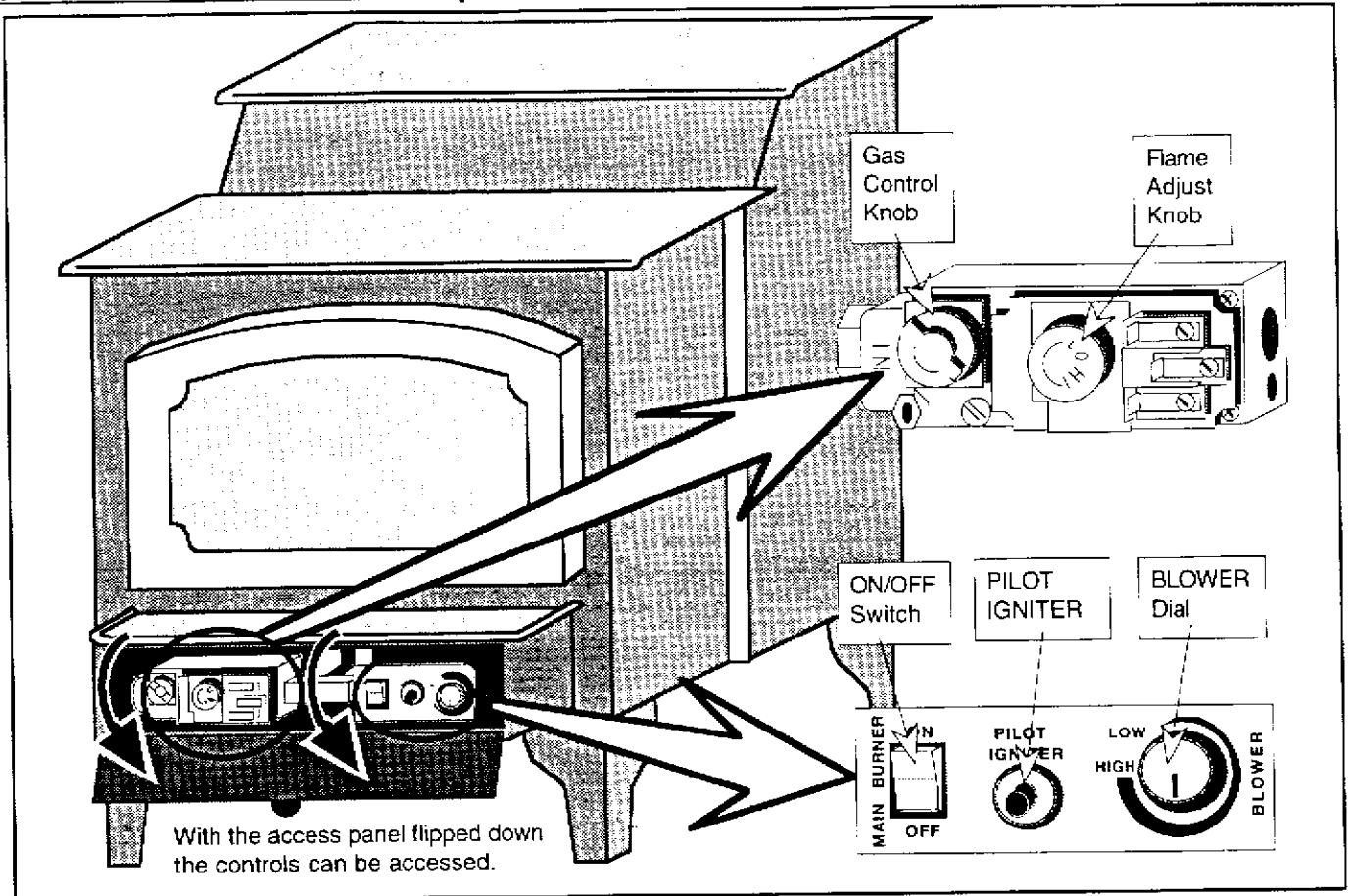

Gas Control Knob

This green knob is used for starting the pilot. There are three positions, ON, OFF, & PILOT. The pointer directly below the knob indicates the position this knob is in.

Flame Adjust Knob

This knob controls the flame height from low ("LO") to high ("HI"). The pointer to the upper right of the knob points to the position this knob is in.

ON/OFF Switch

This control is used to turn the heater on and off.

PILOT IGNITER

The pilot igniter is used only while starting the pilot. When pressed, it sends an electrical charge to the pilot assembly. This creates a blue spark directly next to the pilot light, igniting it.

BLOWER Dial

This dial controls the speed of the internal convection blower that pushes the heated air into the room.



NOTE:

The ON/OFF Switch must be left "ON" if using the remote control or thermostat. Turning the ON/OFF Switch to "OFF" will keep the heater off always.

Starting The Pilot

The pilot light is used to ignite the main burners when the stove is turned on and also provides an important safety role. It will stay lit once it is started. However, the gas flowing to the pilot will shut off whenever the pilot goes out. If the pilot turns off frequently, call your dealer for information. To start the pilot follow the directions below:

- A. Push the gas control knob in slightly and turn it to the "OFF" position. The knob will not turn from "ON" to "OFF" unless the knob is depressed slightly.

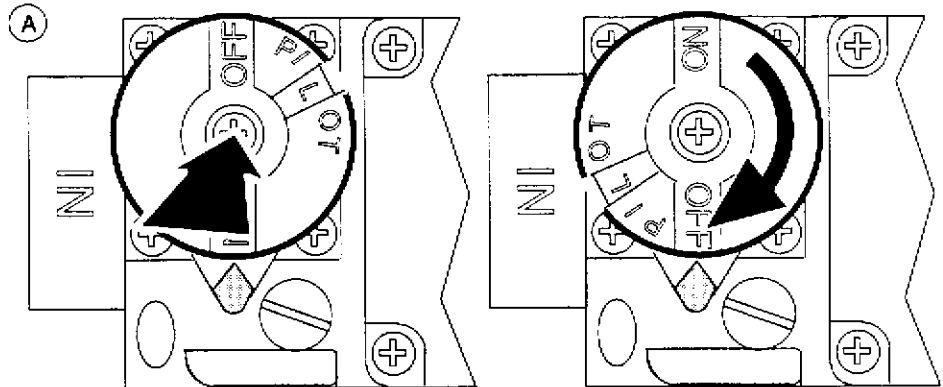

- B. Wait five minutes to let any gas that may have accumulated inside the firebox escape. If you smell gas, follow the directions on the cover "IF YOU SMELL GAS".

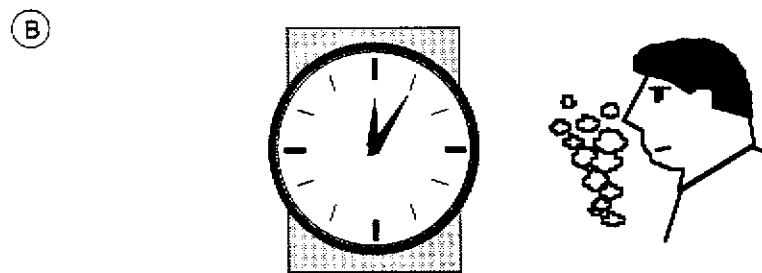

- C. Turn the gas control knob to the "PILOT" position and press the knob in, this will allow gas to flow to the pilot light. Press the red button on the pilot igniter repeatedly until you see the pilot light. **KEEP THE GAS CONTROL KNOB DEPRESSED FOR 30 SECONDS ONCE IT IS LIT.** Note: If the pilot does not light after several tries, call your dealer for service.

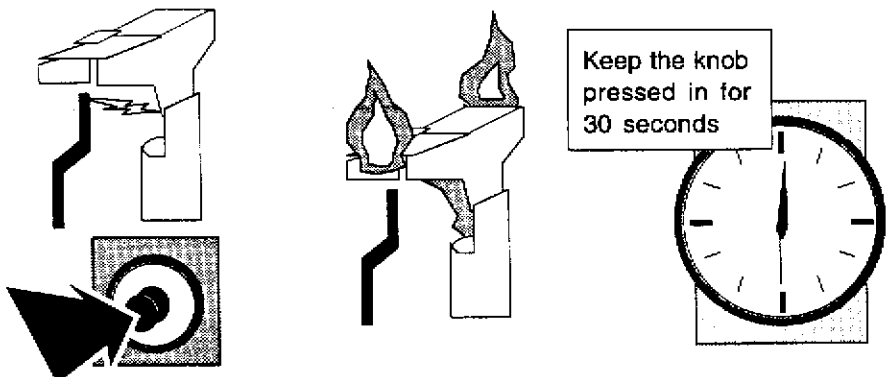
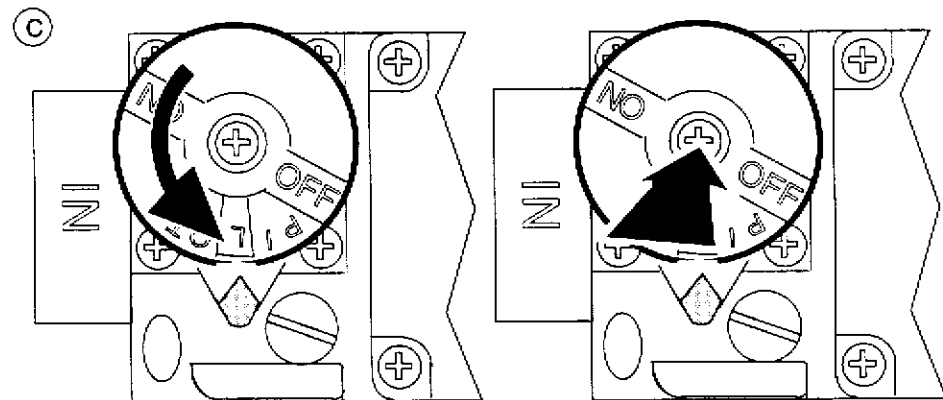

- D. Release the gas control knob. If the pilot goes out, repeat step C. If the pilot refuses to stay lit, call your dealer for service.

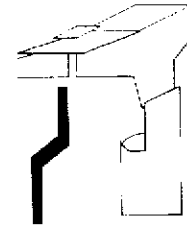
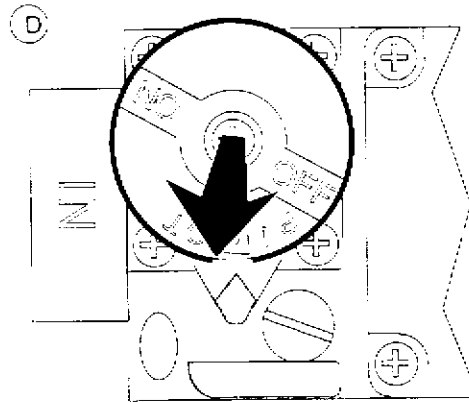

If the pilot light goes out after releasing the knob, repeat step C above.

- E. Turn the gas control knob counter-clockwise to "ON". The pilot is now lit and the heater can be turned on and off.

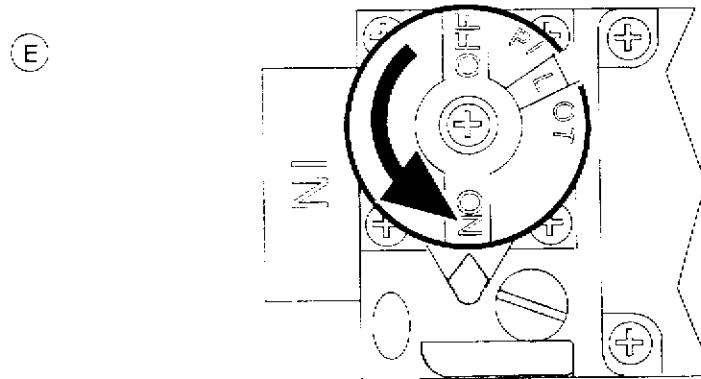

Running Your Heater

Your heater may be turned on and off manually, with the optional remote control, or by the optional thermostat. The speed of the blower and the height of the flame can also be adjusted manually.



NOTE: When the heater first comes on, the flames will be blue and somewhat transparent. After fifteen minutes the flames will turn a more realistic yellow and orange color.

NOTE: Certain installations use a remote "wall switch" to turn the heater on and off. If this is the case, leave the ON/OFF switch on "ON".

NOTE: When this switch is turned to the "OFF" position the main burner will not operate. However, the pilot flame will stay lit.

Starting the Heater for the First Time

The first time your heater gets up to temperature you will smell the paint on the outside of the heater curing. This is normal. We recommend that you first fire your heater with all of the windows open for a few hours during the first fire. Furthermore, the glass may become obscure during the first 10 hours of burning due to the components inside the firebox curing. Clean the glass with a glass cleaner after the first ten hours of operation.

Turning the Heater On and Off

• Manual Operation

After the pilot has been on for approximately one minute the heater may be turned on and off by pressing the ON/OFF switch located behind the access panel underneath the ashlip (see the illustration to the right).

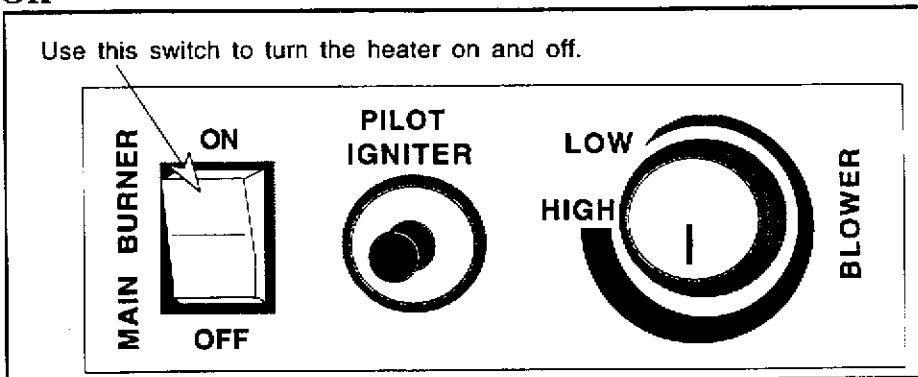

• Remote Control Operation (Optional)

The remote control turns the heater on from any location within the room. It utilizes a remote control and a receiver (usually located in the wall near the heater). Make sure the following has been done before trying to use the remote control: 1) The pilot is on; 2) The on/off switch is turned to "ON", and; 3) The switch on the remote control receiver is turned to "REMOTE" (see the illustration below). This switch can also be used to turn the heater on and off manually. The remote control requires two batteries, one in the remote and one in the remote control receiver. Both batteries must be charged for the remote control to work. If the remote control does not work, try replacing the batteries. If this doesn't work, contact your dealer for service.

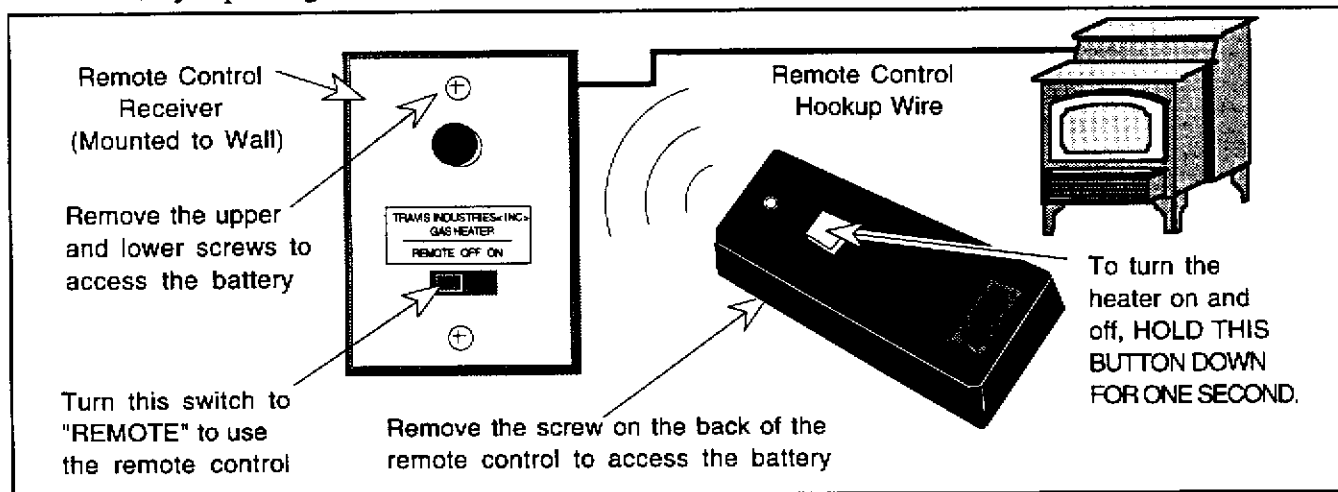

• Thermostat Operation (Optional)

After the pilot has been started the heater may be controlled by a thermostat. The on/off switch on the heater must be turned "ON" for the thermostat to operate. The thermostat will automatically turn the heater on and off depending on the temperature. If the thermostat does not turn the heater on, the thermostat may be set too low or the on/off switch may be turned "OFF". If the thermostat does not turn the heater off, the thermostat may be set too high. If the thermostat does not work after making these adjustments, call your dealer for service.

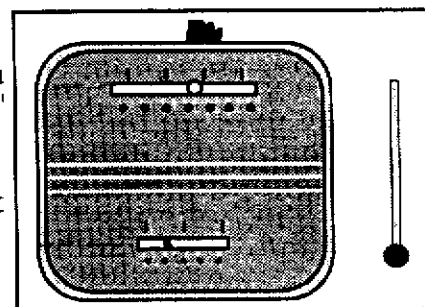

HINT:

If the heater turns on and off frequently, you may want to adjust the flame height down until it produces just enough heat needed. This keeps the thermostat from turning the heater on and off repeatedly.



WARNING:

Do not place any combustible items on top of the heater, even temporarily. The thermostat is automatic and may start the heater causing a combustible item to ignite.

Adjusting the Flame Height

Your heater has an adjustable flame to tailor the look and heat output to your specific needs. It is adjusted by turning the middle dial on the valve assembly.

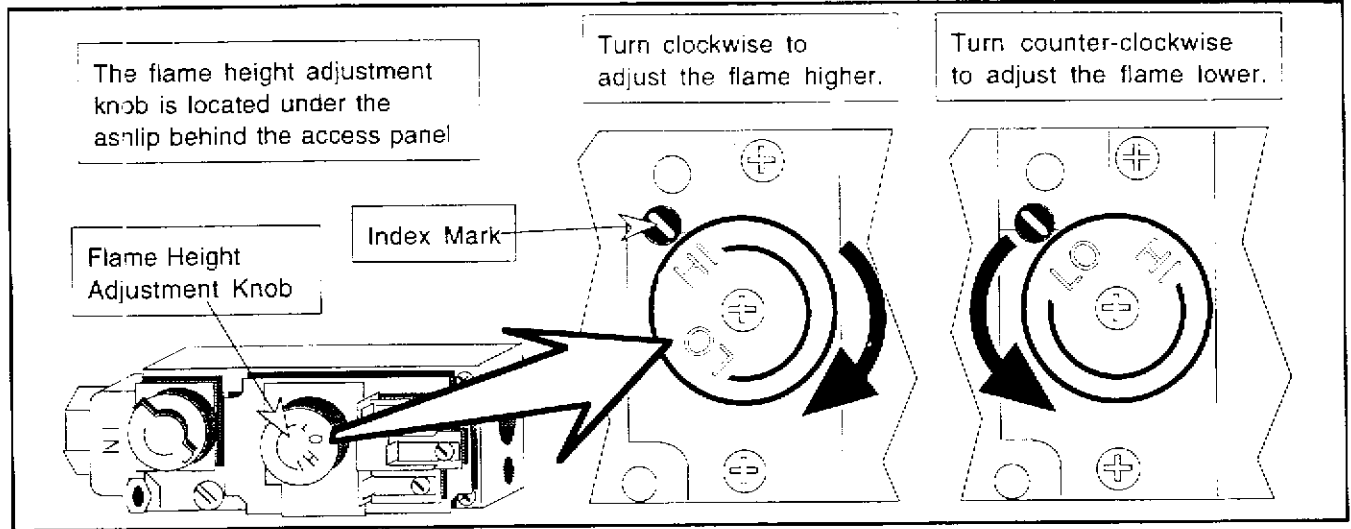

Adjusting the Blower Speed

The blower on your heater helps transfer the heat from the heater into the room. It will start blowing air once the heater is up to temperature and remain on until the heater has cooled down. See the illustration below for instructions on adjusting the blower speed.

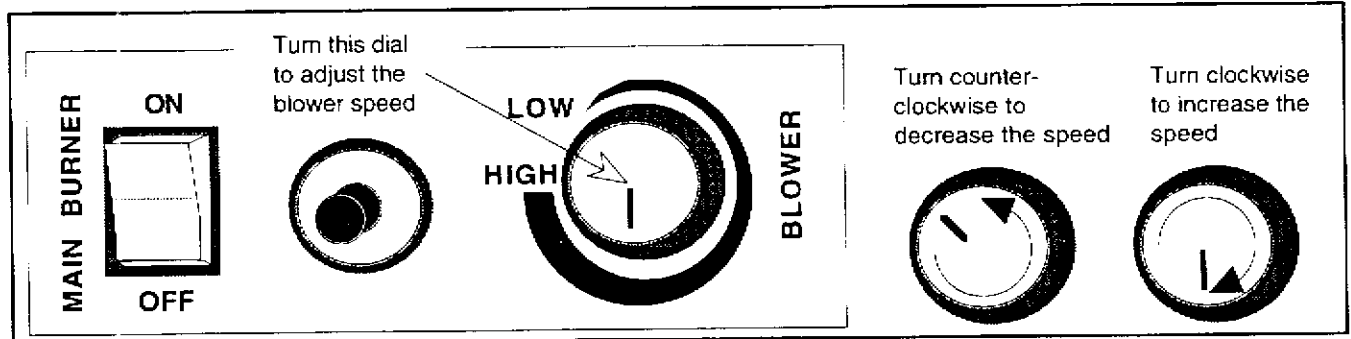

Normal Operating Sounds

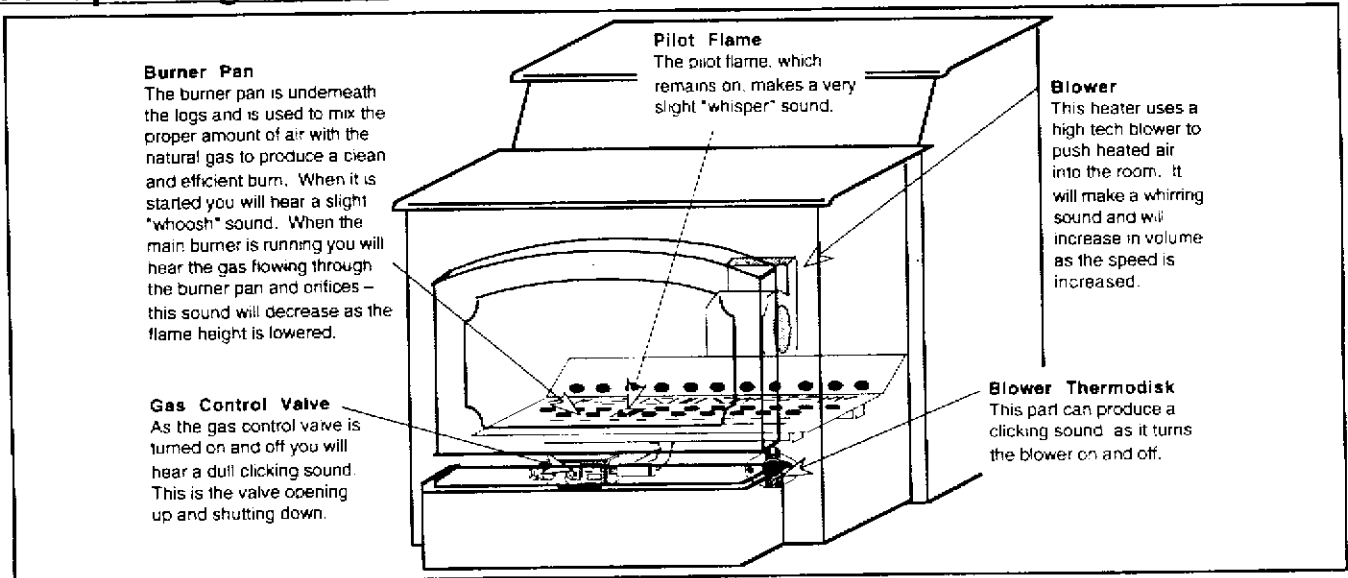

Every year you should inspect the firebox and door to make sure they are clean and functional.



WARNING: Failure to inspect and maintain your heater may lead to improper burning inside the heater, leading to a dangerous situation.

Inspecting the Firebox

The firebox should be inspected to insure the heater is working correctly. At this time it should also be cleaned of any soot or dust that may have been drawn into the heater. To do this, follow the directions below.

1. Open the door by unscrewing the door handle (see the illustration below). Swing the door open and lift it off the hinges to remove the door

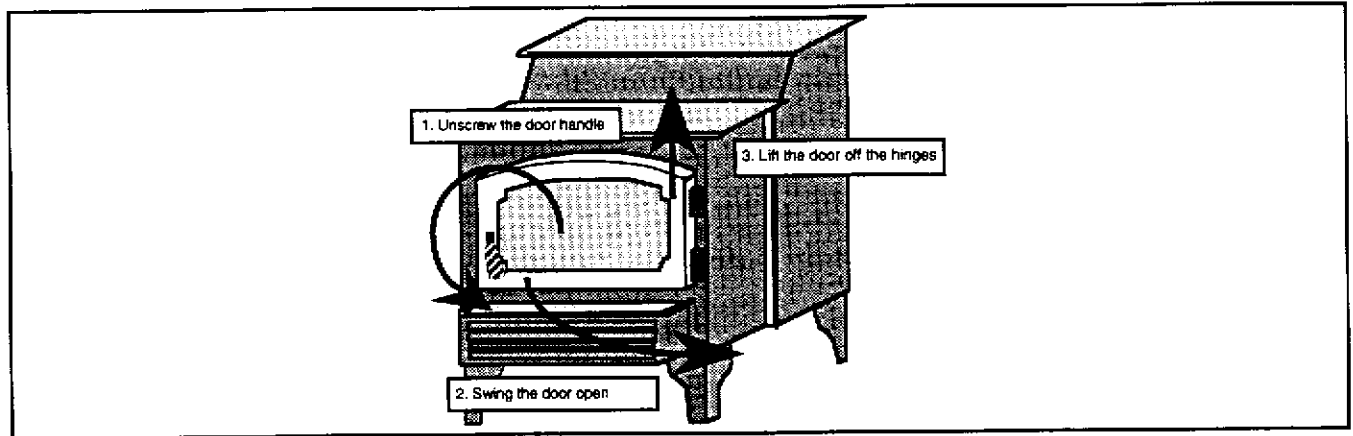

2. Remove the front log and ember strip by lifting them out of their holders.
3. Use a vacuum cleaner with a soft brush attachment to vacuum any dirt off the burner pan (see the illustration below). The rear log is fragile and should not be vacuumed. Inspect the burner pan and firebox for any deterioration. If it shows signs of deterioration, call your dealer for a full inspection. There should be no soot in the firebox, except for a small amount on the logs where the flames brush up against them. If there is additional soot, the heater may need adjustment. Contact your dealer for information.

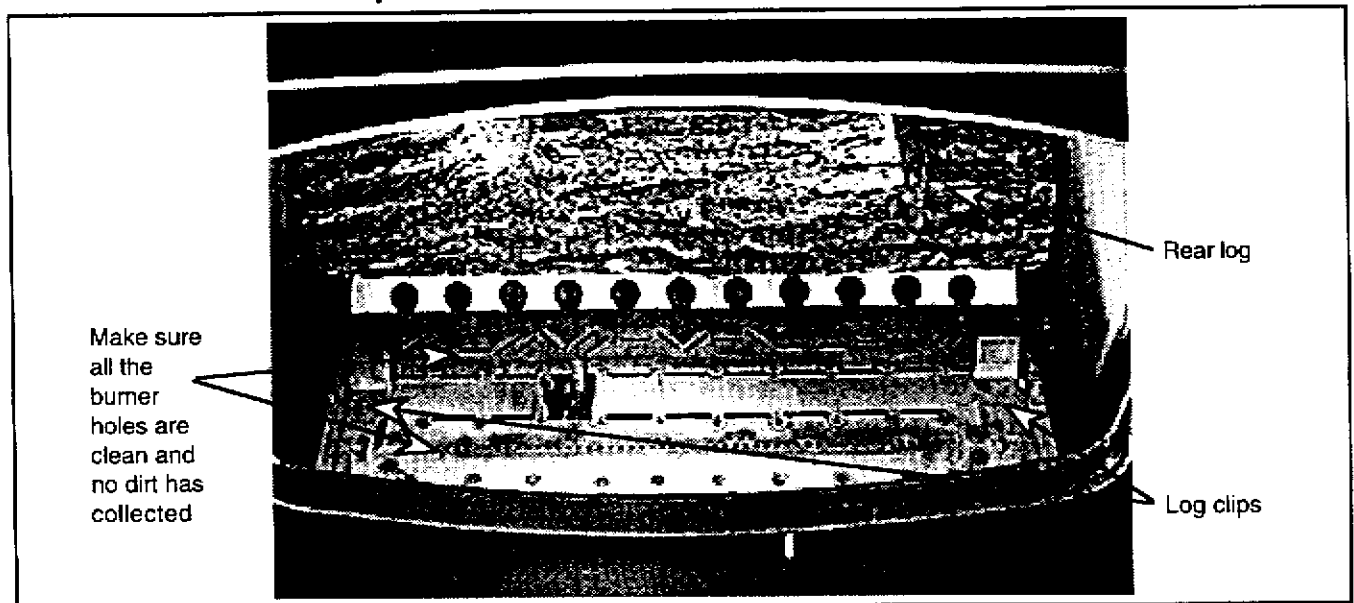

Inspecting the Firebox (Continued)

4. To replace the front log and ember strip follow the directions in the section "Installing the Logs and Ember Strip".
5. Replace the door. Turn the door handle clockwise until the door seals tight. **Make sure the handle faces outwards and is not in front of the glass.**

Installing the Logs and Ember Strip

The logs and ember strip are wrapped during shipping and will need to be properly placed before starting the heater. The other firebox components should be checked for proper placement before starting the heater. During annual maintenance the front log and ember strip must be removed for cleaning. They must be installed correctly, otherwise the heater will not burn properly. The instructions below detail the removal and installation of these items.

1. The rear log should rest on the rear edge of the burner pan (see the illustrations below).
2. The front log straddles the log clips on both sides of the burner pan.
3. The ember strip should be placed so that it is directly forward of the front burner holes and fits within the retainers on the log clip.

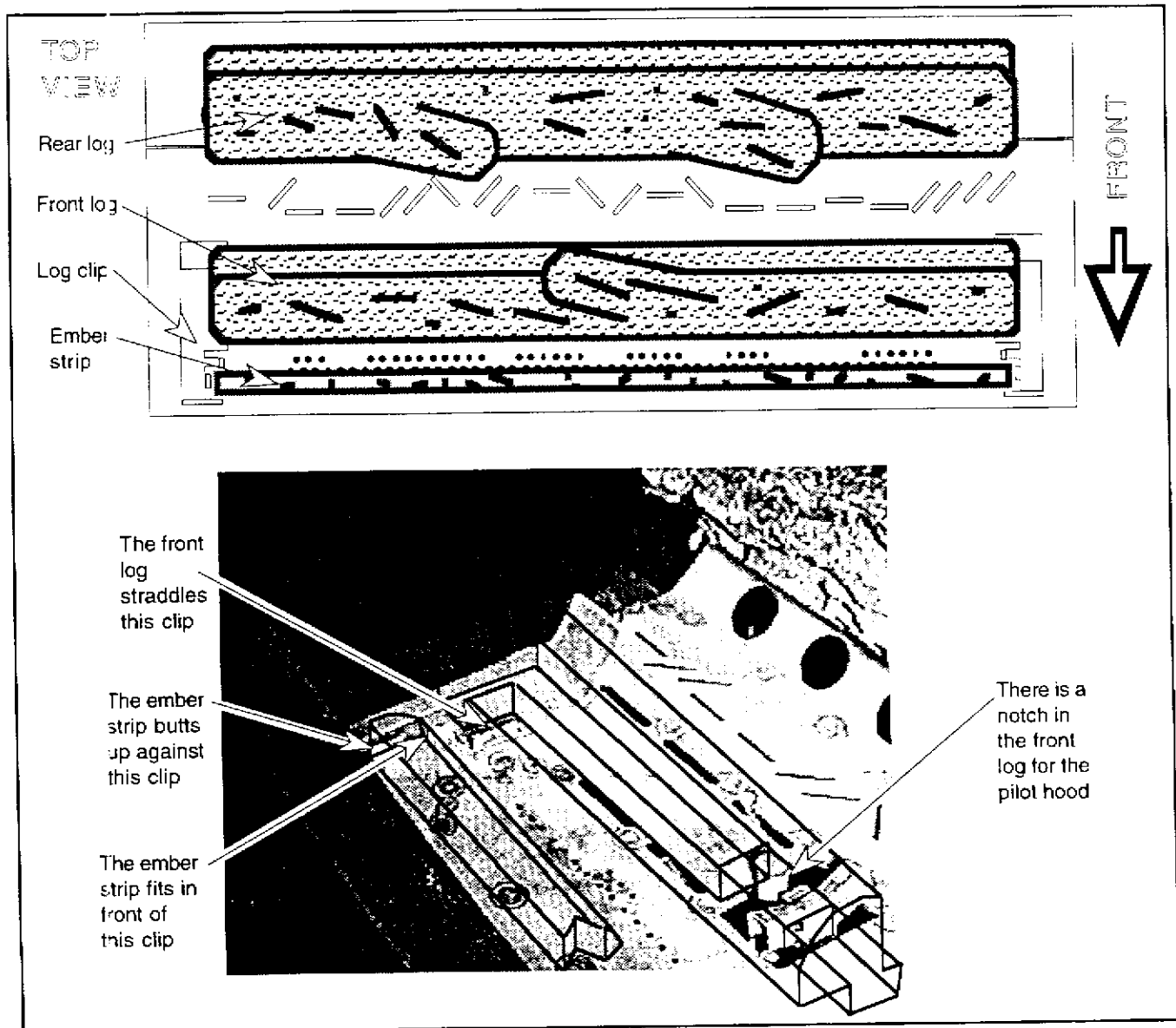

Inspecting the Door

The door must seal against the door seal for your heater to operate correctly. Follow the directions below to inspect the door.

1. Remove the door by following the instructions in the section "Inspecting the Firebox".
2. Place the door face down and check the door and glass gaskets for deterioration (see the illustration below). Replace the gaskets if necessary (see the instructions on the following page).
3. Then replace the door. Turn the door handle clockwise until the door seals tight. **Make sure the handle faces outwards and is not in front of the glass.**

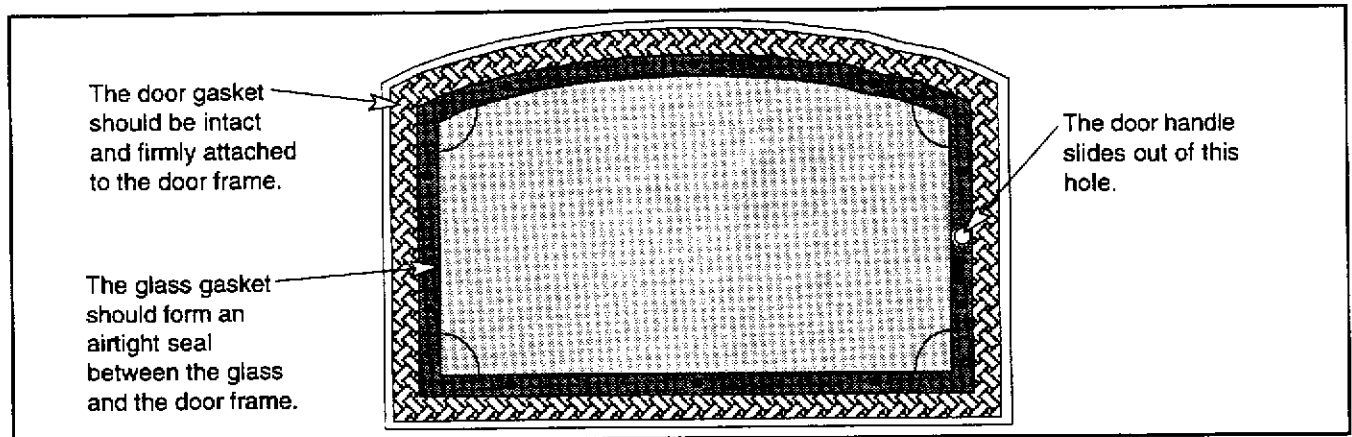

Replacing the Door Gasket

If the door gasket has deteriorated it will need to be replaced with a Lopi replacement door gasket. Remove the door by opening it and lifting it off the hinges. Remove the old gasket by stripping it away with a screwdriver or other tool (see the illustration below). Apply a line of gasket cement (available at your dealer) in the groove that follows the perimeter of the door. Insert the gasket into the groove. Do not stretch the gasket as you place it into the groove. Cut off any excess gasket when done. Allow 2 hours for the cement to dry. When re-installing the door, the gasket may need to be flattened by repeatedly opening and closing the door firmly.

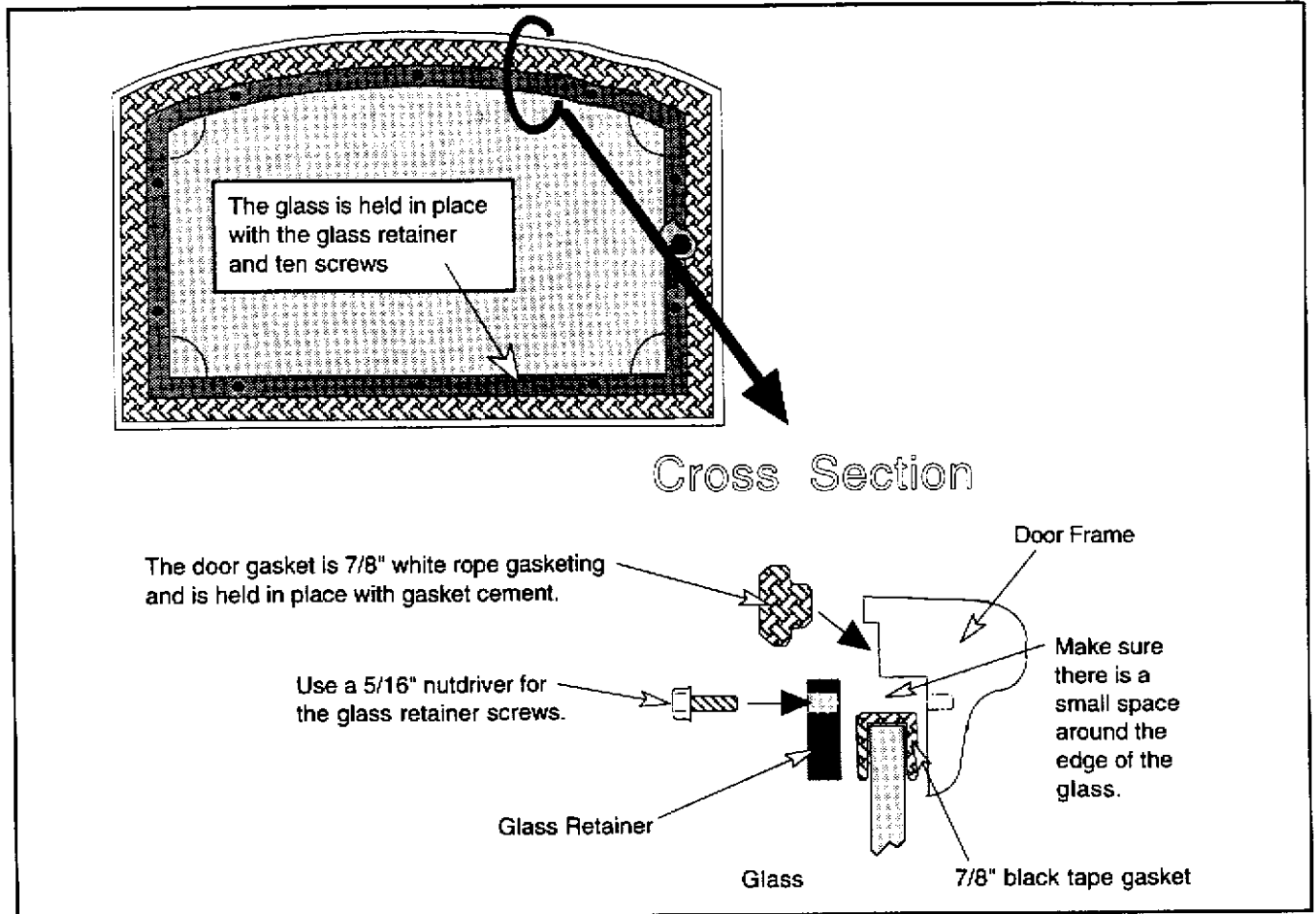

Replacing the Glass or Glass Gasket

If the glass has broken or if the gasket that seals the glass has deteriorated, the glass should be removed and a new gasket installed. Use only Lopi replacement glass and gasketing.

Remove the door by opening it and lifting it off the hinges. Remove the glass retainer by unscrewing the ten screws that hold it in place with a 5/16" nutdriver (see the illustration above). Carefully remove the glass. Make sure the 7/8" black tape gasket (new or old) runs along the perimeter of the glass. If using a new gasket, trim off any excess. Place the glass (new or old) in place so there is a small gap between the edge of the glass and the door frame. Make sure the gasket is tucked underneath the glass so the glass does not touch the door frame. Place the glass retainer in place and secure it with the screws removed earlier. Make sure the white gasket stays in place and seals the window. Tighten the glass retainer until the gaskets start to flatten.

Problem:	Possible Cause:	Don't Call for Service Until You:
Pilot Will Not Light	A gas shut off valve is turned off..... The valve control knob isn't turned to "PILOT"..... The valve control knob isn't pushed in..... The igniter wasn't pressed repeatedly.....	Check all gas shut off valves See "Starting the Pilot Light" Step C See "Starting the Pilot Light" Step C See "Starting the Pilot Light" Step C
Main Burners Will Not Start	The pilot light has gone out..... The ON/OFF switch is turned to "OFF"..... The remote control is not working correctly..... The thermostat is disconnected or set too high.....	See "Starting the Pilot Light" Turn the ON/OFF switch to "ON" See "Remote Control Operation" See "Thermostat Operation"
Remote Control Does Not Work	The pilot light has gone out..... The ON/OFF switch is turned to "OFF"..... The remote is too far away from the heater..... The remote control receiver is turned "Off" or "On"..... One of the two remote control batteries is dead.....	See "Starting the Pilot Light" Turn the ON/OFF switch to "ON" Use the remote closer to the heater See "Remote Control Operation" See "Remote Control Operation"
Thermostat Does Not Work	The pilot light has gone out..... The ON/OFF switch is turned to "OFF"..... The thermostat is set too high.....	See "Starting the Pilot Light" Turn the ON/OFF switch to "ON" See "Thermostat Operation"
Heater Will Not Distribute Heat	The heater is unplugged..... The heater is not up to temperature.....	Plug the heater in. See "Operating Your Heater"
Pilot Goes Out Once A Month Or More	The gas supply has not been shut off..... The vent is experiencing a cold air blockage or a negative pressure situation exists in the home.....	Keep the gas supply turned on This is a necessary safety feature that disables the heater if a down draft occurs. If this problem is persistent the vent may need to be improved or changes may need to be done to remove the negative pressure inside the home - see your dealer for details
Flame (and Pilot) Goes Out 10 to 25 Minutes After Starting	The vent is experiencing a cold air blockage or a negative pressure situation exists in the home.....	This is a necessary safety feature. First try restarting the heater. If it works correctly, a cold air blockage occurred and the vent just needed to be heated sufficiently. If this problem is persistent the vent may need to be improved or changes may need to be done to remove the negative pressure inside the home - see your dealer for details
Flames Are Too Blue	The heater has just been started.....	This is normal - see "Operating Your Heater"
Flames Are Orange With Dirty Smoke	Something may be placed against the heater.....	See "How this Heater Works"
Flames Are Too Short (Under 6")	The flame height may be turned too low..... Something may be placed against the heater.....	Turn the flame height to "HI" - See "Operating Your Heater" See "How this Heater Works"
Thin Layer of Soot Covers the Glass	The logs are placed incorrectly.....	See "Installing the Logs and Ember Strip"

How this Heater Works

This gas heater is designed with safety as the primary concern. Most of the components inside this heater are used for safety purposes. Therefore, only certified gas service technicians should service this heater. Your dealer can help you find a certified gas service technician.

What Turns the Main Burners On and Off

This heater uses a "millivolt system" to control its operation. A millivolt is a very small measurement of electricity. The thermopile, located directly next to the pilot light, generates electricity when it is heated by the pilot light. If the pilot is not lit, the thermopile does not generate electricity. This electricity is used to keep the gas valve open. Without it, the gas valve shuts off all gas to the heater. That is why when starting the pilot the gas control knob has to be pressed in long enough for the thermopile to heat up and start generating electricity. This current not only keeps the gas valve open but also provides electricity for the ON/OFF switch, remote control, or thermostat (see the illustration below). Because the thermopile generates the electricity needed to turn the heater on and off, this heater can be operated when the power is out (but the blower will not run).

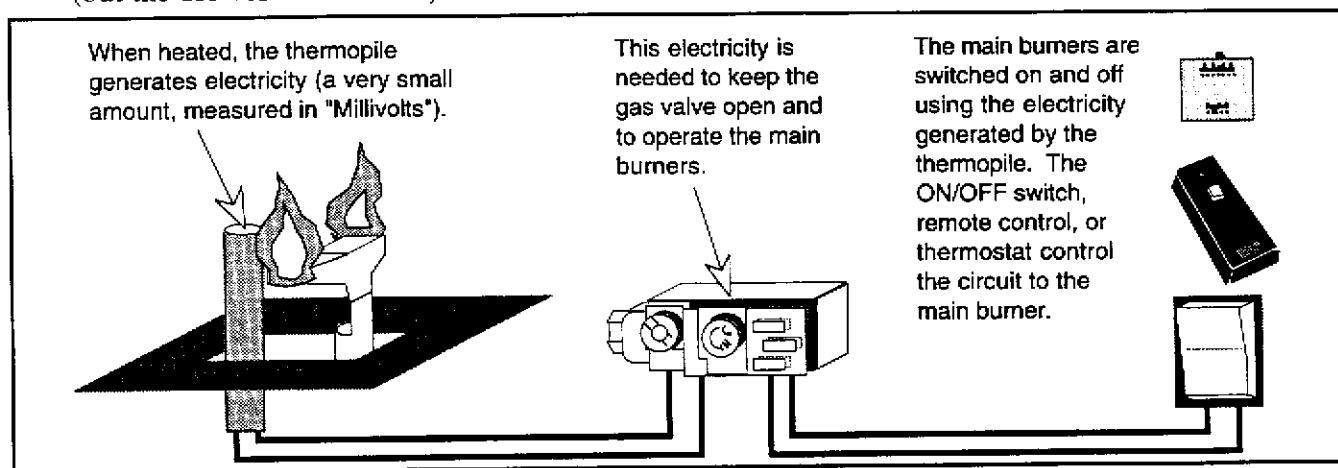

Why Nothing Should Be Placed Against the Heater

Your heater has a grill below the ashlip and convection air openings on the side and top that must not be blocked. The grill below the ashlip allows air into the firebox. If it is blocked the combustion inside the firebox will not burn normally. This will result in reduced efficiency and the exhaust gases will become dirty. The convection air openings on the side and top are used to draw room air over the hottest parts of the heater and distribute the warmed air into the room. If they are blocked, the heater will not heat as well and may become too hot internally.

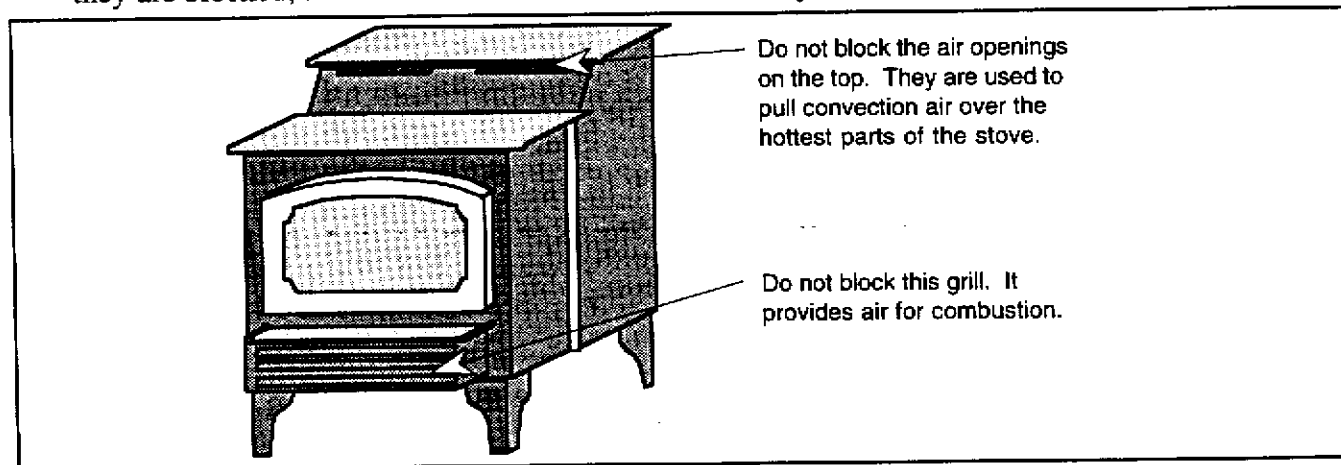

What Prevents Gas Buildup

Your heater has a high technology gas valve in combination with safety sensors which prevent any gas from building up. It also has a pilot light inside the firebox, which is a proven method for preventing gas buildup.

While the main burner is off

There is a thermopile directly next to the pilot light which can sense if the pilot is still lit. If the pilot goes out, this thermopile will no longer generate electricity which will cause the gas valve to automatically shut off all gas to the unit. This prevents the pilot light from spilling gas into the firebox.

While the main burner is on

The pilot light insures that the gas ignites inside the firebox, and that no gas builds up. In the unlikely case of the vent blocking, there is a sensor which will sense any backdrafts or overheating. This sensor will signal the gas valve to shut off all gas to the unit if the vent is blocked.

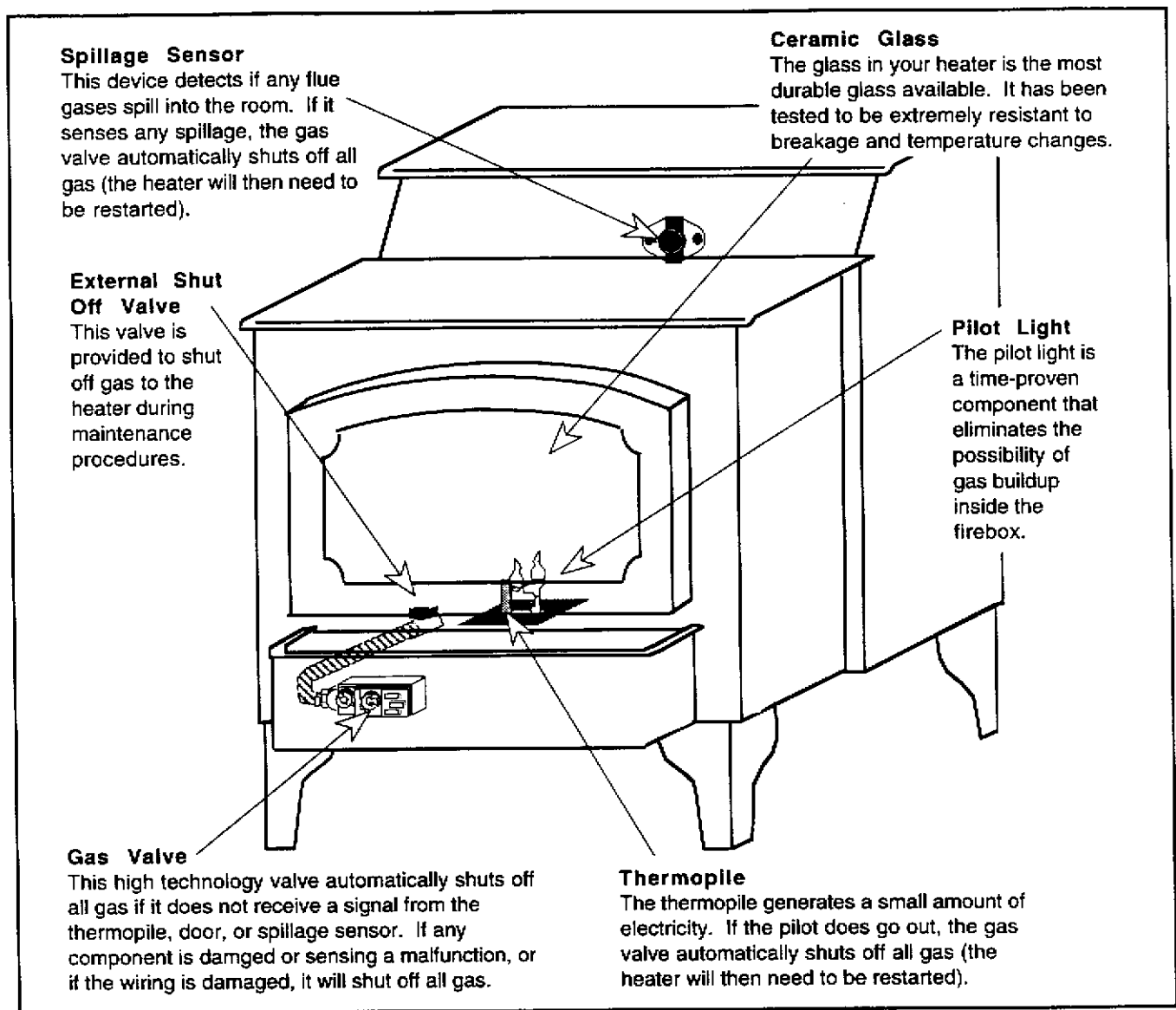

Wiring Diagram

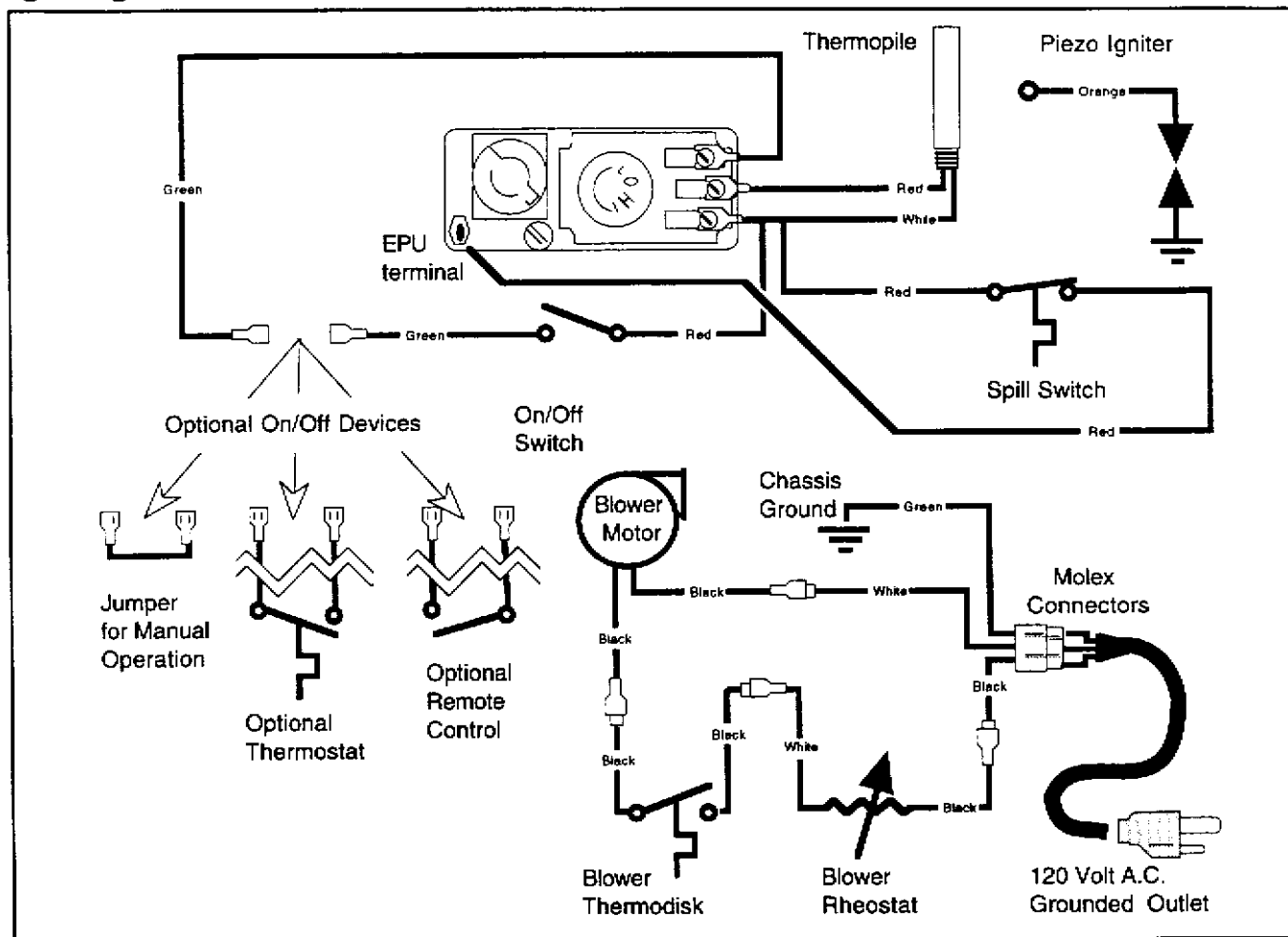

Replacement Parts

Replacement parts are available at your dealer. Contact Travis Industries for information on the closest dealer. The parts listed below are the only parts that the consumer may replace. All other parts must be replaced by a qualified gas service person.

Front ember strip, front and rear log	93-8000
Glass (includes gasket)	91-1491
Glass Gasket	90-1493
Brass Door (With handle, without glass)	99300201
Door Gasket	90-1511
Door Handle (Steel shaft with spring handle)	93-2001
Black Door (With handle, without glass)	99300200

TRAVIS INDUSTRIES, INC. warrants the LOPI 300-GS natural gas heater to be defect-free in material and workmanship for five (5) years from the date of purchase, with the exception of the electrical components, switches, piezo igniter, fans, gaskets, logs, moving parts, gas valve, manifold, and burner pan. This does not include service call cost or any other additional charges. Check with your dealer for all costs if arranging a warranty call. The exceptions listed are warranted for one (1) year from the date of purchase to be defect-free in material and workmanship.

Exclusions to this limited warranty include: Injury malfunction to the product, loss, damage, defect, failure to function due to accident, negligence, misuse, improper installation, alteration or adjustment of the manufacturers settings of components, lack of proper and regular maintenance, damage incurred while the unit is in transit, alteration, or act of God.

This limited warranty excludes damage caused by normal wear and tear, such as paint discoloration or chipping, worn or torn gasketing, logs, ember strip, etc. Also excluded is damage to the unit caused by abuse, improper installation, modification of the unit, drilling of the orifices, or the use of fuel other than natural gas.

TRAVIS INDUSTRIES, INC. is free of liability for any damages caused by the unit, as well as inconvenience expenses, material and labor charges incurred by the removal or reinstallation of any LOPI 300-GS unit. Incidental or consequential damages are not covered by this warranty. In some states, the exclusion of incidental or consequential damage may not apply.

This warranty does not cover any loss or damage incurred by the use or removal of any component or apparatus to or from the LOPI 300-GS unit without the express written permission of TRAVIS INDUSTRIES, INC. and bearing a TRAVIS INDUSTRIES, INC. label of approval.

Any statement or representation of LOPI 300-GS products and their performance contained in LOPI 300-GS advertising, packaging literature, or printed material is not part of this limited warranty.

This warranty is automatically voided if the unit's serial number has been removed or altered in any way.

Only the original purchaser of a LOPI 300-GS heater is covered by this warranty. If the unit is used for commercial purposes, it is excluded from this warranty.

No dealer, distributor, or similar person has the authority to represent or warrant LOPI 300-GS products beyond the terms contained within this warranty. TRAVIS INDUSTRIES, INC. assumes no liability for such warranties or representations.

THIS LIMITED WARRANTY IS THE ONLY WARRANTY SUPPLIED BY TRAVIS INDUSTRIES, INC., THE MANUFACTURER OF THE UNITS. ALL OTHER WARRANTIES, WHETHER EXPRESS OR IMPLIED, ARE HEREBY EXPRESSLY DISCLAIMED AND PURCHASER'S RECOURSE IS EXPRESSLY LIMITED TO THE WARRANTIES SET FORTH HEREIN.

This warranty is limited to the time frame set forth above. In some states, time limitations on warranties do not apply.

HOW TO USE YOUR LOPI 300-GS FIVE-YEAR WARRANTY: If you find your unit to be defective in workmanship or material within a 5-year period from the date of purchase contact your local authorized LOPI 300-GS dealer. If your dealer is unable to repair your unit's defect, he may process a warranty claim through TRAVIS INDUSTRIES, INC., including the name of the dealership where you purchased the unit, a copy of your receipt showing the date of the unit's purchase, and the serial number on your unit. At that time, you will be asked to ship your unit, freight charges prepaid, to TRAVIS INDUSTRIES, INC. TRAVIS INDUSTRIES, INC., at its option, will repair or replace, free of charge, your LOPI 300-GS unit if it is found to be defective in material or workmanship within the time frame stated within this limited warranty. TRAVIS INDUSTRIES, INC. will ship your unit, freight charges prepaid by TRAVIS INDUSTRIES, INC., to your regional distributor, or dealership.

To register your TRAVIS INDUSTRIES, INC. Five-Year Warranty, complete the enclosed warranty card and mail it within ten (10) days of the unit purchase date to: TRAVIS INDUSTRIES, INC., 10850 117th Place N.E., Kirkland, Washington 98033.

OTHER RIGHTS:

This warranty provides you with certain legal rights. You may have additional rights, which vary from state to state, in regards to this warranty.

Unit Serial Number _____

Date of Purchase _____

Dealer Name and Address _____

Complete and
save for your
records

Travis Industries, Inc. reserves the right to change, without notice, product features or specifications described.



Warnock Hersey



LOPI 300 GS

Listed Gas-Fired Vented Room Heater

WH-

Tested to ANSI Z21.11.1-1991 Gas-Fired Vented Room Heaters (Report # 6679 - Sept. 1993)
 Must be installed in accordance with all local codes, if any; if not, follow ANSI Z223.1
 and the requirements listed in the accompanying owner's manual.

This unit is equipped for use with NATURAL GAS ONLY.

Natural Gas Specifications:

Maximum Input Rating (BTU·Hr).....31,000
 Minimum Input Rating (BTU·Hr)18,000
 Front Burner Orifice (DMS).....#53
 Rear Burner Orifice (DMS).....#43

Pressure Specifications:

Manifold Pressure HI Setting (in W.C. kPa).....3.5 .87
 Manifold Pressure LO Setting (in W.C. kPa)1.0 .25
 Minimum Inlet Pressure (in W.C. kPa)5.5 1.37

Minimum Clearance to Combustibles

Unit to Sidewall10"
 Unit to Backwall3"
 Unit to Cornerwall4"
 Alcove Minimum Width.....44"
 Alcove Minimum Height58"
 Alcove Maximum Depth.....45"
 Mantle Height Above Unit.....17"
 Front of Unit.....36"

Minimum Floor Protection

At least .018" thick underneath the unit.

Blower Electrical Rating: 115 Volts, 1.5 Amps, 60 Hz.

FAN TYPE VENTED CIRCULATOR

WARNING:

Operation of this heater when not connected to a properly installed and maintained venting system or tampering with the vent safety shutoff system can result in carbon monoxide (CO) poisoning and possible death.

Improper installation, adjustment, alteration, service or maintenance can cause injury or property damage. Refer to the information in the owner's manual provided with this appliance. For assistance or additional information consult a qualified installer, service agency or the gas supplier.

Risk of electrical shock. Disconnect power before servicing unit.

Manufacture Date: 1994 Jan. May Sep.
 1995 Feb. Jun. Oct.
 1996 Mar. Jul. Nov.
 1997 Apr. Aug. Dec.



Travis Industries, Inc.
 10650 117th Pl. N.E. Kirkland, WA 98033

DO NOT REMOVE THIS LABEL

MADE IN U.S.A.

Stove Legs

There are three different stove legs available for your gas heater: cast brass; cast black; and, black steel. The instructions for installing the legs are the same for each type of leg.

Raise the stove by inserting some pieces of lumber in the middle of the stove to a height of about 8". Line up the hole in the top of the leg with the threaded bolt hole in each corner of the stove bottom. Using a 9/16" open end or socket wrench, fasten the leg to the stove with the supplied attachment bolts and washers, making sure the legs are flush with the corners of the stove.

Unscrew the leveling bolts enough so the stove will rest on the upper tips, not the metal portion of the legs. Lower the stove down.

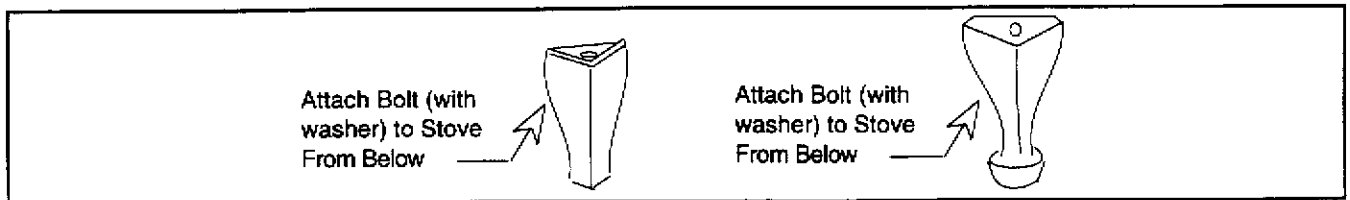

To level the stove, lift the stove up and unscrew each leveling bolt the appropriate amount. The rubber tips of the leveling bolts will tear if they are adjusted while weight is applied to them.

Pedestal

NOTE: Use the Lopi pedestal with part number 99200101.

Unpack the box containing the pedestal and check for any damage. Report any damage to your dealer.

Place the pedestal in place and lift the stove on top of it. Line up the threaded bolt holes in the bottom of the stove with the two holes on the tabs on the inside edge of the pedestal (see the illustration below). Using a 9/16" socket wrench, fasten the pedestal to the stove with the supplied bolts and washers.

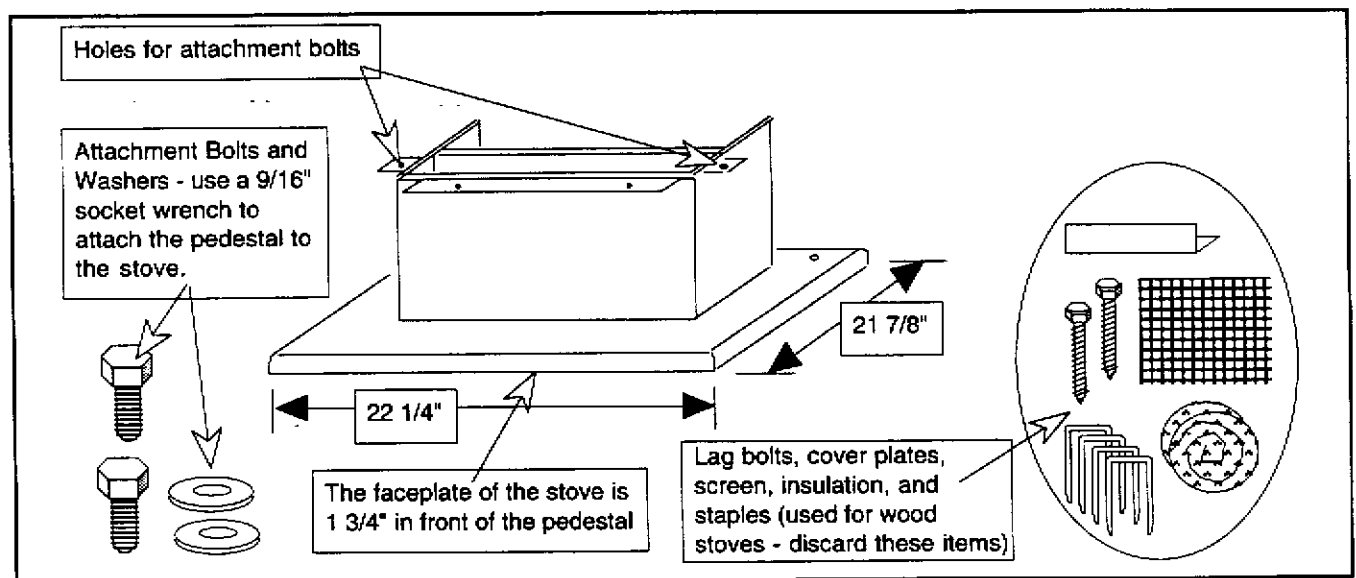

Optional Remote Control

The remote control allows remote operation of the main burner. Follow the directions below to install.

1. With the gas shut off and the heater unplugged, remove the ashlip control housing by unscrewing the three attachment screws with a 7/16" nutdriver. Carefully lay the ashlip control housing face down in front of the heater.

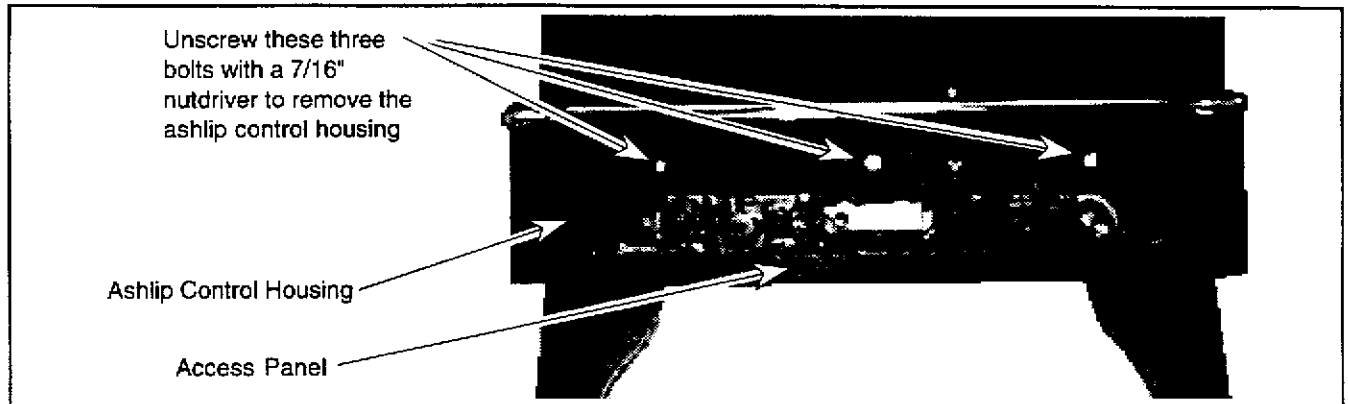

2. Locate the 2" long green jumper wire. It can be found near the on/off switch. Remove the jumper wire from the two green wires it attaches to (one leading to the on/off switch, the other to the gas control valve).
3. The remote control receiver wire enters the ashlip control housing in the same location the power cord does. Use a pair of slip joint pliers to remove the strain relief that holds the power cord in place (see the illustration below). Unwind the remote control receiver wire and route the end with quick connects through strain relief and to a location near the on/off switch. Insert the strain relief back in the hole until it snaps into place.

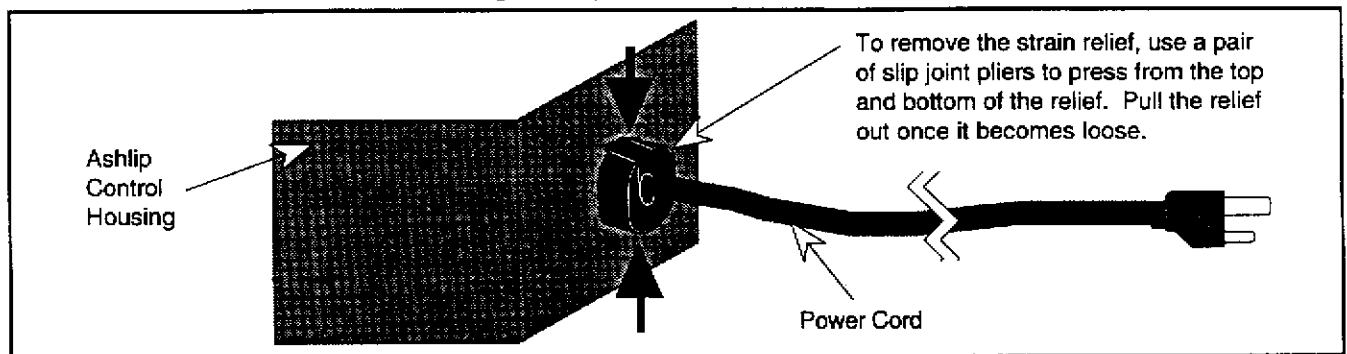

4. Attach the thermostat wire to the two green wires that were detached in step 2. Make sure to route the remote control receiver wire through the notch in the ashlip control housing partition if it entered through the center or left side (see the illustration below).

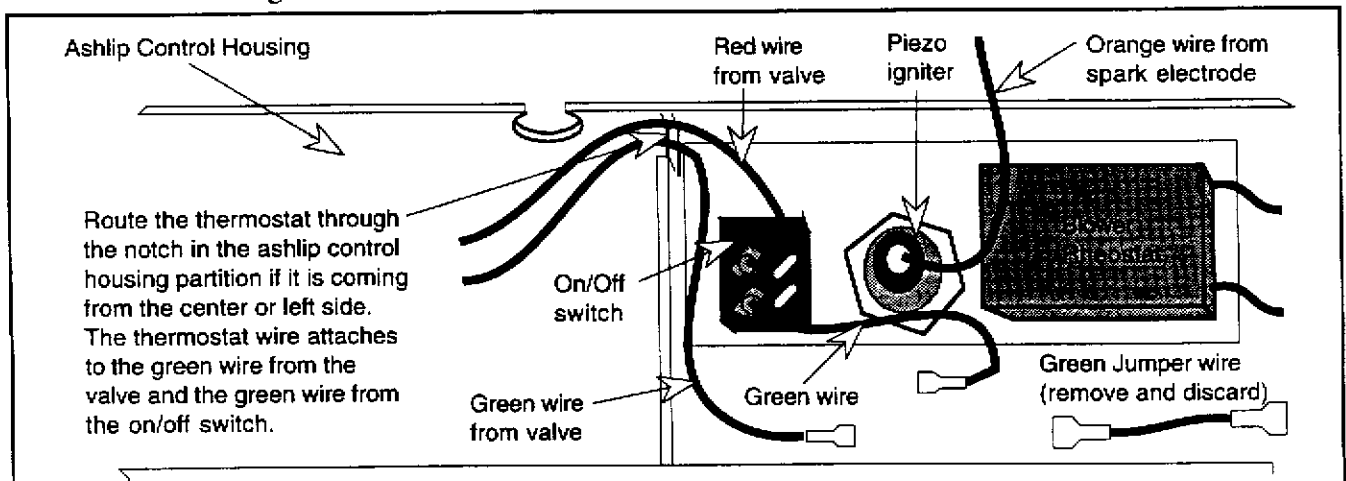

Optional Remote Control (continued)

5. Replace the ashlip control housing. Make sure none of the wiring is pinched. Determine the location of the remote control receiver. Find a location that is within reach of 10' of wire. Route the remote control receiver wire to the location and connect it to the remote control receiver by attaching the quick connects (the orientation of the wires does not matter).
6. Place a nine volt battery inside the remote control receiver and remote control (see the illustration below).

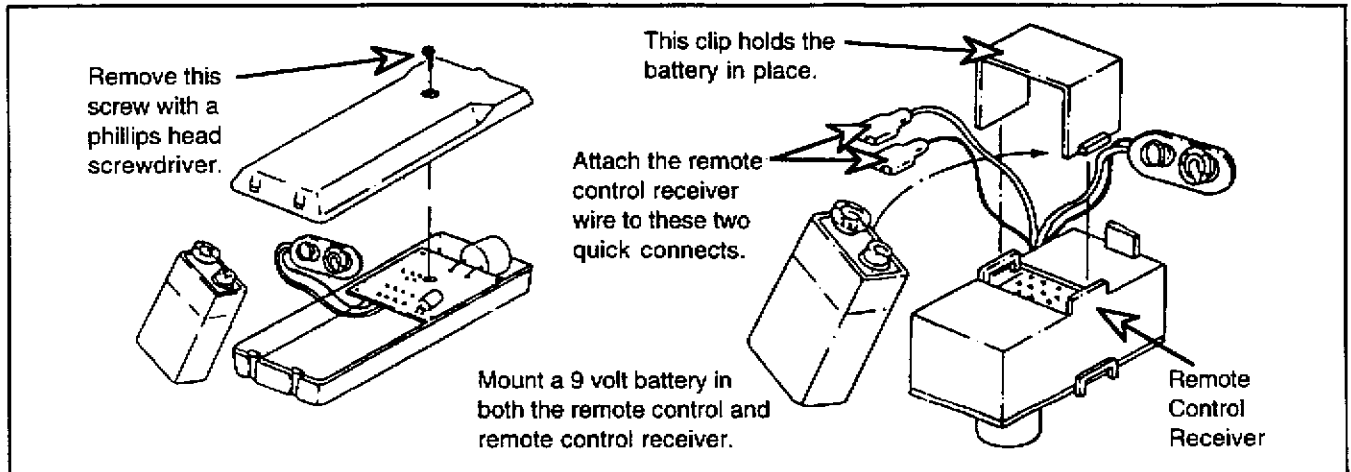

7. Mount the remote control receiver to the wall using two screws (not included). The screws pass through the cover plate and hold the remote control receiver in place.

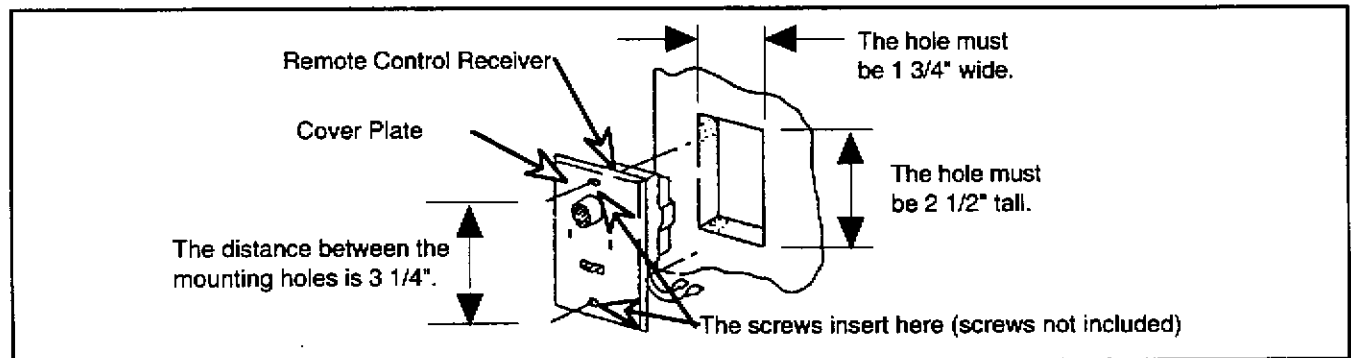

8. Test the remote control's operation prior to leaving the installation. Start the pilot, let it run five minutes, then turn the on/off switch on the heater to "ON". Switch the remote control receiver to "REMOTE". Press the remote control for one second to turn the heater on and off. If it does not, check all of the electrical connections and re-test. When the remote control receiver is turned to "ON" the heater will stay on, when on "OFF" the heater will stay off, regardless of the remote control.

Optional Thermostat

The thermostat allows the main burner to turn on and off automatically for consistent room temperature. Follow the directions below to install.

1. With the gas shut off and the heater unplugged, remove the ashlip control housing by unscrewing the three attachment screws with a 7/16" nutdriver. Carefully lay the ashlip control housing face down in front of the heater.

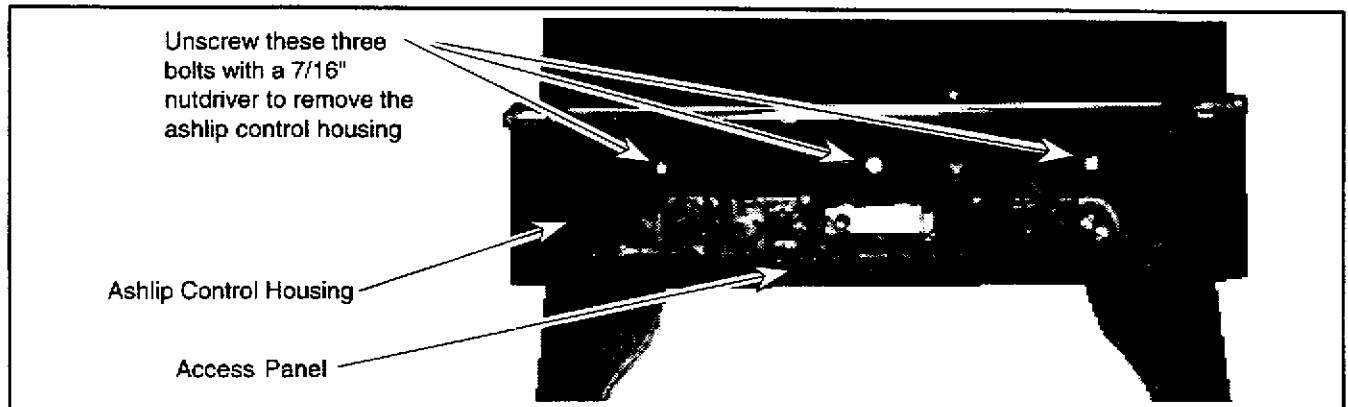

2. Locate the 2" long green jumper wire. It can be found near the on/off switch. Remove the jumper wire from the two green wires it attaches to (one leading to the on/off switch, the other to the gas control valve - see the illustration on the following page).
3. The thermostat wire enters the ashlip control housing in the same location the power cord does. Use a pair of slip joint pliers to remove the strain relief that holds the power cord in place (see the illustration below). Unwind the thermostat wire and route the end with quick connects through the strain relief and to a location near the on/off switch. Insert the strain relief back in the hole until it snaps into place.

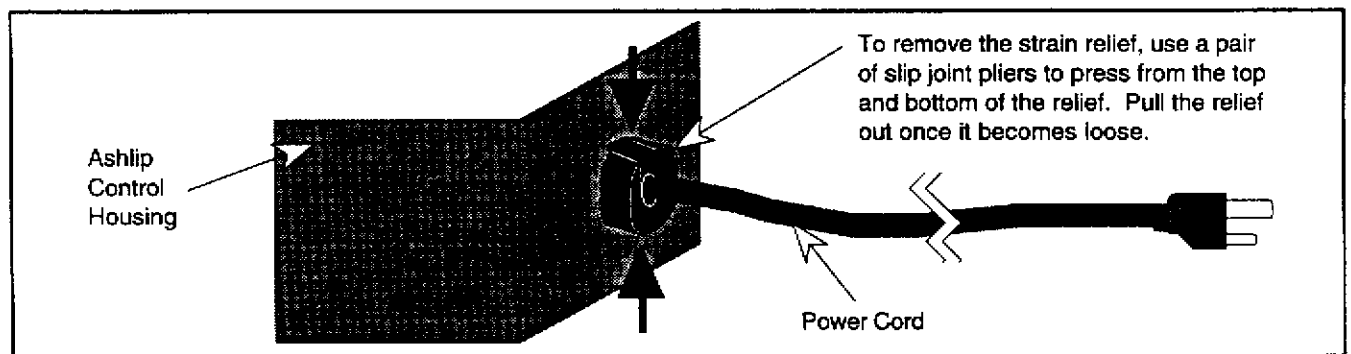

4. Attach the thermostat wire to the two green wires that were detached in step 2. Make sure to route the thermostat wire through the notch in the ashlip control housing partition if it entered through the center or left side.

Optional Thermostat (continued)

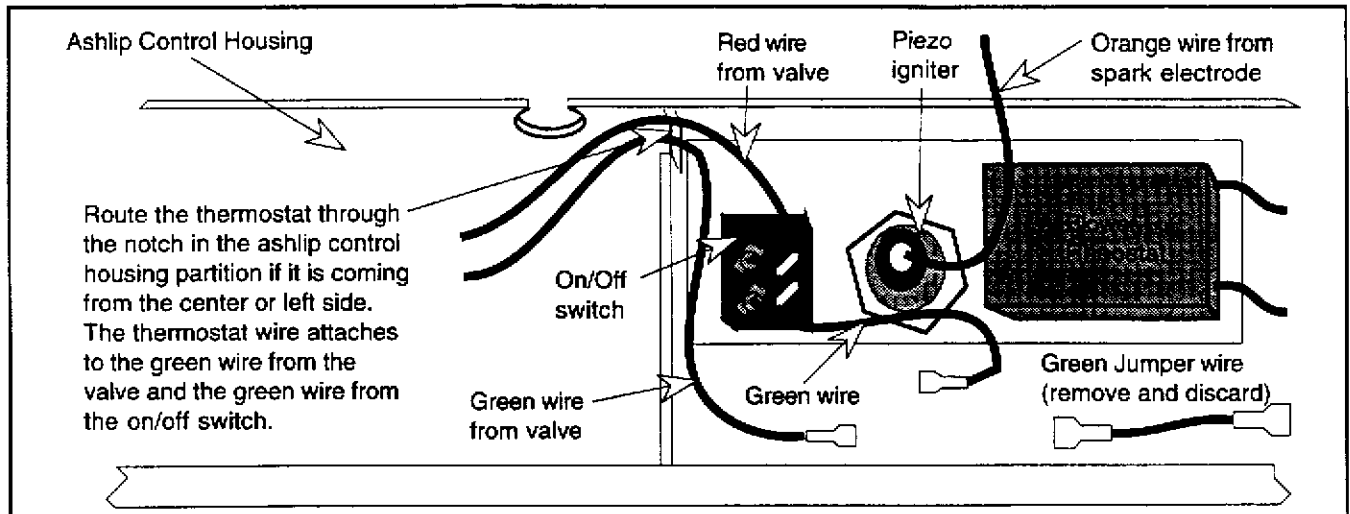

5. Replace the ashlip control housing. Make sure none of the wiring is pinched.
6. Determine the location of the thermostat. Find a location that is centralized in the room and within reach of 50' of wire. Route the thermostat wire to the location and attach the thermostat wire to the thermostat. Cut off any excess length of wire and expose approximately 1/2" of wire for connection to the thermostat. Attach the thermostat wire to the two clips on the thermostat using a standard screwdriver. Make sure the wire makes a good electrical contact.

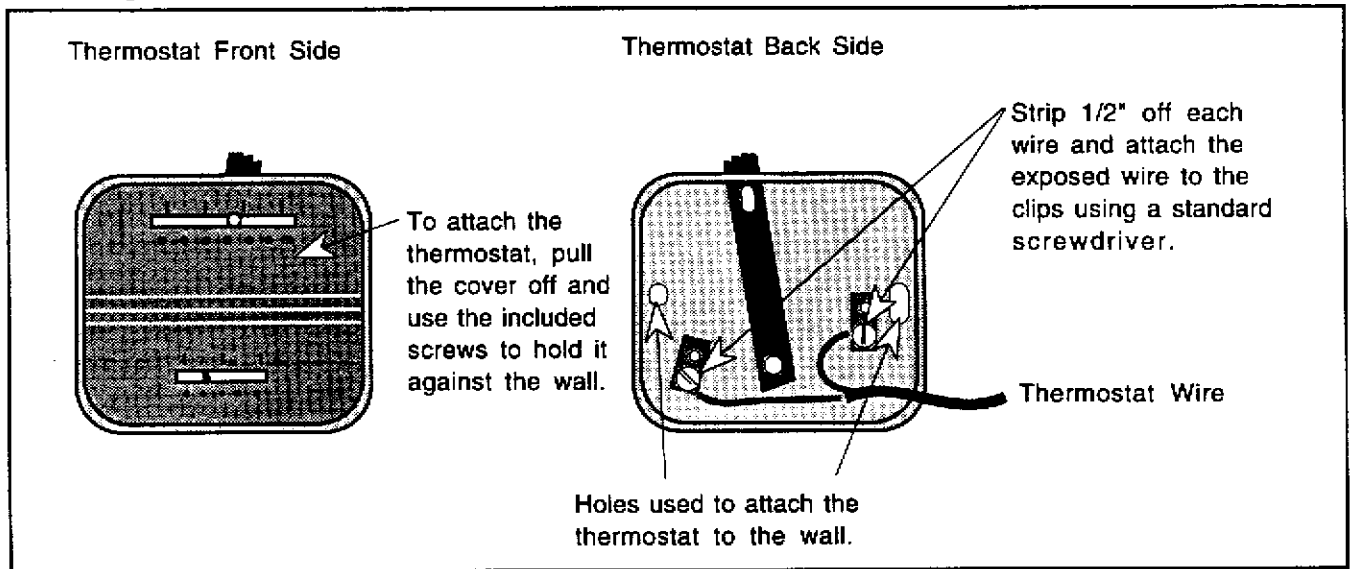

7. Remove the cover of the thermostat by pulling it apart carefully. The thermostat has mounting holes on each side of its base. Use the included screws to attach the thermostat to the wall. Tuck any excess wire behind the thermostat and replace the thermostat cover.
8. Test the thermostat's operation prior to leaving the installation. Turn the thermostat to its highest position (all the way to the right). Start the pilot, let it run five minutes, then turn the on/off switch on. The heater should turn on. If it does not, check all of the electrical connections and re-test. The thermostat should turn the heater on when turned to its highest position, and turn off when turned to its lowest position. **NOTE:** if the temperature in the room is not between 50° and 90° this will not work because of the thermostat's range. Wait until a suitable temperature is achieved in the room before testing the thermostat.

Re-Routing the Power Cord to the Left or Rear of the Heater

The power cord is normally routed to the right side of the heater. It may be re-routed to the left or rear of the stove. The directions below detail this procedure.

1. TURN THE GAS LINE VALVE TO OFF AND UNPLUG THE HEATER (if the heater is connected or plugged in).
2. Use slip joint pliers to remove the strain relief that holds the power cord in place (see the illustration below).

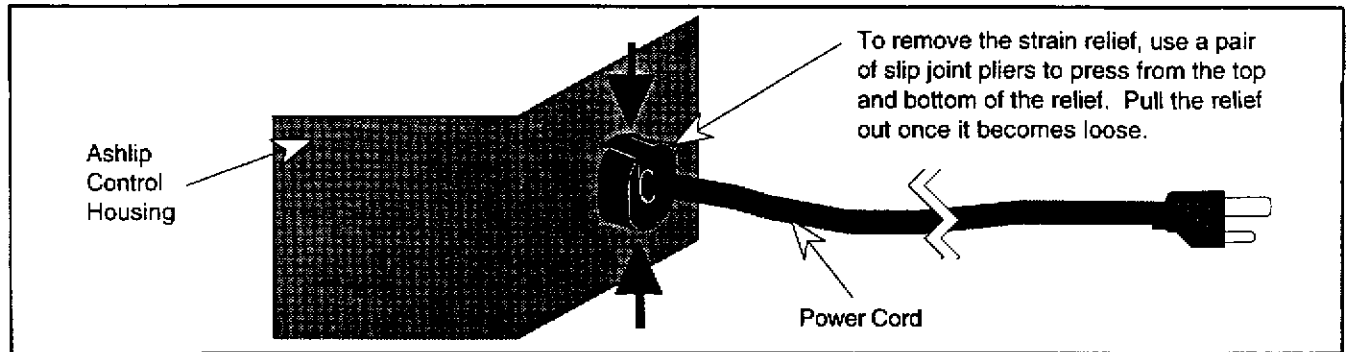

3. Open the access panel and with a 7/16" nutdriver loosen the three bolts that hold the control housing in place. When the control housing becomes loose, lift it off the bolts and place it face down in front of the heater. The wires that lead to the control housing can then be accessed.

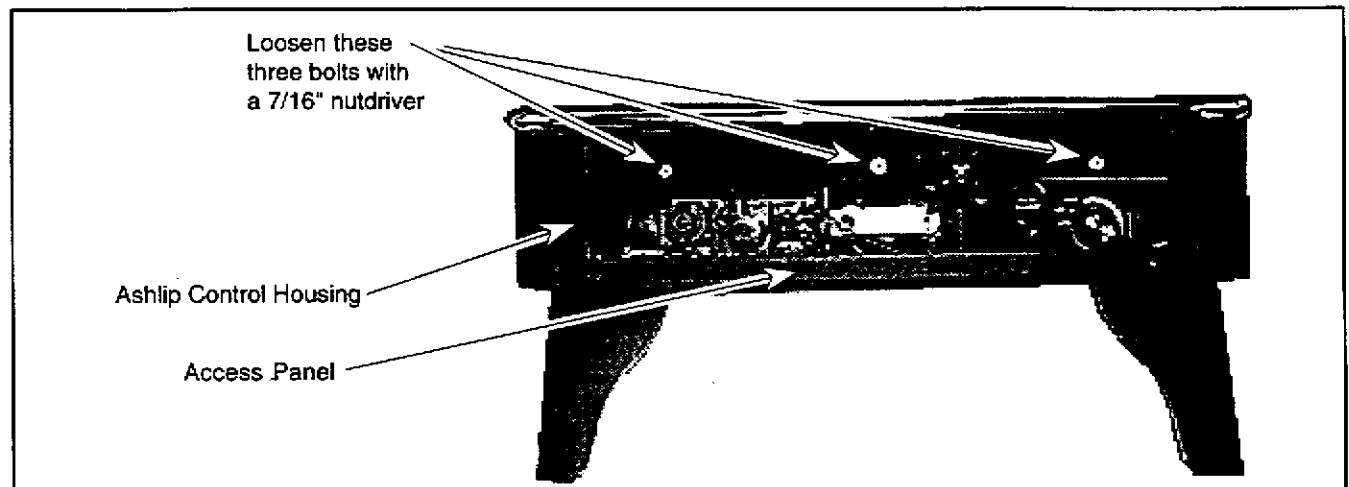

4. Disconnect the molex connector that attaches to the power cord. Remove the power cord from the heater by threading the molex plug through the hole in the ashlip control housing (see the illustration below). To route the power cord to the left side, follow step 5A. To route the cord to the rear (stoves only), follow step 5B.

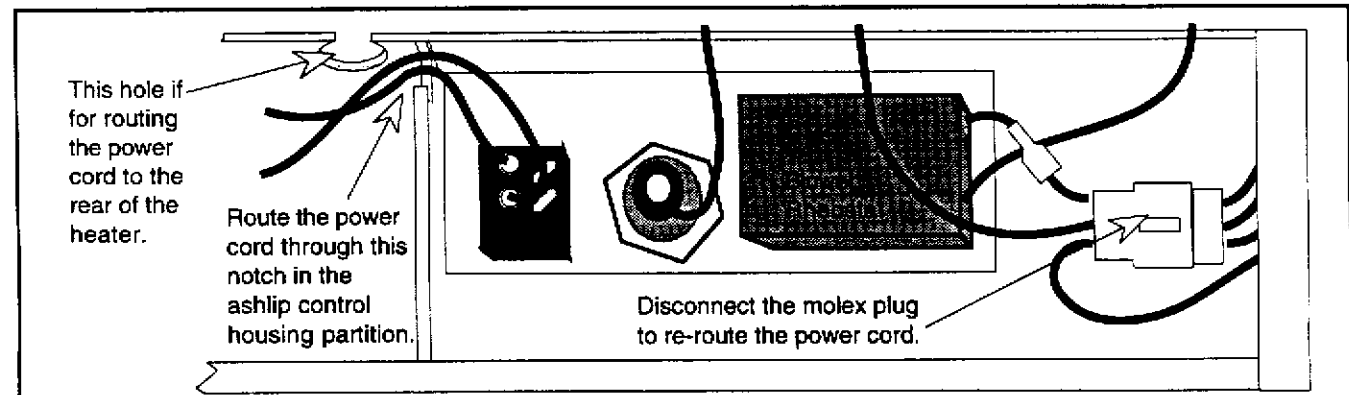

Re-Routing the Power Cord to the Left or Rear of the Heater (Continued)

5A Pry the button plug from the left side of the ashlip control housing using a screwdriver (see the illustration below). Insert it in the hole on the right side where the strain relief was removed. Insert the power cord through the hole on the left side. Route the power cord through the notch in the ashlip control housing partition and re-connect the power cord by connecting the molex plugs (see the illustration on the previous page). Place the strain relief over the power cord next to the ashlip control housing. Compress the strain relief by clamping it with a pair of slip nose pliers. Then insert it into the ashlip control housing until it locks into place.

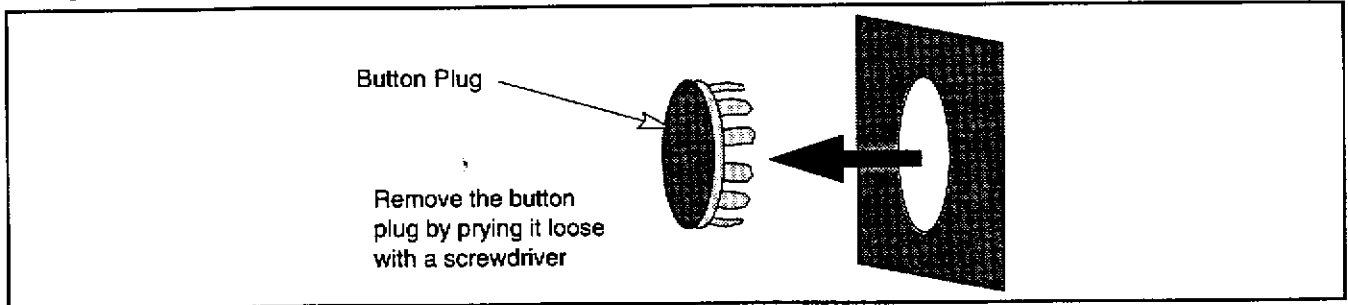

5B Included in the accessory pack are three cord mounts and a button plug. Insert the button plug in the hole on the right where the strain relief was removed. Insert the power cord through the hole on the bottom of the ashlip control housing. Route the power cord through the notch in the ashlip control housing partition and re-connect the power cord by connecting the molex plugs (see the illustration on the previous page). Place the strain relief over the power cord next to the ashlip control housing. Compress the strain relief by clamping it with a pair of slip nose pliers. Then insert it into the ashlip control housing until it locks into place. The cord is hidden under the heater with the use of cord mounts inserted into the baseplate of the heater. Insert the three cord mounts into the base of the heater (see the illustration below for details). Then insert the power cord into each cord mount until it latches in place. After installation, pull the slack out of the power cord.

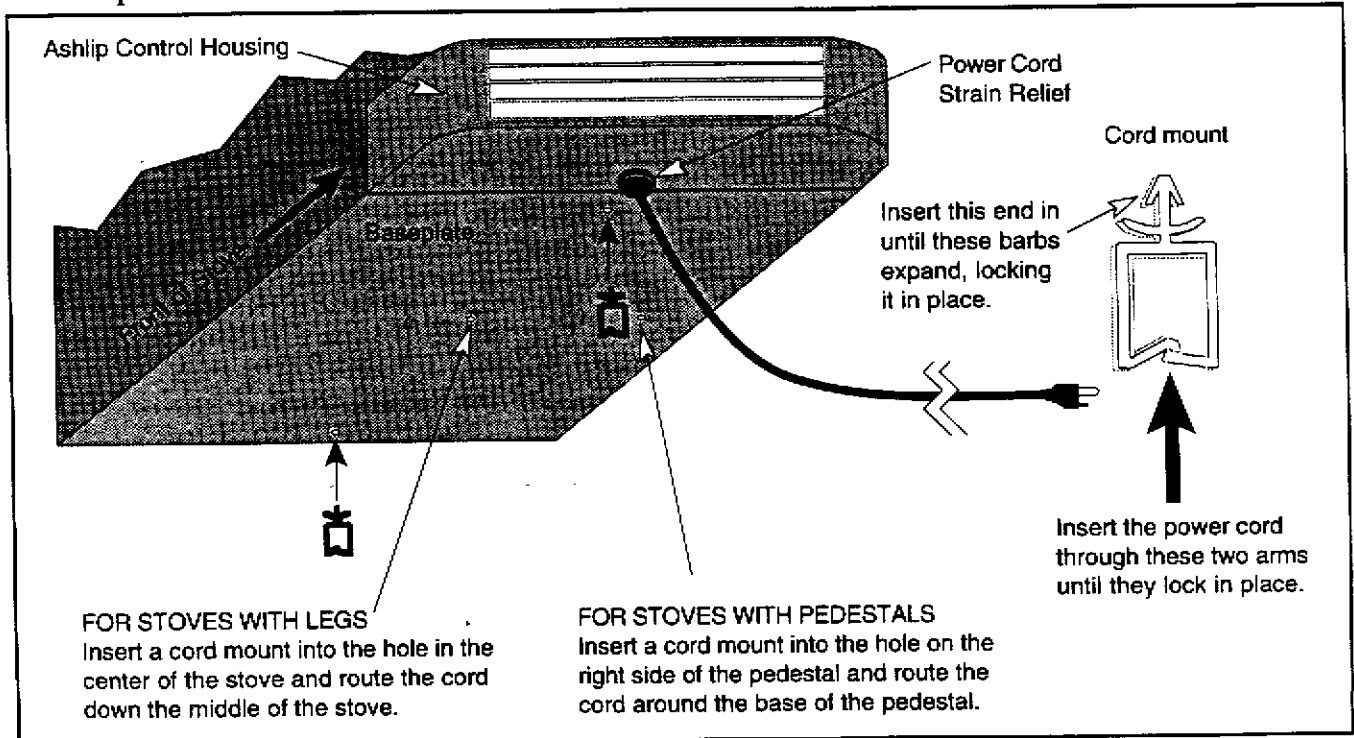

6. Replace the ashlip control housing, making sure no wiring becomes pinched, and tighten the three bolts that hold it in place.