



· 864 See Through (ST) · GreenSmart™ 2 Fireplace

- Operation
- Maintenance

Tested and Listed by



OMNI-Test Laboratories,
Inc.
Portland, Oregon
Report # 028-F-80c-5
ANSI Z21.88a-2003

WARNING: If the information in these instructions is not followed exactly, a fire or explosion may result causing property damage, personal injury or loss of life.

- Do not store or use gasoline or other flammable vapors and liquids in the vicinity of this or any other appliance.

WHAT TO DO IF YOU SMELL GAS

- Do not try to light any appliance.
- Do not touch any electrical switch; do not use any phone in your building.
- Immediately call gas supplier from a neighbor's phone. Follow the gas supplier's instructions.
- If you cannot reach your gas supplier, call the fire department.
- Installation and service must be performed by a qualified installer, service agency or the gas supplier.

This appliance may be installed in an aftermarket permanently located, manufactured home (USA only) or mobile home, where not prohibited by local codes.

This appliance is only for use with the type(s) of gas indicated on the rating plate. A conversion kit is supplied with the appliance.

WARNING



**HOT GLASS WILL
CAUSE BURNS.
DO NOT TOUCH GLASS
UNTIL COOLED.
NEVER ALLOW CHILDREN
TO TOUCH GLASS.**

Owner's Manual



**TRAVIS INDUSTRIES
HOUSE OF FIRE**

www.travisproducts.com

© Copyright 2012, T.I.

\$10.00

100-01304

4121105

4800 Harbour Pointe Blvd. SW
Mukilteo, WA 98275

Introduction

We welcome you as a new owner of an 864 See Through (ST) gas fireplace. This manual details operation and maintenance of this fireplace. Please familiarize yourself with the Owner's Manual before operating your heater and save the manual for future reference.

Important Information

No other 864 ST gas fireplace has the same serial number as yours. The serial number is on the listing label that is chained to the gas control valve. This serial number may be needed in case you require service.

Model: 864 ST GS2 Fireplace

Serial Number: _____

Purchase Date: _____

Purchased From: _____

Register your warranty online at:

traviswarranty.com

Or, mail your warranty card to:

Travis Industries House of Fire
4800 Harbour Pointe Blvd. SW
Mukilteo, WA 98275

Save Your Bill of Sale.

To receive full warranty coverage, you will need to show evidence of the date you purchased your heater. Do not mail your Bill of Sale to us.

We suggest that you attach your Bill of Sale to this page so that you will have all the information you need in one place should the need for service or information occur.

Installation Warnings

- **Installation requirements are printed in the 864 ST GS2 Installation Manual (part # 100-01304). All requirements in the installation manual must be met.**
- **Failure to follow all of the requirements may result in property damage, bodily injury, or even death.**
- **This heater must be installed by a qualified installer who has gone through a training program for the installation of direct vent gas appliances.**
- **This appliance must be installed in accordance with all local codes, if any; if not, follow ANSI Z223.1 and NFPA 54(88).**
- **In Manufactured or Mobile Homes must conform with Manufactured Home Construction and Safety Standard, Title 24 CFR, Part 3280, or, when such a standard is not applicable, the Standard for Manufactured Home Installations, ANSI/NCSCS A225.1. This appliance may be installed in Manufactured Housing only after the home is site located.**
- **The fireplace is designed to operate on natural gas, or propane (LP).**
- **All exhaust gases must be vented outside the structure of the living-area. Combustion air is drawn from outside the living-area structure.**
- **Notify your insurance company before hooking up this fireplace.**

Table of Contents

Introduction	2	Glass Frame Removal and Installation (continued)	16
Important Information.....	2	Log Set Installation	17
Installation Warnings.....	2	Logs in Place – FRONT SIDE (gas control valve side)	17
Table of Contents.....	3	Logs in Place – BACK SIDE.....	17
Features.....	3	Center Log Installation	18
Heating Specifications	3	Front Left Log.....	19
Before You Begin.....	6	Front Left Upper Log	20
Location of Controls.....	6	Front Upper Center Log	21
Starting the Fireplace for the First Time	7	Back Left Log	22
Turning the Fireplace On and Off	7	Right Ember Chunk.....	23
Comfort Control	7	Back Ember Chunk	23
Adjusting the Flame Height.....	8	Back Left Log	24
Accent Light.....	8	Back Upper Right Log	25
Adjusting the Optional Blower Speed.....	9	Ember Placement.....	26
Continuous Pilot / GreenSmart™ Pilot Switch ...	9	Rock Wool Placement	26
Normal Operating Sounds.....	10	Glass Cleaning	27
Normal Operating Odors	10	Troubleshooting Table	28
Maintaining Your Fireplace's Appearance	11	Wiring Diagram	29
Battery Replacement	11	GS2 Remote Wiring Diagram.....	30
Power Backup Batteries	11	Replacement Parts List	30
Control Panel Light Battery	11	CONDITIONS & EXCLUSIONS.....	31
Accent Light Replacement.....	12	IF WARRANTY SERVICE IS NEEDED:.....	31
Yearly Service Procedure.....	12	Accessories.....	32
Grill Installation and Removal.....	13	GreenSmart™ Remote / Thermostat.....	32
Face Installation and Removal.....	14	Blower	32
Glass Frame Removal and Installation	15	Firebacks.....	32
		Index	34

Features

- Works During Power Outages (battery backup)
- Optional GreenSmart™ Thermostat / Remote Control
- Realistic "Wood Fire" Look
- Optional Blower for Effective Heat Distribution
- Built-In Accent Light (night light)
- Built-In Control Panel Light
- Standing or Intermittent (GreenSmart) Pilot
- Convenient Operating Controls
- Variable-Rate Heat Output
- Low Maintenance

Heating Specifications

	Natural Gas	Propane
Approximate Heating Capacity (in square feet)*	Up to 1,500 (139 sq. M)	Up to 1,500 (139 sq. M)
Maximum BTU Input Per Hour	37,500 (39.5 MJ)	37,500 (39.5 MJ)

* Heating capacity will vary with floor plan, insulation, and outside temperature.

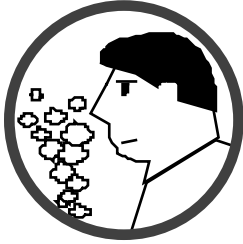

IF YOU SMELL GAS:

- * Do not light any appliance
- * Extinguish any open flame
- * Do not touch any electrical switch or plug or unplug anything
- * Open windows and vacate building
- * Call gas supplier from neighbor's house, if not reached, call fire department



This unit must be installed by a qualified installer to prevent the possibility of an explosion. Your dealer will know the requirements in your area and can inform you of those people considered qualified. The room heater should be inspected and cleaned before use and at least annually by a qualified service person. More frequent cleaning may be required due to excessive lint from carpeting, bedding material, etc.

The instructions in this manual must be strictly adhered to. Do not use makeshift methods or compromise in the installation. Improper installation will void the warranty and safety listing.

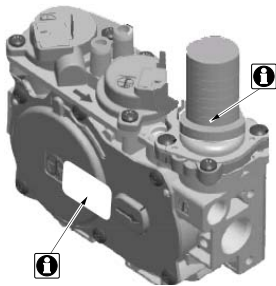

This heater is either approved for natural gas (NG) or for propane (LP). Burning the incorrect fuel will void the warranty and safety listing and may cause an extreme safety hazard. Direct questions about the type of fuel used to your dealer. Check for a label on the flame adjust knob on the gas control valve (this is the best place to check). You may also check for a label on the gas control valve body.



Contact your local building officials to obtain a permit and information on any installation restrictions or inspection requirements in your area. Notify your insurance company of this heater as well.



If the flame becomes sooty, dark orange in color, or extremely tall, do not operate the heater. Call your dealer and arrange for proper servicing.

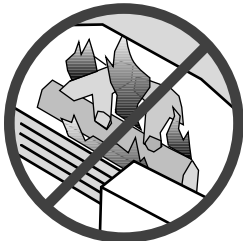

It is imperative that control compartments, screens, or circulating air passageways of the heater be kept clean and free of obstructions. These areas provide the air necessary for safe operation.



Do not operate the heater if it is not operating properly in any fashion or if you are uncertain. Call your dealer for a full explanation of your heater and what to expect.



Do not store or use gasoline or other flammable liquids in the vicinity of this heater.



Do not operate if any portion of the heater was submerged in water or if any corrosion occurs. Immediately call a qualified service technician to inspect the appliance and to replace any part of the control system and any gas control that has been under water.



Do not place clothing or other flammable items on or near the heater. Because this heater can be controlled by a thermostat there is a possibility of the heater turning on and igniting any items placed on or near it.

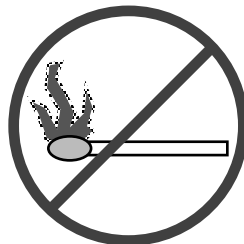

Light the heater using the built-in igniter. Do not use matches or any other external device to light your heater.



The viewing glass should be opened only for conducting service. Do not operate with cracked, broken, or removed glass.

Any safety screen or guard removed for servicing must be replaced prior to operating the heater.

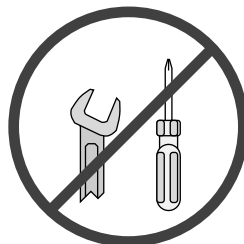

Never remove, replace, modify or substitute any part of the heater unless instructions are given in this manual. All other work must be done by a trained technician. Don't modify or replace orifices.



Operate the heater according to the instructions included in this manual.

If the main burners do not start correctly turn the gas off at the gas control valve and call your dealer for service.

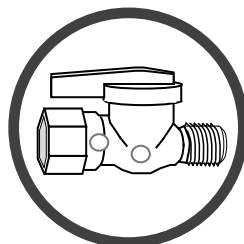

Instruct everyone in the house how to shut gas off to the appliance and at the gas main shutoff valve. The gas main shutoff valve is usually next to the gas meter or propane tank and requires a wrench to shut off.



This unit is not for use with solid fuel

Do not place anything inside the firebox (except the included fiber logs).

If the fiber logs become damaged, replace with Travis Industries log set.



Do not throw this manual away. This manual has important operating and maintenance instructions that you will need at a later time. Always follow the instructions in this manual.



Children and adults should be alerted to the hazards of high surface temperature and should stay away to avoid burns or clothing ignition. Young children should be supervised when they are in the same room as the heater.



Travis Industries, Inc. grants no warranty, implied or stated, for the installation or maintenance of your heater, and assumes no responsibility of any consequential damage(s).

Before You Begin

- Read this entire manual before you use your new fireplace (especially the section "Safety Precautions" on pages 4 & 5). Failure to follow the instructions may result in property damage, bodily injury, or even death.

Location of Controls

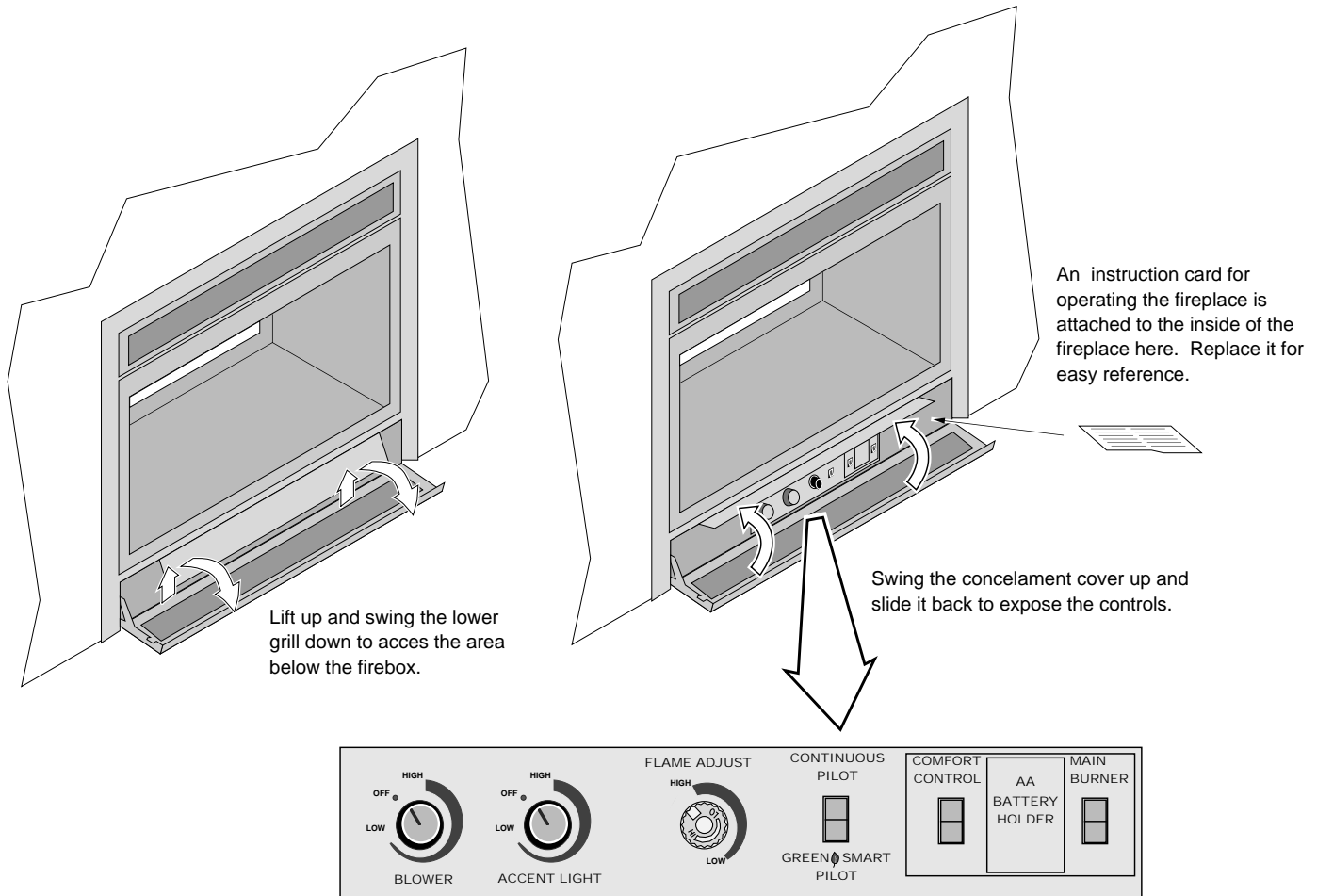

Optional Blower Control	This knob controls the speed of the optional internal convection blower that pushes heated air into the room.
Accent Light	This knob controls the accent lights located behind the logs.
Flame Adjust Knob	This knob controls the flame height from low ("LO") to high ("HI").
Continuous Pilot -- GreenSmart Pilot	This switch controls how the pilot flame works. See the section "Continuous Pilot / GreenSmart Pilot" for details.
Comfort Control	This switch turns the rear burner on and off.
AA Battery Holder	This holder contains 4 AA batteries that allow the fireplace to operate during power outages.
Main Burner	This switch turns the fireplace burners on and off.

Starting the Fireplace for the First Time

- Burn the heater at a high setting with the blower off for an extended period (up to 48 hours). This will cure the painted surfaces. **Fumes** from the paint curing and oil burning off the steel will occur. This is normal. We recommend opening a window to vent the room.
- **Condensation** may appear on the glass each time you start the fireplace - this is normal.
- **Blue Flames** will occur on the fireplace when it first comes on. After fifteen minutes the flames will turn a more realistic yellow and orange color.
- Certain installations use a remote, thermostat, or wall switch to turn the fireplace on and off. If this is the case, leave the ON/OFF switch "ON".
- Verify the power backup and control light batteries are installed (see page 11).

Turning the Fireplace On and Off

Use the main burner switch to turn the main burner on and off.

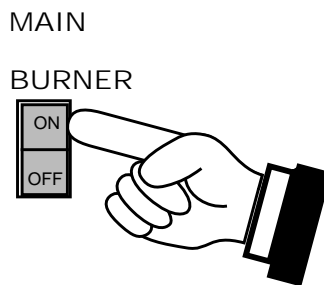

NOTE FOR REMOTES, THERMOSTATS, OR WALL SWITCHES:

The on/off switch on the fireplace may be required to be left in the ON or OFF position for the fireplace to operate. Consult your installer or dealer for details.

- Do not place any combustible items on top of or directly in front of the fireplace, even temporarily. An optional thermostat may start the fireplace causing a combustible item to ignite.
- If the fireplace turns on and off frequently while using the thermostat, you may want to adjust the flame height down until it produces just enough heat needed.

Comfort Control

The rear portion of the burner may be shut off to lower the heat output and flame size from the burner (this is called the comfort control). Use the comfort control switch to adjust this as desired.

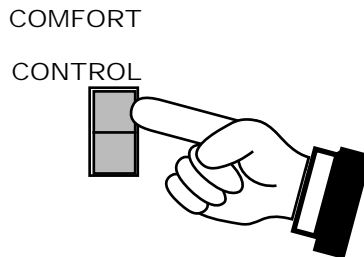

Adjusting the Flame Height

This fireplace has an adjustable flame to tailor the look and heat output to your specific needs. It is adjusted by turning the flame adjust knob.

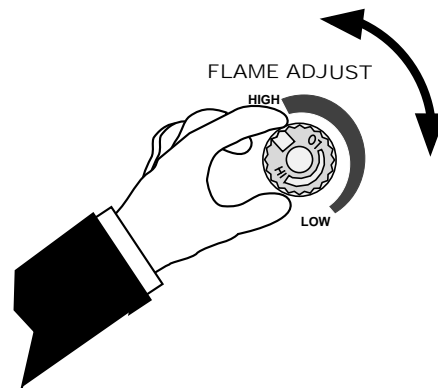

Accent Light

This fireplace has a built-in accent light that may be turned on and off and dimmed to your preference. Turn the knob to achieve the desired light output.

NOTE FOR STAINLESS OR ENAMEL FIREBACKS

Because stainless or enamel firebacks are reflective, they may create unwanted glare or "lines" if the accent light is turned to HIGH. We recommend keeping the accent light at a low level with these unique firebacks.

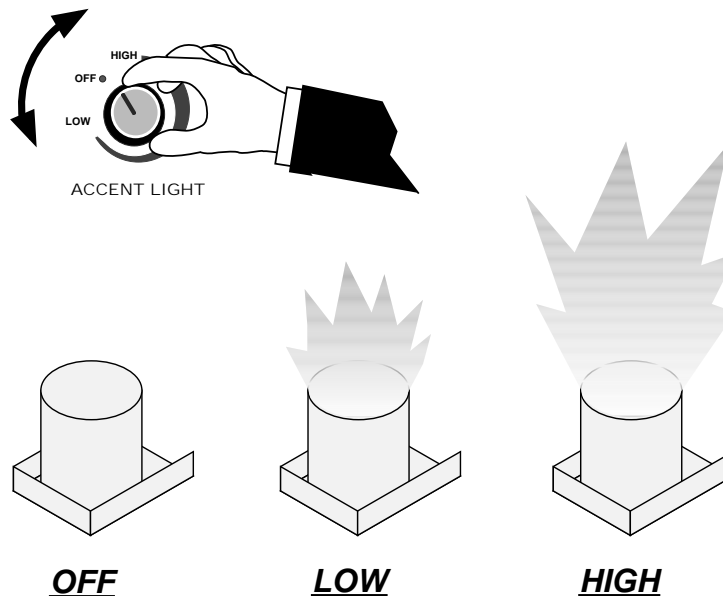

Adjusting the Optional Blower Speed

The blower helps transfer heat from the heater into the room. It will not turn on until the heater is up to temperature (approximately 15 minutes after starting). See the illustration below for instructions on adjusting the blower speed.

NOTE: With the rear burner off (comfort control), the heater may not become hot enough for the blower to turn on.

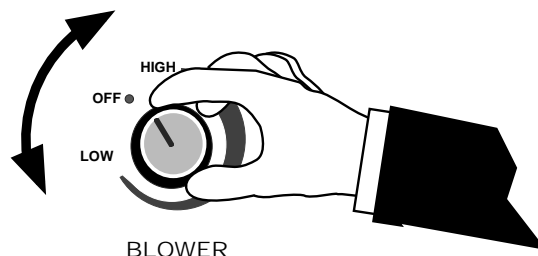

Continuous Pilot / GreenSmart™ Pilot Switch

This fireplace may run with the pilot continuously running or in GreenSmart (intermittent) mode. For most homeowners, the GreenSmart mode is preferred (this saves fuel, doesn't give off un-needed heat). However, in some situations the homeowner may prefer to switch the fireplace to continuous pilot. The most typical reasons for switching to continuous pilot are:

- Very Cold Conditions – in very cold conditions you may notice that the burner does not light quickly, and the flames lift off the burner. If this is situation, we recommend you switch to continuous pilot. This will create a slight draft in the vent, allowing for the burner to light quickly and draft correctly.
- Excessive Condensation on Glass After Startup – certain installations may encounter excessive fogging on the window after startup (not just the first time the fireplace was started). This is an aesthetic condition that may be remedied by switching the fireplace to continuous pilot.
- Cold Glass or Fireplace Front – in very cold conditions you may notice that the fireplace front and glass become very cold. To remedy this, switch the fireplace to continuous pilot.
- Frequent On / Off Operation – if you are frequently turning the fireplace on and off, you may wish to leave it in continuous pilot. This allows the burner to turn on more quickly, without pilot ignition delay.

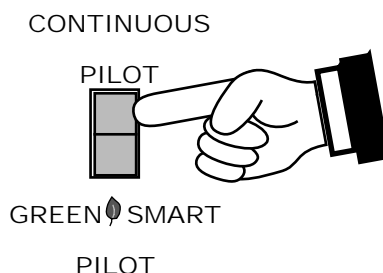

Normal Operating Sounds

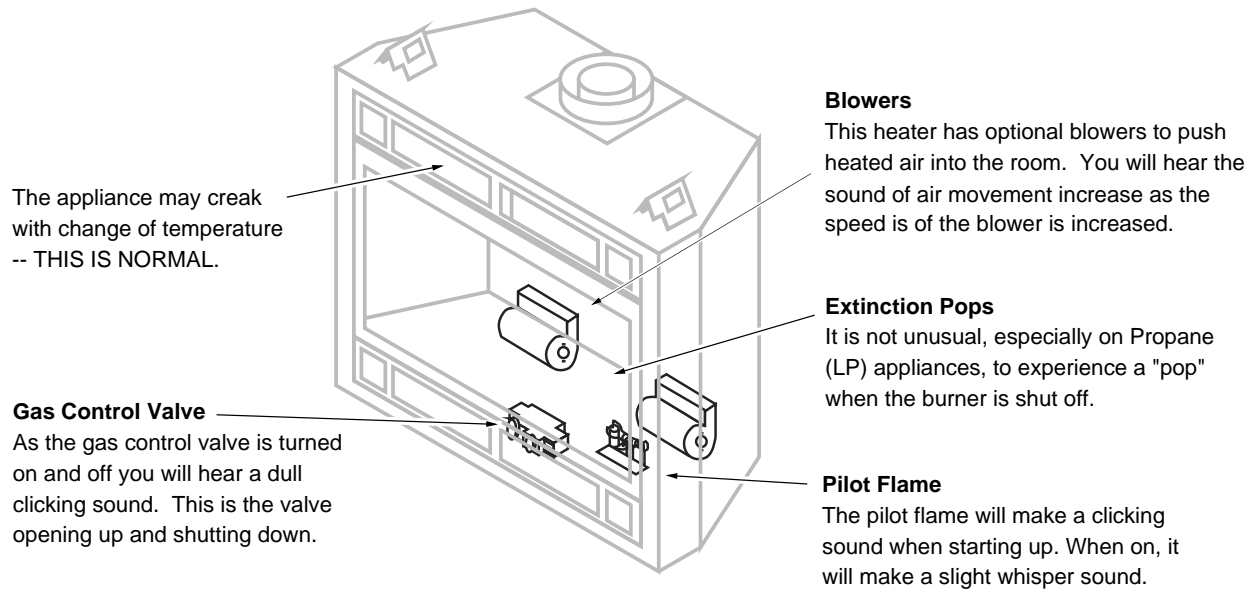

Normal Operating Odors

This appliance has several areas that reach high temperatures. Dust or other particles on these areas may burn and create an odor. This is normal during start-up. You may notice the smell is more acute if the appliance was left idle for a long period.

Maintaining Your Fireplace's Appearance

Fingerprints or other marks left on the optional plated surface may become etched in place if they are not wiped clean prior to turning the fireplace on. Clean the plated surface with denatured alcohol and a soft cloth (with the fireplace cool). Other cleaners may leave a film that may become etched into the surface.

Battery Replacement

Power Backup Batteries

Four AA batteries are used as a power backup for the fireplace in case the household (AC) power goes out. They also power the comfort control feature. These batteries must be inserted into battery holder (make sure they contact the terminals - see the illustration below). The fireplace controller will beep once these batteries start to go dead. Replace batteries before each heating season to insure proper operation.

Control Panel Light Battery

LED lights and a 9v battery are used to illuminate the control panel when the concealment cover is lifted. If the LED lights do not operate, replace the 9v battery (see the illustration below). The battery holder is held in place with Velcro and may be removed for easier access.

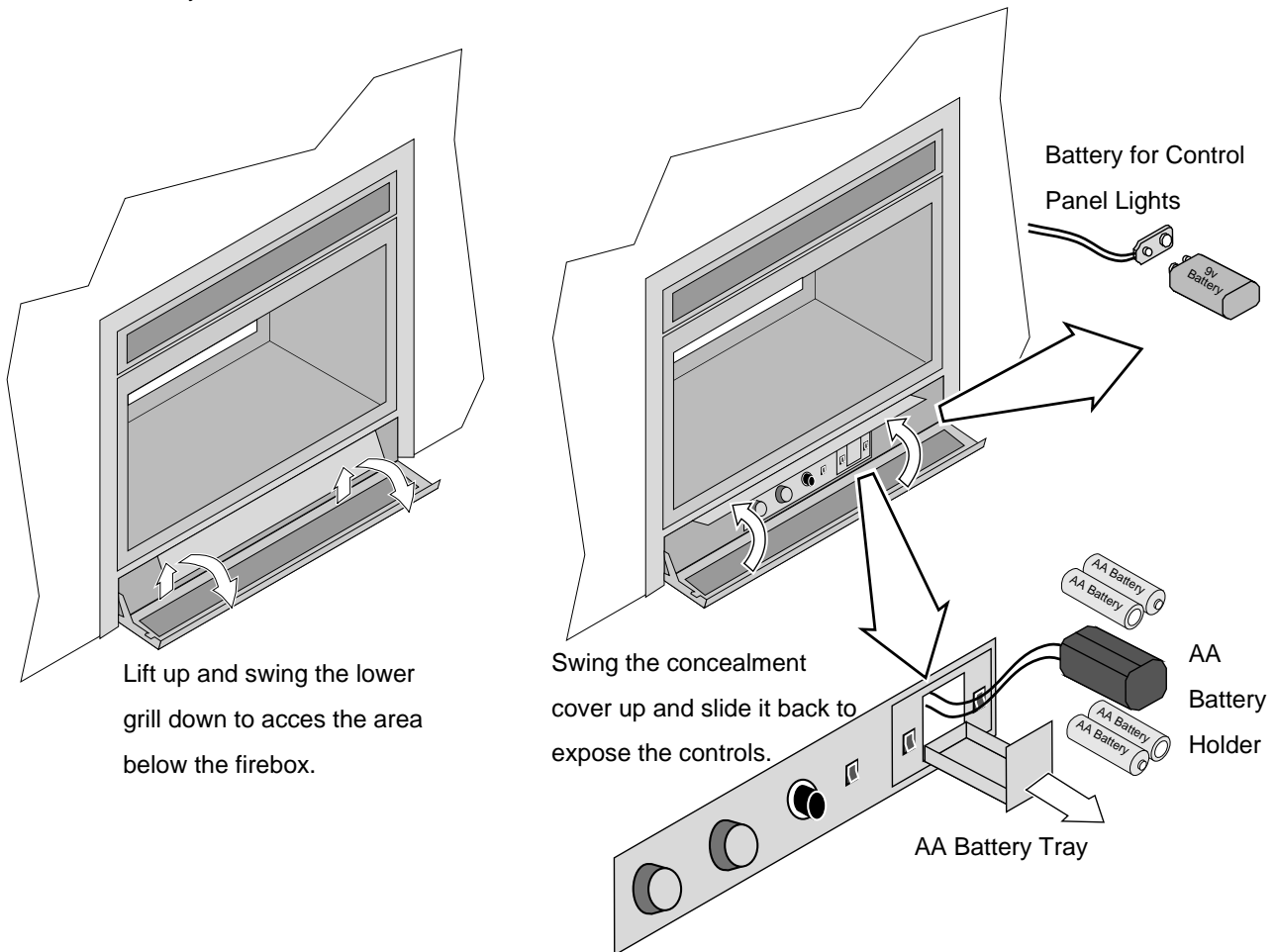

Accent Light Replacement

Two accent lights are included in your fireplace to provide additional lighting. These bulbs will burn out over time. To replace, follow the directions below:

- Shut off gas to the fireplace and let it cool for 15 minutes.
 - Remove the glass (see page 15) and logs (see page 17).
 - The bulbs may be replaced by reaching into the cavity near the firebox floor. The assembly may be removed for bulb replacement (see "a" and "b" below).
- NOTE:** Take care to not touch the bulb with your fingers (use a cloth or paper towel).

- Replace the halogen bulbs with the following bulbs:

35 Watt 120 Volt T4 Halogen Bulb (G6.35 Base)

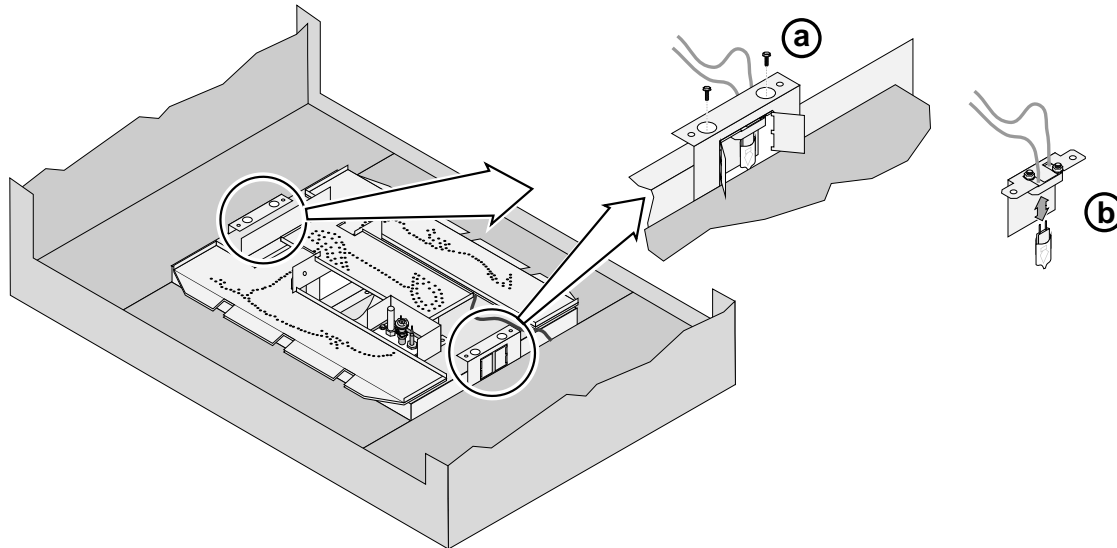

Yearly Service Procedure

- Failure to inspect and maintain the fireplace may lead to improper combustion and a potentially dangerous situation. We recommend the following procedures be done by a qualified technician.
1. Turn the pilot flame to continuous. It should touch approximately 3/8" of the top of the flame sensor. If it does not, contact your dealer for service.
 2. Shut off gas to the fireplace and let it cool for 15 minutes. Remove the glass (see page 15).
 3. Remove the log set (**NOTE: The logs are very fragile** - see page 17). If severely deteriorated, replace. Check the logs for sooting. A small amount of soot along the bottom of the logs is normal. If excessive sooting is found, the fireplace will require adjustment. Contact your dealer.
 4. Inspect the burner and remove any debris.
 - Make sure the burner is not warped, cracked, or damaged.
 - Check the firebox and area around the pilot to make sure there is no warping or damage.
 - If any problem is found, discontinue use and contact your dealer for service.
 5. Replace the log set. Clean and replace the glass (see Glass Cleaning on page 27). If the glass is damaged, replace. Make sure the gasket along the perimeter of the glass contacts the face of the firebox and forms an air-tight seal. If it does not, re-align or replace the gasket to insure an air-tight seal.
 6. Inspect the area behind the access door. Clean if necessary. Check the gas control valve and the gas lines. If damage is found, discontinue use and contact your dealer for service. Clean the air channels, ducts, and blower (if applicable).
 7. Start the main burner. After 15 minutes the flames should be orange/yellow and not touch the top of the firebox. If the pilot or main burners do not burn correctly, contact your dealer for service. Monitor blower operation.
 8. Remove any debris or vegetation near the vent termination. Contact your dealer if any sooting or deterioration is found near the vent termination.

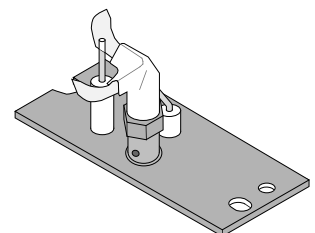

Grill Installation and Removal

Follow the directions below to install.

Upper Grill

Installation

Hold the grill at an angle and insert the lower slot over the bushing on the fireplace (both sides). You may need press on the grill to get the tab over the bushing (this prevents the grill from accidentally falling off).

Swing the grill upwards to engage the upper slot. You will need to lift the grill slightly to get it over the bushing. Once in place the grill is held in place by gravity.

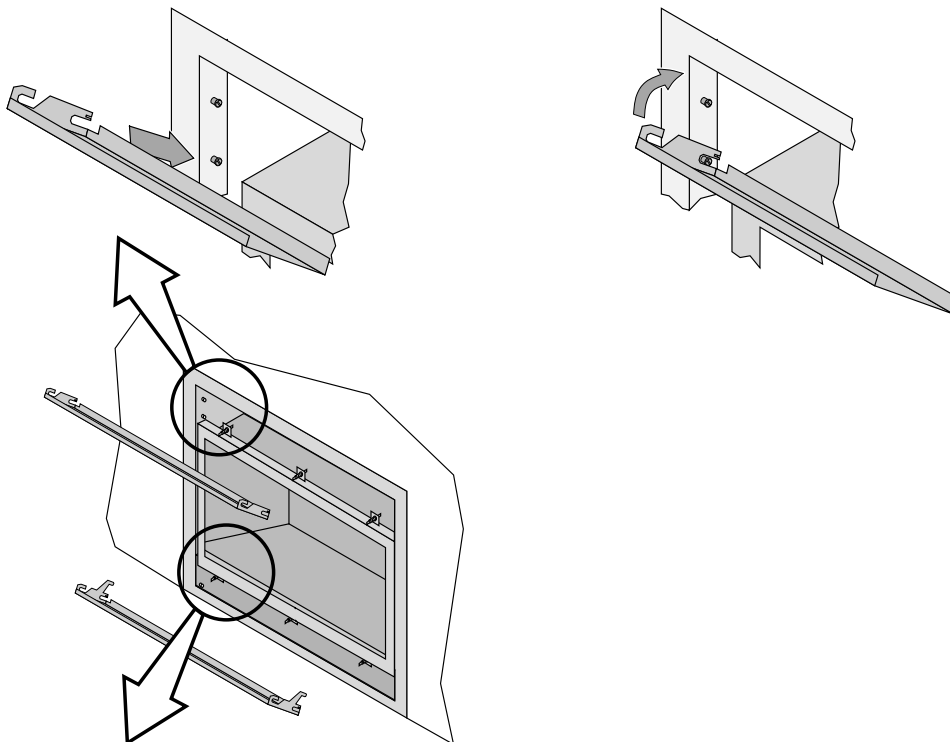

Lower Grill Installation

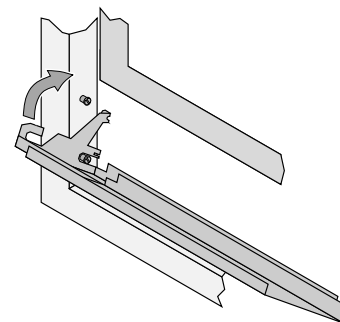
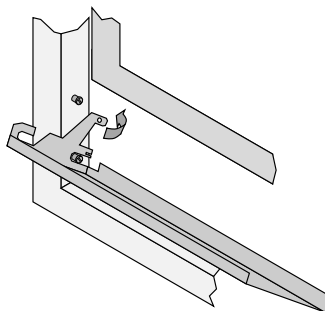
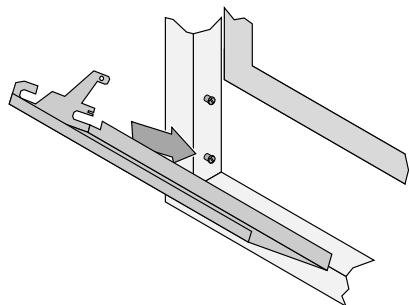

Hold the grill at an angle and insert the lower slot over the bushing on the fireplace (both sides). You may need to press on the grill to get the tab over the bushing (this prevents the grill from accidentally falling off).

Bend this the tab over on both sides. This is the end-stop for the lower grill, it allows the grill to swing forward.

Swing the grill upwards to engage the upper slot. You will need to lift the grill slightly to get it over the bushing. Once in place the grill is held in place by gravity.

Face Installation and Removal

Some fireplaces have a face that fits over the glass frame. The face can be removed following the directions below.

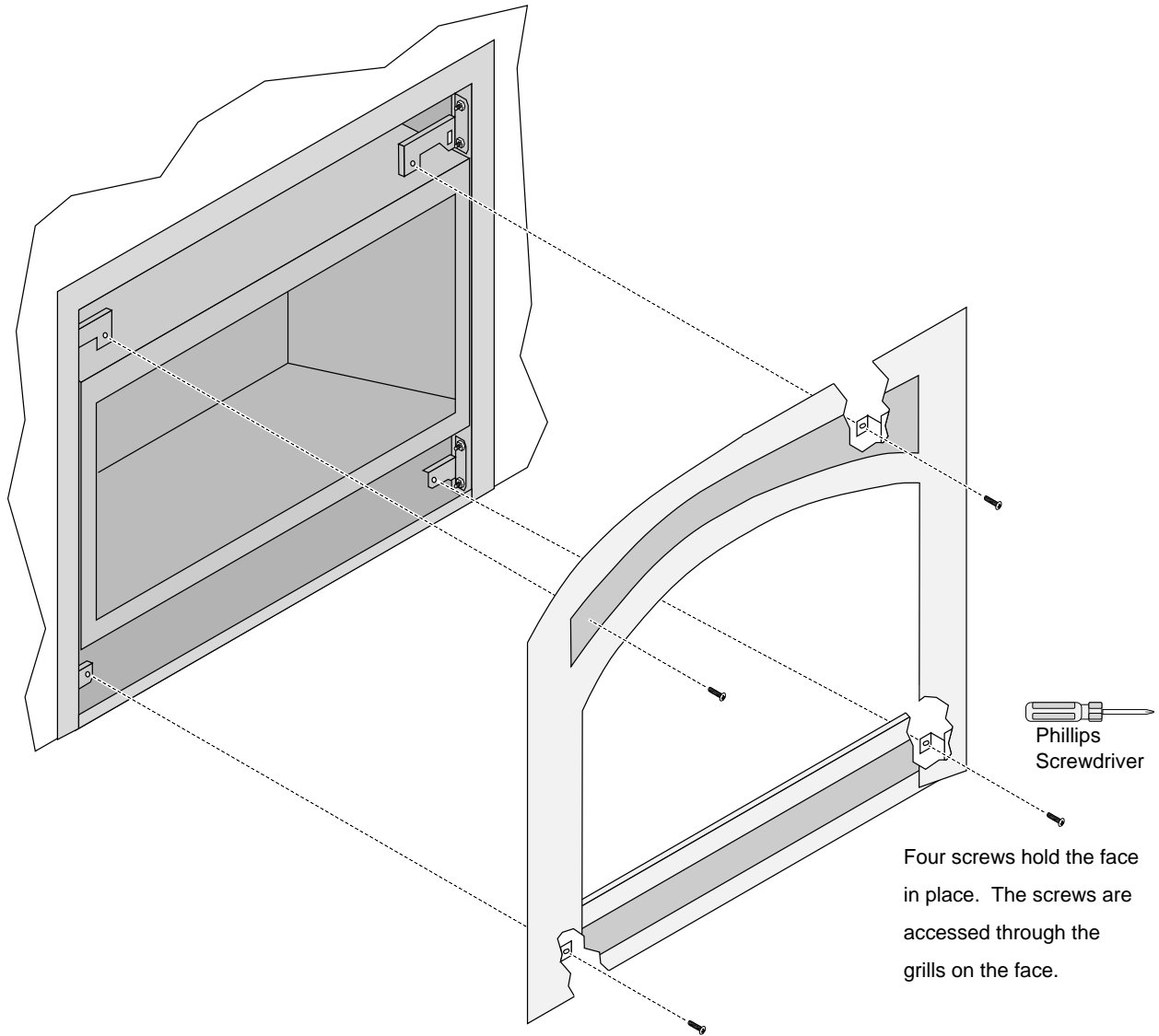

Glass Frame Removal and Installation

Warning: The appliance must be completely cool before removing the glass.

Warning: Do not strike or slam the glass.

- a** Based upon the face being used, either:
- (a) swing the access door down and remove the top grill,
 - (b) remove the face (unscrew or lift off - see the instructions included with the face for details).

Open the six latches holding the glass frame in place (start with the bottom three) - follow the directions shown to the right.

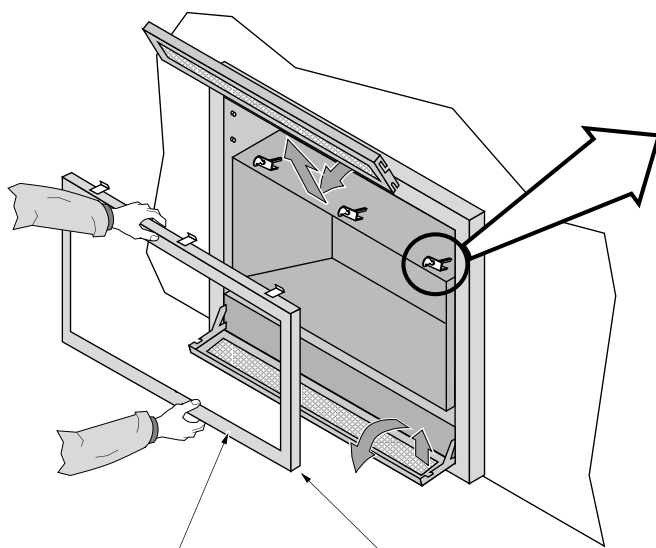

- b** Lift the glass frame up and pull it forward to remove.

NOTE:
You may need to lift the glass frame while re-attaching.

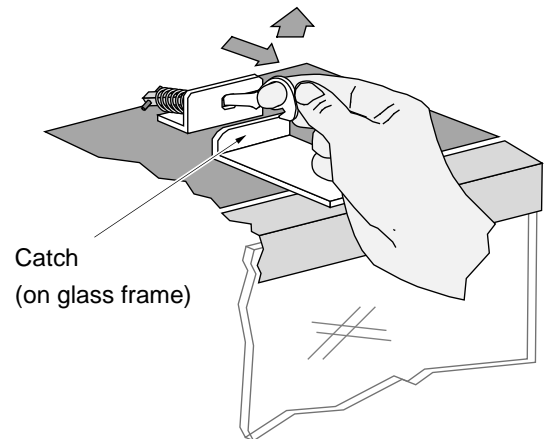
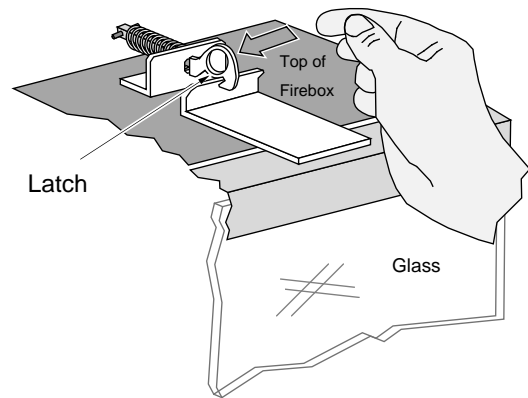

Re-Attaching the Glass Frame:

- a) Hang the glass frame on the firebox.
- b) While holding in place, attach the upper latches (follow the instructions above in reverse).
- c) Lift the glass frame slightly and attach the lower latches.

NOTE: Make sure the glass frame is all the way in place - it should be flush with the front of the fireplace when installed.

Glass Frame Removal and Installation (continued)

The latch can come loose from the latch assembly. This occurs only when it is rotated. Follow the directions below to re-install the latch if it comes loose.

Hold the latch at an angle and insert it into the slot on the glass frame anchor.

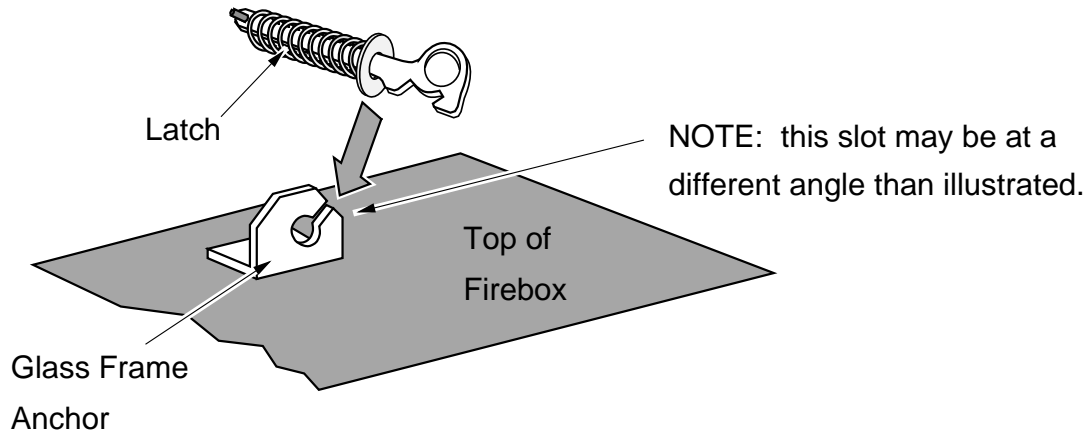

Note how the washer on the latch fits behind the flange on the glass frame anchor.

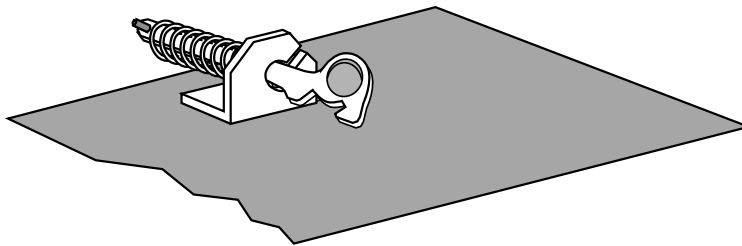

Once fully inserted, turn the latch until it is upright.

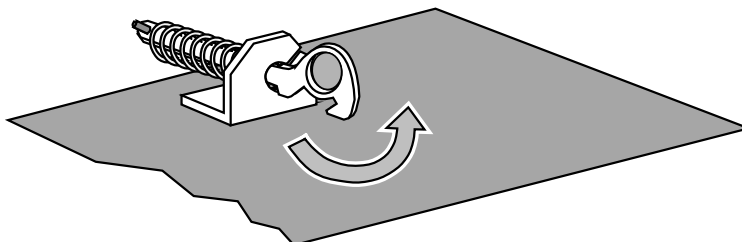

Log Set Installation

Logs in Place – FRONT SIDE (gas control valve side)

NOTE: This fireplace has a front side and back side. The front side (pictured below) is the side with the gas control valve.



Logs in Place – BACK SIDE



Center Log Installation

The log shelf has two tabs used to align the center log. Bend these tabs as shown to the right.

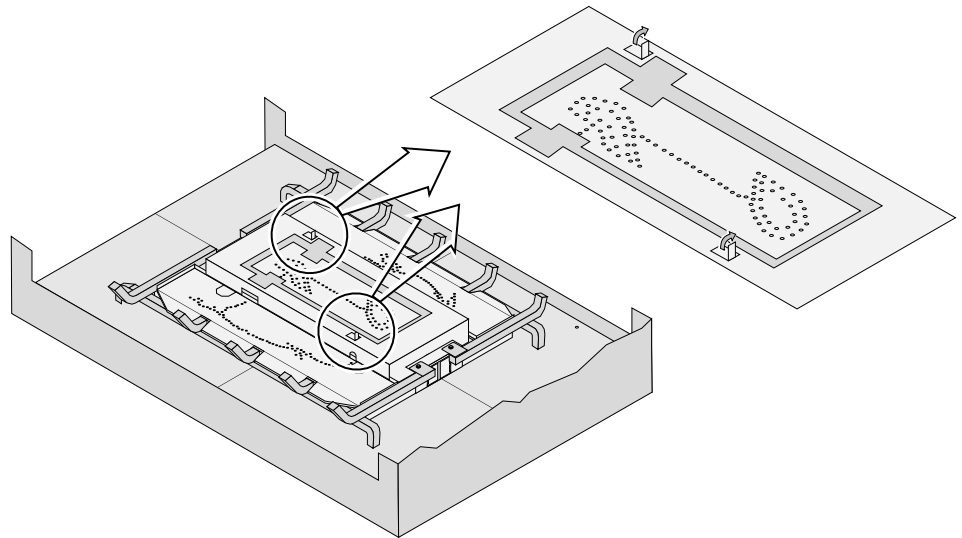

Bend these two tabs up 90°. They are used as pins to locate the center log.

Place the center log in place. Make sure the two tabs on the log shelf insert into the two holes on the bottom of the log.

Once in place, rotate the log clockwise until the indents in the log contact the grate.

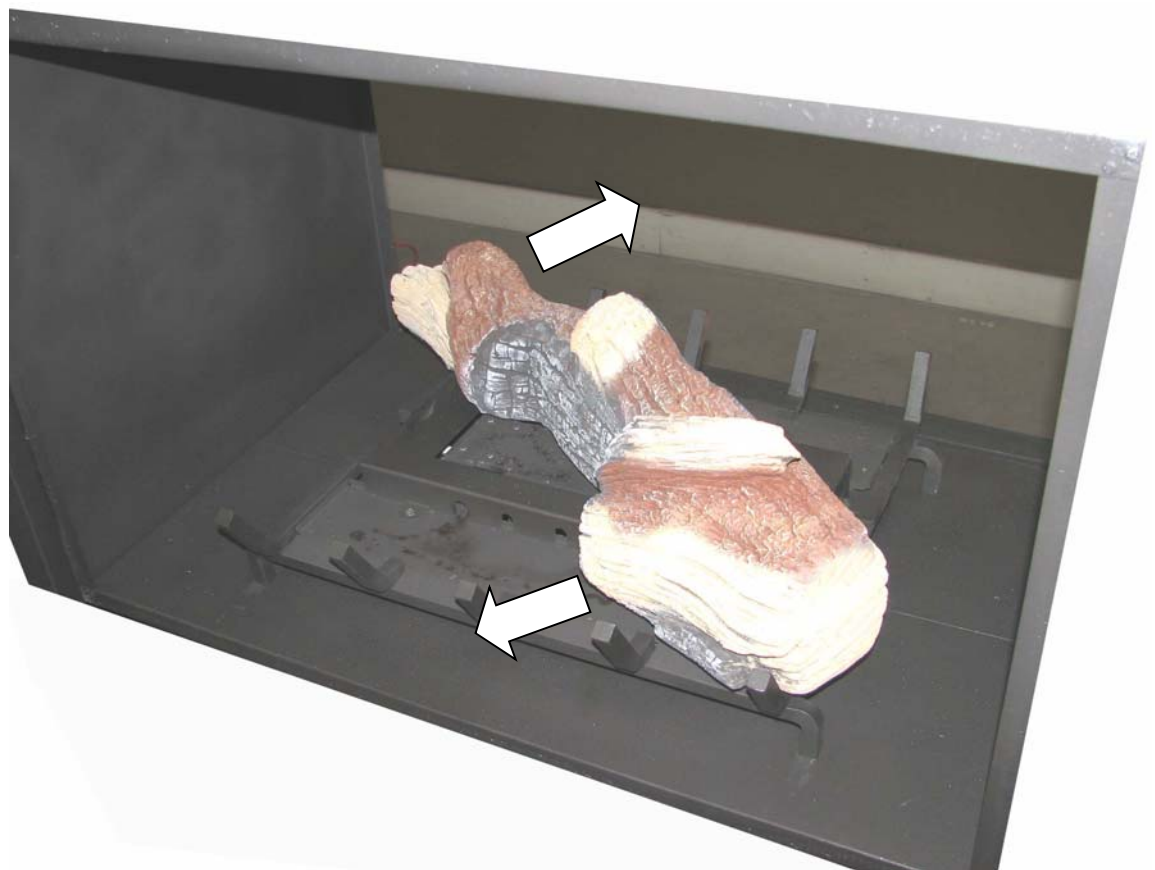

Front Left Log

Place the front left log as shown below. There is a ledge on the bottom of the log that aligns with the edge of the center burner.



When in place, the front left log has a small gap to the center log.

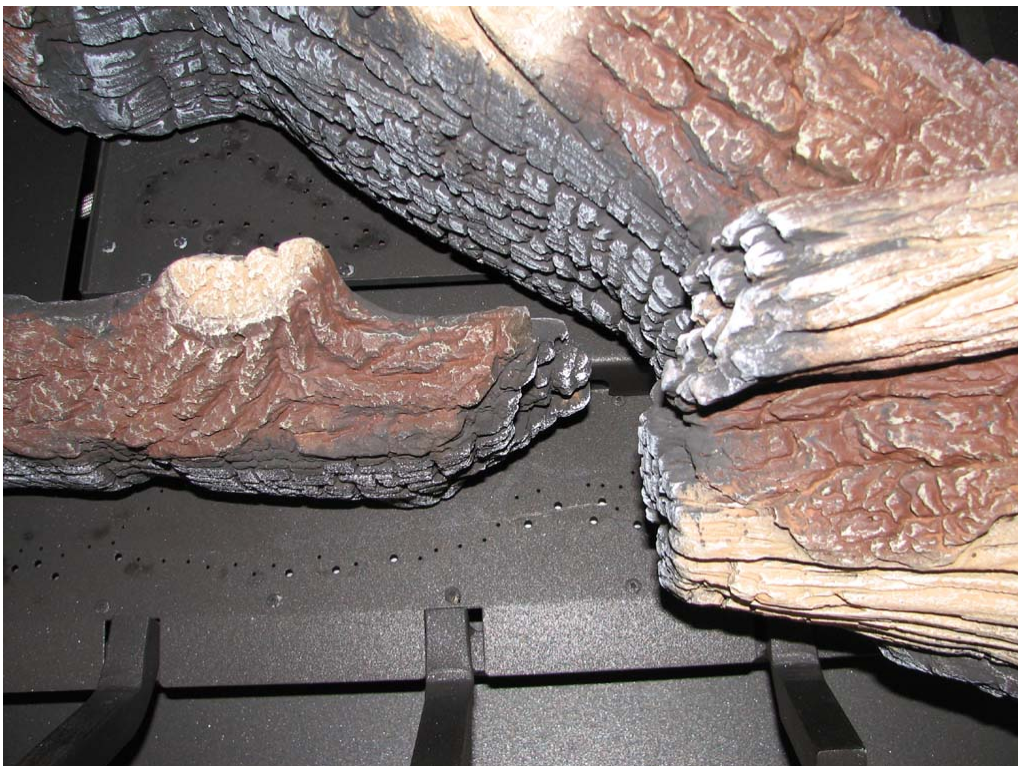

Front Left Upper Log

There are two pins on the front left log. The pin to the right is used to locate the front left upper log.



The front left upper log has a groove and one hole on the bottom. The groove fits over the edge of the burner.



When in place, the front left upper log looks like the picture to the right.



Front Upper Center Log

The front upper center log has two holes on its bottom surface. One of the holes fits over the pin on the center log (see picture to the right). The other fits over the pin on the front left log.



When in place, the front upper center log looks like the picture to the right.



Back Left Log

The back left log fits to the left of the center log.



The groove on the bottom of the log fits over the upper burner tray.



Make sure to slide the log towards the center of the firebox. When in place, the log will appear as shown in the picture to the right.

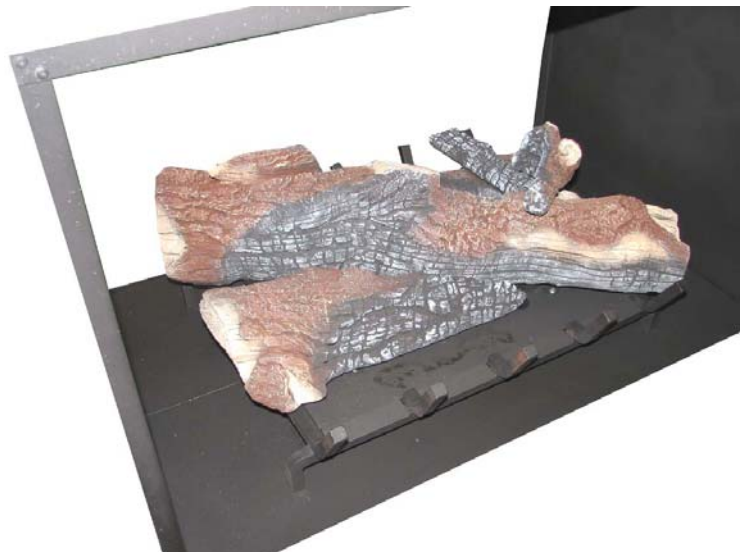

Right Ember Chunk

The right ember chunk is installed from the back. The groove on the bottom of the ember fits over the edge of the upper burner tray. It wedges between the two logs..



When in place, the left ember chunk looks like the picture to the right.



Back Ember Chunk

The back ember is placed on the back right side as shown in the picture to the right. Make sure it is not over any burner holes.

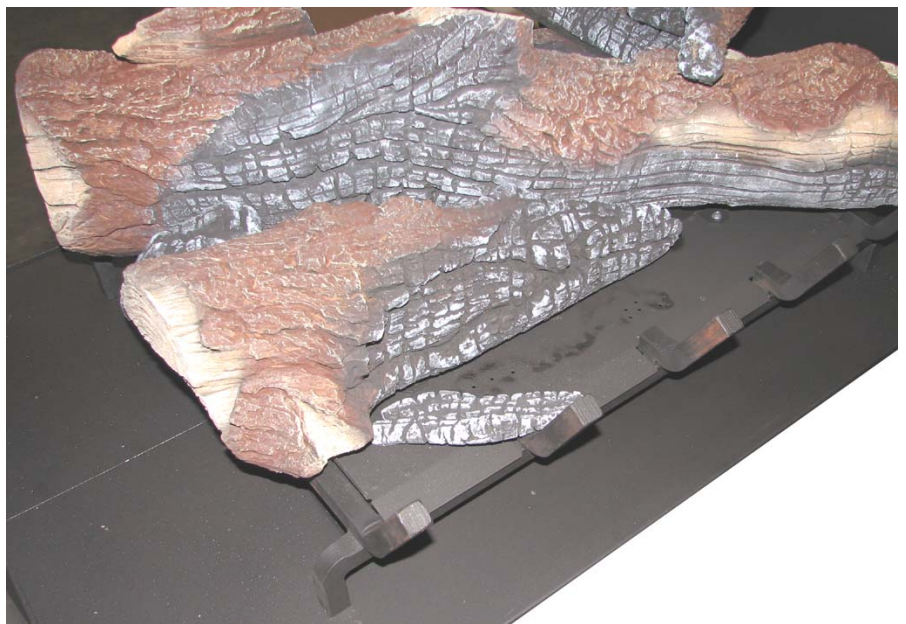

Back Left Log

The pin on the center log inserts into the hole on the back of the back left log.



This groove on the log fits over the grate.



When in place, the log looks like the picture to the right.



Back Upper Right Log

Pins on the center log and back right log help locate this log.



When in place, the back upper right log looks like the picture to the right.



Ember Placement

A bag of embers is provided to further enhance the firebox. Place the embers on the firebox floor and on the outer burner (especially over exposed rivets on the burner). Do not place embers over any of the burner holes or air channels. See the picture below.



NOTE: When placing the embers, place one ember on both sides of the accent light deflectors (see illustration below). This helps block light from exiting the slot on the deflector and creating a line of light.

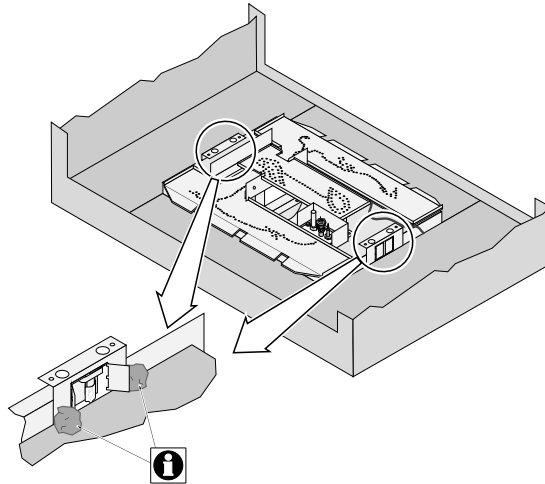

Rock Wool Placement

The included rock wool is placed on top of the burner to enhance the glow from the burner. **The rock wool works best when it is applied in a very thin, porous layer.** The best method for applying the rock wool is to brush it on to the burner. Compress a clump of rockwool between your thumb and forefinger. Use a stiff brush to apply a thin layer of rockwool fibers onto the burner. Do not use the entire bag of rockwool. Use only a small amount and save the remainder. Over-use of rockwool will diminish the glow and may cause sooting or other adverse conditions.

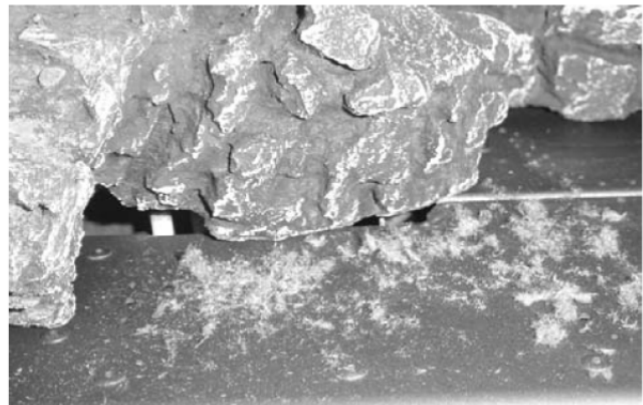

Glass Cleaning

The glass may be cleaned with a non-abrasive cleaner. To clean the inside of the glass, simply remove the glass frame, place it on a non-scratching surface, and clean the inside surface.

If the outside surface of the glass frame requires cleaning, follow the directions below to remove the outer glass frame and screen.

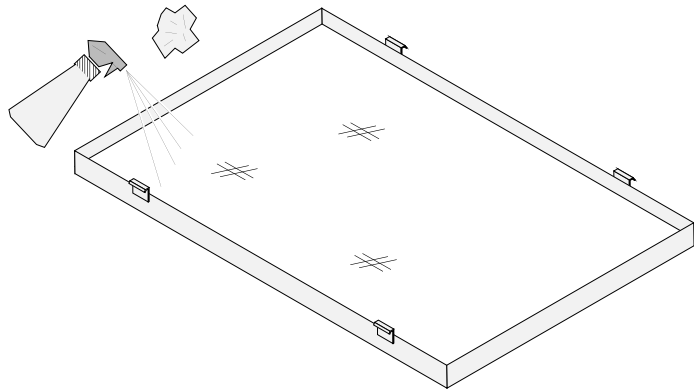

WARNING: do not operate the fireplace without the glass frame in place.

Six sets of tabs hold the glass (and glass gasket) in place. Four of these tabs are at the corners, two are at the top and bottom of the glass frame.

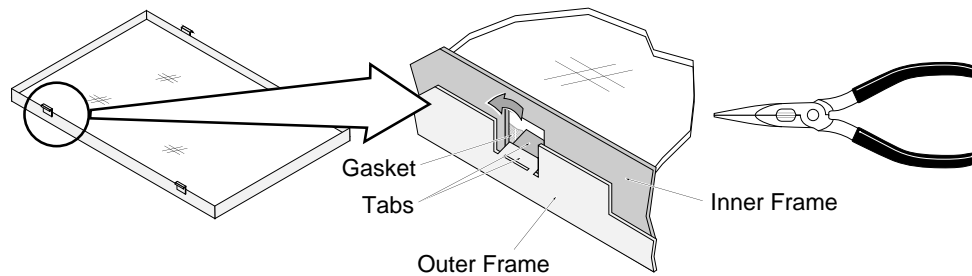

REMOVAL INSTRUCTIONS: carefully bend the tabs out with needle-nose pliers (there are tabs on the inner and outer frame - the center tabs only have tabs on the inner frame). Do not pry these tabs, this may cause the glass to crack.

REPLACEMENT INSTRUCTIONS: carefully bend the tabs inward, making sure the tabs contact the gasket, not the glass. Bend the tab inwards 30°- do not over-bend the tabs.

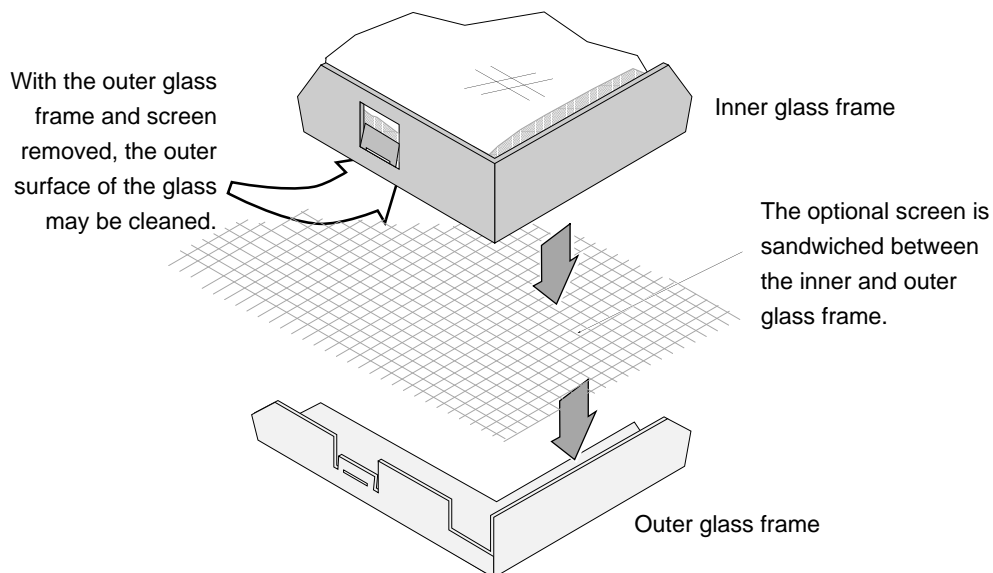

Troubleshooting Table

Problem:	Possible Cause:	Don't Call for Service Until You:
Main Burners Will Not Start	The ON/OFF switch is turned to "OFF"..... The remote control is not working correctly..... The thermostat is disconnected or set too low..... No Propane in Tank.....	Turn the ON/OFF switch to "ON" See the remote control instructions See "Thermostat Operation" Check Tank Level
Heater Beeps	The power backup batteries are dead (heater will beep once repeatedly)..... The heater encountered an error when trying to start (heater beeps 3 times repeatedly)..... The heater encountered a pilot error (heater beeps 2 times repeatedly).....	Replace the batteries (see page 11) Make sure gas is turned on. Turn heater off for 5 seconds (make sure standing pilot is off) – then turn back on. Contact your dealer if this occurs.
Thermostat Does Not Work	The ON/OFF switch is turned to "OFF"..... The thermostat is set too low.....	Turn the ON/OFF switch to "ON" Check thermostat
Fireplace Will Not Distribute Heat	The fireplace is not getting electricity..... The fireplace is not up to temperature..... <u>The blower fuse may be blown</u>	Check the breaker switch Let the fireplace burn for at least 15 minutes Replace the blower fuse. See fuse location below.
Flames Are Too Blue	The fireplace has just been started..... Improper air shutter adjustment.....	This is normal - see "Starting the Fireplace for the First Time" Adjust Air Shutter - contact your dealer
Flames Are Too Short (Under 6")	The flame height may be turned too low.....	Turn the flame height to "HI" - See "Adjusting the Flame Height"
Comfort Control Does not Work	The AA batteries may be dead.....	Replace the AA batteries (see page 11)
Thin Layer of Soot Covers the Glass	The logs or coals are placed incorrectly..... Improper air shutter adjustment.....	See "Log Set Installation" Adjust Air Shutter - contact your dealer
Accent Light Does Not Work	The bulb may be burned out..... The accent light fuse may be blown.....	See "Accent Light Replacement" on page 12 Replace the fuse. See fuse location below.

Location of fuses (2.5 amp):



Wiring Diagram

Caution: Label all wires prior to disconnection when servicing controls. Wiring errors can cause improper and dangerous operation.

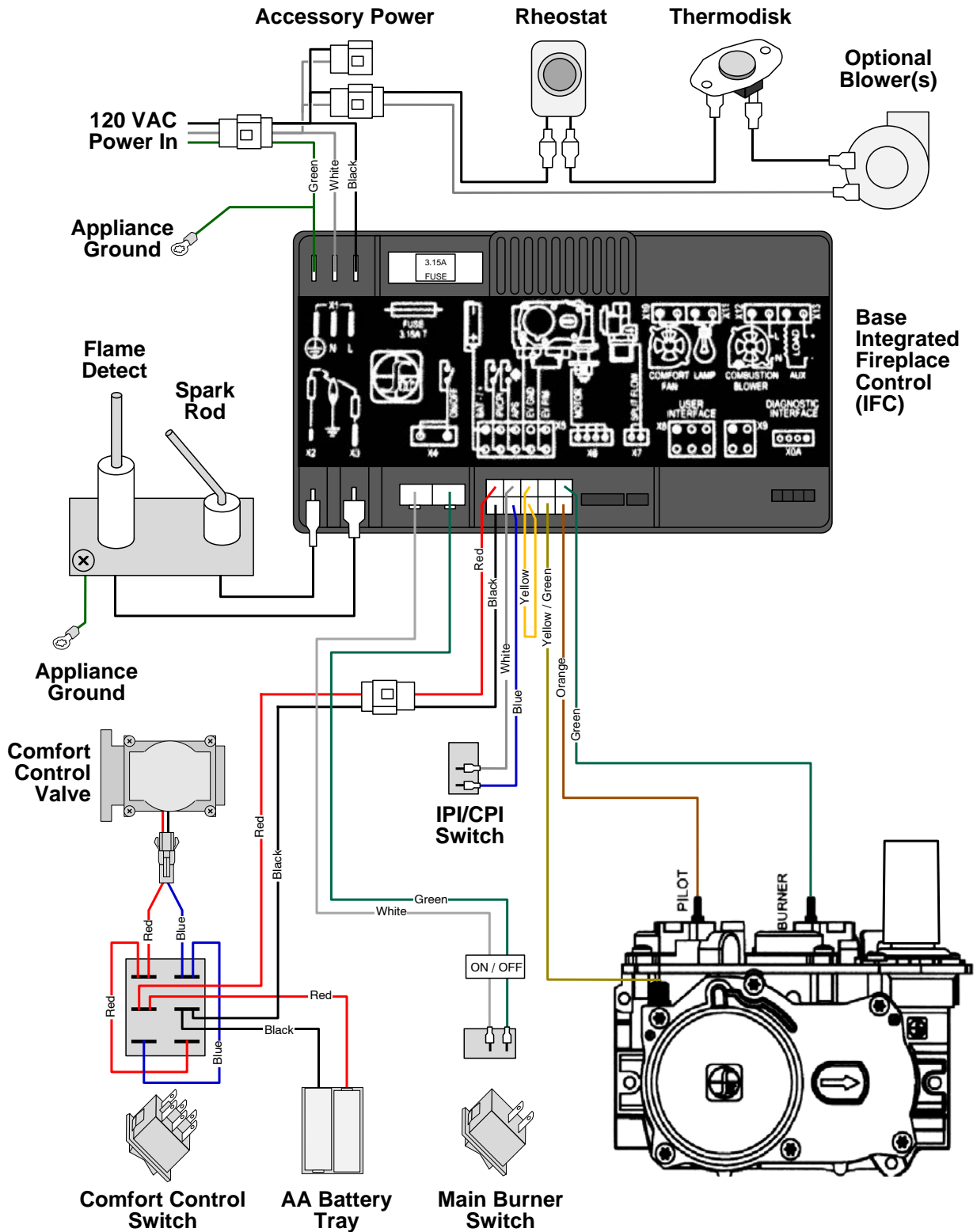

GS2 Remote Wiring Diagram

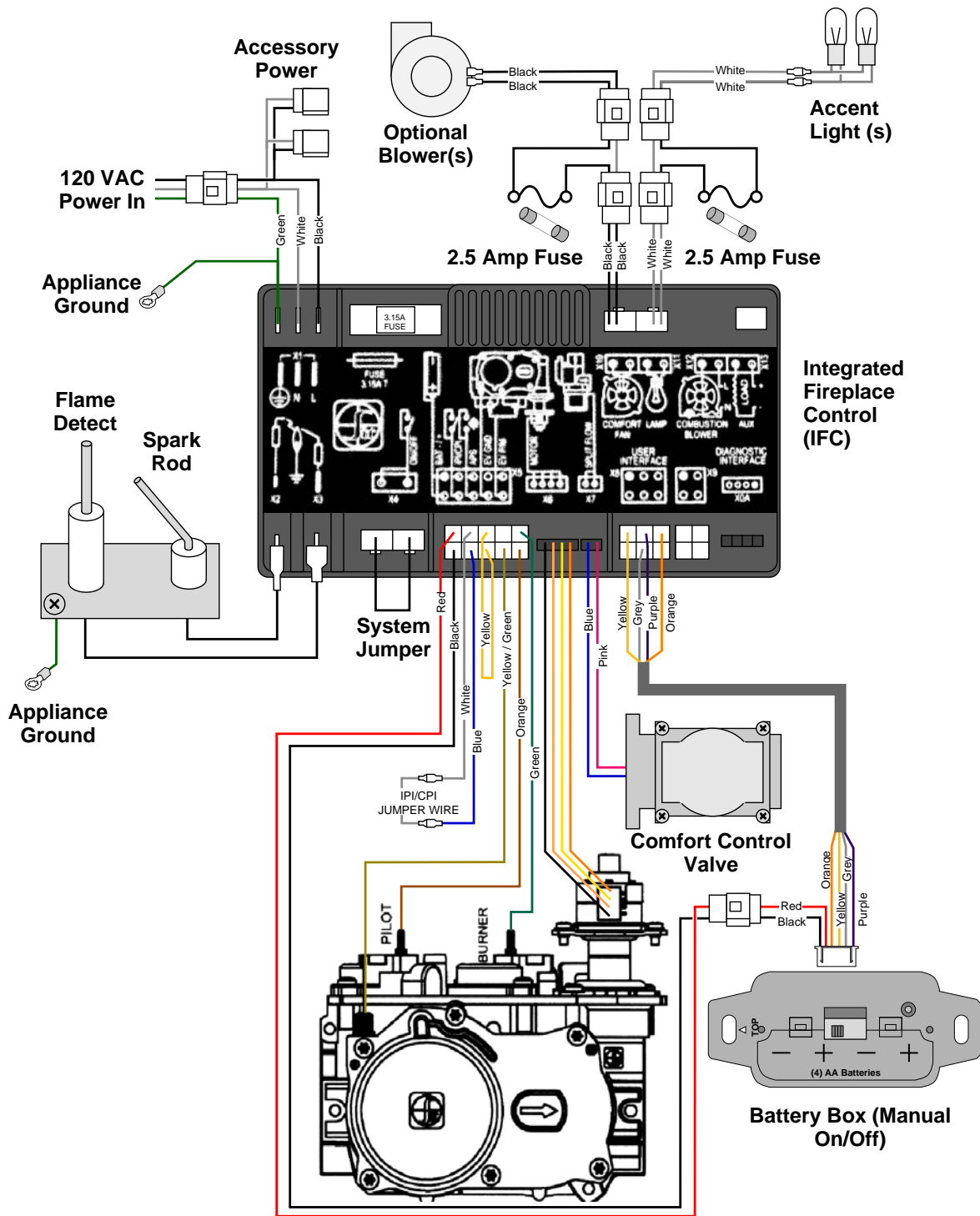

Replacement Parts List

Caution: Use only Travis Industries replacement parts. Do not use substitute materials.

Warning: Do not operate appliance with the glass front removed, cracked, or broken. Replacement of the glass should be done by a licensed or qualified service person.

Contact your local Travis Industries Dealer for a Replacement Parts List

Limited 7 Year Warranty

31

Register your TRAVIS INDUSTRIES, INC. Limited 7 Year Warranty online at traviswarranty.com, or complete the enclosed Warranty card and mail it within **ten (10)** days of the appliance purchase date to: TRAVIS INDUSTRIES, INC., 4800 Harbour Pointe Blvd. SW, Mukilteo, WA 98275. TRAVIS INDUSTRIES, INC. warrants this gas appliance (appliance is defined as the equipment manufactured by Travis Industries, Inc.) to be defect-free in material and workmanship to the original purchaser from the date of purchase as follows:

**Check with your dealer in advance for any costs to you when arranging a warranty call.
Mileage or service charges are not covered by this warranty. This charge can vary from store to store.**

Component	Years 1 & 2 Parts & Labor	Years 3 Through 5 Parts & Labor	Years 6 & 7 Parts Only
Burner Assembly Burner Pan Assembly, Air Shutter Assembly, Main Burner Orifice	✓		
Electrical Assembly (within heater structure): Wiring harness, snap discs, rheostat speed control, blower.	✓		
Gas Control Assembly Adjustable control valve, fireplace controller, pilot assembly and pilot wiring	✓		
Glass Glass (breakage from thermal shock)	✓		
Ceramic Logs Log Set, Embers	✓		
Gold, Nickel & Copper Plating Face & Door (see "Conditions and Exclusions" # 9)	✓		
Accessories Firebacks, Power Heat Ducts, Andirons, etc...	✓		
One-Way Freight Allowance One-way freight allowance on pre-authorized repair done at factory is covered.	✓	✓	
Convection Heat Exchanger Convection heat exchanger assembly	✓	✓	
Firebox Assembly Adjustable Air Restrictor, Pressure Relief Mechanisms, Glass Attachment Mechanism	✓	✓	✓

EXCLUDED COMPONENTS:

Paint, Gasketing, and Accent Light Bulbs

CONDITIONS & EXCLUSIONS

- This new gas appliance must be installed by a qualified gas appliance technician. It must be installed, operated, and maintained at all times in accordance with the instructions in the Owner's Manual. Any alteration, willful abuse, accident, neglect, or misuse of the product shall nullify this warranty.
- This warranty is nontransferable, and is made to the ORIGINAL purchaser, provided that the purchase was made through an authorized TRAVIS dealer.
- Discoloration and some minor expansion, contraction, or movement of certain parts and resulting noise, is normal and not a defect and, therefore, not covered under warranty. The installer must ensure the appliance is burning as per the rating tag at the time of installation. Over-firing (operation above the listed BTU rate) of this appliance can cause serious damage and will nullify this warranty.
- The warranty, as outlined within this document, does not apply to the chimney components or other Non-Travis accessories used in conjunction with the installation of this product. If in doubt as to the extent of this warranty, contact your authorized TRAVIS retailer before installation.
- Travis Industries will not be responsible for inadequate performance caused by environmental conditions such as nearby trees, buildings, roof tops, wind, hills or mountains or negative pressure or other influences from mechanical systems such as furnaces, fans, clothes dryers, etc.
- This Warranty is void if:
 - The unit has been operated in atmospheres contaminated by chlorine, fluorine or other damaging chemicals.
 - The unit is subject to submersion in water or prolonged periods of dampness or condensation.
 - Any damage to the unit, combustion chamber, heat exchanger or other components due to water, or weather damage which is the result of, but not limited to, improper chimney/venting installation.
- Exclusions to this 7 Year Warranty include: injury, loss of use, damage, failure to function due to accident, negligence, misuse, improper installation, alteration or adjustment of the manufacturer's settings of components, lack of proper and regular maintenance, damage incurred while the appliance is in transit, alteration, or act of God.
- This 7 Year warranty excludes damage caused by normal wear and tear, such as paint discoloration or chipping, worn or torn gasketing, corroded or cracked logs, embers, etc. Also excluded is damage to the unit caused by abuse, improper installation, modification of the unit, drilling of the orifices, or the use of fuel other than that for which the unit is configured. Units are shipped for natural gas and must be converted to propane using the included conversion kit. Confirm fuel configuration with your installer.
- Damage to gold or nickel surfaces caused by fingerprints, scratches, melted items-, or other external sources left on the gold or nickel from the use of cleaners other than denatured alcohol is not covered in this warranty.
- TRAVIS INDUSTRIES, INC. is free of liability for any damages caused by the appliance, as well as inconvenience expenses and materials. Incidental or consequential damages are not covered by this warranty. In some states, the exclusion of incidental or consequential damage may not apply.
- This warranty does not cover any loss or damage incurred by the use or removal of any component or apparatus to or from the gas appliance without the express written permission of TRAVIS INDUSTRIES, INC. and bearing a TRAVIS INDUSTRIES, INC. label of approval.
- Any statement or representation of TRAVIS products and their performance contained in TRAVIS advertising, packaging literature, or printed material is not part of this 7 year warranty.
- This warranty is automatically voided if the appliance's serial number has been removed or altered in any way. If the appliance is used for commercial purposes, it is excluded from this warranty.
- No dealer, distributor, or similar person has the authority to represent or warrant TRAVIS products beyond the terms contained within this warranty. TRAVIS INDUSTRIES, INC. assumes no liability for such warranties or representations.
- Travis Industries will not cover the cost of the removal or re-installation of hearths, facing, mantels, venting or other components.
- If for any reason any section of this warranty is declared invalid, the balance of the warranty remains in effect and all other clauses shall remain in effect.
- THIS 7 YEAR WARRANTY IS THE ONLY WARRANTY SUPPLIED BY TRAVIS INDUSTRIES, INC., THE MANUFACTURER OF THE APPLIANCE. ALL OTHER WARRANTIES, WHETHER EXPRESS OR IMPLIED, ARE HEREBY EXPRESSLY DISCLAIMED AND PURCHASER'S RECOURSE IS EXPRESSLY LIMITED TO THE WARRANTIES SET FORTH HEREIN.**

IF WARRANTY SERVICE IS NEEDED:

- If you discover a problem that you believe is covered by this warranty, you MUST REPORT it to your TRAVIS dealer WITHIN 30 DAYS, giving them proof of purchase, the purchase date, and the model name and serial number.
- Travis Industries has the option of either repairing or replacing the defective component.
- If your dealer is unable to repair your appliance's defect, he may process a warranty claim through TRAVIS INDUSTRIES, INC., including the name of the dealership where you purchased the appliance, a copy of your receipt showing the date of the appliance's purchase, and the serial number on your appliance. At that time, you may be asked to ship your appliance, freight charges prepaid, to TRAVIS INDUSTRIES, INC. TRAVIS INDUSTRIES, INC., at its option, will repair or replace, free of charge, your TRAVIS appliance if it is found to be defective in material or workmanship within the time frame stated within this 7 year warranty. TRAVIS INDUSTRIES, INC. will return your appliance, freight charges (years 1 to 5) prepaid by TRAVIS INDUSTRIES, INC., to your regional distributor, or dealership.
- Check with your dealer in advance for any costs to you when arranging a warranty call. Mileage or service charges are not covered by this warranty. This charge can vary from store to store.

Accessories

The accessories listed below are available at your Travis dealer. To locate a dealer, visit:

www.travisproducts.com

GreenSmart™ Remote / Thermostat

This accessory allows for remote control of your fireplace (burner, flame height, accent light).. It has a built-in thermostat if you wish for automatic temperature control.

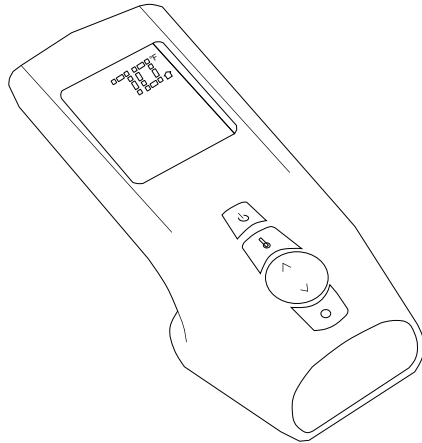

Blower

The optional blowers help transfer heat to your home.

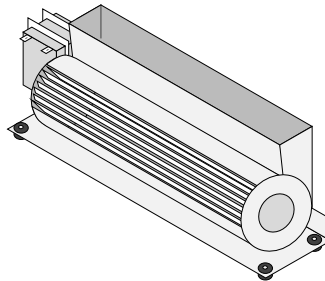

Firebacks

There are several styles of decorative firebacks that fit inside the firebox and enhance the area behind the flames.

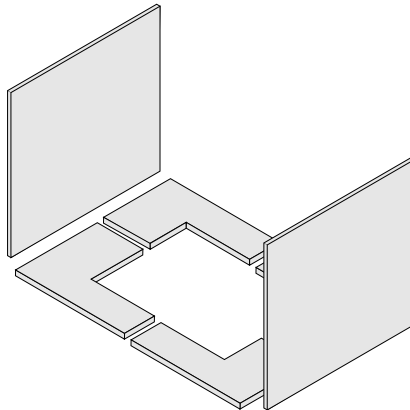

Index

Accent Light	8	Installation Warnings	2
Accent Light Replacement	12	Location of Controls	6
Accessories	32	Log Set Installation	17
Adjusting the Flame Height	8	Maintaining Your Fireplace's Appearance	11
Adjusting the Optional Blower Speed	9	Normal Operating Odors	10
Battery Replacement	11	Normal Operating Sounds	10
Comfort Control	7	Replacement Parts List	30
Continuous Pilot / GreenSmart™ Pilot Switch	9	Rock Wool Placement	26
Face Installation and Removal	14	Starting the Fireplace for the First Time	7
Glass Cleaning	27	Troubleshooting Table	28
Glass Frame Removal and Installation	15	Turning the Fireplace On and Off	7
Grill Installation and Removal	13	Wiring Diagram	29
Heating Specifications	3	Yearly Service Procedure	12