

**PELLET FUELED FREESTANDING RESIDENTIAL
AND
MOBILE HOME ROOM HEATER**

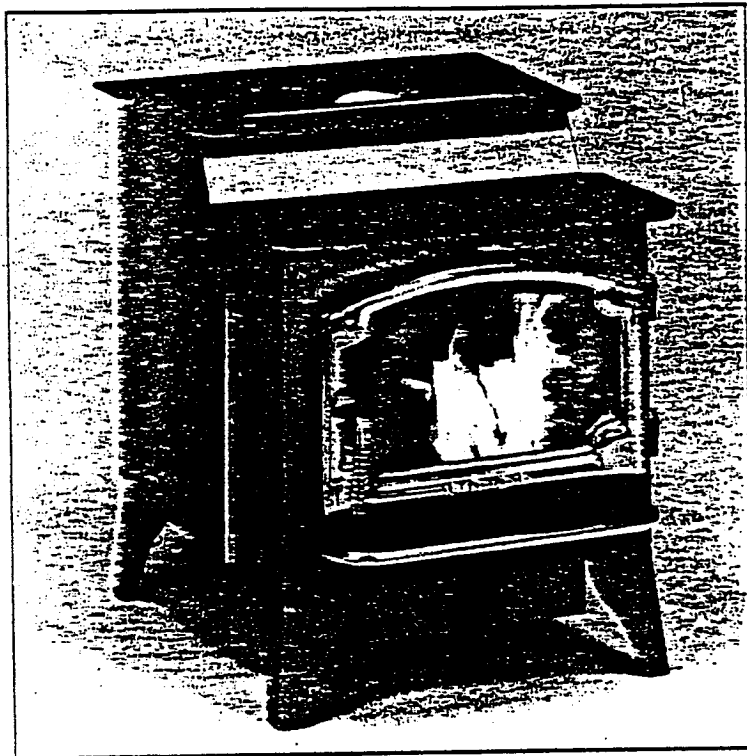

**Model: 400 - PS
OWNERS MANUAL**

**PREPARATION, INSTALLATION, OPERATION
AND MAINTENANCE**

KEEP THIS MANUAL

March 1990

**Tested to UL1482/ULCS627/CSAB366.2/AFPI
Standards By: Warnock Hersey Professional Services LTD.**

**This pellet fired appliance has been tested and listed for
use in manufactured homes in accordance with Oregon
Administrative Rules 814-23-900 through 909**

Manufactured By:



Travis Industries, Inc.

10850 117th Place N.E. Kirkland, WA 98033

© Copyright 1990 T.I.

SAFETY PRECAUTIONS

- 1 VIEWING DOOR AND ASHPAN MUST BE CLOSED AND LATCHED DURING OPERATION.
- 2 THIS STOVE MUST BE PROPERLY INSTALLED IN ORDER TO PREVENT THE POSSIBILITY OF A HOUSE FIRE. FOR YOUR SAFETY THE INSTALLATION INSTRUCTIONS MUST BE STRICTLY ADHERED TO. DO NOT USE MAKESHIFT METHODS OR COMPROMISE INSTALLATION.
- 3 CONTACT YOUR LOCAL BUILDING OFFICIALS TO OBTAIN A PERMIT AND INFORMATION ON ANY INSTALLATION RESTRICTIONS OR INSPECTION REQUIREMENTS IN YOUR AREA. ALSO, NOTIFY YOUR INSURANCE COMPANY THAT YOU ARE INSTALLING A PELLET BURNING APPLIANCE.
- 4 THIS UNITS EXHAUST SYSTEM WORKS WITH A NEGATIVE COMBUSTION CHAMBER PRESSURE AND A LOW POSITIVE CHIMNEY PRESSURE. IT IS VERY IMPORTANT THAT THE EXHAUST SYSTEM BE COMPLETELY AIRTIGHT AND PROPERLY INSTALLED. THE CHIMNEY JOINTS SHOULD BE SEALED WITH R T V 500 DEGREES FAHRENHEIT (500 F) (260 C) SILICONE SEALANT. IMPROPERLY INSTALLED STOVES ARE THE MAJOR CAUSE OF HOME FIRES.
- 5 NEVER BLOCK FREE AIRFLOW THROUGH OPEN VENTS.
- 6 NEVER TRY TO REPAIR OR REPLACE ANY PART OF THE APPLIANCE UNLESS INSTRUCTIONS ARE GIVEN IN THIS MANUAL. ALL OTHER WORK SHOULD BE DONE BY A TRAINED TECHNICIAN.
- 7 WAIT UNTIL APPLIANCE HAS COOLED BEFORE CARRYING OUT MAINTENANCE PROCEDURES.
- 8 TRAVIS INDUSTRIES, INC. GRANTS NO WARRANTY IMPLIED OR STATED, FOR THE INSTALLATION OR MAINTENANCE OF YOUR STOVE, AND ASSUMES NO RESPONSIBILITY FOR ANY CONSEQUENTIAL DAMAGE(S).
- 9 DO NOT INSTALL IN A BEDROOM.
- 10 KEEP FOREIGN OBJECTS OUT OF THE HOPPER.
- 11 ALWAYS FOLLOW THE INSTRUCTIONS IN THE OWNERS MANUAL
- 12 KEEP THIS MANUAL FOR LATER USE.
- 13 THE 400 - PS PELLET APPLIANCE IS DESIGNED AND APPROVED FOR BURNING OF PELLETIZED, WOOD FUEL ONLY. THE BURNING OF ANY OTHER TYPE FUEL OTHER THAN THAT LISTED WILL VOID ALL WARRANTIES AND SAFETY LISTING OF THE UNIT. DO NOT ATTEMPT TO BURN ANY OTHER FUEL THAN SPECIFIED IN THIS MANUAL.
- 14 THE EXHAUST SYSTEM SHOULD BE CHECKED TWICE A YEAR MINIMUM FOR ANY BUILD-UP OF SOOT OR CREOSOTE.
- 15 GASOLINE OR OTHER FLAMMABLE LIQUIDS MUST NEVER BE USED TO START THE FIRE OR "FRESHEN UP FIRE". DO NOT STORE OR USE GASOLINE OR OTHER FLAMMABLE VAPORS AND LIQUIDS IN THE VICINITY OF THIS APPLIANCE.
- 16 ASHES MUST BE DISPOSED OF IN A METAL CONTAINER WITH A TIGHT FITTING LID AND PLACED ON A NONCOMBUSTIBLE SURFACE BEFORE FINAL DISPOSAL.
- 17 THIS UNIT MUST BE CONNECTED TO A GROUNDED STANDARD 110 VOLT, 60 HZ ELECTRICAL OUTLET. NEVER ROUTE THE POWER CORD UNDER OR IN FRONT OF THE UNIT.
- 18 DO NOT UNDER ANY CIRCUMSTANCES CUT OR REMOVE THE GROUNDING PRONG FROM THE POWER CORD PLUG.
- 19 DO NOT USE AN ADAPTOR PLUG.
- 20 BEFORE REMOVING PANELS DISCONNECT POWER CORD FROM ELECTRICAL OUTLET. NOTE: TURNING THE CONTROL OFF DOES NOT DISCONNECT THE POWER TO ALL ELECTRICAL COMPONENTS.
- 21 WHEN INSTALLED IN A MOBILE HOME THE UNIT MUST BE GROUNDED TO THE STEEL CHASSIS OF THE MOBILE HOME AND BOLTED TO THE FLOOR IN COMPLIANCE WITH AND ACCORDING TO H.U.D. REQUIREMENTS.
- 22 THE APPLIANCE WILL NOT OPERATE USING NATURAL DRAFT OR WITHOUT A POWER SOURCE FOR THE BLOWERS AND FUEL FEEDING SYSTEM.

TABLE OF CONTENTS Page

Introduction and Important Information	1
Safety Precautions	2
Features and Specifications	4
Preperation for Installation	5
Freestanding Residential Installation	6
Horizontal Corner Installation	8
Vertical Exterior Flue System	9
Inside Vertical Installation with Roof Termination	10
Hearth Stove Installation into Existing Masonry Fireplace	11
Vertical Installation into existing Factory Built Chimney	12
Horizontal Installation	13
Freestanding Mobile Home Installation	14
Freestanding Residential Alcove Installation	15
Location and use of Controls	16
Operating your Pellet Stove	17
Care and Maintenance	18
Maintenance Schedule - 1000 lbs of Fuel Used	20
Maintenance Schedule - 6000 lbs of Fuel Used	21
Before Calling for Service	24
Replacement Parts List	27
Limited Warranty	28

FEATURES AND SPECIFICATIONS

CONVENIENCE

LONG BURN RATE

VERSATILE

CLOSE CLEARANCES

DURABLE

POWERFUL, EFFICIENT BLOWERS

SUPERIOR AUGER SYSTEM

HUGE HOPPER

STAINLESS STEEL FIRE POT

QUIET OPERATION

Heating Capacity SQ/FT	2,500	MAX
CU/FT	20,000	MAX
Maximum BTU'S per Hour	37,500	
Minimum BTU'S per Hour	9,500	
Overall Efficiency	85%	
Emissions Grams/per hour	N/A	(EPA Exempt)
Maximum Burning time (Hours)	50	
Flue Opening Diameter	3"	(75 mm)
Hgt. from floor to top of stove	28.5"	(724 mm)
Overall Width	24"	(610 mm)
Overall depth	27"	(685 mm)
Hopper Capacity (lbs)	60	(27 KG)
Unit Weight (lbs)	260	(118 KG)
Electrical Rating	115 Volts, 3 Amps,	60 HZ

FUEL:

The unit is designed to operate using 1/4 inch diameter pellets that comply with *A.P.F.I. standards. If the fuel does not comply to this standard, the unit may not operate as designed. If the pellets are larger than 1/4 inch diameter the unit may need adjustments, consult with your dealer.

NOTE: Store pellets in a clean dry place.

* Emissions information and efficiency information based on tests conducted in Travis Industries laboratory. All tests were conducted in accordance with Oregon method OM7 standard.

PREPARATION FOR INSTALLATION

PREPARATION:

1. Remove all tape and packaging.
2. Remove the wood shipping frame from around and under the appliance.
3. Check that no parts have become loose and the appliance has not been damaged during shipping.
4. Remove the hardware pack from the appliance.
5. READ THE OWNERS MANUAL BEFORE PROCEEDING.

• Appliance should be located such that no doors, drapes, furniture or other combustibles can be placed closed or swung closer than minimum stated clearances.

• The appliance must be installed in a level, secure position.

• Required floor protection

Min size 24" W x 33" D - (610 mm W x 850 mm D)
except inside vertical
installation refer figure 6

Front - 6" (150 mm)

Sides - 0" (0 mm)

Back - 0" (0 mm)

NOTE: Area beneath flue vent pipe must be protected.

• Maximum Chimney Length

33' Vertical (10.06 m)

10' Horizontal (3.05 m)

• Minimum Chimney Length

6' Vertical (1830 mm)

2' Horizontal (610 mm)

• Do not obtain combustion air from attic, garage, unventilated crawl space or any other enclosed space. Do not locate combustion air inlet at an elevation higher than exhaust termination.

• Outside Air (combustion air intake) is required for all installations. Please consult with your local building officials before installing your pellet fired appliance.

• The Outside Air Intake (Combustion Air Intake) must be connected to a 1 3/4" I.D. metal or aluminum duct with rodent screen fixed to the termination.

• The 400 - PS pellet fired appliance vent collar accepts 3" diameter pellet vent. The brands for use with the 400 - PS are:

1. Duravent Model PL-Vent
Simpson Dura-Vent
P.O. Box 1510
Vacaville, CA 95688
(707) 446-1786 or
1-800-227-8846

2. James A. Ryder MFG Model PL-Vent
Ryder Mfg., Inc.
241 Arvin Avenue
Stoney Creek, Ontario Canada
(416) 662-1701

See manufacturer's installation instructions for precautions required for passing vent through a combustible wall or ceiling. Do not connect this appliance to a vent serving another appliance.

All sections of pellet vent must be fastened to each other with sheet metal screws and silicone sealed with type 500 degrees F RTV silicone sealer, to ensure that the joints are airtight.

FREESTANDING RESIDENTIAL INSTALLATION

LOCATION OF EXHAUST VENT AND OUTSIDE COMBUSTION AIR INTAKE

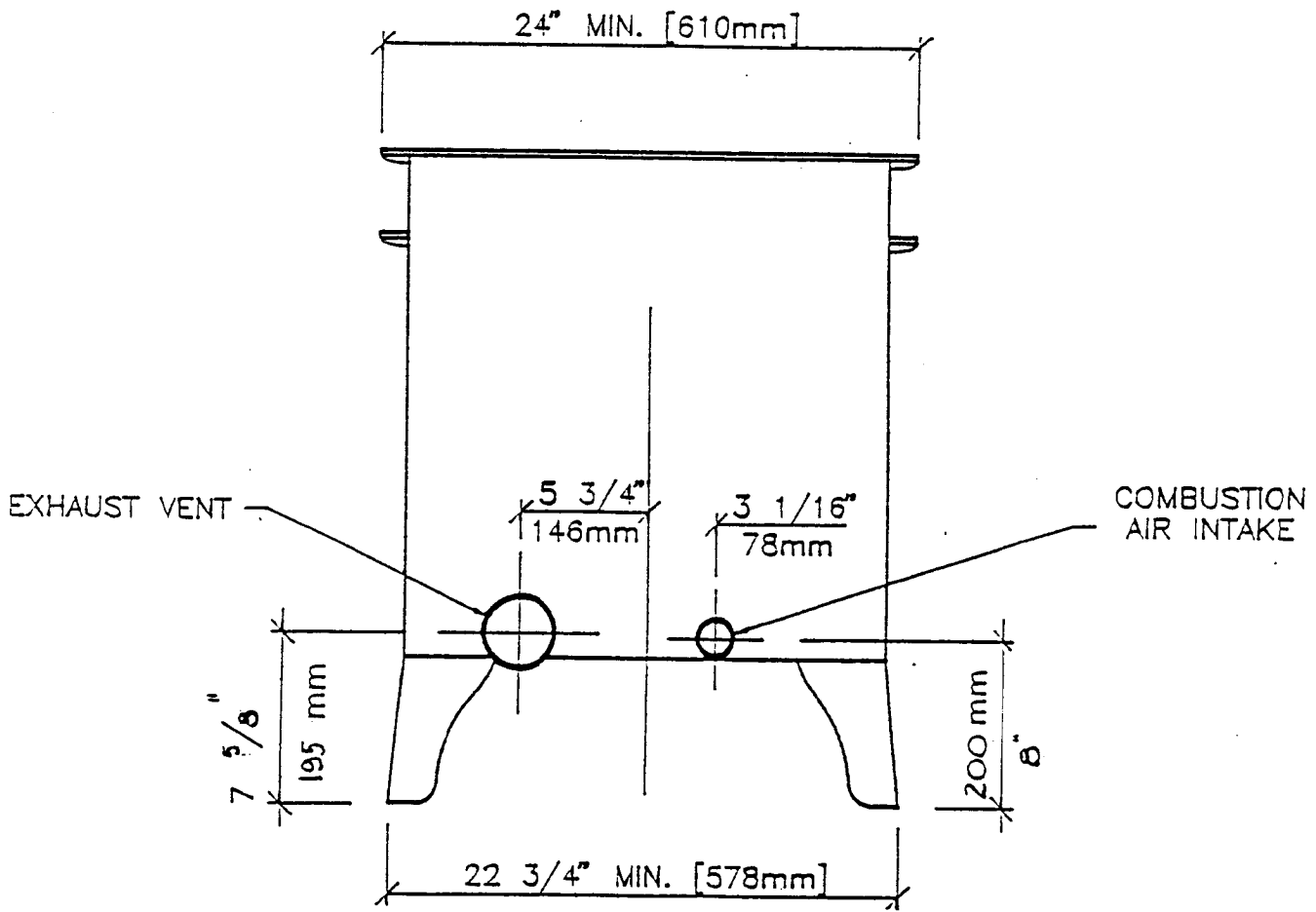

FLOOR PROTECTION
Figure #2

- G - Front - 6" - (150 mm)
- H - Sides - 0" - (0 mm)
- H - Back - 0" - (0 mm)

NOTE: Floor protector should extend to areas below flue vent pipe and 2" (50 mm) to each side of vent pipe.

CLEARANCE TO COMBUSTIBLES

INTERIOR VERTICAL
FLUE INSTALLATION
Figure 2 & 3

A Left side wall to unit	8" - (200 mm)
B Right side wall to unit	8" - (200 mm)
C Backwall to unit	11" - (280 mm)
D Corner to unit	2" - (50 mm)
E Flue vent/chimney	3" - (75 mm)

HORIZONTAL THROUGH
THE WALL INSTALLATION OR VERTICAL EXTERIOR INSTALLATION
Figure 2 & 3

A Left side wall to unit	8" - (200 mm)
B Right side wall to unit	8" - (200 mm)
C Backwall to unit	3" - (75 mm)
D Corner to unit	2" - (50 mm)
E Flue vent/chimney	3" - (75 mm)

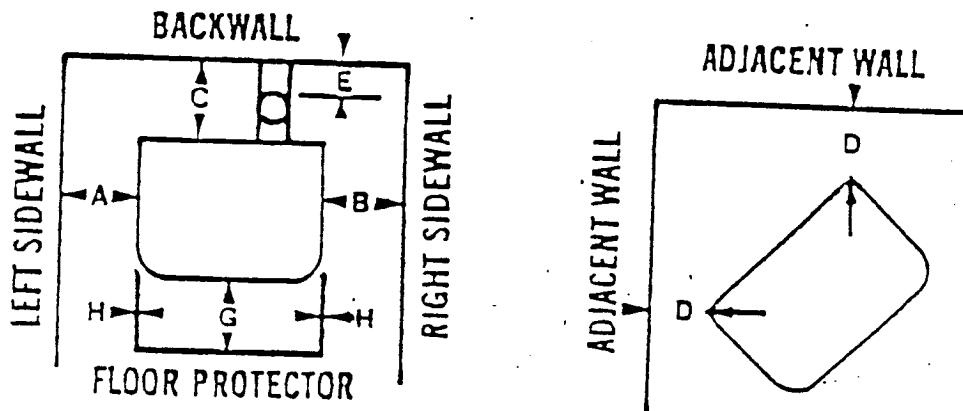

Figures #2 & 3

HORIZONTAL CORNER INSTALLATION

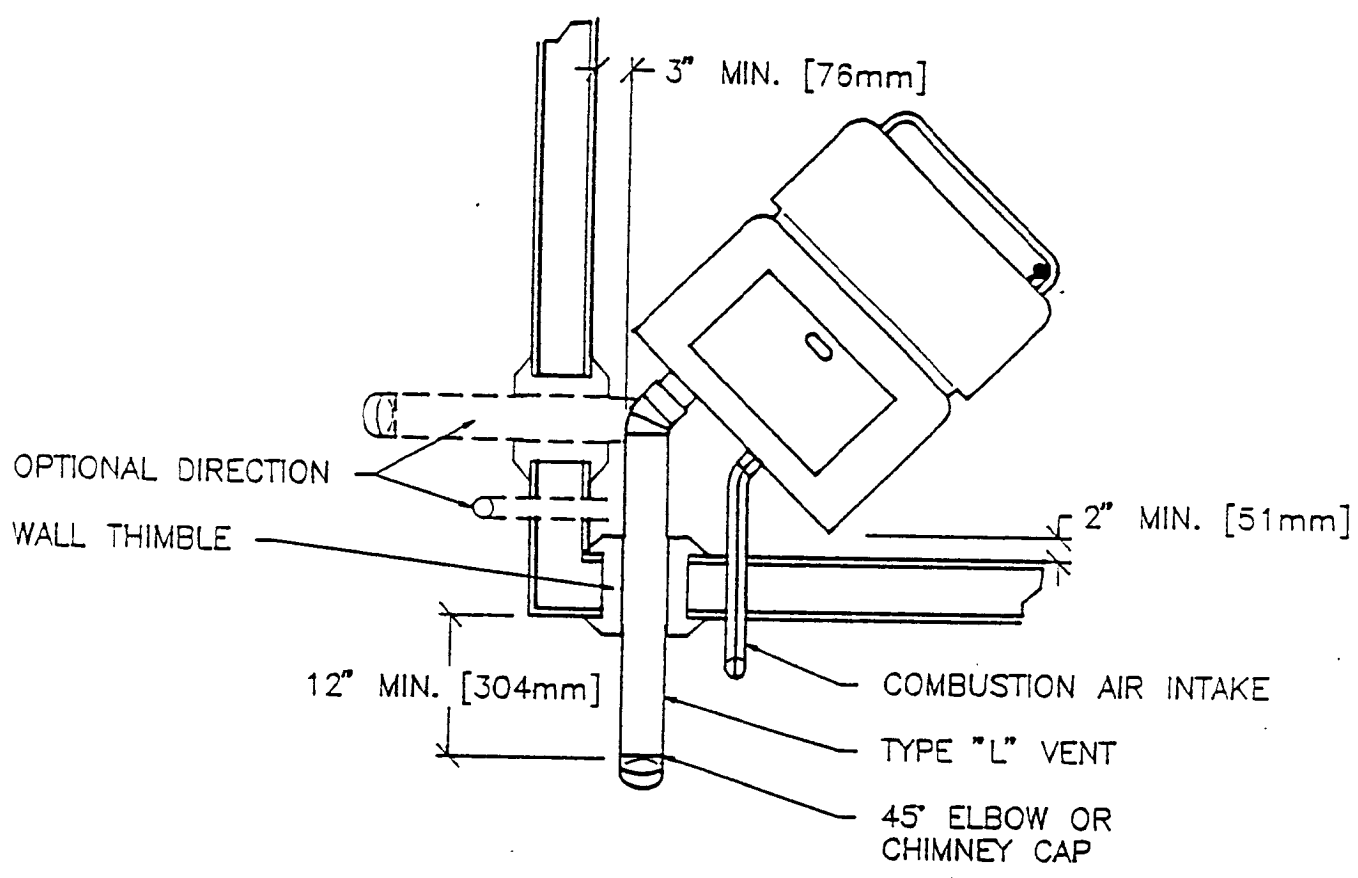

Figure #4

Horizontal or vertical exhaust vent terminations shall be located not less than four feet (4 ft) (1220 mm) below, four feet (4 ft) (1220 mm) horizontally from, or one foot (1 ft) (305 mm) above any door, window, or gravity air inlet into any building, nor less than two feet (2 ft) (610 mm) from an adjacent building, nor less than seven feet (7 ft) (2130 mm) above grade when located adjacent to public walkways. Termination should be at least two feet (2 ft) (610 mm) above grass, plants or other combustible surfaces.

VERTICAL EXTERIOR FLUE SYSTEM

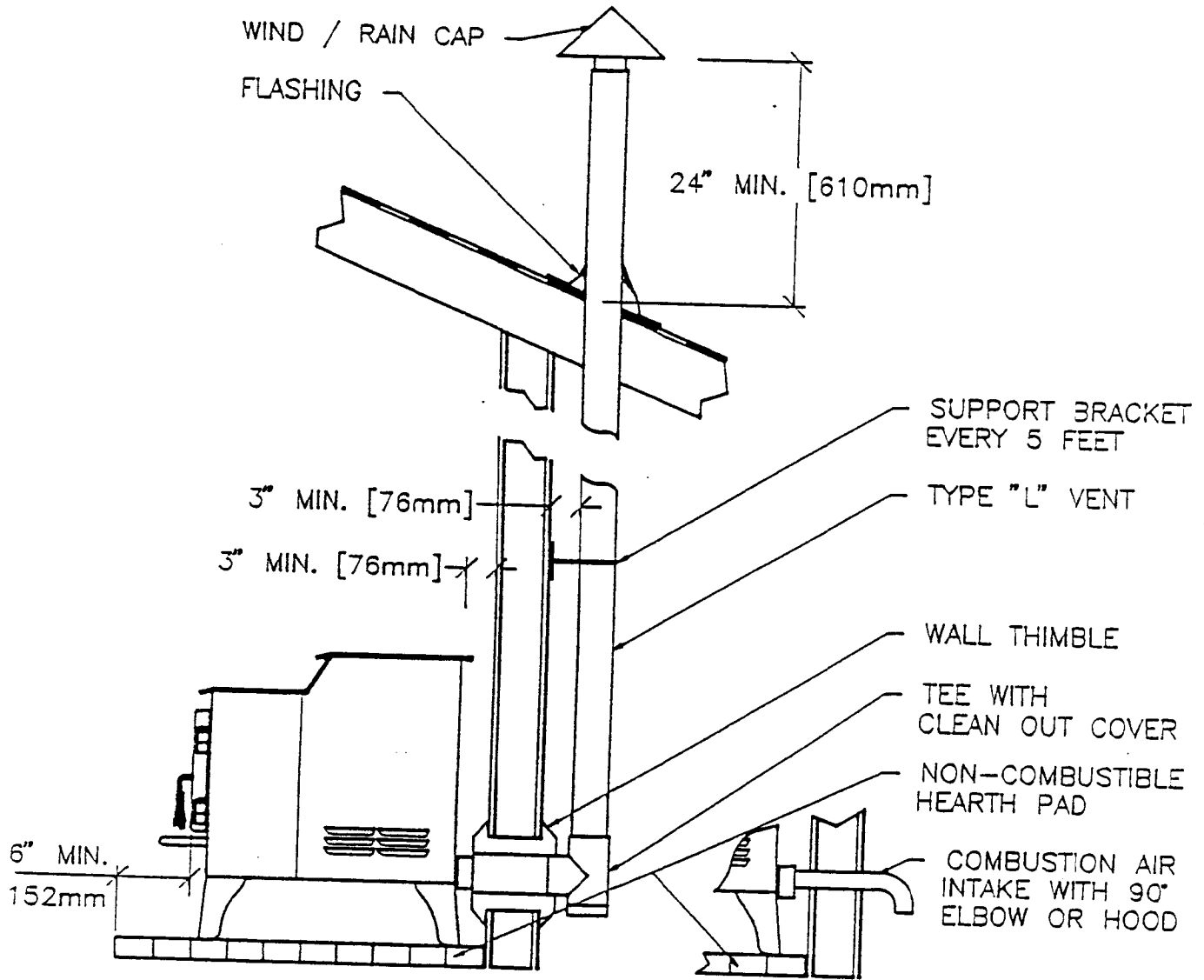

FIGURE #5

Horizontal or vertical exhaust vent terminations shall be located not less than four feet (4 ft) (1220 mm) below, four feet (4 ft) (1220 mm) horizontally from, or one foot (1 ft) (305 mm) above any door, window, or gravity air inlet into any building, nor seven feet (7 ft) (2130 mm) above grade when located adjacent to public walkways. Termination should be at least two feet (2 ft) (610 mm) above grass, plants or other combustible surfaces.

INSIDE VERTICAL INSTALLATION WITH ROOF TERMINATION

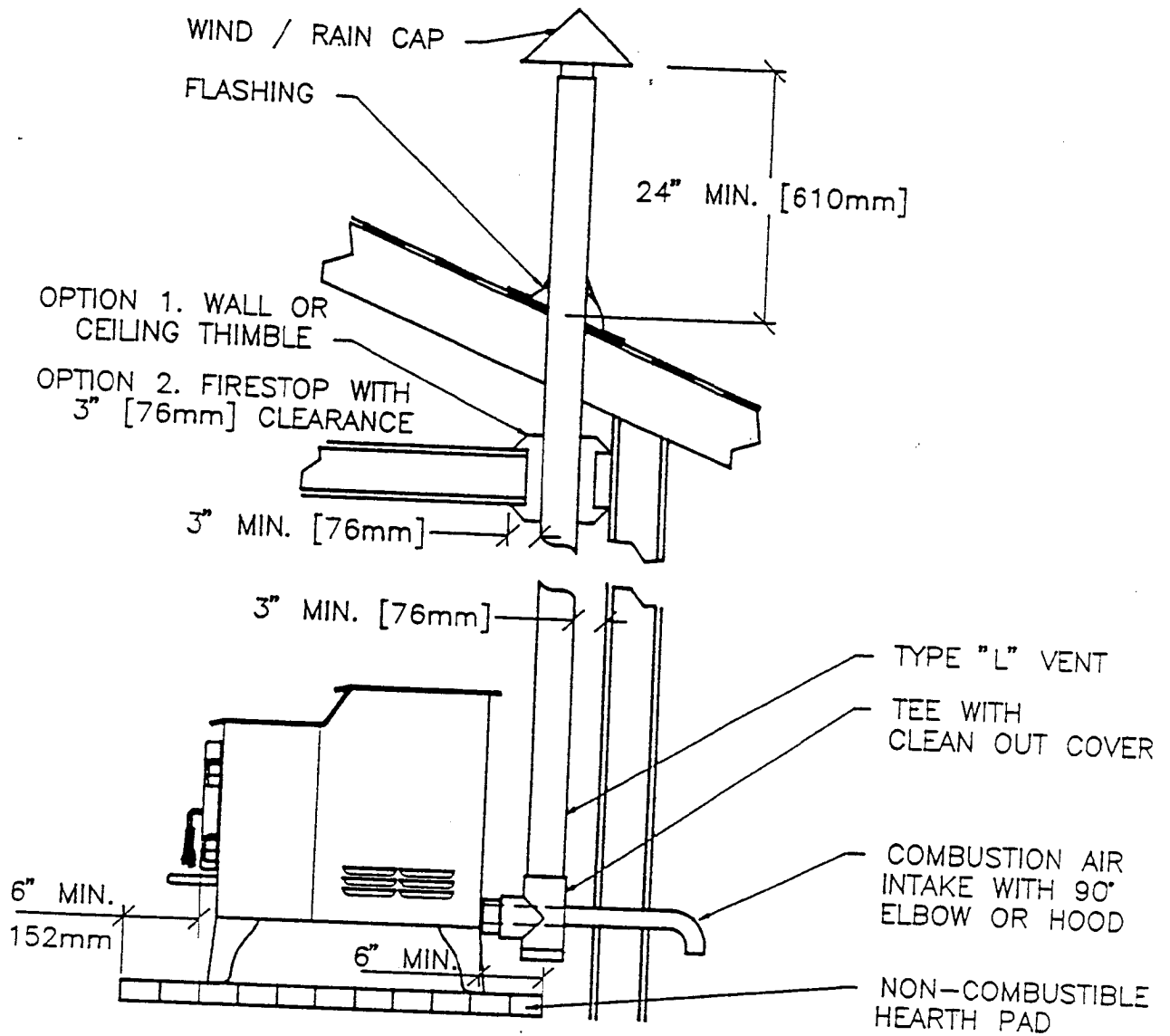

Figure #6

Horizontal or vertical exhaust vent terminations shall be located not less than four feet (4 ft) (1220 mm) below, four feet (4 ft) (1220 mm) horizontally from, or one foot (1 ft) (305 mm) above any door, window, or gravity air inlet into any building, nor less than two feet (2 ft) (610 mm) from an adjacent building, and less than seven (7 ft) (2130 mm) above grade when located adjacent to public walkways. Termination should be at least two feet (2 ft) (610 mm) above grass, plants or other combustible surfaces.

HEARTH STOVE INSTALLATION INTO EXISTING MASONRY FIREPLACE

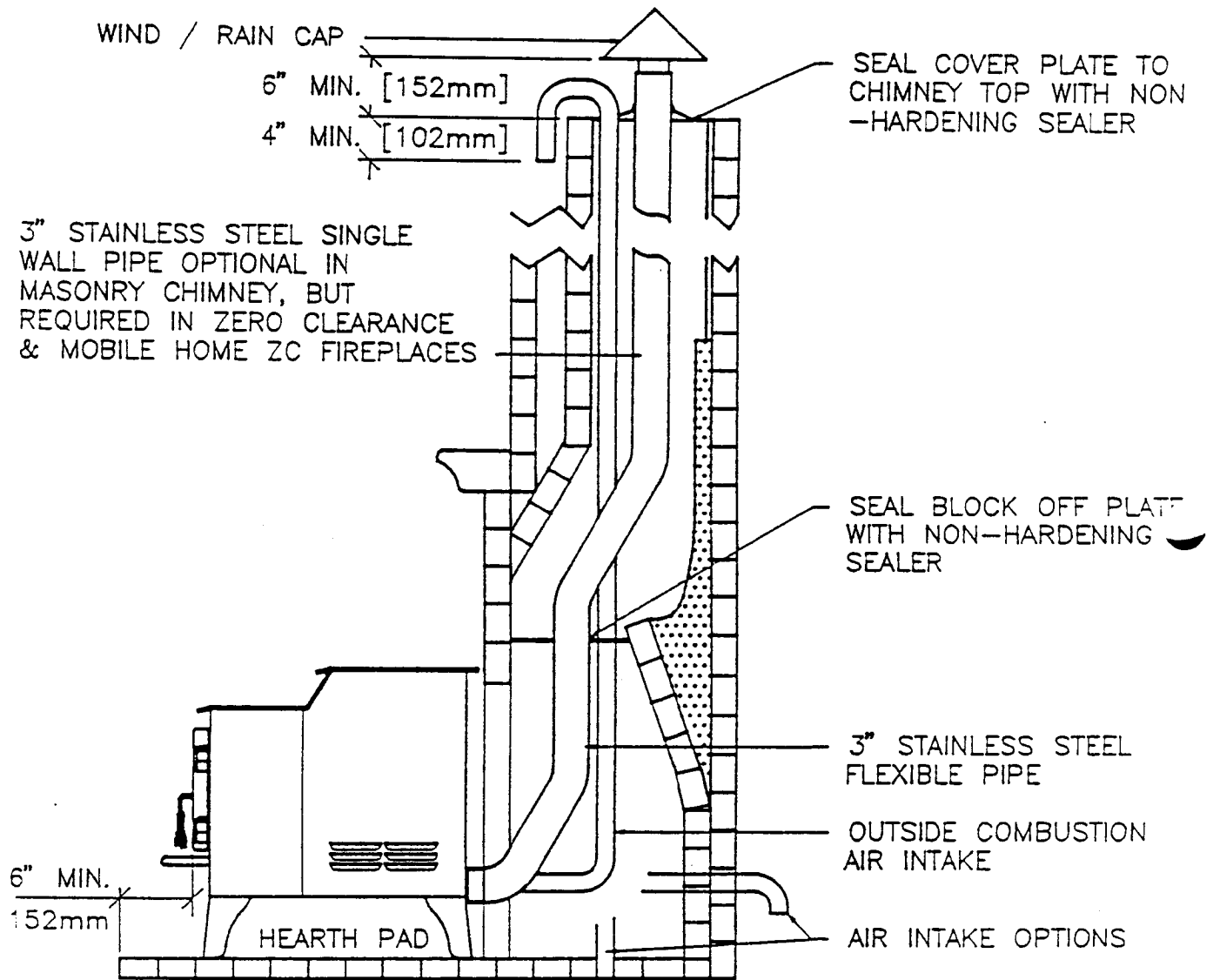

Figure #7

Horizontal or vertical exhaust vent terminations shall be located not less than four feet (4 ft) (1220 mm) below, four feet (4 ft) (1220 mm) horizontally from, one foot (1 ft) (305 mm) above any door, window, or gravity air inlet into any building, nor less than two feet (2 ft) (610 mm) from an adjacent building, and less than seven feet (7 ft) (2130 mm) above grade when located adjacent to public walkways. Termination should be at least two feet (2 ft) (610 mm) above grass, plants, or other combustible surfaces.

VERTICAL INSTALLATION INTO EXISTING FACTORY BUILT CHIMNEY

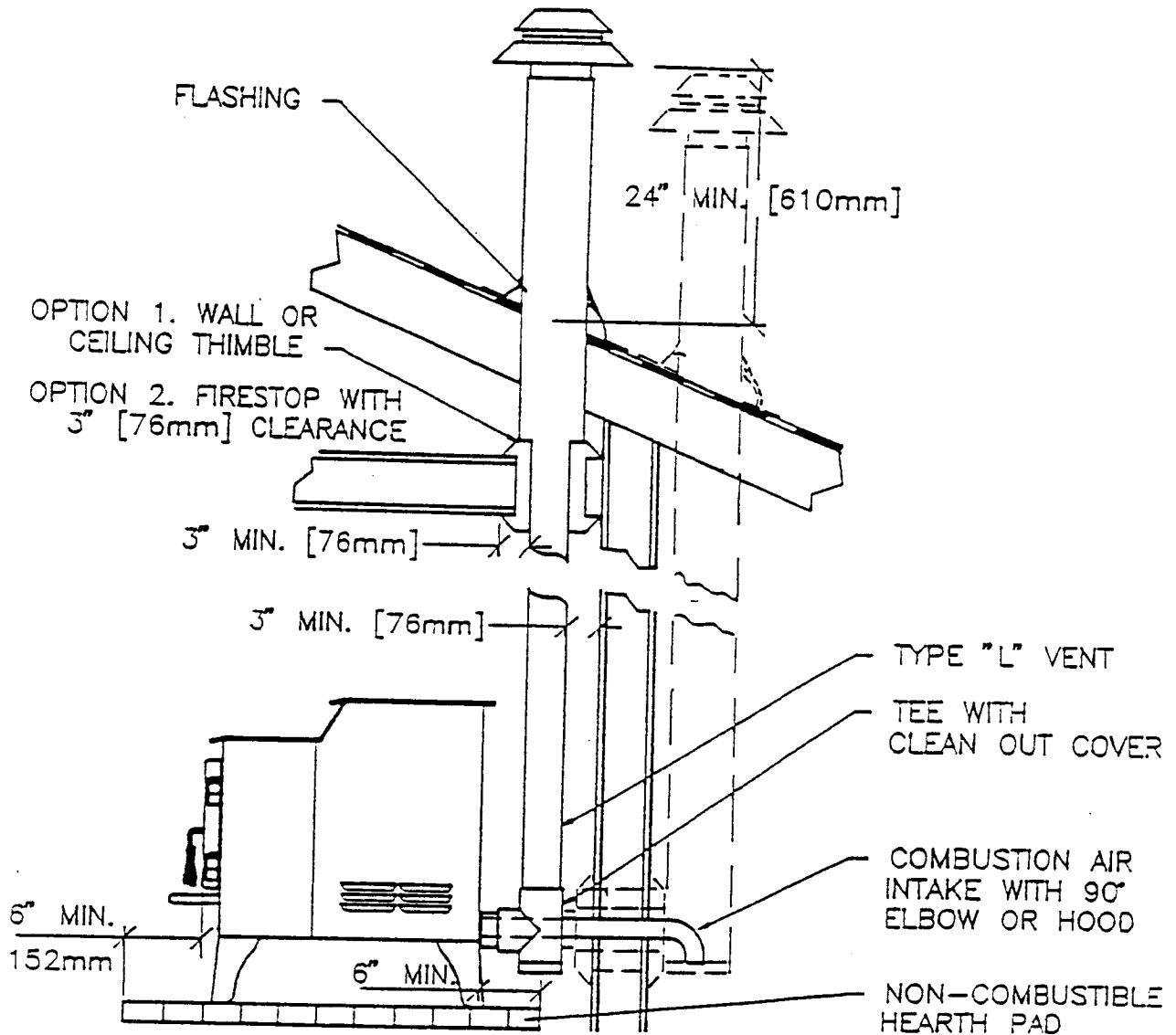

Figure #8

Horizontal or vertical exhaust vent terminations shall be located not less than four feet (4 ft) (1220 mm) below, four feet (4 ft) (1220 mm) horizontally from, or one foot (1 ft) (305 mm) above any door, window, or gravity air inlet into any building, nor less than two feet (2 ft) (610 mm) from an adjacent building, and less than seven feet (7 feet) (2130 mm) above grade when located adjacent to public walkways. Termination should be at least two feet (2 ft) (610 mm) above grass, plants or other combustible surfaces.

HORIZONTAL INSTALLATION

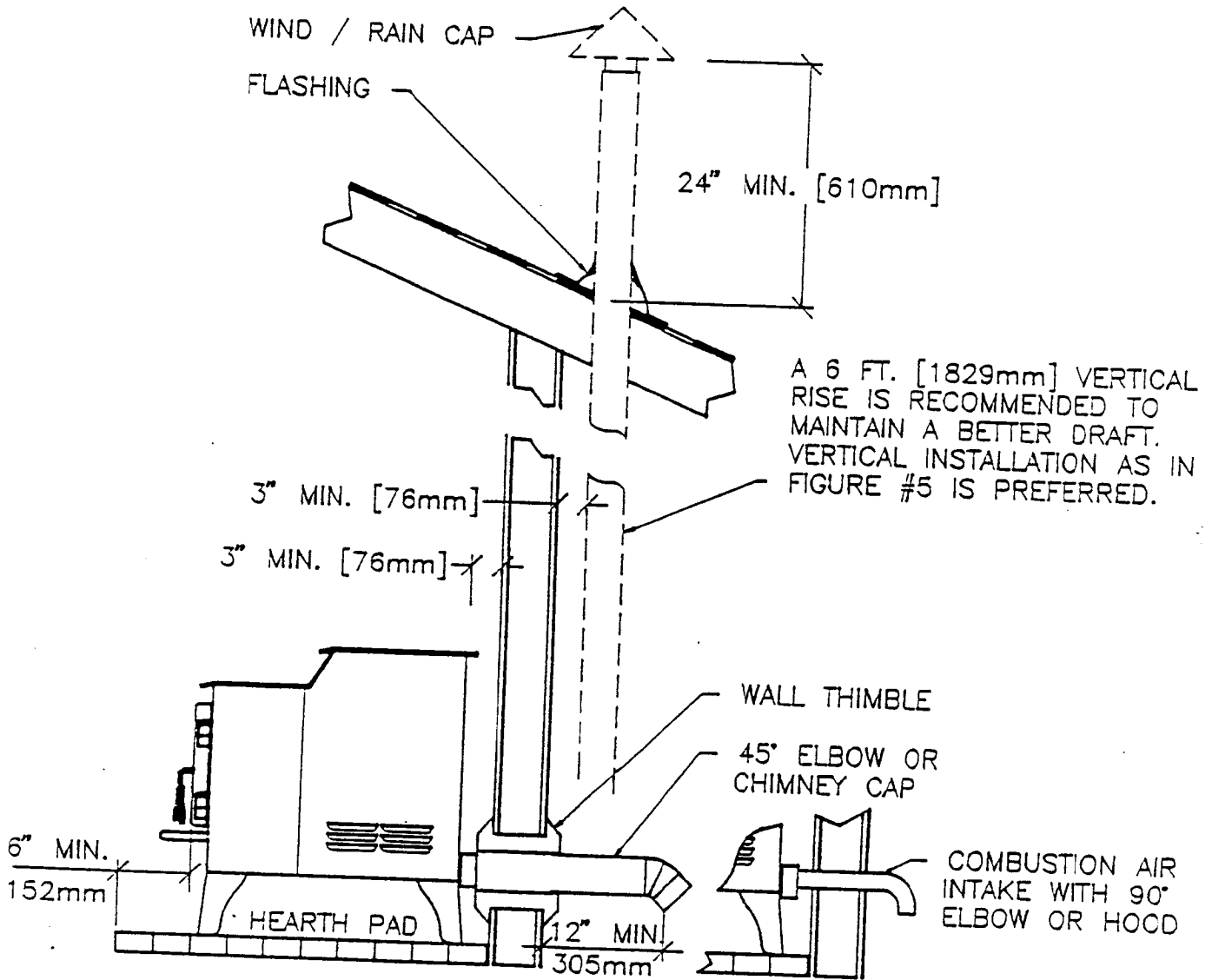

Figure #9

Horizontal or vertical exhaust vent terminations shall be located not less than four feet (4 ft) (1220 mm) below, four feet (4 ft) (1220 mm) horizontally from, one foot (1 ft) (305 mm) above any door, window, or gravity air inlet into any building, nor less than two feet (2 ft) (610 mm) from an adjacent building, and less than seven feet (7 ft) (2130 mm) above grade when located adjacent to public walkways. Termination should be at least two feet (2 ft) (610 mm) above grass, plants, or other combustible surfaces.

FREESTANDING MOBILE HOME INSTALLATION

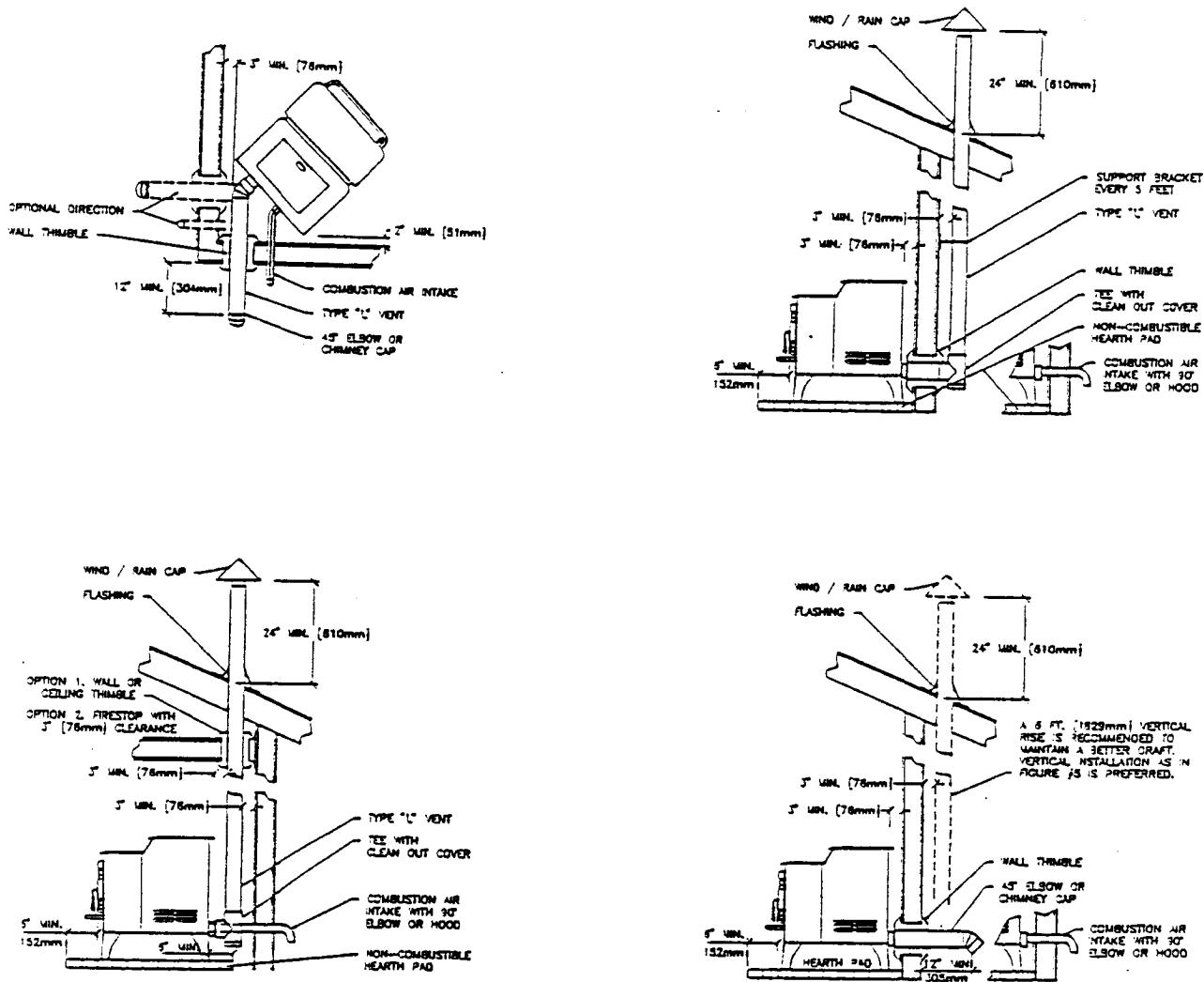

Figure #10

CAUTION: The structural integrity of the mobile home floor, wall & ceiling roof must be maintained.

In addition to the FREESTANDING RESIDENTIAL INSTALLATION requirements, the following requirements are mandatory for installation into a mobile home:

1. The stove must be permanently bolted to the floor of the mobile home.
2. Stove must have permanent outside air (combustion air) intake.
3. Stove must be grounded to the steel chassis of the mobile home.

FREESTANDING RESIDENTIAL ALCOVE INSTALLATION

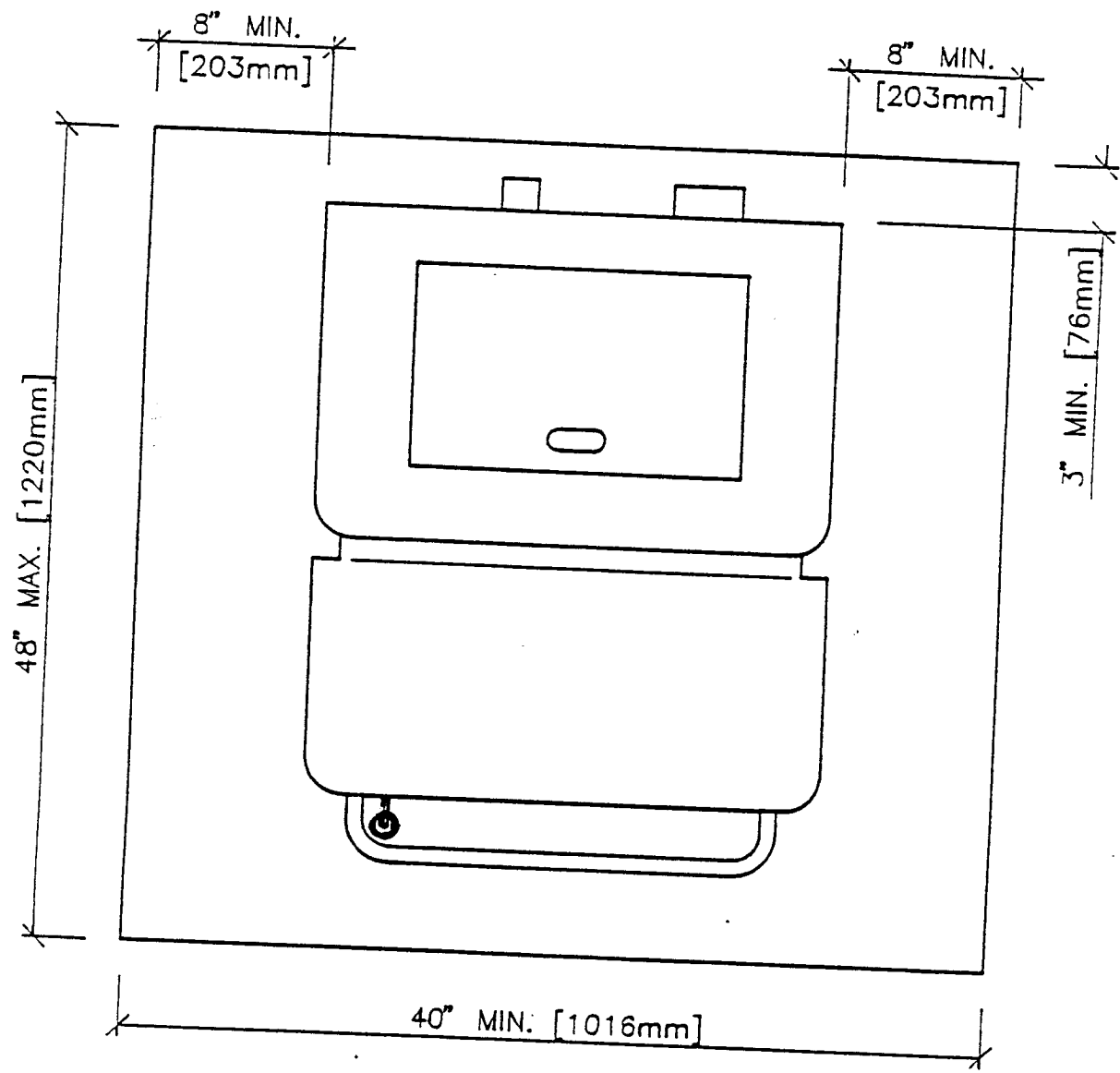
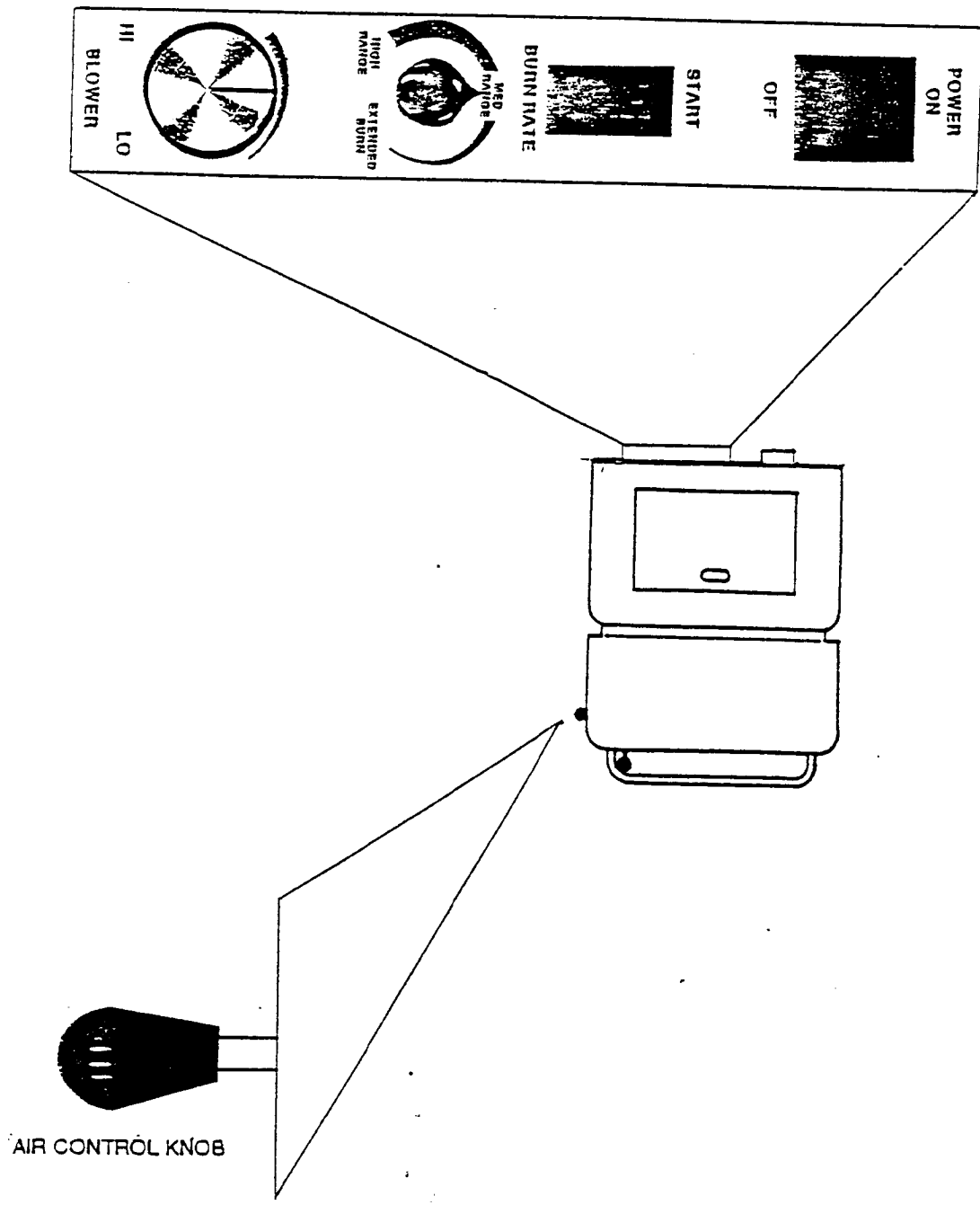

Figure #11

MINIMUM ALCOVE HEIGHT 60" - (1525 mm)
MAXIMUM ALCOVE DEPTH 48" - (1220 mm)

LOCATION AND USE OF CONTROLS



OPERATING YOUR PELLETS STOVE

1. RECOMMENDED FUEL TYPES & SIZES

The unit is designed to operate using 1/4 inch pellets that comply with A.P.F.I.* standards. If the fuel does not comply to this standard the unit may not operate as designed. If the pellets are larger than 1/4 inch diameter the unit may need adjustments. Consult with your dealer.

* A.P.F.I. Association of Pellet Fuel Industries.

NOTE: Store pellets in a clean dry place.

2. PRIMING THE AUGER:

Priming the auger is only required when the unit is new or when the hopper has completely run out of pellets.

- Load the hopper with pellets.
- Set the burn rate control knob to "HIGH RANGE".
- Switch the power switch to "ON".
- Press the start switch and release when indicating light comes on.

This will start the auger and begin the priming process. Once pellets are feeding into the burn pot turn the power switch "OFF". You are now ready to start a fire.

3. STARTING YOUR APPLIANCE:

- Open the door and place a wax-impregnated wood fire starter in the center of the burn pot and light. When the fire starter is burning, close the door.
- Push the black "AIR CONTROL KNOB" to the closed position. (Located on the lower left side of the unit.) Press the power switch "ON". Adjust the burn rate control to the "EXTENDED BURN" position and press the start switch. (The amber indicator light will come on.) Pellets will begin to feed into the burn pot.
- Once the pellets are burning and you have established a fire, set the burn rate at the "HIGH RANGE" position. Then pull the black "AIR CONTROL KNOB" out to the open position.
- Before turning the unit to a lower burn setting it is necessary to run the unit on "HIGH RANGE" after a fire has been established for at least 15-20 minutes. This allows the unit to reach proper operating temperature. Failure to do this could result in an inadequate operating temperature and the unit will turn itself off. If this happens you will have to repeat the entire start - up procedure.

4. RUNNING YOUR APPLIANCE:

- Burn rate control and air control settings for normal operation:

When the burn rate setting is set on:

- "HIGH RANGE", Air Control setting is full out position "OPEN"
- "MEDIUM RANGE", Air Control setting is between full "CLOSED" and "OPEN"
- "EXTENDED BURN", Air Control setting is full in position "CLOSED"

- The Air Control knob settings for your unit could vary due to type and quality of fuel used. Therefore, it is suggested that you establish the settings that best suit your particular fuel needs. This is done by adjusting the air control knob "OPEN" or "CLOSED" to allow more or less combustion air to increase or decrease the rate of burn.

5. TURNING THE UNIT OFF:

- Turn the power switch to the "OFF" position. The unit will automatically turn the convection and combustion blowers off when the temperatures have reached the shut down range.

6. AUTOMATIC SAFETY FEATURES:

A. POWER OUTAGES

During a power outage the unit will shut itself down safely. It will not restart unless there is sufficient fire pot temperature to sustain combustion.

B. OVERHEATING

This unit is equipped with an overheat sensor. If the unit becomes overheated it will shut itself down safely. The appliance will not restart until it has cooled to a safe level. It may be necessary to restart the unit if this occurs. If this happens frequently, turn the unit off and consult with your dealer to determine the problem.

C. BLOCKED FLUE OR DOWN DRAFT PROTECTION

This unit is equipped with a draft flow switch. If a draft restriction or down draft occurs, the unit will automatically shut itself off. If the restriction or down draft is temporary, it will automatically resume operation. If not, you will need to locate the restriction and correct it before restarting your unit.

1000 Pounds of Fuel Used Maintenance

There are several areas and parts of the unit that should be inspected and cleaned after every 1000 pounds of fuel used, these are: (See Figure 12)

- A. Firepot
- B. Fly-ash trap behind the refractory.
- C. Ashpan
- D. Heat exchanger tubes.
See Figure 15

6000 Pounds of Fuel Used Maintenance

The following areas should be inspected, cleaned and serviced after every 6000 pounds of fuel used.

- E. Draft Induction Blower
- F. Convection Blower
- G. Auger Motor
- H. Auger tube and hopper area
- I. Chimney system
- J. Door gaskets
- K. Ashpan gaskets

NORMAL OPERATING SOUNDS

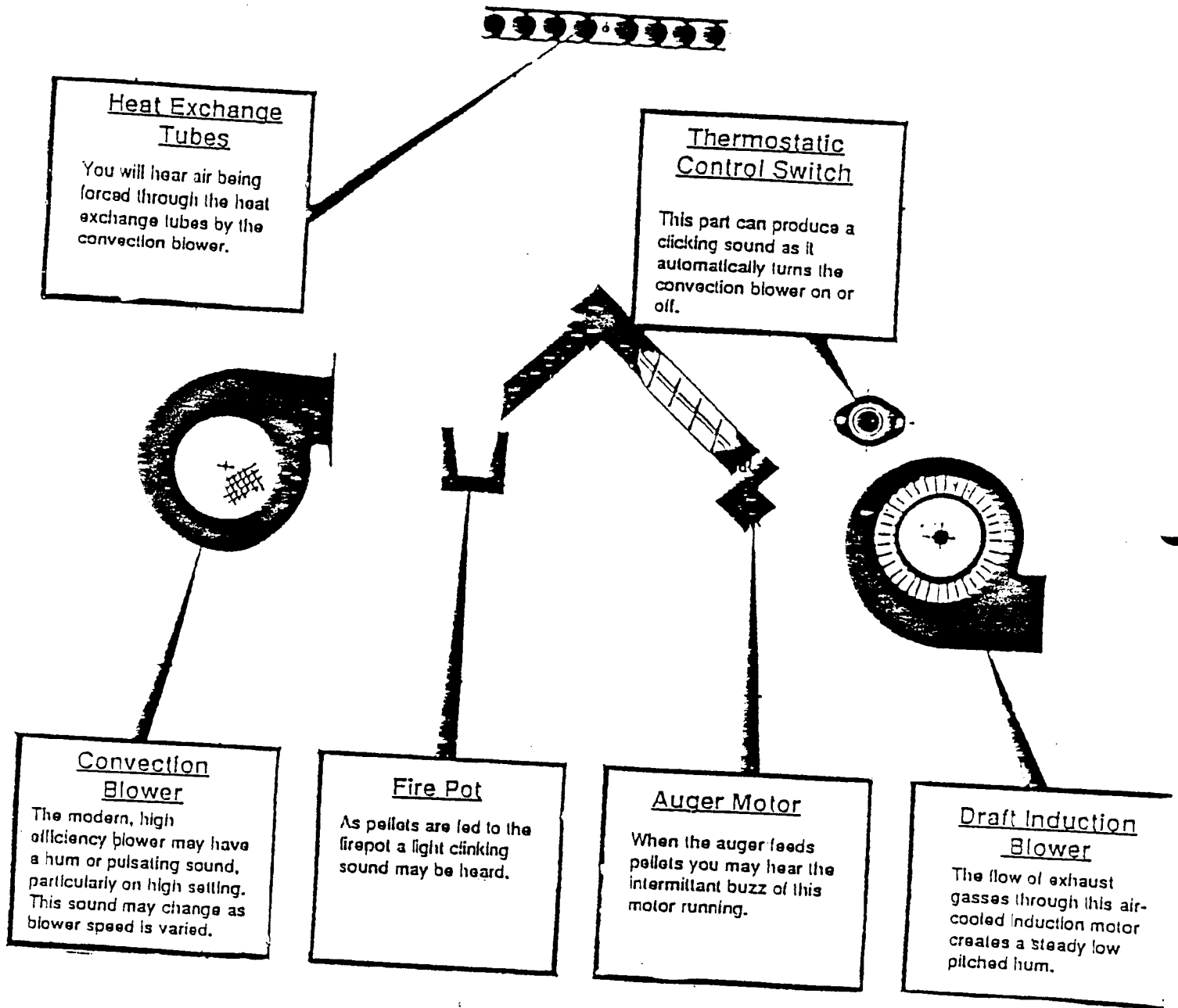

Maintenance Schedule - 1000 lbs of Fuel Used

Prior to carrying out routine maintenance, ensure the appliance has cooled down sufficiently to handle the parts with safety.

Part	Tools Required	Procedure
Firepot	Stiff Brush	To inspect and clean firepot, remove the entire assembly as shown in figures 13 and 14. Using a stiff brush, clean all the deposits from the firepot grate. When this is completed, clean the firepot of all flyash. NOTE: Regularity of firepot cleaning is subject to the quality of fuel being used.
Fly-ash Trap behind Refractory	Metal Scraper Stiff Brush 5/16" Wrench	Brush the visible fly-ash from the bottom of the firebox into the ashpan. Remove the flame deflector using a 5/16" wrench. Remove the refractory, starting with the center section, then each side. Clean the fly-ash trap area using a metal scraper and brush ash into the ashpan. Remove the ashpan and dispose of the fly-ash in a safe manner.
Heat Exchanger Tubes	Built - in Scraper (See figure 15)	After cleaning tubes with the built - in scraper, brush all the fly-ash into the ashpan. Remove ashpan and dispose of fly-ash in a safe manner
<p>NOTE: Inspect the gaskets on the door, glass and ashpan. If they show signs of deterioration, replace them. See your dealer for the proper type and size of gaskets.</p>		

Maintenance Schedule - 6000 lbs of Fuel Used

Prior to carrying out routine maintenance, ensure the appliance has cooled down sufficiently to handle the parts with safety.

NOTE: We recommend that this service be done by an authorized pellet stove technician.

PREPERATION FOR 6000 LB MAINTENANCE:

- 1) Unplug the unit and disconnect the exhaust and inlet connections at the rear of the appliance.
- 2) Remove all of the pellets from the hopper. (It will be easier if you let your unit run out.) Using a heavy-duty vacuum, clean the hopper and auger tube opening of all sawdust and fines.
- 3) Repeat the 1000 lbs maintenance schedule.

Part	Tools Required	Procedure
Remove Side Panels	1/8" Allen Wrench 1/4" Wrench	Loosen set screws with allen wrench. Remove the sheet metal screws with the 1/4" wrench. (See Figure 16).
Remove Exhaust Insulator and Draft Induction Blower	5/16" Nut Driver Vacuum Cleaner Soft Brush	Remove the insulator surrounding the exhaust tube. Disconnect the draft induction blower electrical leads. Using the 5/16" nut driver, remove the three blower mounting bolts. Remove the blower, complete with the exhaust tube, from the appliance. (See figure 17). When the blower has been removed, inspect the impeller blades and housing. Clean all the fly-ash from these areas using a soft brush and vacuum cleaner. Prior to replacing the blower assembly, check that the silicone seal at the blower and exhaust tube connection has not fractured. If necessary, use Type RTV 500 degree F silicone sealant to reseal the joint. Lubricate the combustion and convection blowers with a few drops only of high-grade turbine oil. (Andreal 402) (See figures 18 & 19).
Combustion Air Duct	Vacuum Cleaner	Clean the combustion air duct using vacuum.
Chimney System		Check the chimney system for soot and creosote build-up, and have it cleaned by a certified chimney sweep, if necessary.
Replace the Draft Induction Blower	5/16" Nut Driver	Reverse removal procedure.
Replace Side Panels	1/8" Allen Wrench 1/4" Wrench	Reverse removal procedure.

GLASS MAINTENANCE

Should soot or creosote deposits occur on the glass during operation, clean when the stove is cold with a non-abrasive glass cleaner.

If the glass should break wait until the stove and glass is cool before removing. Do not leave the fire unattended during this cool down period as sparks could escape through the broken glass. Do not operate appliance with broken glass.

To replace the glass, simply remove the door and unscrew the glass retainer. Replace the broken glass with only a400 - PS glass kit, available at all authorized LOP! Dealers. The replacement glass is high temperature, high shock glass of Technical Neoceram(R) (5 mm thick). Under normal operating conditions the glass will not break.

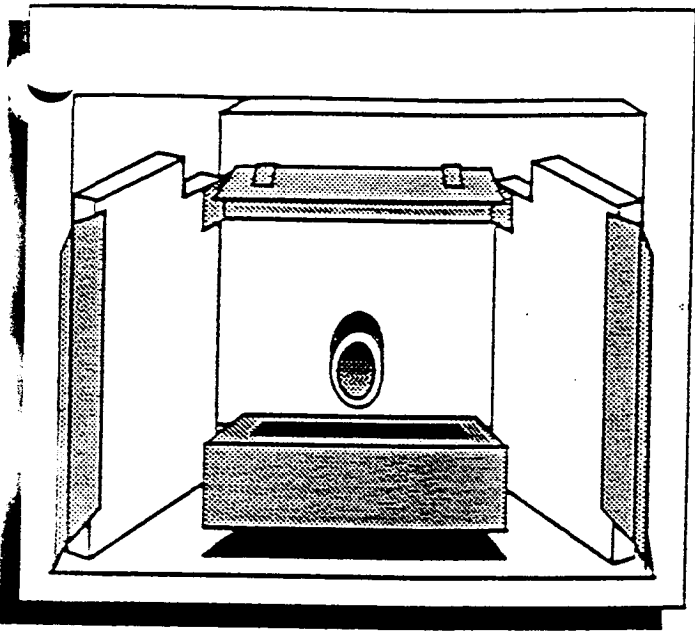

FIGURE 13

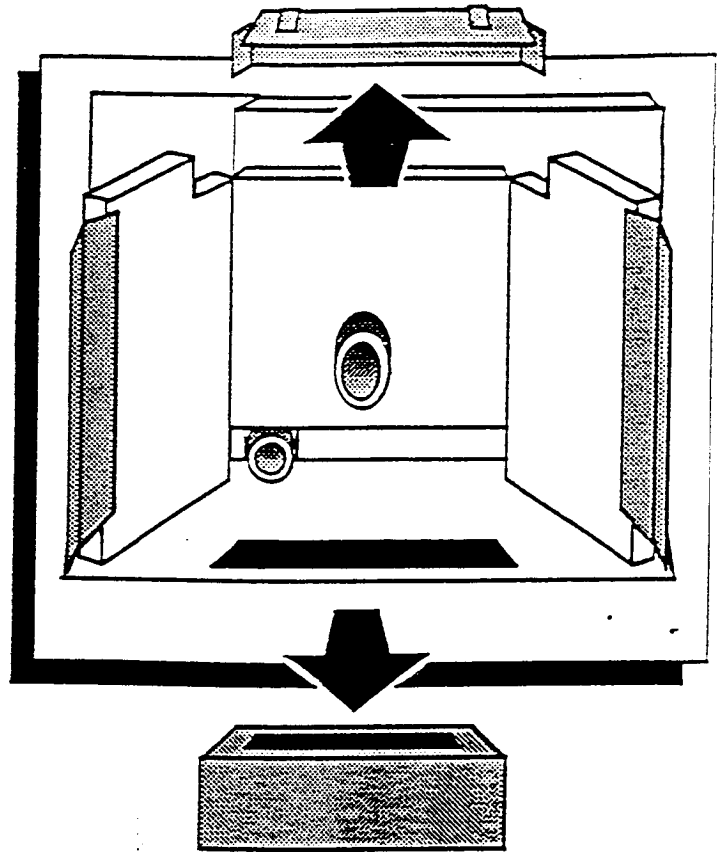

FIGURE 14

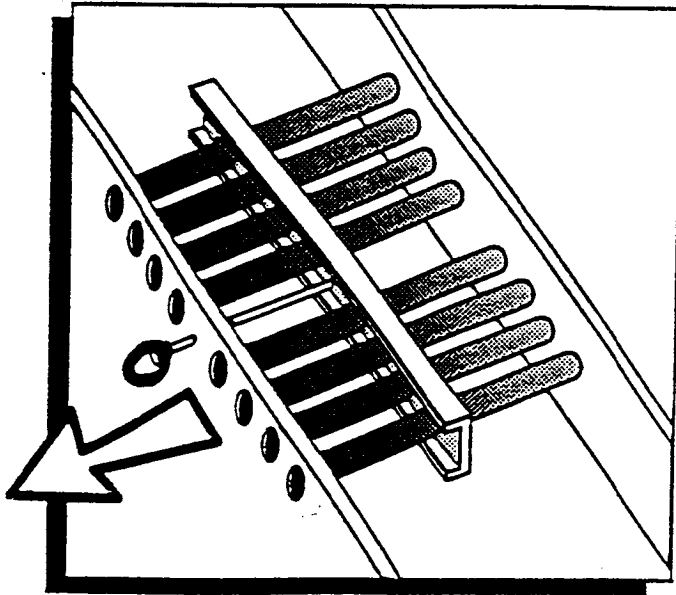

FIGURE 15

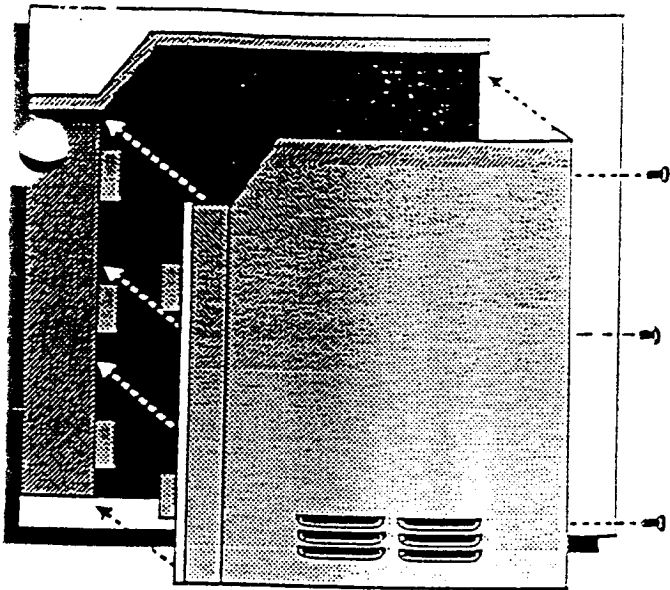

FIGURE 16

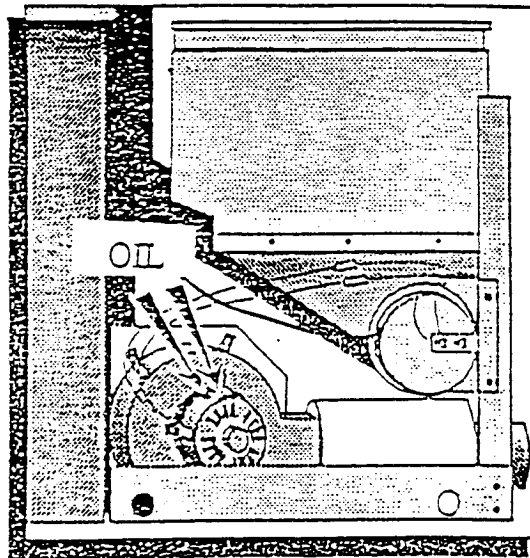

FIGURE 17

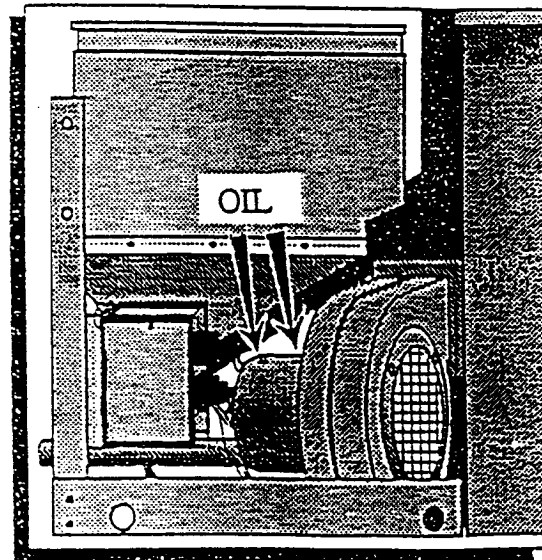

FIGURE 18

NOTE: FIGURE 19 DELETED

BEFORE CALLING FOR SERVICE

SAVE TIME AND MONEY - CHECK THIS LIST BEFORE YOU CALL FOR SERVICE.

To eliminate unnecessary service calls, first read all the instructions in this manual carefully. The following checklist provides possible solutions to common occurrences that are not the result of defective workmanship or materials in this appliance. Always make sure unit is plugged in and that circuit breaker has not tripped.

If you do have a problem that you cannot fix yourself, call your dealer where you purchased your appliance. When calling, have this manual handy with the model, serial number and purchase date of your appliance.

Problem	Possible Cause	Don't Call for Service Until You Check
<p>Firepot overfills on startup.</p> <p>Startup fire extinguishes itself.</p>	<p>Starting appliance on "HIGH BURN" range.</p> <p>Combustion air inlet blocked.</p> <p>Door Ajar.</p> <p>Ashpan open.</p> <p>Firepot not in correct position.</p> <p>Lack of ignition.</p>	<p>Burn rate control is on low burn and air control is closed.</p> <p>Inlet tube is not blocked outside house.</p> <p>Door is latched securely.</p> <p>Ashpan is latched and sealed.</p> <p>Firepot is in correct position and sealed to refractory.</p> <p>Firestarter has not extinguished.</p>
<p>Lazy Orange Flame or Smoking Exhaust</p>	<p>Restriction in combustion intake tube.</p> <p>Air leak in firebox.</p> <p>Firepot Plugged.</p>	<p>Combustion tube intake is not blocked.</p> <p>Door and ashpan are latched.</p> <p>Firepot needs cleaning.</p>

BEFORE CALLING FOR SERVICE

(Continued)

Problem	Possible Cause	Don't Call for Service Until You Check
	<p>Incorrect air control setting.</p> <p>Combustion air duct restricted.</p> <p>Fuel.</p> <p>Power outage.</p> <p>Restricted Exhaust.</p>	<p>Air control is set to suit burn rates. (Open control until fire brightens up.</p> <p>Fly - ash buildup behind refractory.</p> <p>Poor quality fuel.</p> <p>Restart unit.</p> <p>Clean Vent Pipe.</p>
Fire smolders.	<p>Firepot overfilled.</p> <p>Pellets are wet.</p>	<p>Refer to previous check items.</p> <p>Pellets in hopper are dry and all stored pellets are dry.</p>
Pellets not feeding.	<p>Auger not primed.</p> <p>Hopper empty.</p> <p>Power switch not pressed.</p> <p>Start switch not pressed.</p> <p>Appliance not plugged into power outlet or no power available at outlet.</p>	<p>Prime auger</p> <p>Fill hopper.</p> <p>Power switch is pressed and amber indicating light is lighted.</p> <p>Start switch is "on".</p> <p>Appliance is plugged into outlet.</p> <p>Circuit breaker or fuse has not tripped.</p>

BEFORE CALLING FOR SERVICE

(Continued)

Problem	Possible Cause	Don't Call for Service Until You Check
Smoke smell in house and unit has gone off	Intermittant power failure has shut unit off. Automatic safety feature has shut unit off. Unit was unplugged while under full operation.	Power is on. Wait 1/2 hour and relight. If unit won't light, consult your dealer. See page 17.
Unit has shut off and hopper is full of pellets.	Automatic safety feature has shut unit off.	See page 17.

REPLACEMENT PARTS LIST

All parts listed may be ordered from your LOPI dealer. When ordering replacement parts, always give the following information:

1. Part Number
2. Part Description
3. Serial Number
4. Date of Purchase

PART NUMBER

PARTS DESCRIPTION

001	Auger Motor
002	Refractory Set
003	Draft Induction Motor
004	Convection Blower
005	Control Panel with Switches
006	Timing Block #646
007	Timing Block #46
008	Draft Flow Switch
009	170F N.C. Snap Disc
010	120F N.O. Snap Disc
011	Power Cord
012	Draft Flow Switch Tube
013	Firepot
014	Ashpan & Door Gasket Set
015	Door Glass Set

LIMITED WARRANTY

TRAVIS INDUSTRIES, INC. warrants the 400 - PS Pellet appliance to be defect-free in material and workmanship for five (5) years from the date of purchase, with the exception of the electrical components, blowers, gaskets, refractory and moving parts.. The exceptions listed are warranted for one (1) year from the date of purchase to be defect-free in material and workmanship.

Exclusions to this limited warranty include: Injury malfunction to the product, loss, damage, defect, failure to function due to accident, negligence, misuse, improper installation, alteration or adjustment of the manufacturers settings of components, lack of proper and regular maintenance, damage incurred while the unit is in transit, alteration, or act of God.

This limited warranty excludes damage caused by normal wear and tear, such as paint discoloration or chipping, worn or torn gasketing, eroded or cracked refractory, etc. Also excluded is damage to the unit caused by abuse, improper installation, the use of fuel or fuel loads other than specified by the manufacturer or use not set forth in the Owner's Manual. An overfired condition will cause warped metal parts and discolored or burned-off paint.

TRAVIS INDUSTRIES, INC. is free of liability for any damages caused by the unit, as well as inconvenience expenses, material and labor charges incurred by the removal or reinstallation of any 400 - PS unit. Incidental or consequential damages are not covered by this warranty. In some states, the exclusion of incidental or consequential damage may not apply.

This warranty does not cover any loss or damage incurred by the use or removal of any component or apparatus to or from the 400 - PS unit without the express written permission of TRAVIS INDUSTRIES, INC. and bearing a TRAVIS INDUSTRIES, INC. label of approval.

Any statement or representation of 400 - PS products and their performance contained in 400 - PS advertising, packaging literature, or printed material is not part of this limited warranty.

This warranty is automatically voided if the unit's serial number has been removed or altered in any way.

Only the original purchaser of a 400 - PS appliance is covered by this warranty. If the unit is used for commercial purposes, it is excluded from this warranty.

No dealer, distributor, or similar person has the authority to represent or warrant 400 - PS products beyond the terms contained within this warranty. TRAVIS INDUSTRIES, INC. assumes no liability for such warranties or representations.

THIS LIMITED WARRANTY IS THE ONLY WARRANTY SUPPLIED BY TRAVIS INDUSTRIES, INC., THE MANUFACTURER OF THE UNITS. ALL OTHER WARRANTIES, WHETHER EXPRESS OR IMPLIED, ARE HEREBY EXPRESSLY DISCLAIMED AND PURCHASER'S RECOURSE IS EXPRESSLY LIMITED TO THE WARRANTIES SET FORTH HEREIN.

This warranty is limited to the time frame set forth above. In some states, time limitations on warranties do not apply.

HOW TO USE YOUR 400 - PS FIVE-YEAR WARRANTY: If you find your unit to be defective in workmanship or material within a 5-year period from the date of purchase contact your local authorized LOPI dealer. If your dealer is unable to repair your unit's defect, he may process a warranty claim through TRAVIS INDUSTRIES, INC., including the name of the dealership where you purchased the unit, your receipt showing the date of the unit's purchase, and the serial number on your unit. At that time, you will be asked to ship your unit, freight charges prepaid, to TRAVIS INDUSTRIES, INC. TRAVIS INDUSTRIES, INC., at its option, will repair or replace, free of charge, your 400 - PS unit if it is found to be defective in material or workmanship within the time frame stated within this limited warranty. In addition, TRAVIS INDUSTRIES, INC. will refurbish your unit at no charge to you, restoring its appearance and condition. TRAVIS INDUSTRIES, INC. will ship your unit, freight charges prepaid by TRAVIS INDUSTRIES, INC., to your regional distributor, or dealership.

To register your TRAVIS INDUSTRIES, INC. Five-Year Warranty, complete the enclosed warranty card and mail it within ten (10) days of the unit purchase date to: TRAVIS INDUSTRIES, INC., 10850 117th Place N.E., Kirkland, Washington 98033.

OTHER RIGHTS:

This warranty provides you with certain legal rights. You may have additional rights, which vary from state to state, in regards to this warranty.

UNIT SERIAL NUMBER _____

DATE OF PURCHASE _____

DEALER NAME AND ADDRESS : _____

Complete and
save for your
records

Travis Industries, Inc. reserves the right to change, with out notice
product features or specifications described.



Travis Industries, Inc.

10850 117TH PLACE N.E. KIRKLAND, WA 98033