

Heritage

(DVL FS)

- Freestanding Direct Vent
 - Residential or Mobile Home
 - Natural Gas or Propane
- Contact local building or fire officials about restrictions and installation inspection requirements in your area.
- Save these instructions

WARNING: If the information in this manual is not followed exactly, a fire or explosion may result causing property damage, personal injury or loss of life.

- Do not store or use gasoline or other flammable vapors and liquids in the vicinity of this or any other appliance.
- **WHAT TO DO IF YOU SMELL GAS**
 - Do not try to light any appliance.
 - Do not touch any electrical switch; do not use any phone in your building.
 - Immediately call gas supplier from a neighbor's phone. Follow the gas supplier's instructions.
 - If you cannot reach your gas supplier, call the fire department.
- Installation and service must be performed by a qualified installer, service agency or the gas supplier.

- December, 1999 -

 **Travis Industries, Inc.**
10850 117th Place N.E. Kirkland, WA 98033

\$10.00

93508106

Tested and Listed by
Omni-Test Laboratories, Inc.
Beaverton, Oregon

Report # 028-S-19-1

ANSI Z21.88, CSA 2.33 MR8, CAN/CGA 2.17-M91



Safety Precautions

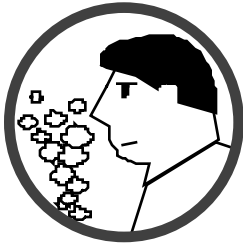

IF YOU SMELL GAS:

- * Do not light any appliance
- * Extinguish any open flame
- * Do not touch any electrical switch or plug or unplug anything
- * Open windows and vacate building
- * Call gas supplier from neighbor's house, if not reached, call fire department



- This unit must be installed by a qualified installer to prevent the possibility of an explosion. Your dealer will know the requirements in your area and can inform you of those people considered qualified. The room heater should be inspected before use and at least annually by a qualified service person. More frequent cleaning may be required due to excessive lint from carpeting, bedding material, etc.
- The instructions in this manual must be strictly adhered to. Do not use makeshift methods or compromise in the installation. Improper installation will void the warranty and safety listing.

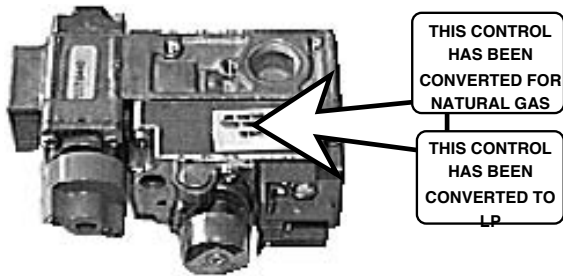

- This heater is either approved for natural gas (NG) or propane (LP). Burning the incorrect fuel will void the warranty and safety listing and may cause an extreme safety hazard. Check the label above the gas control valve to make sure it matches the fuel being used. Direct questions about the type of fuel used to your dealer.



- Contact your local building officials to obtain a permit and information on any installation restrictions or inspection requirements in your area. Notify your insurance company of this heater as well.



- If the flame becomes sooty, dark orange in color, or extremely tall, do not operate the heater. Call your dealer and arrange for proper servicing.

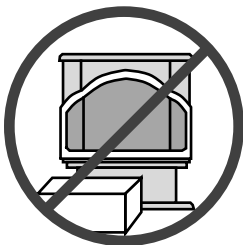

- It is imperative that control compartments, screens, or circulating air passageways of the heater be kept clean and free of obstructions. These areas provide the air necessary for safe operation.



- Do not operate the heater if it is not operating properly in any fashion or if you are uncertain. Call your dealer for a full explanation of your heater and what to expect.



- Do not store or use gasoline or other flammable liquids in the vicinity of this heater.
- Keep all furniture or other combustible items at least 36" away from the front of the heater.

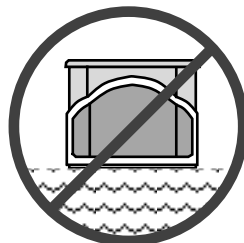

- Do not operate if any portion of the heater was submerged in water or if any corrosion occurs.



- Do not place clothing or other flammable items on or near the heater. Because this heater can be controlled by a thermostat there is a possibility of the heater turning on and igniting any items placed on or near it.

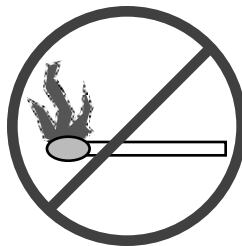

- Light the heater using the built-in piezo igniter. Do not use matches or any other external device to light your heater.



- The door (glass) should only be opened while lighting the pilot or conducting service. Damaged glass must be replaced.

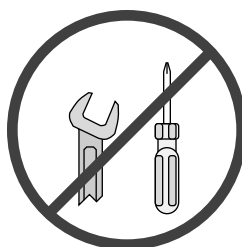

- Never remove, replace, modify or substitute any part of the heater unless instructions are given in this manual. All other work must be done by a trained technician. Don't modify or replace orifices.



- Any safety screen or guard removed for servicing must be replaced prior to operating the heater.
- Operate the heater according to the instructions included in this manual.
- If the main burners do not start correctly turn the gas off at the gas control valve and call your dealer for service.

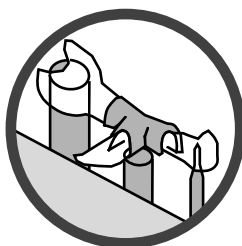

- Allow the heater to cool before carrying out any maintenance or cleaning.

- The pilot flame must contact the thermopile and thermocouple (see the illustration to the left). If it does not, turn the gas control valve to "OFF" and call your dealer.



- This unit is not for use with solid fuel
- Do not place anything inside the firebox (except the included fiber logs).
- If the fiber logs become damaged, replace with Travis Industries log set.



- Do not throw this manual away. This manual has important operating and maintenance instructions that you will need at a later time. Always follow the instructions in this manual.



- Do not touch the hot surfaces of the heater. Educate all children of the danger of a high-temperature heater. Young children should be supervised when they are in the same room as the heater.

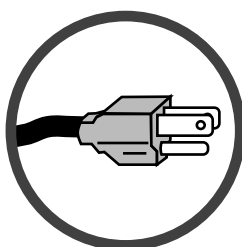

- Plug the heater into a 120V grounded electrical outlet. Do not remove the grounding plug.

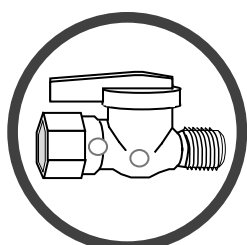

- Instruct everyone in the house how to shut gas off to the appliance and at the gas main shutoff valve. The gas main shutoff valve is usually next to the gas meter or propane tank and requires a wrench to shut off.



- Don't route the electrical cord in front of, over, or under the heater

- **Travis Industries, Inc. grants no warranty, implied or stated, for the installation or maintenance of your heater, and assumes no responsibility of any consequential damage(s).**

Introduction

Introduction.....	1
Important Information.....	1

Safety Precautions

Safety Precautions.....	2
-------------------------	---

Specifications

Installation Options.....	5
Features.....	5
Heating Specifications.....	5
Dimensions.....	5
Electrical Specifications.....	5
Fuel.....	5

Installation

Installation Warnings.....	6
Packing List.....	6
Installation Preparation.....	6
Stove Clearances.....	6
Mobile Home Requirements.....	6
Heater Placement Requirements.....	7
Floor Protection Requirements.....	7
Gas Line Installation.....	7
Gas Inlet Pressure.....	7
Vent Requirements.....	8
Altitude Considerations.....	8
Approved Vent Configurations.....	9
Restrictor Position.....	9
Elbows.....	9
Measuring Vent Lengths.....	9
Vertical Term's with (or without) 2 45° Elbows.....	10
Horizontal Terminations.....	11
Vertical Term's with Two 90° Elbows.....	12
Termination Requirements.....	13
Finalizing the Installation.....	14
Opening the Door.....	16
Log Set and Coal Installation.....	17

Operation

Safety Notice.....	18
Location of Controls.....	18
Starting the Pilot Flame.....	19
Starting the Heater for the First Time.....	20
Turning the Heater On and Off.....	20
Adjusting the Flame Height.....	20
Adjusting the Blower Speed.....	21
Normal Operating Sounds.....	21

Maintenance

Cleaning Your Heater.....	22
Yearly Service Procedure.....	22
Troubleshooting Steps.....	23
How this Heater Works.....	24
Wiring Diagram.....	25
Replacement Parts.....	25

Safety Label

Safety Label.....	26
-------------------	----

Warranty

Warranty.....	27
---------------	----

Optional Equipment & Addenda

LP Conversion Instructions.....	28
Thermostat.....	31
Remote Thermostat.....	32
Gold Grill.....	32
Gold Door.....	33
Fireback.....	33

Installation Addenda

Class A Chimney Conversion Kit.....	34
Interior Masonry Chimney Conversions.....	35

Index

Index.....	36
------------	----

Installation Options:

- Freestanding Stove
- Residential or Mobile Home
- Horizontal or Vertical Vent

Features:

- Works During Power Outages
- Realistic “Wood Fire” Look
- Optional Thermostat or Remote Control
- Variable-Rate Heat Output
- Blower Standard

Heating Specifications:

Approximate Heating Capacity (in square feet)*.....1,200 to 2,000 With Blower, 800 to 1,600 Without
Input from Low to High (in BTU’s per hour).....23,000 to 43,000

Steady State Efficiency.....up to 78% (NG), 81% (LP)

AFUE.....71% (NG), 73.7% (LP)

- Heating capacity will vary depending on the home’s floor plan, degree of insulation, and the outside temperature.

** Efficiency rating is a product of thermal efficiency rating determined under continuous operation independent of installed system. To measure the net BTU’s, multiply the BTU input by the efficiency percentage.

Dimensions:

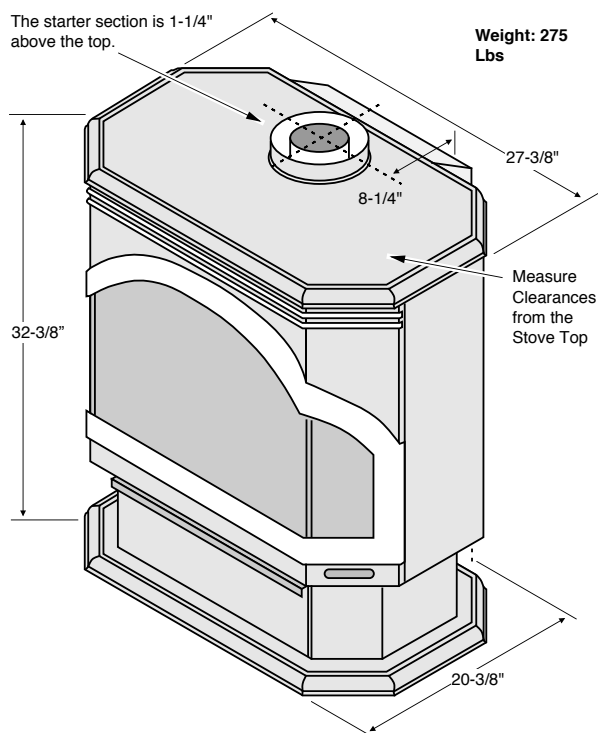

Electrical Specifications

Electrical Rating.....115 Volts, 0.8 Amps, 60 Hz (92 watts on high)

Fuel:

This heater is shipped in natural gas (NG) configuration but may be converted to propane (LP) using the included LP conversion kit. The sticker on top of the gas control valve will verify the correct fuel.

Installation Warnings

- ! Failure to follow all of the requirements may result in property damage, bodily injury, or even death.
- ! This heater must be installed by a qualified installer who has gone through a training program for the installation of direct vent gas appliances.
- ! This appliance must be installed in accordance with all local codes, if any; if not, follow current ANSI Z223.1 or NFPA 54 in the USA or the current CGA B149 in Canada.
- ! In Manufactured or Mobile Homes this appliance must be installed to the applicable Mobile Home Standards: CAN/CSA Z240 MH, the Manufactured Home Construction and Safety Standard, Title 24 CFR, Criteria for Manufactured Home Installations, Sites and Communities, and/or ANSI/NFPA 501A. This appliance may be installed in Manufactured Housing only after the home is site located.
- ! This appliance is designed for natural gas or propane (LP). Check the sticker on top of the gas control valve.
- ! All exhaust gases must be vented outside the structure of the living-area. Combustion air is drawn from outside the living-area structure.
- ! Notify your insurance company before hooking up this appliance.
- ! The requirements below are divided into sections - all requirements must be met simultaneously.

Packing List

- DVL Stove
- Owner's Manual
- Log Set with Coals & Embers
- Propane Conversion Kit

Installation Preparation

- HINT: If converting to LP, convert the appliance prior to installation.
- HINT: Install the logs last - they are fragile.
- HINT: When determining the location of the stove, locate the wall studs (for horizontal penetrations) and ceiling trusses (for vertical penetrations). You may wish to adjust the stove position slightly to ensure the vent does not intersect with a framing member.
- HINT: Fumes and smoke from the paint curing and oil burning off the steel may occur the first time you start this heater. This is normal. We recommend you open windows to vent the room.

Stove Clearances

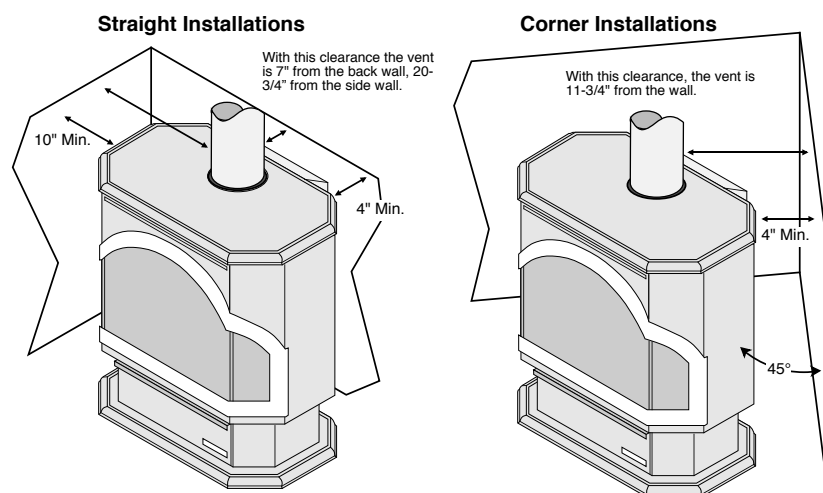

Mobile Home Requirements

- When the stove is installed in a mobile home, it must be bolted to the floor and the appliance grounded (use the blower with a grounded circuit or other suitable grounding method - current ANSI/NFPA 70 or CSA C22.1).

Heater Placement Requirements

- Heater must be installed on a level surface capable of supporting the heater and vent
- Due to the high temperature of the heater, it should be located out of traffic and away from furniture and draperies. Heater must be placed so no combustibles are within, or can swing within 36" of the front of the heater (e.g. drapes, doors)
- ? When placed in a location where the floor to ceiling height is under 7 feet, the installation is considered an alcove and must meet the following requirements:
 - The alcove floor to ceiling height must be at least 60" tall
 - The alcove must not be more than 48" deep before the ceiling returns to 7'
 - The alcove must be at least 47-3/8" wide
- The heater must not be placed so the vents below or above the door, along the sides of heater, or along the back of the heater can become blocked.

Floor Protection Requirements

- When the stove is installed directly on carpeting, vinyl or other combustible material other than wood flooring or a high pressure laminate wood floor, the stove must be installed on a metal or wood protection panel extending the full width and depth of the heater (Minimum 27-3/8" wide by 20-3/8" deep).

Gas Line Installation

- ! The gas line must be installed in accordance with all local codes, if any; if not, follow current ANSI Z223.1 or NFPA 54 in the USA and the current CGA B149 in Canada.
- ! The heater and gas control valve must be disconnected from the gas supply piping during any pressure testing of that system at test pressures in excess of 1/2 psig (3.45 kPa). For pressures under 1/2 psig (3.45 kPa), isolate the gas supply piping by closing the manual shutoff valve.
- This heater is designed for natural gas but can be converted to propane. Check the sticker on the top of the gas control valve to make sure the correct fuel is used.
- Leak test all gas line joints and the gas control valve prior to and after starting the heater.
- The gas inlet accepts a 3/8" F.P.T. Fitting
- The location of the gas inlet is shown below
- A manual shutoff valve is required for installation (it must be located within 3' of the heater)

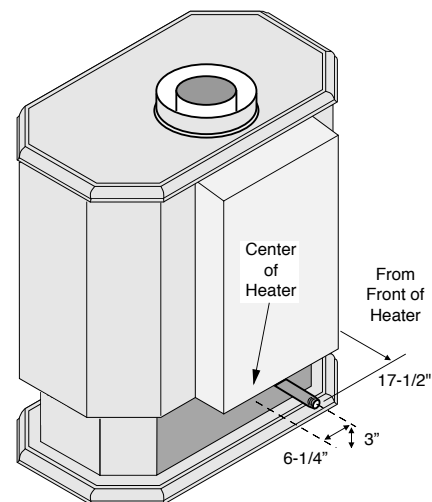

Gas Inlet Pressure

- With the heater off, the inlet pressure must meet the requirements listed in the table below
- ? If the pressure is not sufficient, make sure the piping used is large enough and the total gas load for the residence does not exceed the amount supplied.
- ? The supply regulator (the regulator that attaches directly to the residence inlet or to the propane tank) should supply gas at the suggested input pressure listed below. Contact the local gas supplier if the regulator is at an improper pressure.

	Standard Input Pressure
Natural Gas	7" W.C. (1.74 Kpa)
Propane	11" W.C. (2.73 Kpa)

Approved Vent Configurations

Restrictor Position

- A vent restrictor is built into the appliance to control the flow rate of exhaust gases. This ensures proper flames for the wide variety of vent configurations. The restrictor consists of a butterfly valve in the air inlet and an adjustment plate with index holes used to hold the valve in a fixed position. Depending upon the vent configuration, you may be required to adjust the restrictor position. The charts for approved vent configurations describe which position the vent restrictor must be in.

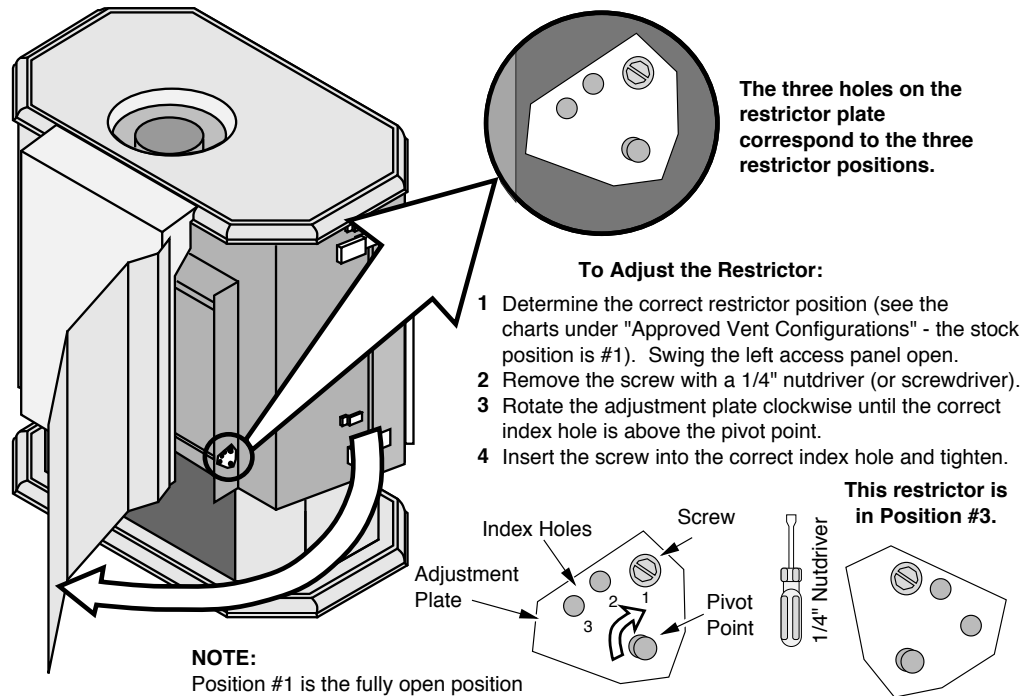

Elbows

- 2 Elbow maximum (two 45° or two 90°, not one 45° and one 90°)

Elbows add 3" to the length of the vent system.

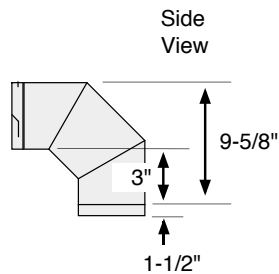

Measuring Vent Lengths

Vent sections overlap each other by 1-1/2"

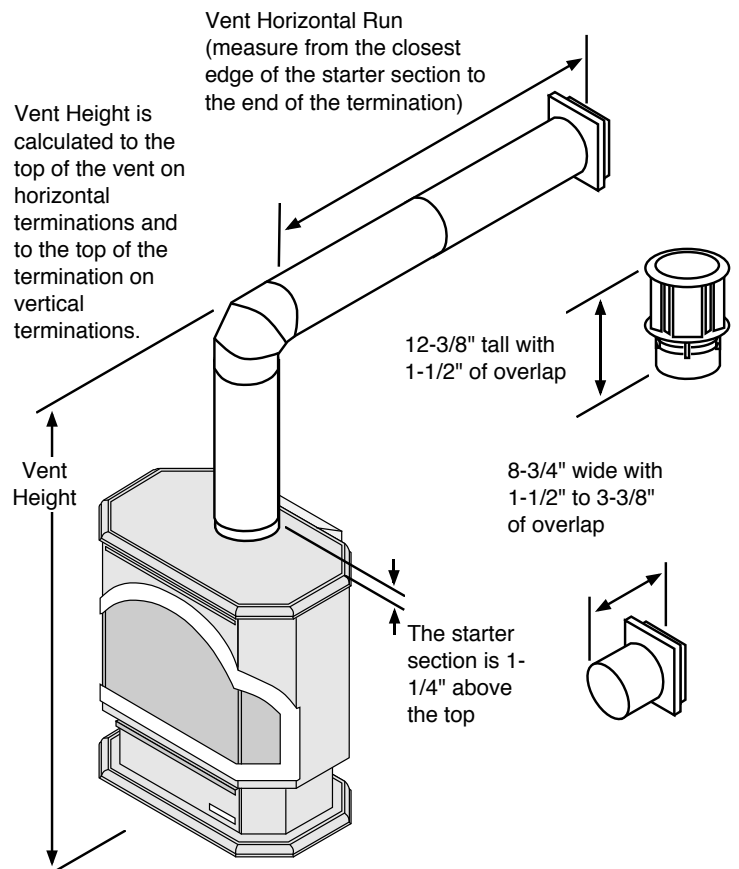
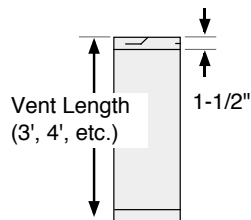

Approved Venting Configurations for Vertical Terminations with (or without) Two 45° Elbows

- 10' Minimum System Height (with or without offsets)
- 35' Maximum System Height
- 6' Maximum Offset
- The termination must fall within the shaded area shown in the chart. Use the indicated restrictor position.
- If using offsets, use the table below to calculate the vertical rise and horizontal offset

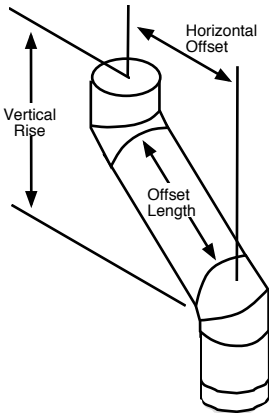

Offset Length	Hor. Offset	Vert. Rise
None	5"	1'
1' Section	1'	1' 7"
2' Section	1' 9"	2' 4"
3' Section	2' 5"	3'
4' Section	3' 2"	3' 8"
4' + 1' Section	3' 9"	4' 4"
4' + 2' Section	4' 6"	5'
4' + 3' Section	5' 2"	5' 9"
4' + 4' Section	6'	6' 9"

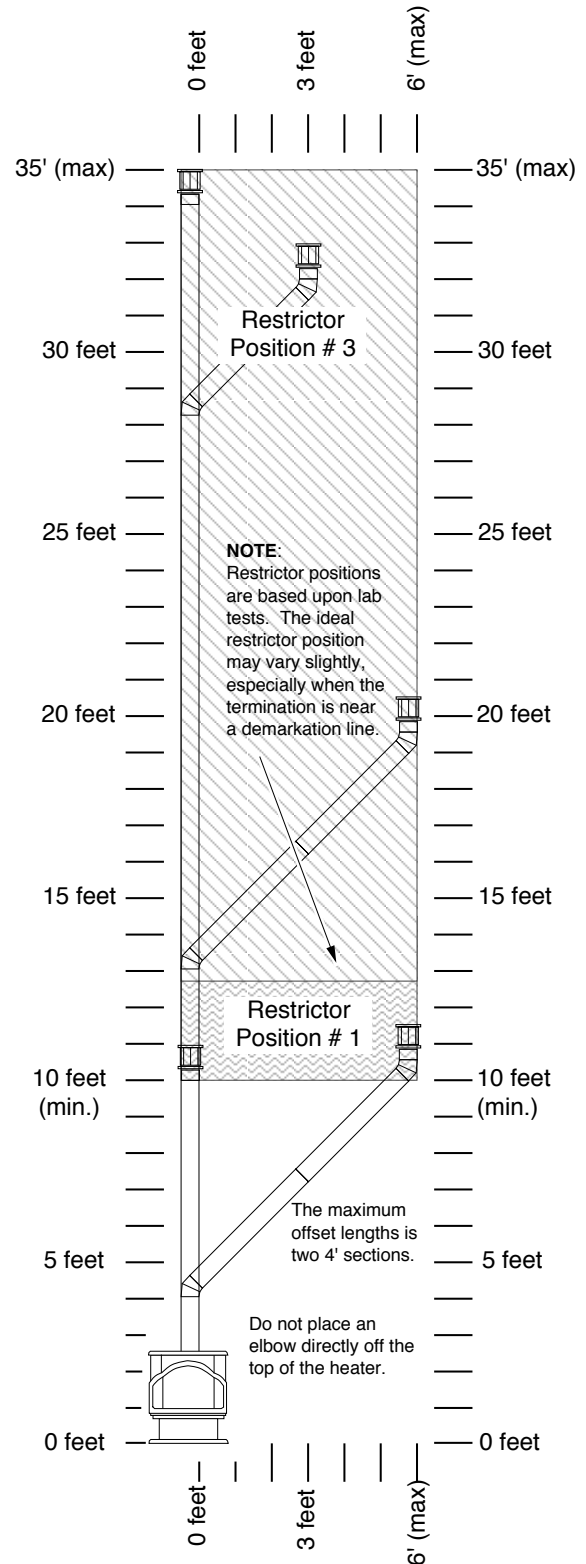

Approved Venting Configurations with a Horizontal Termination

- If using a Snorkel Termination (14" or 36") add the snorkel height to the vertical height (snorkel terminations are used primarily for basement installations).
- The termination must fall within the shaded area shown in the chart. Use restrictor position #1.

Natural Gas (NG) Installations

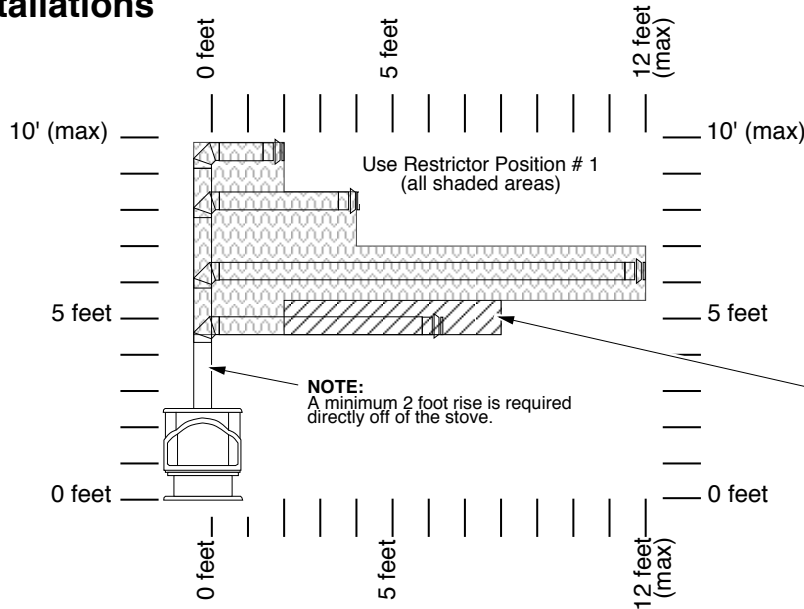

NOTE:
Horizontal sections require a 1/4" rise every 12" of travel.

NOTE:
If terminating into this area when installed at an altitude above 2,000 feet, the main burner orifice will need to be de-rated as follows:

2,000' to 8,000'	NG #31
8,000' or higher	#32

Propane (LP) Installations

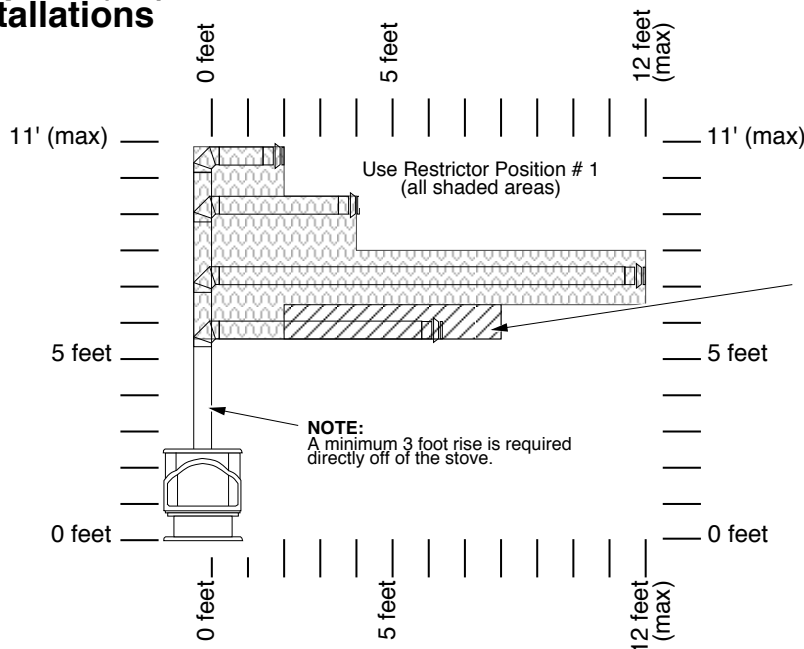

NOTE:
Horizontal sections require a 1/4" rise every 12" of travel.

NOTE:
If terminating into this area when installed at an altitude above 2,000 feet, the main burner orifice will need to be de-rated as follows:

2,000' to 4,000'	LP #49
4,000' to 8,000'	#50
8,000' or higher	#51

Approved Venting Configurations for Vertical Terminations with Two 90° Elbows

- The termination must fall within the shaded area shown in the chart. Use the indicated restrictor position.

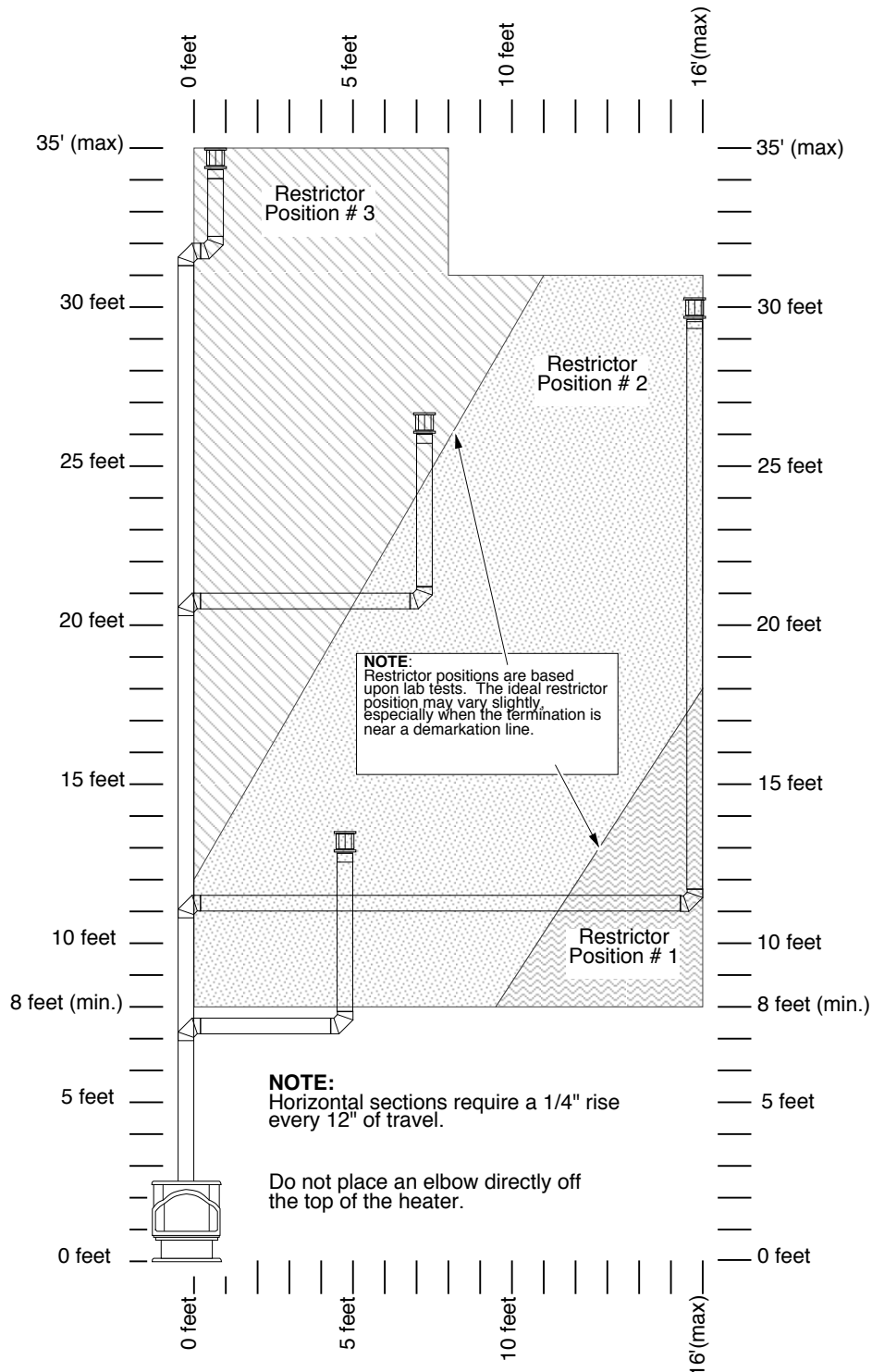

Termination Requirements (see the illustration below)

- A Minimum 9" clearance from any door or window
 - B Minimum 12" above any grade, veranda, porch, deck or balcony
 - C Minimum 12" from outside corner walls
 - D Minimum 12" from inside corner walls
 - E Minimum 11" clearance below unventilated soffits or roof surfaces
Minimum 18" clearance below ventilated soffits
Minimum 6" clearance from roof eaves
NOTE: Vinyl surfaces require 24"
 - F Minimum 18" clearance below a veranda, porch, deck or balcony (must have two open sides)
 - G Minimum 48" clearance from any adjacent building
 - H Minimum 84" clearance above any grade when adjacent to public walkways or driveways
NOTE: may not be used over a walkway or driveway shared by an adjacent building
 - I Minimum 48" clearance from any mechanical air supply inlet, 72" for Canada
 - J Minimum 36" clearance above and 48" below and to the sides of non-mechanical air supply inlet
 - K Minimum 36" from the area above the meter/regulator (vent outlet)
 - L Minimum 36" from the meter/regulator (vent outlet)
 - M Minimum 12" above the roof line (for vertical terminations)
- *Note: In Canada the vent termination must be a minimum 2' tall and 2' above any portion of the roof within 10' of the vent.**
- N Minimum 24" horizontal clearance to any surface (such as an exterior wall) – for vertical terminations

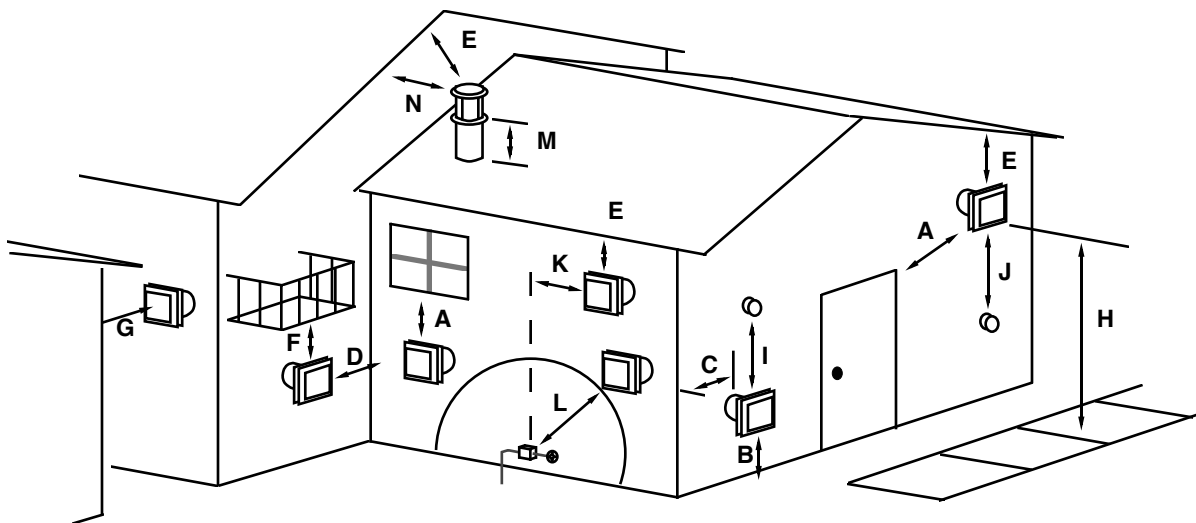
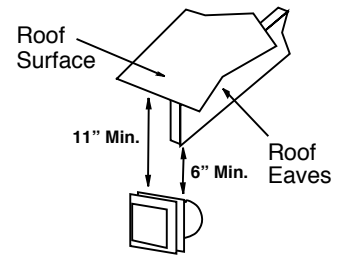

NOTE: Measure clearances to the nearest edge of the exhaust hood.

- Use the vinyl siding standoff (#950) when installing on an exterior with vinyl siding.
- Vent termination must not be located where it will become plugged by snow or other material
- These clearances meet UMC-1994 and the CNA/CGA-B149 code standards.

Finalizing the Installation

- ! Turn the gas control valve to "OFF" prior to conducting any service.
- 1 Open the door (see page 16).
- 2 Install the log set and coals (see page 17).
- ! We recommend you purge the gas line at this time (with the door open). This allows gas to be detected once it enters the firebox, ensuring gas does not build up.
- 3 Close and secure the door (see page 16).
- 4 Turn on gas to the heater. Leak test all gas joints prior to starting the appliance. Start the pilot. Start the main burner. Leak test all gas joints again.
- 5 Check the pilot flame to make sure it looks like the illustration below. Adjust the pilot flame if necessary.

The pilot flame should touch only the top 3/8" of the thermopile. Adjust the pilot up or down as necessary.

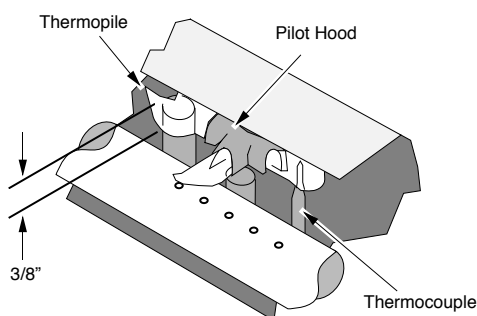

To adjust the pilot flame, remove the cover screw and gasket and turn the needle valve (NOTE: if the needle valve is totally unscrewed, gas will come out of this port). Clockwise lowers the flame while counter-clockwise raises it. Replace the cover screw and gasket

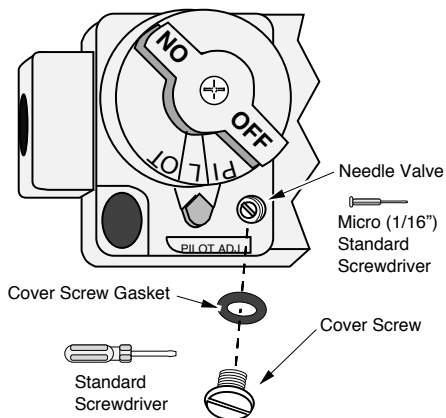

6 Let the heater burn for fifteen minutes. Adjust the air shutter, if necessary, to achieve the correct looking flame (see the illustration below).

- The air shutter adjusts the amount of air that mixes with the gas before it exits the burner holes. It is used to fine-tune the flame for differences in altitude and vent configuration.

! If the air shutter is in its fully open position, yet the flames remain sooty, shut off gas to the heater and contact your dealer for a remedy.

(a) Loosen this screw two turns.

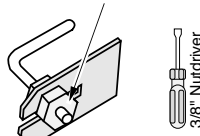

(b) Slide the air shutter rod in or out.

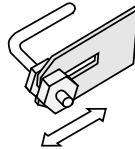

IN = MORE AIR
OUT = LESS AIR

(c) Tighten the nut to secure the shutter.

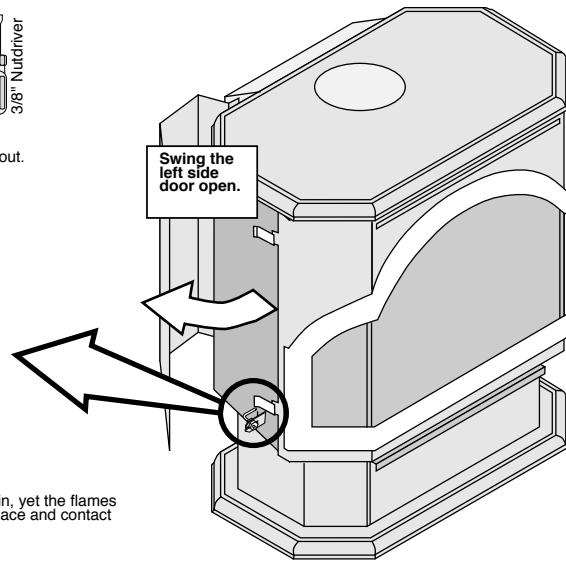

NOTE: If the air control is all the way in, yet the flames remain sooty, shut off gas to the fireplace and contact a qualified gas service technician.

NOTE: The logs must be installed correctly to monitor the flame while adjusting the air shutter.

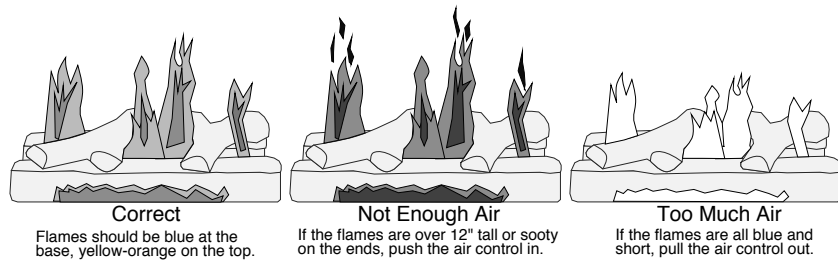

! If the vent configuration is installed incorrectly the vent may cause the flames inside the heater to lift or “ghost” – a dangerous situation. Inspect the flames after installation to insure proper performance. If the vent configuration is correct, yet the flames are lifting or ghosting, shut off gas to the heater and contact the dealer for information on remedying the problem.

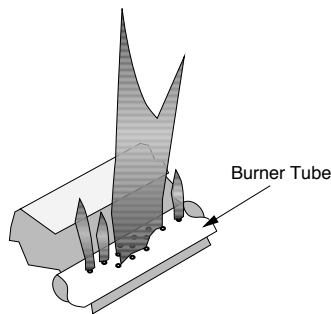

The flames should burn right off the top of the burner ports (if they are too blue, adjust the air control).

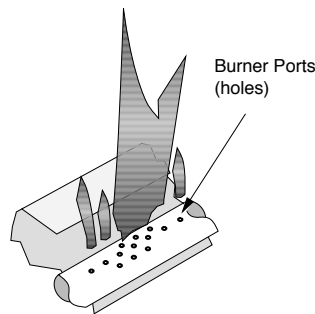

If the flames are lifting, yet the vent configuration is correct, contact your dealer.

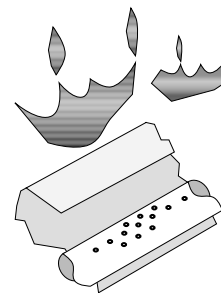

If the flames are ghosting, yet the vent configuration is correct, contact your dealer.

7 Turn the flame adjust knob to its highest position - the flames should be a maximum 10” to 12” tall. Check the flame on low position. The flames should burn off of each burner hole. If the heater does not work correctly, contact your dealer for a remedy.

8 Give this manual to the home owner and fully explain the operation of this heater.

Opening the Door

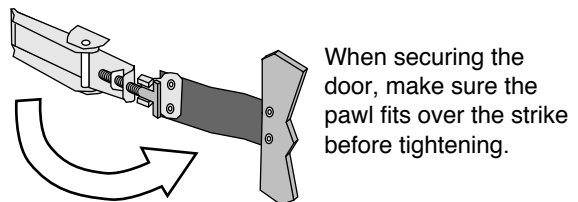
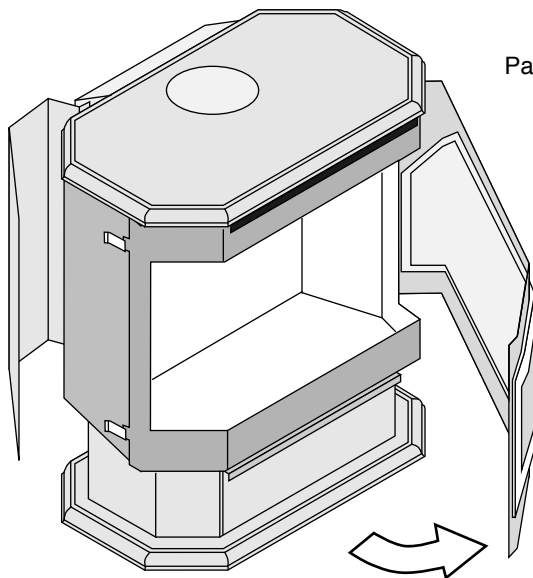
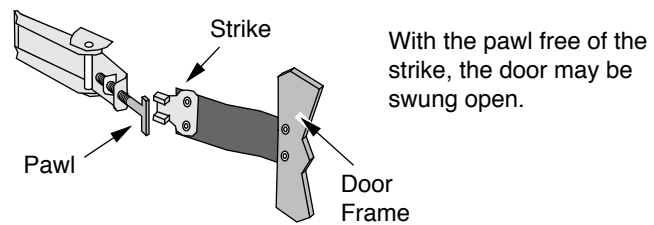
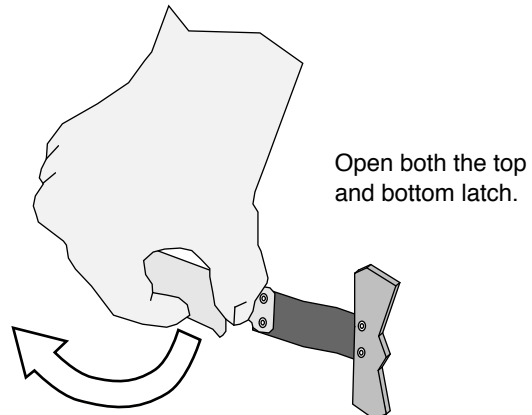
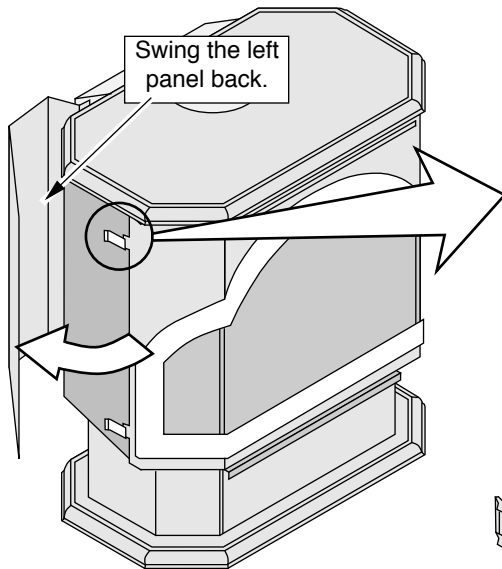

NOTE: Do not overtighten the pawl by screwing it in. This will permanently damage the latch.

Log Set and Coal Installation

Preparing the Glowing Embers:

The glowing embers comes in a single strip. Stretch them as thin as possible (nearly transparent) to form three strips of the following sizes:

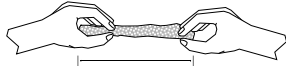

One Strip Approximately
7-1/2" by 1-1/2"



Two Strips Approximately
3" by 1-1/2"

There may be extra material - save it for future use.

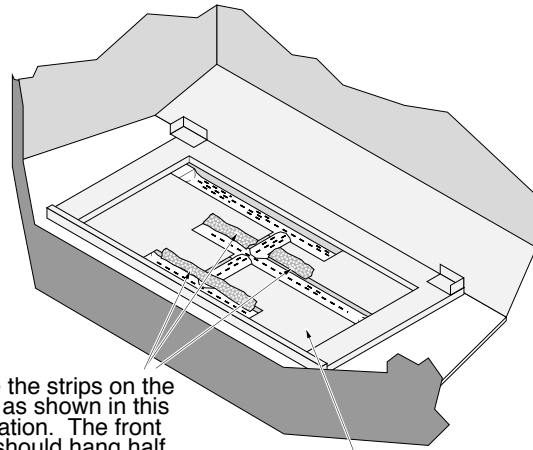

Place the strips on the grate as shown in this illustration. The front strip should hang half way over the burner.

Grate

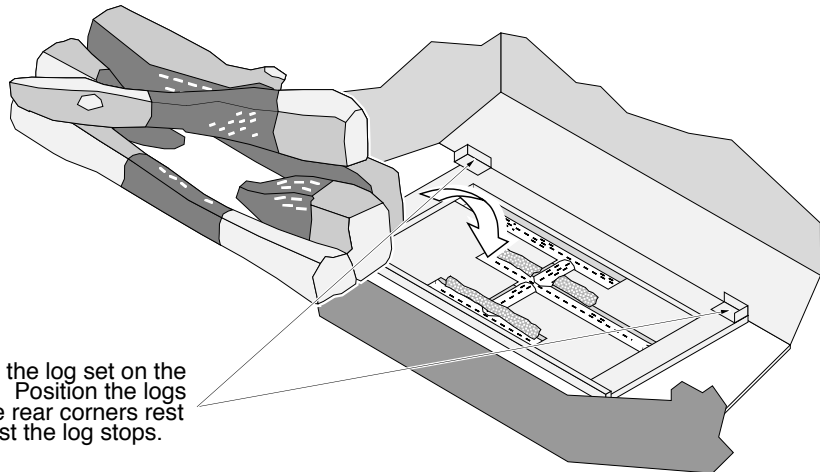

Place the log set on the grate. Position the logs so the rear corners rest against the log stops.

Tuck the front of the ember strip down, behind the burner with a screwdriver. Make sure the mat of ember wool is not over the burner holes. Tuck it behind the burner tube if necessary.

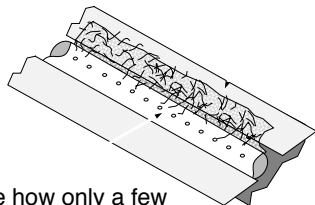

Note how only a few "whiskers" are over the burner holes.

Side View

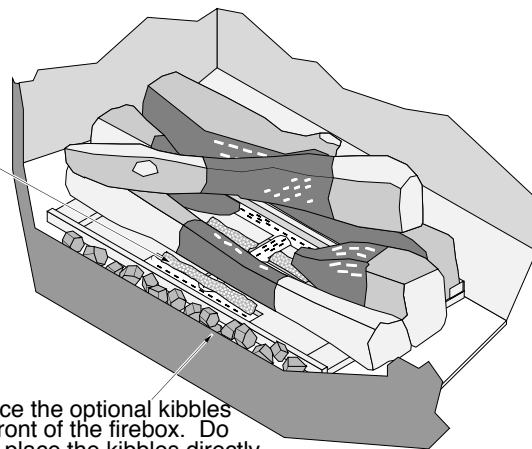

Place the optional kibbles in front of the firebox. Do not place the kibbles directly over the burner holes.

Safety Notice

Read this entire manual (especially the “Safety Precautions” on pages 2 and 3) before using this stove. Failure to follow the instructions may result in property damage, bodily injury, or even death.

Location of Controls

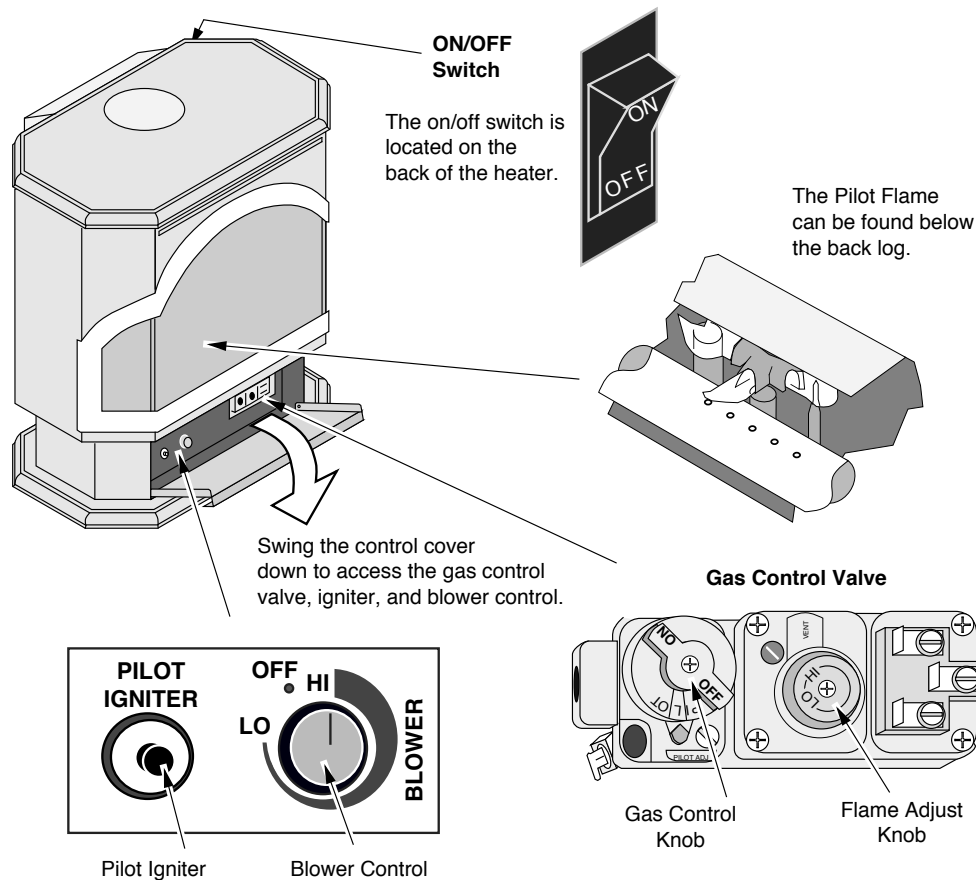

On/Off Switch

This control is used to turn the main burner on and off.

Gas Control Knob

This knob is used to control gas to the heater and for starting the pilot. There are three positions, ON, OFF, & PILOT. The pointer directly below the knob indicates the position this knob is in.

Flame Adjust Knob

This knob controls the flame height from low (“LO”) to high (“HI”). The pointer to the upper left of the knob points to the position this knob is in.

Pilot Igniter

The pilot igniter is used only to start the pilot. When pressed, it sends an electrical charge to the pilot assembly. This creates a blue spark directly next to the pilot, igniting the pilot flame.

Blower Control

This knob controls the speed of the internal convection blower that pushes the heated air into the room.

- ? If using a remote control or thermostat, the On/Off Switch must be left “ON”. Turning the On/Off Switch “OFF” will keep the heater off always.

Starting The Pilot Flame

The pilot flame is required to ignite the main burners (it also plays a safety role). It should be left on once lit. It will stay lit unless the gas control valve is turned to "OFF". However, the pilot will go out if the gas is shut off, the propane tank runs out (or low) or if the stove malfunctions. If the pilot turns off frequently, call your dealer for information. To start the pilot follow the directions below:

WARNING:

When lighting or re-lighting the pilot, the door must be opened (see page 16).

- a Open the door (see page 16 for details).
- b Push the gas control knob in slightly and turn it to the "OFF" position. The knob will not turn from "ON" to "OFF" unless the knob is depressed slightly. Wait five minutes to let any gas that may have accumulated inside the firebox escape. If you smell leaking gas, follow the directions on the cover "IF YOU SMELL GAS".
- c Turn the gas control knob to the "PILOT" position and press the knob in, this will allow gas to flow to the pilot light. Press the red button on the pilot igniter repeatedly until you see the pilot light.

WARNING:

If the pilot does not light after 15 seconds, release the knob and call your dealer for service. Do not attempt to light pilot until service has been performed.

NOTE:

You may wish to remove the log set to gain a better view of the pilot (see page 17).

- d Keep the gas control knob depressed for 30 seconds once it is lit.
- e Release the gas control knob. If the pilot goes out, repeat step C. If the pilot refuses to stay lit, call your dealer for service. With the pilot lit, proceed to step "f".
- f Close and latch the door.
- g Turn the gas control knob counter-clockwise to "ON". The pilot is now lit and the heater can be turned on and off.

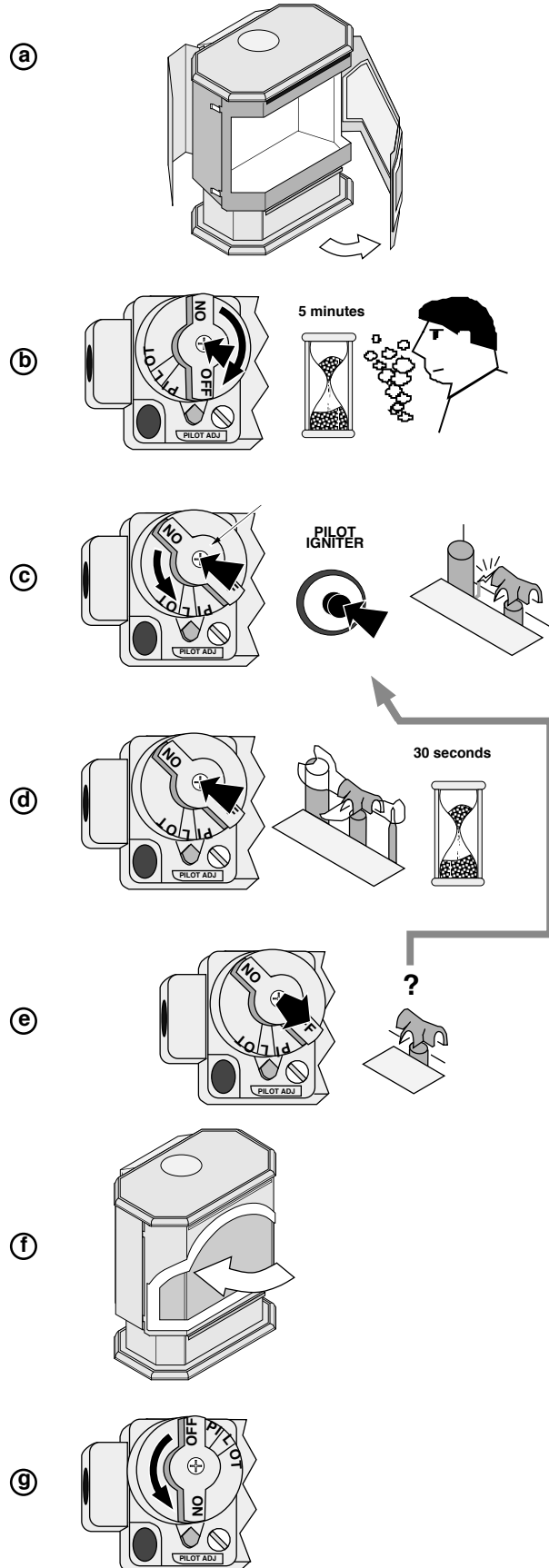

Starting the Heater for the First Time

Cleaning Gold Surfaces

Fingerprints or other marks left on gold surfaces may become etched in place if they are not wiped clean prior to turning the stove on. With the heater cool, clean gold surfaces with denatured alcohol and a soft cloth.

Fumes from the Painted Surfaces Curing

Burn the heater at a medium setting for approximately one hour the first time. This will cure the painted surfaces. **Fumes** from the paint curing and oil burning off the steel may occur. This is normal. We recommend you open the window to vent the room.

Condensation

Water may appear on the glass each time you start the heater - this is normal.

Blue Flames

The flames will be blue when first started. After fifteen minutes the flames will turn a more realistic yellow and orange color.

Turning the Heater On and Off

After the pilot has been started...

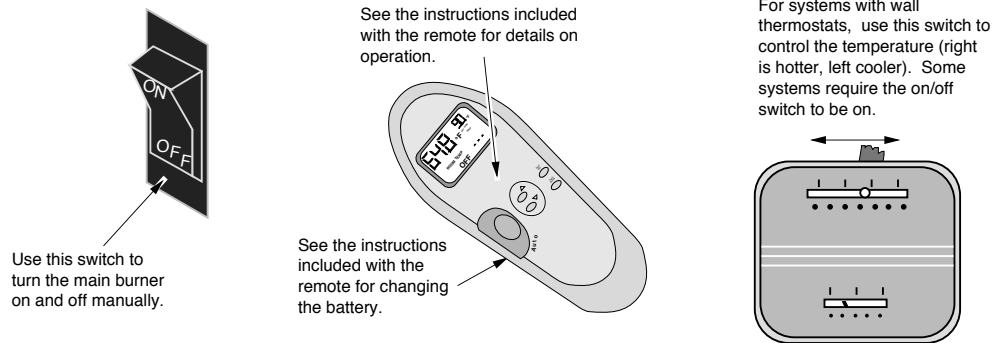

Warning: Do not place combustible items on top or directly in front of the heater, even temporarily. The optional thermostat may start the heater causing a combustible item to ignite.

Note: If the heater turns on and off frequently while using the thermostat, you may want to adjust the flame height down until it produces just enough heat needed.

Adjusting the Flame Height

Your heater has an adjustable flame to tailor the look and heat output to your specific needs. It is adjusted by turning the middle dial on the gas control valve.

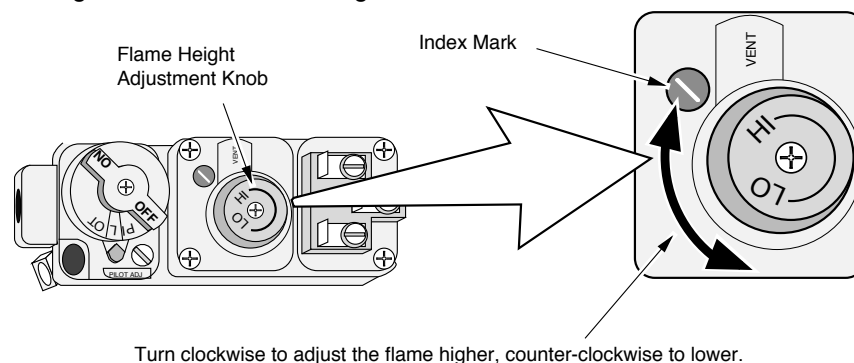

Adjusting the Blower Speed

The blower helps transfer heat from the heater into the room. It will not turn on until the heater is up to temperature (approximately 10 minutes after starting). See the illustration below for instructions on adjusting the blower speed.

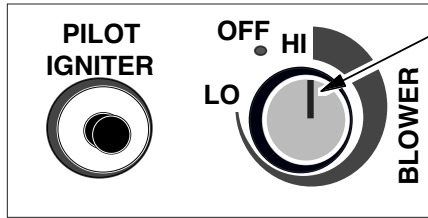

Blower Knob

Turn the knob all the way counter-clockwise to turn the blower off. One click clockwise turns the blower to high speed. Turning the knob clockwise from the high position decreases the speed of the blower.

Normal Operating Sounds

Pilot Flame
The pilot flame, which remains on, makes a very slight "whisper" sound.

Gas Control Valve
As the gas control valve is turned on and off you will hear a dull clicking sound. This is the valve opening up and shutting down.

Blower
The optional blower pushes heated air into the room. The sound will increase as the speed is increased.

The appliance may creak with change of temperature.

Blower Snap Disk
This part can produce a clicking sound as it turns the blower on and off.

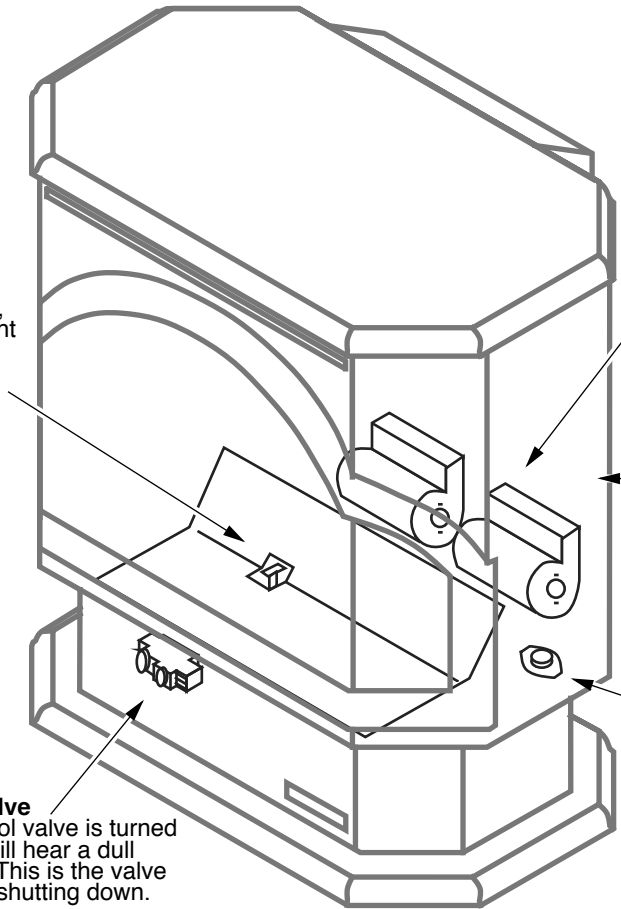

Cleaning Your Heater

Warning Fingerprints or other marks left on the optional gold surface may become etched in place if they are not wiped clean prior to turning the stove on.

With the heater cool, use denatured alcohol and a soft cloth to clean gold surfaces. Other cleaners may leave a film that may become etched into the gold.

Yearly Service Procedure

Warning Failure to inspect and maintain the heater may lead to improper combustion and a potentially dangerous situation. We recommend the following procedures be done by a qualified technician.

- 1 Check the pilot flame. It should engulf approximately 3/8" of the top of the thermocouple (see illustration below). If it does not, contact your dealer for service.
- 2 Shut off gas to the heater by turning the gas control knob to "OFF" (see step A under "Starting the Pilot" on page 19). Let the heater cool for 15 minutes. Open the door (see page 16).
- 3 Remove the log set and embers (see page 17 - **NOTE: the log set is fragile**). If any log is cracked or deteriorated, replace it when re-installing. Check the logs for sooting. If excessive sooting is found, the heater will require adjustment. Contact your dealer.
- 4 Clean the burner pan (especially in the burner holes and slots) and inspect the following:
 - Check for burner pan holes that are cracked, severely warped, or corroded.
 - Check the firebox and area around the pilot to make sure there is no warping or damage.

If any problem is found, discontinue use and contact your dealer for service.

Before Disassembly: Check the pilot flame. It should touch the top 3/8" of the thermopile and thermocouple.

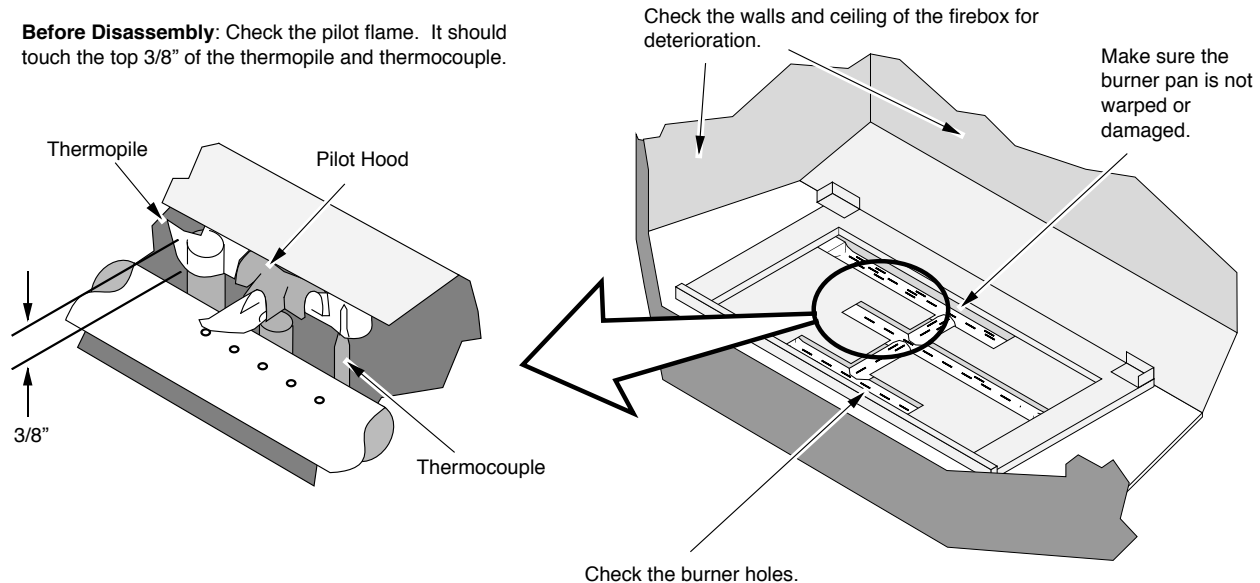

- 5 Replace the log set. Inspect the glass gasket. If it is deteriorated, replace. If the glass is damaged, replace it.
- 6 Check the gas control valve and all of the gas lines. If any damage is found, discontinue use and contact your dealer for service.
- 7 To check the door seal, place a dollar bill along the door perimeter then close and latch the door. If the dollar bill is held in place securely, the door seal is adequate. However, if the dollar bill slides out easily, you should adjust the door. Contact your dealer to obtain directions on tightening the door seal.

- 8 Start the pilot and turn on the main burner. The flames should be orange/yellow and not touch the top of the firebox. If the pilot or main burners do not burn correctly, contact your dealer for service. Monitor the blower operation.
- 9 Remove any debris or vegetation near the vent termination. Contact your dealer if any sooting or deterioration is found near the vent termination.

Troubleshooting Steps

Problem:	Possible Cause:	Remedy:
Pilot Will Not Flame	A gas shut off valve is turned off The gas control knob isn't turned to "PILOT" The valve control knob isn't pushed in The igniter wasn't pressed repeatedly No spark from igniter.....	Check all gas shut off valves See "Starting the Pilot Flame" Pg 19 See "Starting the Pilot Flame" Pg 19 See "Starting the Pilot Flame" Pg 19 Igniter Faulty - Contact your Dealer
Main Burners Will Not Start	The pilot flame has gone out..... The gas control valve is turned to "PILOT" or "OFF" The ON/OFF switch is turned to "OFF" The remote control is not working correctly..... The thermostat is disconnected or set too high ...	See "Starting the Pilot Flame" Pg 19 See "Starting the Pilot Flame" Pg 19 Turn the ON/OFF switch to "ON" Replace the batteries Set the thermostat to a lower temperature
Remote Control Does Not Work	The pilot light has gone out..... The gas control valve is turned to "PILOT" or "OFF" The ON/OFF switch is turned to "OFF" The remote is too far away from the heater The remote control receiver is turned "OFF"..... One of the two remote control batteries is dead...	See "Starting the Pilot Flame" Pg 19 See "Starting the Pilot Flame" Pg 19 Turn the ON/OFF switch to "ON" Use the remote closer to the heater See the remote control instructions See the remote control instructions
Thermostat Does Not Work	The pilot flame has gone out..... The gas control valve is turned to "PILOT" or "OFF" The ON/OFF switch is turned to "OFF" The thermostat is set too high.....	See "Starting the Pilot Flame" Pg 19 See "Starting the Pilot Flame" Pg 19 Turn the ON/OFF switch to "ON" Set the thermostat to a lower temperature
Blower Does Not Operate	Make sure blower control is turned "ON" The heater is not getting electricity The heater is not up to temperature.....	See "Adjusting Blower Speed" Pg. 21 Make sure it is plugged in and the outlet is providing electricity See "Operating Your Heater"
Flames Are Too Blue	The heater has just been started.....	This is normal - see "Starting the Heater for the First Time"
Flames Are Too Short (Under 6")	The flame height may be turned too low.....	Turn the flame height to "HI" - See "Adjusting the Flame Height"

How this Heater Works

Warning This heater was designed with safety as the primary concern. Many of the components inside this heater are for safety purposes. Therefore, only certified gas service technicians should service this heater.

What Turns the Main Burners On and Off

This heater uses a millivolt system to control its operation (a millivolt is a very small amount of electricity). The thermopile and thermocouple generate electricity when heated by the pilot flame. This electricity is used to operate the gas valve. Without enough electricity, the gas valve will not turn on. That is why when starting the pilot the gas control knob has to be pressed in long enough for the thermocouple to heat up and generate enough electricity. The thermopile provides power for the ON/OFF switch, remote control, or thermostat (see the illustration below). Because the thermopile generates the electricity needed to turn the heater on and off, this heater can be operated when the power is out (although the blower will not run).

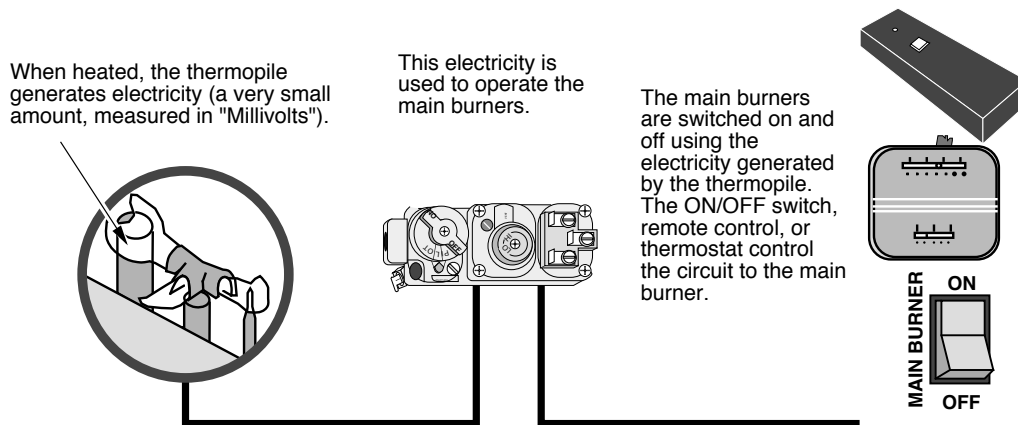

What Prevents Gas Buildup

- This appliance utilizes a high-technology gas valve in conjunction with a pilot flame to ensure no gas builds up inside the firebox.
- The thermocouple (next to the pilot) senses when the pilot flame is lit. If the pilot flame goes out, this thermocouple no longer generates electricity, causing the gas valve to automatically shut off all gas to the heater, preventing the pilot or burner from spilling gas into the firebox.

Pilot Flame

The pilot flame is a time-proven component that eliminates the possibility of gas buildup inside the firebox.

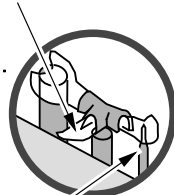

Thermocouple

The thermocouple generates a small amount of electricity. If the pilot flame goes out, the gas valve automatically shuts off all gas.

Gas Valve

This high-technology valve automatically shuts off all gas if it does not receive a signal from the thermocouple. If any component is damaged or sensing a malfunction, or if the wiring is damaged, it will shut off all gas.

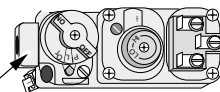

External Shut Off Valve

This valve is placed on the gas line to shut off gas to the appliance during maintenance procedures.

Ceramic Glass

The glass in your heater is the most durable glass available. It has been tested to be extremely resistant to breakage from temperature changes.

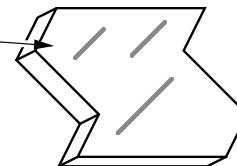

Wiring Diagram

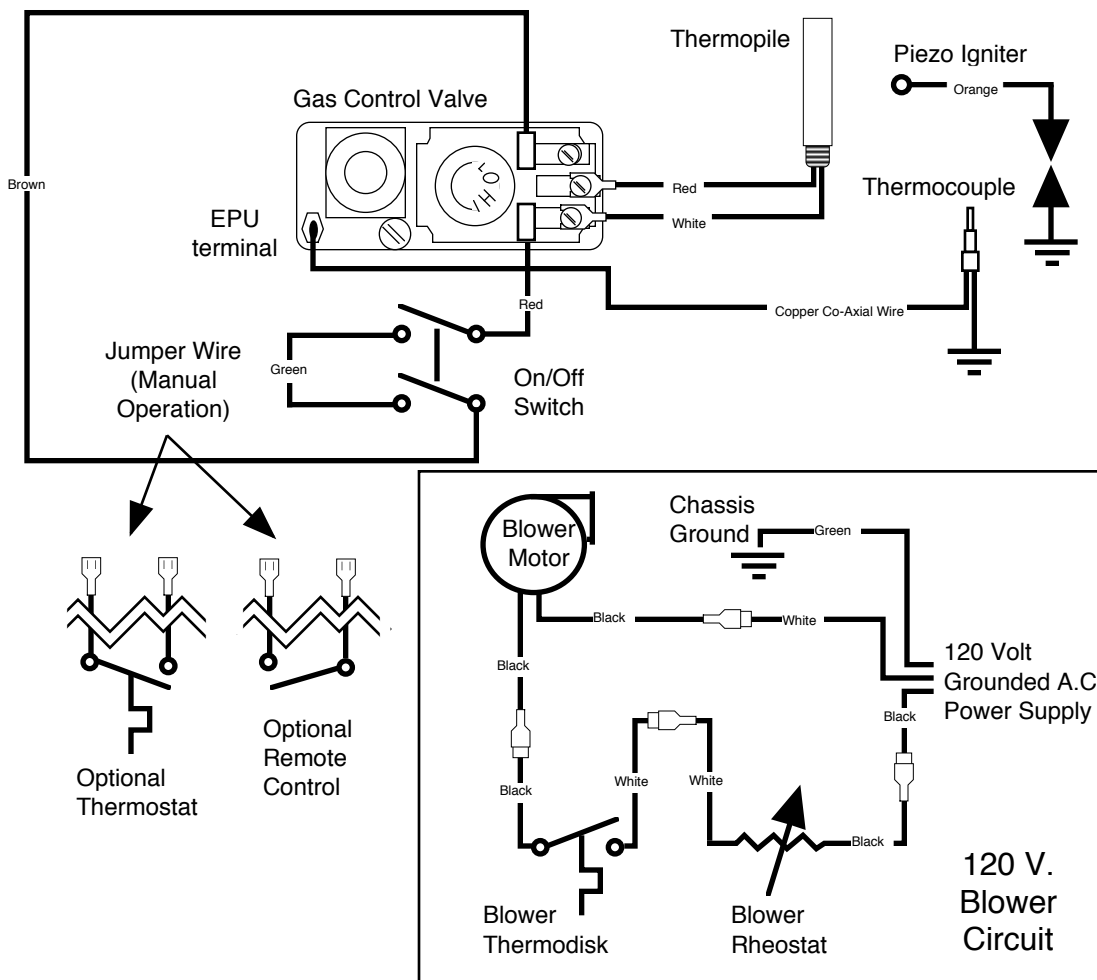

Replacement Parts:

Blower, Convection	93006080	Orifice, Pilot, .021	91001505
Blower Rheostat w/ Off Position	98900758	Piezo Igniter	98900751
Brick Floor Plate	93006071	Pilot Assembly, LP	93006021
Burner Tube	93006000	Pilot Assembly, NG	93006020
Control Valve, LP	97300130	Pilot Tube	91001508
Control Valve, NG	97300120	Power Cord, With Molex Connector	99300656
Conversion Parts, LP	93006030	Pressure Relief Doors	91001541
Conversion Parts, NG	93006031	Regulator, Natural Gas	98900733
Door Gasketing	99900402	Regulator, Propane (LP)	98900734
Glass Gasket, Flat Fiberglass Tape	99900404	Snap Disk	98900720
Glass, Front	93006044	Switch, On/Off	98900747
Glass, Side	99400116	Thermocouple	98900748
Glowing Ember Strip	93006052	Thermopile	98900752
Knob, for Rheostat	99300657	Thermostat, Remote	99300653
Log, Ember Coals	99300114	Thermostat, Wall Mounted	99300650
Log Set, Large (One Piece)	93006050	Wiring Harness	97200307
Manual	93508105		
Orifice, Gas, .125", NG	93006011		
Orifice, Gas #48, LP	93006010		
Orifice, Pilot, .016	91001506		

The listing label is shown below for your records. It can be found on the back panel.

Tested & Listed by  **Beaverton Oregon USA**
OMNI-Test Laboratories, Inc.
Report No. 028-S-14-1



Heritage Bay DVL FS
Listed Gas-Fired
Direct Vent Wall Furnace

Tested and certified by OMNI-Test Laboratories, Inc. to the combustion performance and construction requirements of ANSI Z21.88/CSA 2.23-1998, applicable sections of UL 307b and CAN/CGA 2.17-M91.

The DVL FS is equipped from the factory only for use with Natural Gas. For conversion to LP (Propane) use kit supplied by the manufacturer. This appliance must be installed in accordance with all local codes, if any; if not, in USA follow ANSI Z223.1-1992 and NFPA 54(88), in Canada CAN/CGA B-149. Installation in Manufactured or Mobile Homes must conform with: In USA, Manufactured Home Construction and Safety Standard, Title 24 CFR, Part 3280; In Canada, CSA Z240.4 and Gas-Equipped Recreational Vehicles and Mobile Housing. This appliance is only for use with the type of gas indicated on the rating plate and may be installed in an aftermarket, permanently located, manufactured (mobile) home where not prohibited by local codes. See owner's manual for details. This appliance is not convertible for use with other gases, unless a certified kit supplied by the manufacturer is used. See owner's manual for information on making these changes. This appliance uses a millivolt-type control system consisting of a gas control valve/regulator, a standing pilot burner assembly, a thermopile, a thermocouple, a piezo ignitor, and the ON/OFF switch. THIS UNIT DOES NOT REQUIRE 110 VOLT POWER TO OPERATE. All exhaust gases must be vented outside the structure of the living-area. Combustion air is drawn from outside the living-area structure.

This appliance is a Vented Gas Fireplace Heater. Not for use with Solid Fuel.

WARNING: Improper installation, adjustment, alteration, service or maintenance can cause injury or property damage. Refer to the owner's information manual provided with this appliance. For assistance or additional information consult a qualified installer, service agency or the gas supplier.

WARNING: Operation of this appliance when not connected to a properly installed and maintained venting system can result in carbon monoxide (CO) poisoning and possible death.

Installation and repair should be performed by a qualified service person. The appliance should be inspected before use and at least annually by a qualified service person. More frequent cleaning may be required where excessive lint from material like carpeting and bedding is present. The control compartment, the burner compartment and all circulating air passageways of the appliance must be kept clean and clear at all times.

This appliance must be properly connected to a venting system in accordance with the manufacturer's installation instructions.

This vented gas fireplace heater is not for use with air filters.

Due to high temperatures, the appliance should be located out of traffic and away from furniture and draperies.

Children and adults should be alerted to the hazards of high surface temperature and should stay away to avoid flesh burns or clothing ignition.

Young children should be carefully supervised at all times when they are in the same room as the appliance.

CAUTION: Hot while in operation. Do not touch. Keep children, clothing, furniture, gasoline and other liquids having flammable vapors away.

CAUTION: Do not operate this appliance with glass removed, cracked or broken. Replacement of the panel(s) should be done by a licensed or qualified service person.

Use Simpson DURA-VENT direct vent system (Model GS) to vent this appliance to the exterior.

Minimum Clearances to Combustibles			
Unit to Sidewall	10"	Alcove Min. Height	60" / 1520mm
Unit to Backwall	4" / 100mm	Alcove Max. Depth	48" / 1220mm
Unit to Cornerwall	4" / 100mm	Alcove Min Width	
Front of Unit	36" / 910mm		

FAN TYPE VENTED CIRCULATOR Blower Electrical Rating: 115V, 1.5 Amps, 60 Hz, 150 Watts	Steady State Efficiency Up to 78% (blowers on) Output Capacity Rating Up to 33,970 (blowers on)
---	--

	L.P.	N.G.		L.P.	N.G.
Input Rate on "HI" (BTU/Hr)	43,000	43,000	Minimum Inlet Pressure (inches W.C.)	11.5"	5.5"
Input Rate on "LO" (BTU/Hr)	23,000	23,000	Maximum Inlet Pressure (inches W.C.)	13"	7"
Maximum Output (BTU/Hr)	33,970	33,540	Manifold Pressure on "HI" (inches W.C.)	11"	3.5"
Main Burner Orifice (DMS)	#48	.125"	Manifold Pressure on "LO" (inches W.C.)	2.7"	1"

This appliance is equipped for installation in Canada up to 4500 ft. (1370 m) with certain vent configurations. See owner's manual for restrictions on vent configurations.

In USA, this appliance is equipped for installation from 0-2000 ft. (0-610 m). For altitudes above 2,000 feet, the vent configuration, orifice, or combination of both may need to be changed. See owner's manual for information on making these changes.

Manufacture	■ 1998	■ Jan.	■ Apr.	■ Jul.	■ Oct.	 10850 117th Pl. N.E. Kirkland, WA 98033
Date:	■ 1999	■ Feb.	■ May	■ Aug.	■ Nov.	
	■ 2000	■ Mar.	■ Jun.	■ Sep.	■ Dec.	

IGN

To register your TRAVIS INDUSTRIES, INC. 7 Year Warranty, complete the enclosed warranty card and mail it within **ten (10)** days of the appliance purchase date to: TRAVIS INDUSTRIES, INC., 10850 117th Place N.E., Kirkland, Washington 98033. TRAVIS INDUSTRIES, INC. warrants this gas appliance (appliance is defined as the equipment manufactured by Travis Industries, Inc.) to be defect-free in material and workmanship to the original purchaser from the date of purchase as follows:

Years 1 & 2 - COVERAGE: PARTS & LABOR

Burner Assembly:

Burner, Burner Pan, Air Shutter Assembly, Main Burner Orifice

Firebox Assembly:

Adjustable Air Restrictor, Pressure Relief Mechanisms (direct vents only), Glass Attachment Mechanism

Gas Control Assembly

Adjustable control valve, millivolt wiring and connectors (located within the metal heater structure), thermopile, thermocouple, pilot hood, orifices, pilot gas line, piezo ignitor

Ceramic Glass

Glass (breakage from thermal shock)

Ceramic Logs

Log Set, Coals, Ember Strip (Steel Fiber)

Gold Plating

Gold or Nickel Door, Optional Grill (see "Conditions and Exclusions" # 9)

Electrical Assembly:

Blower, wiring harness, snap discs, rheostat speed control

Accessories

Legs, Pedestal, Panels, Cast Firebacks, Shell Assembly

Convection Heat Exchanger

Re-Installation Allowance

In cases where heater must be removed from home for repairs, a partial cost of re-installation is covered (pre-authorization required)

One-Way Freight Allowance

One-way freight allowance on pre-authorized repair done at factory is covered.

Exclusions: Paint, Gasketing

Years 3 THROUGH 5 - COVERAGE: PARTS & LABOR

Burner Assembly:

Burner, Burner Pan, Air Shutter Assembly, Main Burner Orifice

Firebox Assembly:

Adjustable Air Restrictor, Pressure Relief Mechanisms (direct vents only), Glass Attachment Mechanism

Convection Heat Exchanger

One-Way Freight Allowance

One-way freight allowance on pre-authorized repair done at factory is covered.

Exclusions: Paint, Gasketing, Electrical Assembly, Gas Control Assembly, Ceramic Glass, Ceramic Logs, Gold & Nickel Plating, Accessories, Re-Installation Allowance

Years 6 & 7 - COVERAGE: PARTS ONLY

Burner Assembly:

Burner, Burner Pan, Air Shutter Assembly, Main Burner Orifice

Firebox Assembly:

Adjustable Air Restrictor, Pressure Relief Mechanisms (direct vents only), Glass Attachment Mechanism

Exclusions: Paint, Gasketing, Electrical Assembly, Gas Control Assembly, Ceramic Glass, Ceramic Logs, Gold & Nickel Plating, Accessories, Convection Heat Exchanger, Re-Installation Allowance, One-Way Freight Allowance, Labor

CONDITIONS & EXCLUSIONS

- This new gas appliance must be installed by a qualified gas appliance technician. It must be installed, operated, and maintained at all times in accordance with the instructions in the Owner's Manual. Any alteration, willful abuse, accident, neglect, or misuse of the product shall nullify this warranty.
- This warranty is nontransferable, and is made to the ORIGINAL purchaser, provided that the purchase was made through an authorized TRAVIS dealer.
- Discoloration and some minor expansion, contraction, or movement of certain parts and resulting noise, is normal and not a defect and, therefore, not covered under warranty. The installer must ensure the appliance is burning as per the rating tag at the time of installation. Over-firing (operation above the listed BTU rate) of this appliance can cause serious damage and will nullify this warranty.
- The warranty, as outlined within this document, does not apply to the chimney components or other Non-Travis accessories used in conjunction with the installation of this product. If in doubt as to the extent of this warranty, contact your authorized TRAVIS retailer before installation.
- Travis Industries will not be responsible for inadequate performance caused by environmental conditions such as nearby trees, buildings, roof tops, wind, hills or mountains or negative pressure or other influences from mechanical systems such as furnaces, fans, clothes dryers, etc.
- This Warranty is void if:
 - The unit has been operated in atmospheres contaminated by chlorine, fluorine or other damaging chemicals.
 - The unit is subject to submersion in water or prolonged periods of dampness or condensation.
 - Any damage to the unit, combustion chamber, heat exchanger or other components due to water, or weather damage which is the result of, but not limited to, improper chimney/venting installation.
- Exclusions to this 7 Year Warranty include: injury, loss of use, damage, failure to function due to accident, negligence, misuse, improper installation, alteration or adjustment of the manufacturer's settings of components, lack of proper and regular maintenance, damage incurred while the appliance is in transit, alteration, or act of God.
- This 7 Year warranty excludes damage caused by normal wear and tear, such as paint discoloration or chipping, worn or torn gasketing, corroded or cracked logs, embers, etc. Also excluded is damage to the unit caused by abuse, improper installation, modification of the unit, drilling of the orifices, or the use of fuel other than that for which the unit is configured. Units are shipped for natural gas and must be converted to propane using the included conversion kit. Confirm fuel configuration with your installer.
- Damage to gold, nickel, or brass surfaces caused by fingerprints, scratches, melted items, or other external sources left on the surface is not covered in this warranty. Damage from the use of cleaners other than denatured alcohol on gold or nickel is not covered in this warranty. Damage from the use of abrasive cleaners on brass is not covered in this warranty.
- TRAVIS INDUSTRIES, INC. is free of liability for any damages caused by the appliance, as well as inconvenience expenses and materials. Incidental or consequential damages are not covered by this warranty. In some states, the exclusion of incidental or consequential damage may not apply.
- This warranty does not cover any loss or damage incurred by the use or removal of any component or apparatus to or from the gas appliance without the express written permission of TRAVIS INDUSTRIES, INC. and bearing a TRAVIS INDUSTRIES, INC. label of approval.
- Any statement or representation of TRAVIS products and their performance contained in TRAVIS advertising, packaging literature, or printed material is not part of this 7 year warranty.
- This warranty is automatically voided if the appliance's serial number has been removed or altered in any way. If the appliance is used for commercial purposes, it is excluded from this warranty.
- No dealer, distributor, or similar person has the authority to represent or warrant TRAVIS products beyond the terms contained within this warranty. TRAVIS INDUSTRIES, INC. assumes no liability for such warranties or representations.
- Travis Industries will not cover the cost of the removal or re-installation of hearths, facing, mantels, venting or other components.
- If for any reason any section of this warranty is declared invalid, the balance of the warranty remains in effect and all other clauses shall remain in effect.
- THIS 7 YEAR WARRANTY IS THE ONLY WARRANTY SUPPLIED BY TRAVIS INDUSTRIES, INC., THE MANUFACTURER OF THE APPLIANCE. ALL OTHER WARRANTIES, WHETHER EXPRESS OR IMPLIED, ARE HEREBY EXPRESSLY DISCLAIMED AND PURCHASER'S RECOURSE IS EXPRESSLY LIMITED TO THE WARRANTIES SET FORTH HEREIN.**

IF WARRANTY SERVICE IS NEEDED:

- If you discover a problem that you believe is covered by this warranty, you **MUST REPORT** it to your TRAVIS dealer **WITHIN 30 DAYS**, giving them proof of purchase, the purchase date, and the model name and serial number.
- Travis Industries has the option of either repairing or replacing the defective component.
- If your dealer is unable to repair your appliance's defect, he may process a warranty claim through TRAVIS INDUSTRIES, INC., including the name of the dealership where you purchased the appliance, a copy of your receipt showing the date of the appliance's purchase, and the serial number on your appliance. At that time, you may be asked to ship your appliance, freight charges prepaid, to TRAVIS INDUSTRIES, INC. TRAVIS INDUSTRIES, INC., at its option, will repair or replace, free of charge, your TRAVIS appliance if it is found to be defective in material or workmanship within the time frame stated within this 7 year warranty. TRAVIS INDUSTRIES, INC. will return your appliance, freight charges (years 1 to 5) prepaid by TRAVIS INDUSTRIES, INC., to your regional distributor, or dealership.
- Check with your dealer in advance for any costs to you, when arranging a warranty call. Dealers may require you to pay a service or trip charges for any warranty work. This charge can vary from store to store.

LP Conversion Instructions

Install the conversion kit prior to installing the gas line to ensure proper gas use.

- 1 Open the door (see page 16). Remove the logs, ember strips, and kibbles (if installed - page 17)
- 2 Remove the burner (see illustration below).

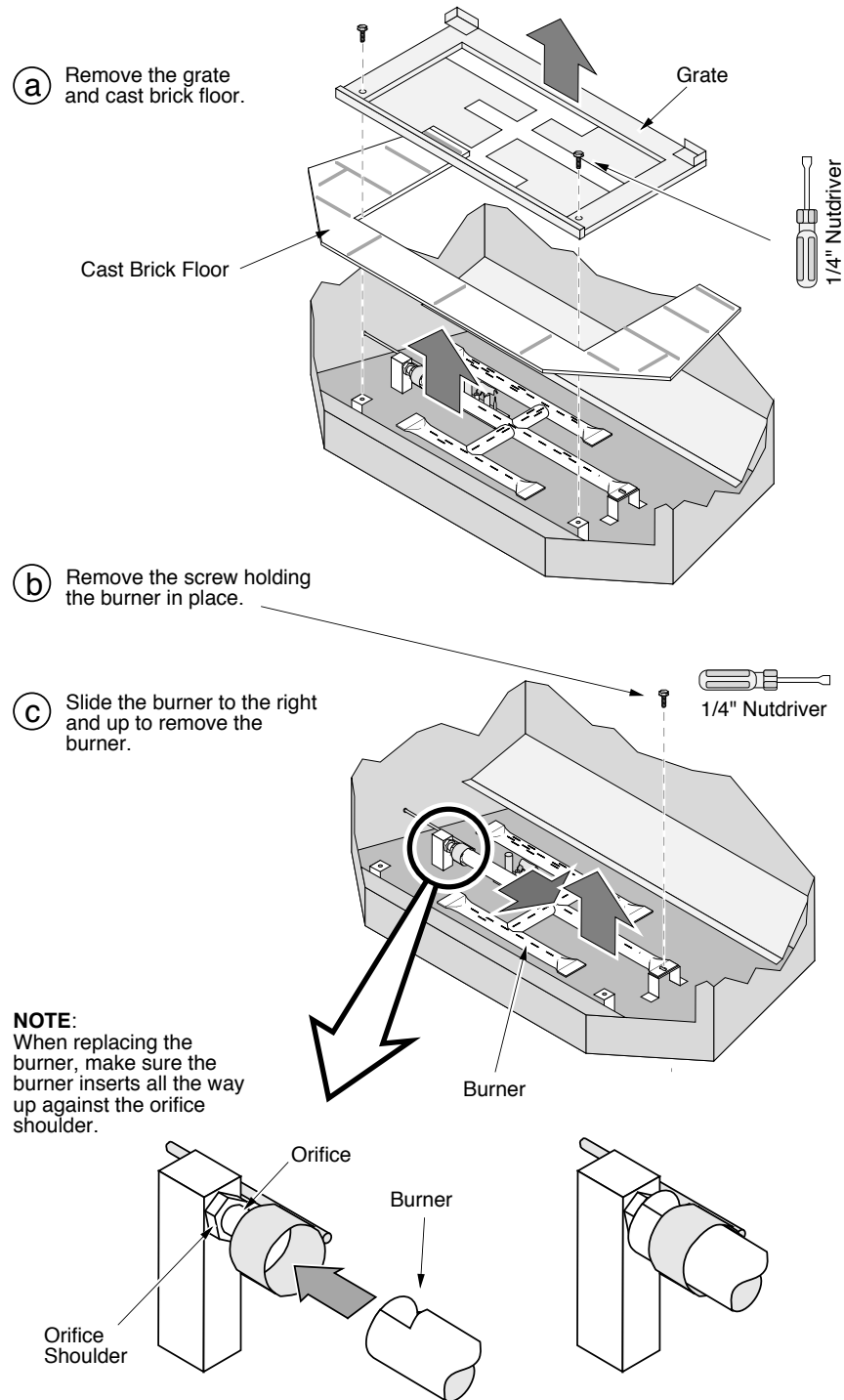

- 3 Follow the directions below to remove the natural gas orifice. Apply thread sealant to the LP orifice (#48 - it has "48" stamped on it) and tighten in place with a 1/2" open end wrench. Slide the adjustable shutter back in place over the orifice.

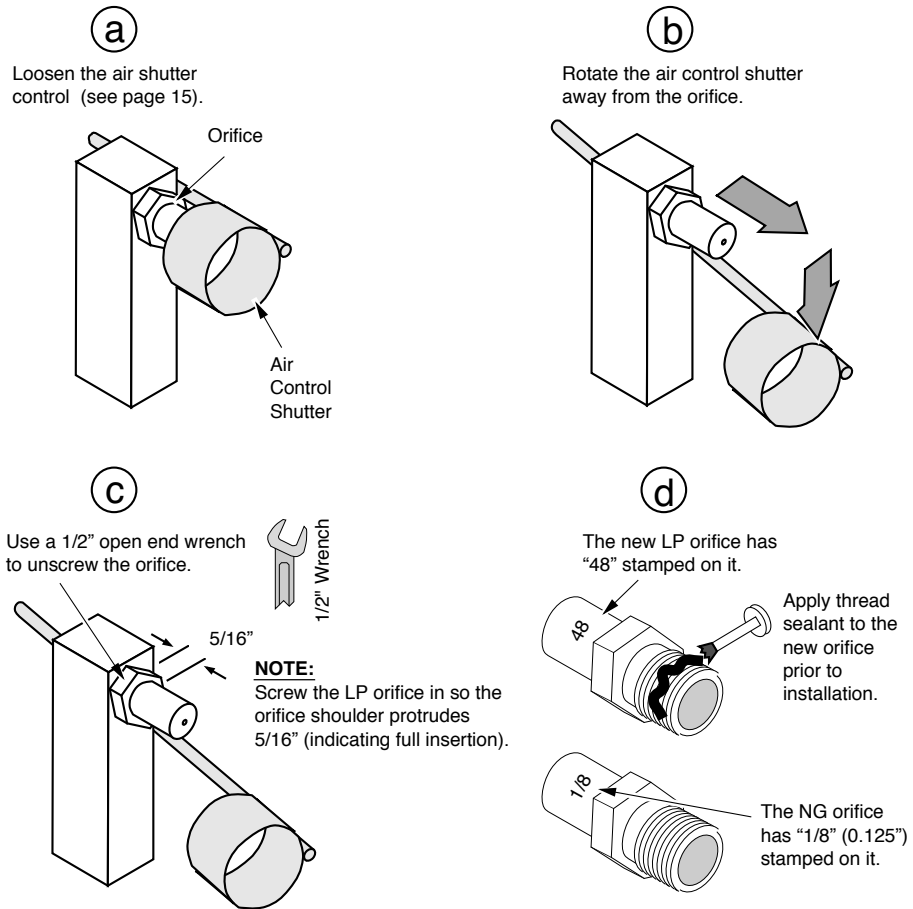

- 4 Remove the pilot orifice following the instructions below. Replace with the propane pilot orifice. The propane conversion kit includes a .016" (labeled LP 16) or .011" (labeled LP 11) pilot orifice. The .016" orifice is preferred because it allows for greater pilot adjustment.

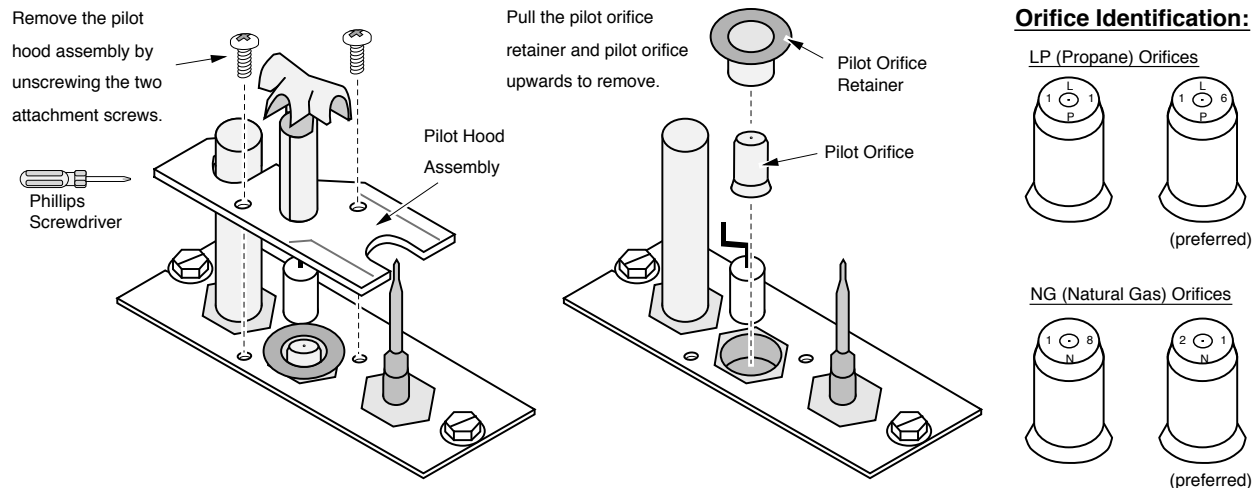

- 5 Install the logs and embers.
- 6 Shut the door.
- 7 Remove the regulator from the front of the gas control valve. Replace with the propane regulator, using the new gasket and screws included with the regulator. **NOTE: Leak test this area after the heater is installed, gas is connected, and the main burner is lit.**

Align the regulator gasket so it is flat and the two tabs fit through the two holes on the gasket.

NOTE: These holes strip easily. Use a hand screwdriver and tighten each screw evenly.

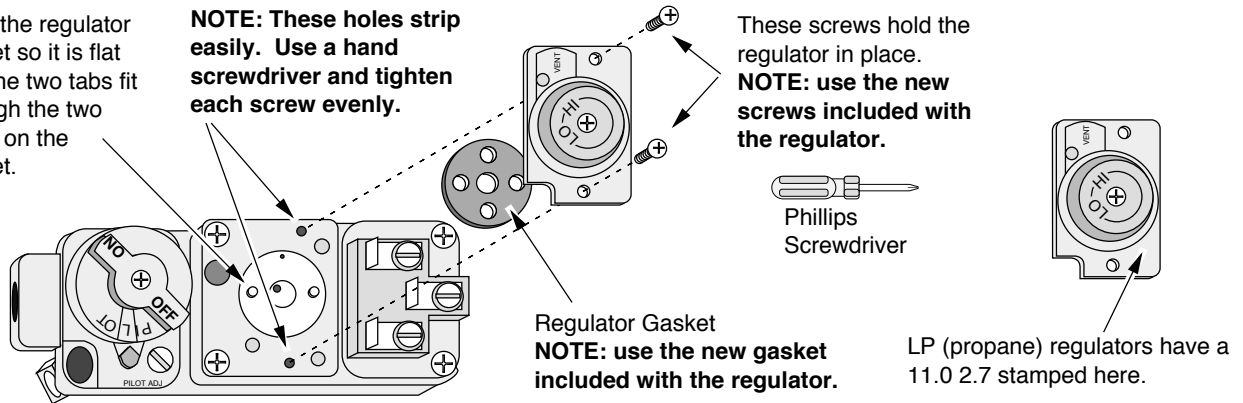

- 8 Place the included propane label over the natural gas label on top of the gas control valve.

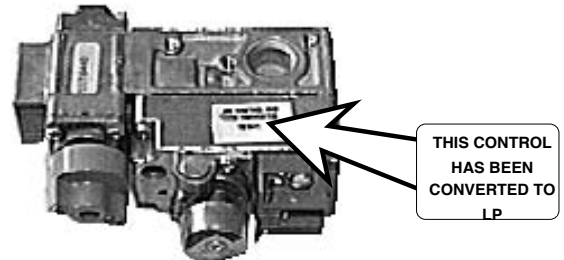

- 9 Make the gas line connection, start the heater and thoroughly leak-test all gas connections and the regulator. Check the pilot. Adjust if necessary.

The pilot flame should touch only the top 3/8" of the thermopile. Adjust the pilot up or down as necessary.

To adjust the pilot flame, remove the cover screw and gasket and turn the needle valve (**NOTE: if the needle valve is totally unscrewed, gas will come out of this port**). Clockwise lowers the flame while counter-clockwise raises it. Replace the cover screw and gasket.

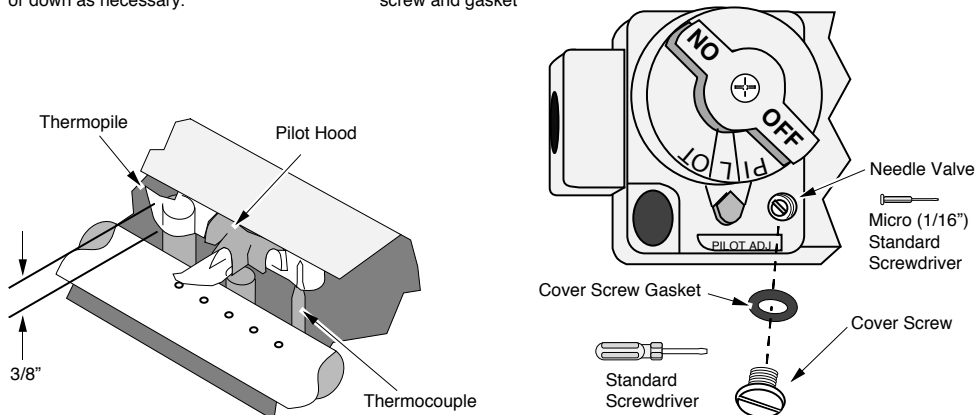

Thermostat (Part # 99300650)

- ! Do not connect 120 VAC to the gas control valve or wiring of this unit.
- 1 Route the thermostat wire through the back of the right side panel (there is a hole beneath the on/off switch) and attach to the on/off switch (see the illustration below).

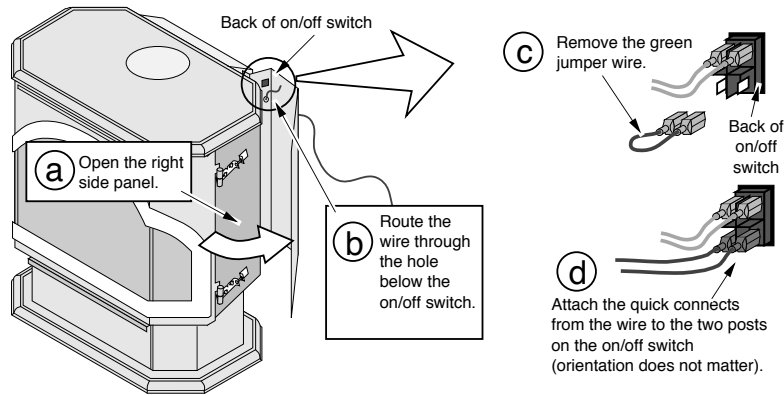

- 2 Pull through all the slack on the wire (you may wish to wrap the wire in electrical tape to prevent damage to the wire). Determine a location for the thermostat that is within range of the 50' length of thermostat wire. It should be centralized in the room and away from the heater. The wire may be routed externally on the wall or behind the wall (preferred).
- 3 Install the thermostat following the directions below.

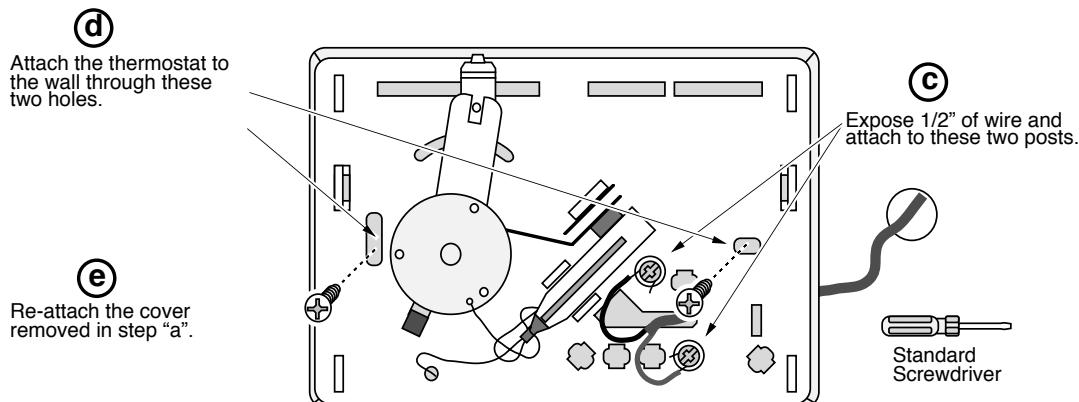
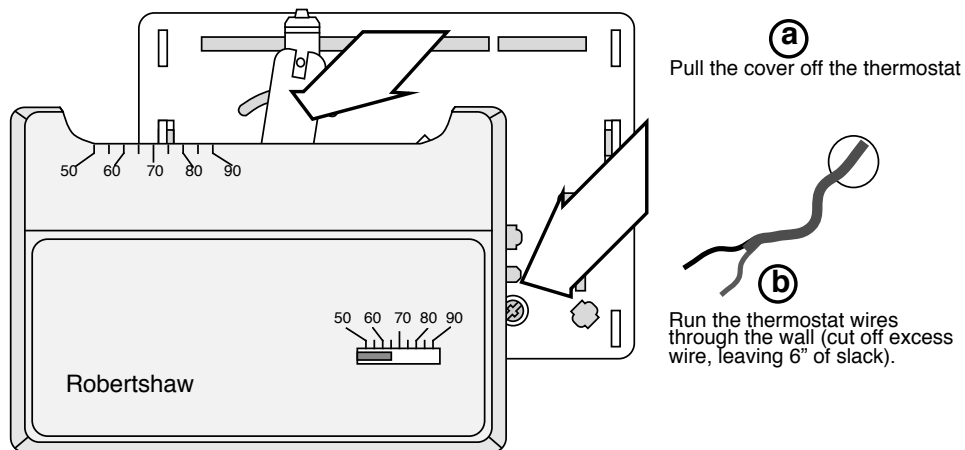

Remote Thermostat (part # 99300653)

- ! Do not connect 110-120 VAC to the gas control valve or wiring system of this unit.
- Follow the instructions included with the remote thermostat for installation.

Using the Remote Thermostat

The remote thermostat has a 1 to 2 minute lag time between the time the thermostat is turned up and the heater turns on. Included with the remote thermostat is a set of instructions that details the operating characteristics of this optional component.

Gold Grill (part # 93005036)

Follow the directions below to install the optional gold grill.

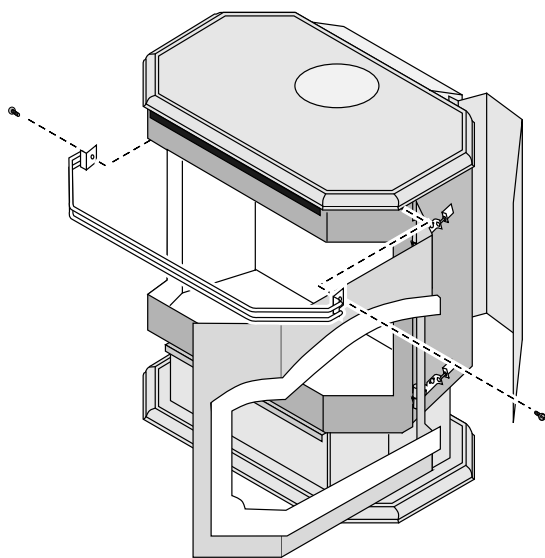

Open the door.

Remove the black grill by removing the two screws holding it in place.

Attach the gold grill with the screws removed.

To prevent marring of the gold surface, clean the grill with denatured alcohol and a soft cloth.

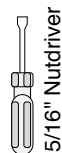

Gold Door (part # 99300212)

Follow the directions below to install the optional gold door.

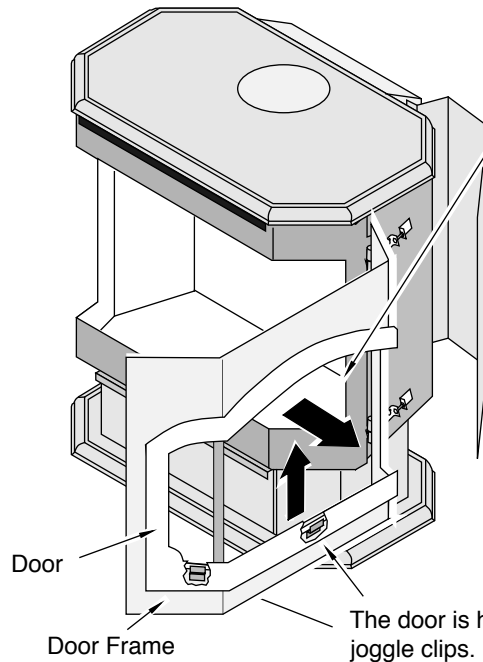

Remove the black door by sliding it up and off the door frame.

Slide the gold door onto the door frame.

HINT: align the bottom joggle clips over the brackets on the door and slide into place. Then lift up slightly on the door to attach the upper clips.

WARNING:

Clean the gold surface prior to starting the stove. Any marks left on the gold may become etched-in by the heat of the stove. Use denatured alcohol and a soft cloth to clean.

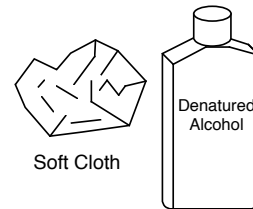

Garland Fireback (part # 99900140)

Follow the directions below to install the optional firebrick.

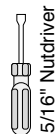
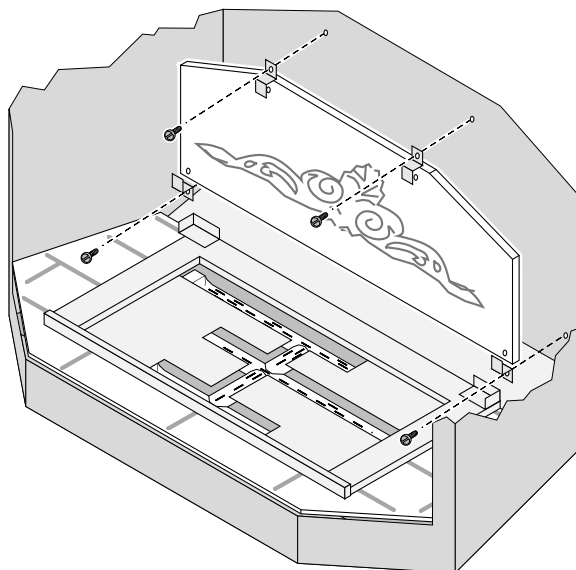

Remove the four screws on the back wall of the firebox and discard.



Install the fireback clips into the lower holes using the screws included with the fireback. Place the fireback on the bottom clips. Install the fireback clips into the upper holes using the screws included with the fireback. Do not fully tighten - the fireback should have space to expand and contract.



ADDENDUM #1 Class A Chimney Conversion Kit

Simpson DuraVent provides a conversion kit for those wishing to use an existing wood stove chimney to vent this direct vent stove. The illustration below gives an overview of this type of installation. See the instructions included with the kit for details.

- ! The conversion kit does not work on interior masonry chimneys.
- ! Do not exceed the maximum vertical rise (see the section "Approved Vent Configurations" starting on page 9) allowable. Remember to set the restrictor position to the correct position (based upon the vertical rise height - see the chart on page 10).

Chimney Conversion Kit A (# 931)

Metalbestos 6" I.D.
Security Chimneys 6" I.D.
Jacks-Evans 6" I.D.
Hart & Cooley 6" I.D.
Pro-Jet 6" I.D.

Chimney Conversion Kit B (# 932)

Simpson Dura-Vent 6" I.D.
Air-Jet 6" I.D.
Metal-Fab 6" and 7" I.D.
Amer. Metals 6" & 7" I.D.
Metalbestos 7" and 8" I.D.
Jacks-Evans 7" and 8" I.D.
Hart & Cooley 7" and 8" I.D.
Pro-Jet 7" and 8" I.D.
Security Chimneys 8" I.D.

Chimney Conversion Kit C (# 933)

Simpson Dura-Vent 7" and 8" I.D.
American Metals 8" I.D.
Air-Jet 8" I.D.
Metal-Fab 8" I.D.
American Metals 8" I.D.

Each Kit Contains:

Retro Connector
Retro Vertical Top

Additional Required Equipment:

4" Flex (#711 or U.L. 1777)
Termination (#991)
Co-Axial Sections

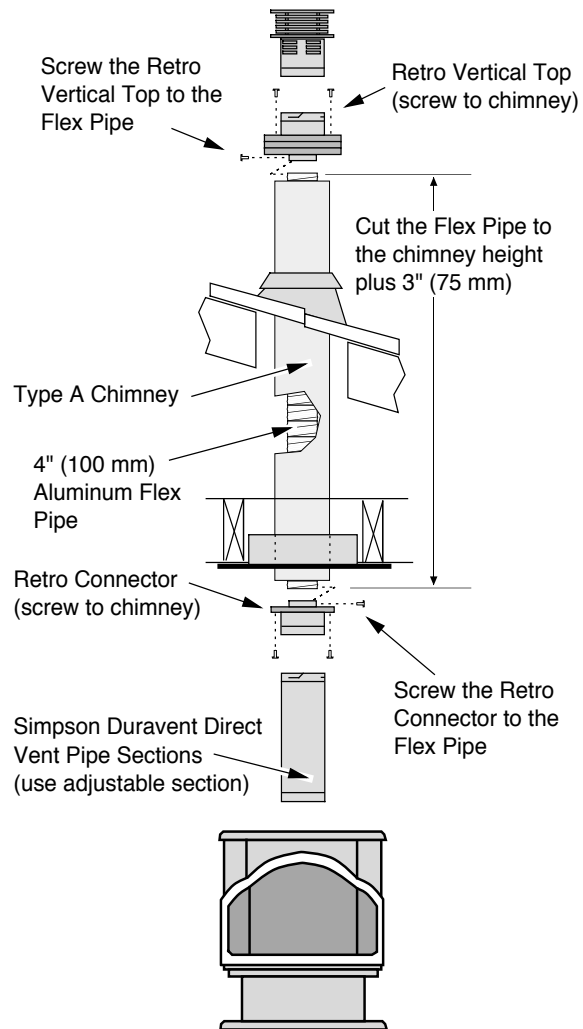

ADDENDUM #2 Interior Masonry Chimney Conversions

- Follow the requirements and use the equipment listed in the illustration to the right to install this appliance into an interior masonry chimney.
 - Maximum vertical rise is 30'
 - Minimum vertical rise is 10'
 - Use the following restrictor positions:
 Position 2 for heights between 8' and 12'
 Position 3 for heights between 12' and 35'
- NOTE:** these restrictor positions are based upon lab tests. The ideal restrictor position may vary slightly.

The entire chimney system must be air-tight. Make sure to seal the flashing, clean-out, and thimble connection, and to inspect the chimney.

Make sure the coaxial pipe maintains a 1" clearance to any combustible. The vent must be sealed air-tight.

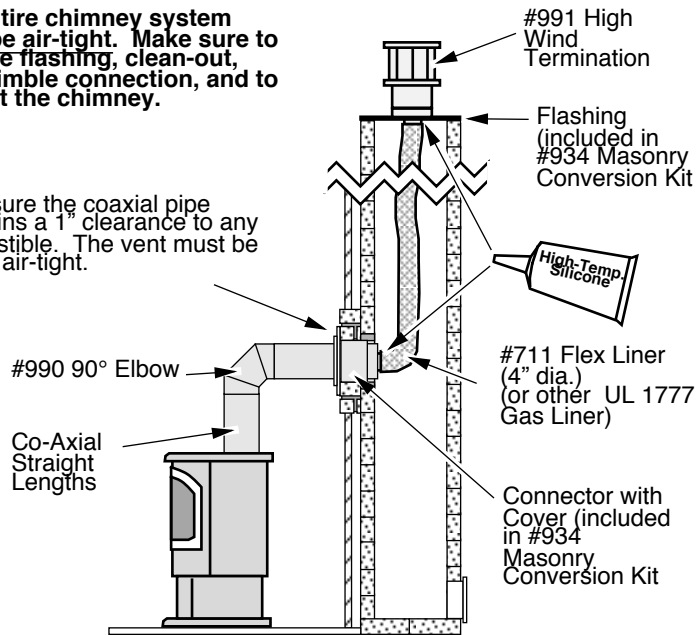

Adjusting the Blower Speed.....	21	Lifting Flames.....	15
Adjusting the Flame Height.....	20	Listing Label (Safety Label).....	26
AFUE.....	5	Log Installation.....	17
Air Shutter Adjustment.....	14	Maintaining Your Stove's Appearance.....	22
Alcoves (see "Heater Placement Req.").....	7	Natural Gas Verses Propane.....	2
Altitude Considerations.....	8	On/Off Operation.....	20
Amperage (of blower).....	5	On/Off Switch (Location).....	18
Blower Speed.....	21	Operating Sounds.....	21
BTU Output.....	5	Order of Installation.....	6
Burn Rate.....	5	Packing Lists.....	6
Burner Installation.....	28	Paint Curing.....	20
Cap (vent termination).....	13	Pilot (starting).....	19
Cleaning Your Heater.....	22	Pilot Flame (Location).....	18
Clearances.....	6	Pressure (of gas).....	7
Condensation.....	20	Purging Gas Line (with door open).....	14
Controls.....	18	Restrictor Adjustment.....	9
Dimensions.....	5	Safety Label.....	26
Door Opening.....	16	Safety Precautions.....	2
Efficiency.....	5	Silicone Vent Sections.....	8
Elbows.....	9	Snorkel Terminations.....	8
Electrical Specifications.....	5	Sounds.....	21
Emissions.....	5	Starting The Pilot Flame.....	19
Flame Height.....	15	Starting the Heater for the First Time.....	20
Floor Protection Requirements.....	7	Stove Placement Requirements.....	7
Fuel.....	5	Table of Contents.....	4
Fumes.....See Inst. On Cover		Thermostat Installation.....	31
Gas Control Valve (Location).....	18	Troubleshooting Table.....	23
Gas Inlet Installation.....	7	Vent Configurations.....	9
Gas Leak.....See Inst. on Cover		Vent Part #'s.....	8
Gas Line Connection.....	7	Vent Requirements.....	8
Gas Smell.....See Inst. on Cover		Vertical Vent Termination Requirements.....	13
Heating Capacity.....	5	Warranty.....	27
High Wind Vertical Terminations.....	8	Water (on glass - see starting the heater).....	20
Horizontal Vent Termination Requirements.....	13	Wiring Diagram.....	25
How to Measure Vent Lengths.....	9	Yearly Service Procedure.....	22
Installation Options.....	5		
Installation Preparation.....	6		
Leaking Gas.....See Inst. on Cover			