

864 TRV GS2

(with screen)

Installation Manual



⚠ WARNING: FIRE OR EXPLOSION HAZARD

Failure to follow safety warnings exactly could result in serious injury, death, or property damage.

- Do not store or use gasoline or other flammable vapors and liquids in the vicinity of this or any other appliance.
- **WHAT TO DO IF YOU SMELL GAS**
 - Do not try to light any appliance.
 - Do not touch any electrical switch; do not use any phone in your building.
 - Leave the building immediately
 - Immediately call your gas supplier from a neighbor's phone. Follow the gas supplier's instructions.
 - If you cannot reach your gas supplier, call the fire department.
- Installation and service must be performed by a qualified installer, service agency or the gas supplier.



HOT GLASS WILL CAUSE BURNS

DO NOT TOUCH GLASS UNTIL COOLED

NEVER ALLOW CHILDREN TO TOUCH GLASS

A barrier designed to reduce the risk of burns from the hot viewing glass is provided with this appliance and shall be installed for the protection of children and other at-risk individuals.

Tested and Listed by



Intertek

Report # B0516PRT-001
ANSI Z21.88-2014
CSA 2.33-2014

- **Built-In Direct Vent Fireplace**
- **Natural Gas or Propane**
- **Residential or Mobile Home**

This appliance may be installed in an aftermarket, permanently located, manufactured home (USA only) or mobile home, where not prohibited by local codes.

This appliance is only for use with the type of gas indicated on the rating plate. A conversion kit is supplied with the appliance.

INSTALLER: Leave this manual with the appliance.

French language manuals at travisindustries.com

CONSUMER: Retain this manual for future reference.

Manuels de langue Française à travisindustries.com

Overview

This manual details the installation requirements for the 864 TRV GS2 fireplace. For operating and maintenance instructions, refer to the 864 TRV GS2 Owner's Manual.

Listing Details

This appliance was listed by Intertek Test Labs to ANSI Z21.88. The listing label is attached to the appliance near the gas control valve. A copy is shown to the right.

Massachusetts Approval

This manual has been submitted to the Massachusetts Board of State Examiners of Plumbers and Gas Fitters

National Fireplace Institute



We suggest that our gas hearth products be installed and serviced by professionals who are certified in the U.S. by the National Fireplace Institute® (NFI) as NFI Gas Specialists.

www.nficertified.org

<p>Minimum Clearances to Combustibles</p> <table style="width: 100%; border-collapse: collapse;"> <tr> <td style="width: 33%;">Fireplace to Adjacent Wall</td> <td style="width: 33%;">1" (26mm)</td> <td style="width: 33%;">Top to Enclosure (from Stand-Offs)</td> <td style="width: 33%;">0" (0mm)</td> </tr> <tr> <td>Wood Floor Beneath Fireplace</td> <td>0" (0mm)</td> <td>Sides to Enclosure</td> <td>0.5" (13mm)</td> </tr> <tr> <td>Back to Enclosure</td> <td>0.5" (13mm)</td> <td>Base of Fireplace to a Mantel</td> <td>See Owner's Manual</td> </tr> </table>	Fireplace to Adjacent Wall	1" (26mm)	Top to Enclosure (from Stand-Offs)	0" (0mm)	Wood Floor Beneath Fireplace	0" (0mm)	Sides to Enclosure	0.5" (13mm)	Back to Enclosure	0.5" (13mm)	Base of Fireplace to a Mantel	See Owner's Manual	<p>FAN TYPE VENTED CIRCULATOR</p> <p>Blower Electrical Rating: 115V, 1.5 Amps, 60 Hz, 150 Watts Part No. 228-10077 / 228-10078 fan or blower assembly may be used. DANGER! Risk of Electric Shock. Disconnect power before servicing unit.</p> <table style="width: 100%; border-collapse: collapse;"> <tr> <td style="width: 33%;">Input Rate on "Hr" (BTU/HR)</td> <td style="width: 33%;">L.P. 31,000</td> <td style="width: 33%;">M.G. 37,000</td> <td style="width: 33%;">N.G. 55,000</td> </tr> <tr> <td>Input Rate on "LO" (BTU/HR)</td> <td>8,000</td> <td>10,000</td> <td>13,000</td> </tr> <tr> <td>Office Size - Front (DMS)</td> <td>#56</td> <td>#49</td> <td>#7</td> </tr> <tr> <td>Office Size - Rear (DMS)</td> <td>#57</td> <td>#49</td> <td>#3.5</td> </tr> </table> <p>This appliance is equipped for use only at altitudes 0-2,000 feet (0-610m) in the USA, in Canada, 0-4,500 feet (0-1370m). For altitudes above 2,000 feet, the vent configuration, orifice, or combination of both may need to be changed. See owner's manual for information on making these changes.</p>	Input Rate on "Hr" (BTU/HR)	L.P. 31,000	M.G. 37,000	N.G. 55,000	Input Rate on "LO" (BTU/HR)	8,000	10,000	13,000	Office Size - Front (DMS)	#56	#49	#7	Office Size - Rear (DMS)	#57	#49	#3.5	<p>MANUFACTURE DATE:</p> <table style="width: 100%; border-collapse: collapse;"> <tr> <td><input type="checkbox"/> 2014</td> <td><input type="checkbox"/> Jan.</td> <td><input type="checkbox"/> Apr.</td> <td><input type="checkbox"/> Jul.</td> <td><input type="checkbox"/> Oct.</td> </tr> <tr> <td><input type="checkbox"/> 2015</td> <td><input type="checkbox"/> Feb.</td> <td><input type="checkbox"/> May.</td> <td><input type="checkbox"/> Aug.</td> <td><input type="checkbox"/> Nov.</td> </tr> <tr> <td><input type="checkbox"/> 2016</td> <td><input type="checkbox"/> Mar.</td> <td><input type="checkbox"/> Jun.</td> <td><input type="checkbox"/> Sep.</td> <td><input type="checkbox"/> Dec.</td> </tr> </table> <p style="text-align: right; font-size: small;">Manufactured by: TRAVIS INDUSTRIES HOUSE OF FIRE 12521 Harbour Reach Drive Mukilteo, WA 98275 www.travisproducts.com</p>	<input type="checkbox"/> 2014	<input type="checkbox"/> Jan.	<input type="checkbox"/> Apr.	<input type="checkbox"/> Jul.	<input type="checkbox"/> Oct.	<input type="checkbox"/> 2015	<input type="checkbox"/> Feb.	<input type="checkbox"/> May.	<input type="checkbox"/> Aug.	<input type="checkbox"/> Nov.	<input type="checkbox"/> 2016	<input type="checkbox"/> Mar.	<input type="checkbox"/> Jun.	<input type="checkbox"/> Sep.	<input type="checkbox"/> Dec.
Fireplace to Adjacent Wall	1" (26mm)	Top to Enclosure (from Stand-Offs)	0" (0mm)																																										
Wood Floor Beneath Fireplace	0" (0mm)	Sides to Enclosure	0.5" (13mm)																																										
Back to Enclosure	0.5" (13mm)	Base of Fireplace to a Mantel	See Owner's Manual																																										
Input Rate on "Hr" (BTU/HR)	L.P. 31,000	M.G. 37,000	N.G. 55,000																																										
Input Rate on "LO" (BTU/HR)	8,000	10,000	13,000																																										
Office Size - Front (DMS)	#56	#49	#7																																										
Office Size - Rear (DMS)	#57	#49	#3.5																																										
<input type="checkbox"/> 2014	<input type="checkbox"/> Jan.	<input type="checkbox"/> Apr.	<input type="checkbox"/> Jul.	<input type="checkbox"/> Oct.																																									
<input type="checkbox"/> 2015	<input type="checkbox"/> Feb.	<input type="checkbox"/> May.	<input type="checkbox"/> Aug.	<input type="checkbox"/> Nov.																																									
<input type="checkbox"/> 2016	<input type="checkbox"/> Mar.	<input type="checkbox"/> Jun.	<input type="checkbox"/> Sep.	<input type="checkbox"/> Dec.																																									

864 TRV GS2

864 TRV GSR2

Vented Gas Fireplace Heater

Report No. B0516PRT-001
Control No. 4000515

Intertek
c. ^{us}

Tested to: ANSI Z21.88-2014/CSA 2.33-2014 "Vented Gas Fireplace Heater", CGA 2.17-M91 (R2009) "Gas Burning Heating Appliances for Manufactured Homes", and CSA P4.1-09 Testing method for measuring annual fireplace efficiency.

This appliance must be installed in accordance with local codes, if any; if none, follow the National Fuel Gas Code, ANSI Z223.1/NFPA 54, or Natural Gas and Propane Installation Codes, CSA B149.1.

This appliance must be installed in accordance with the current Standard CAN/CSA Z240 MH, Mobile Housing, in Canada or with the Manufactured Home Construction and Safety Standard, Title 24 CFR, Part 3280, in the United States, or when such a standard is not applicable, ANSINCSCBS A225-1/NFPA 501A, Manufactured Home Installation Standard.

This vented gas fireplace heater is equipped at the factory for use with natural gas. If conversion to propane (LP) is desired, the optional factory conversion kit must be used. 864 TRV GS2: Part No. 250-01720 (SIT) or 225-20224 (P-SE) register kit may be used. 864 TRV GSR2: Part No. 225-20173 (P-SE) register kit may be used.

This appliance is only for use with the type of gas indicated on the rating plate and may be installed in an aftermarket, permanently located, manufactured home (USA only) or mobile home, where not prohibited by local codes. See owner's manual for details. This appliance is not convertible for use with other gases, unless a certified kit is used.

This vented gas fireplace heater is not for use with air filters.

Keep burner and control compartment clean. See installation and operating instructions accompanying appliance.

This appliance must be properly connected to a venting system in accordance with the manufacturer's installation instructions. Use only approved coaxial direct vent system to vent this appliance to the exterior. See owner's manual for approved brands of venting.

If the vent-air intake system is disconnected for servicing or any other reason, it must be resealed and / or reinstalled.

WARNING: Improper installation, adjustment, alteration, service or maintenance can cause injury or property damage. Refer to the owner's information manual provided with this appliance. For assistance or additional information consult a qualified installer, service agency or the gas supplier.

VENTED GAS FIREPLACE HEATER - NOT FOR USE WITH SOLID FUEL

CAUTION: Do not operate this appliance with glass removed, cracked or broken. Replacement of the panel(s) should be done by a licensed or qualified service person

WARNING: Failure to install this appliance per the manufacturer's instructions or failure to use only parts specifically approved with this appliance may result in property damage or personal injury.

Table of Contents

- Overview**2
- Listing Details**2
- Installation Options**6
- Heating Specifications**6
- Dimensions**.....6
- Packing List**.....7
- Additional Items Required**.....7
- Installation Overview**7
- Recommended Installation Procedure**.....7
- Massachusetts Requirements**8
 - Requirements for the Commonwealth of Massachusetts
 - MANUFACTURER REQUIREMENTS 8
- Top Vent or Rear Vent Configuration**9
 - Converting the Fireplace to Top Vent Configuration 9
 - Converting the Fireplace to Top Vent (continued) 10
- Fireplace Placement Requirements**11
 - Clearances 11
 - Raised Fireplaces 11
- Televisions Placed Above the Fireplace**.....12
 - Using a Mantel Between the Fireplace and Television 12
 - Using a Buildout Above Fireplace and Television 13
 - Using a Buildout Below a Television 14
 - Minimum Framing Dimensions - Rear Vent Configuration 15
 - Minimum Framing Dimensions - Top Vent Configuration16
 - Nailing Brackets 17
 - Corner Installations - Rear Vent Configuration 18
 - Corner Installations - Top Vent Configuration 19
- Outdoor Fireplace Installations**20
- Gas Line Requirements**21
 - Fuel 21
 - Gas Line Connection21
 - Gas Inlet Pressure 21
 - Gas Line Location 22
 - Converting Gas Line to the Left Side 22
- Electrical Connection (required)**.....23
- Optional Wall Switch or Thermostat Installation**24
 - Parallel Connection Series Connection 24
- Vent Requirements**25
 - Vent Clearances..... 25
 - Altitude Considerations 25
 - Approved Vent 26
 - Vent Installation..... 26
- Approved Vent Configurations**27
 - Restrictor Position 27
 - Exhaust Restrictor Adjustment..... 27
 - Intake Restrictor Adjustment 28
 - Diffuser Plate Adjustment..... 29
- Rear Vent Configuration with Horizontal Termination (no vertical rise)**.....30
- Rear Vent Configuration with Horizontal Termination (with vertical rise)**.....31
- Rear Vent Configuration with Vertical Termination**32
- Top Vent Configuration with Horizontal Termination**33

- Top Vent Configuration with Vertical Termination**34
- Termination Requirements**.....35
- Hearth Requirements**.....36
- Facing Requirements**37
 - Drywall Installation.....37
 - Facing Overview38
 - Optional Faceplates.....38
 - Thin Facing Installation (tile, marble, or other non-combustible under 1" (25mm) thick)39
 - Thin Facing Installation (tile, marble, under 1" (25mm) thick) - Side View40
 - Thick Facing Installation (stone, brick, or other non-combustible over 1" (25mm) thick)41
 - Thick Facing with Fireplace Xtordinaire (FPX) Arched Faces42
 - Thick Facing Installation - Side View43
- Mantel Requirements**.....44
 - Combustible Mantels44
 - Examples:44
 - Non-Combustible Mantels44
- Installation Example - Build-Out (Dog-House) with Hor. Termination**45
- Installation Example - Build-In with Horizontal Termination**46
- Steps for Finalizing the Installation**.....47
 - Air Shutter Adjustment.....48
- Barrier Removal**49
- Glass Frame Removal and Installation**50
- Glass Frame Removal and Installation (continued)**51
- Log Set Installation**52
 - Log Set Overview52
 - Back Log.....53
 - Right Log53
 - Front Left Log54
 - Left Log.....54
 - Center Twig55
 - Front Ember Chunk55
 - Left Twig56
 - Center Left Twig56
 - Center Log.....57
 - Right Twig.....57
 - Ember Installation.....58
 - Rock Wool Placement58
- LP Conversion Instructions**59
- Fireback Installation**62
- Grill Installation**.....63
- GS2 Remote Installation**.....64
 - Packing List64
 - Warnings.....64
 - Remote Control / Pilot Warnings.....64
 - Base Wiring Diagram.....65
 - GS2 Remote Wiring Diagram66
 - Installation.....67
- Index**78

Safety Warnings

- Failure to follow all of the requirements may result in property damage, bodily injury, or even death.

Young children should be carefully supervised when they are in the same room as the appliance. Toddlers, young children and others may be susceptible to accidental contact burns. A physical barrier is recommended if there are at risk individuals in the house. To restrict access to a fireplace or stove, install an adjustable safety gate to keep toddlers, young children and other at risk individuals out of the room and away from hot surfaces.

Children and adults should be alerted to the hazards of high surface temperature and should stay away to avoid burns or clothing ignition. Do not touch the hot surfaces of the heater. Educate all children of the danger of a high-temperature heater.

Due to the high temperature, the heater should be located out of traffic and away from furniture and draperies.

- This unit must be installed by a qualified installer to prevent the possibility of an explosion.
- This appliance must be installed in accordance with all local codes, if any; if not, in U.S.A. follow ANSI Z223.1 and NFPA 54(88), in Canada follow CSA B149.1.
- A manufactured home (USA only) or mobile home OEM installation must conform with the Manufactured Home Construction and Safety Standard, Title 24 CFR, Part 3280, or, when such a standard is not applicable, the Standard for Manufactured Home Installations, ANSI/NCSCBS A225.1, or Standard for Gas Equipped Recreational Vehicles and Mobile Housing, CSA Z240.4. This appliance may be installed in Manufactured Housing only after the home is site located.
- All exhaust gases must be vented outside the structure of the living-area. Combustion air is drawn from outside the living-area structure. The venting must not be connected to a chimney flue serving a separate solid-fuel burning appliance.
- Notify your insurance company before hooking up this fireplace.
- The instructions in this manual must be strictly adhered to. Do not use makeshift methods or compromise in the installation. Improper installation will void the warranty and safety listing.
- This heater is approved for use with natural gas (NG) or propane (LP). Burning the incorrect fuel will void the warranty and safety listing and may cause an extreme safety hazard. Direct questions about the type of fuel used to your dealer.
- Contact your local building officials to obtain a permit and information on any installation restrictions or inspection requirements in your area.
- If the flame becomes sooty, dark orange in color, or extremely tall, do not operate the heater. Call your dealer and arrange for proper servicing.
- It is imperative that control compartments, screens, or circulating air passageways of the heater be kept clean and free of obstructions. These areas provide the air necessary for safe operation.
- Do not operate the heater if it is not operating properly in any fashion or if you are uncertain. Call your dealer for a full explanation of your heater and what to expect.
- Do not store or use gasoline or other flammable liquids in the vicinity of this heater.
- Do not operate if any portion of the heater was submerged in water or if any corrosion occurs. Immediately call a qualified service technician to inspect the appliance and to replace any part of the control system and any gas control which has been under water.

Safety Warnings (continued)

- Because this heater can be controlled by a thermostat there is a possibility of the heater turning on and igniting any items placed on or near the appliance.
- Light the heater using the built-in igniter. Do not use matches or any other external device to light your heater.
- Never remove, replace, modify or substitute any part of the heater unless instructions are given in this manual. All other work must be done by a trained technician. Don't modify or replace orifices.
- The viewing glass should be opened only for conducting service.
- Allow the heater to cool before carrying out any maintenance or cleaning.
- Operate the heater according to the instructions included in this manual.
- If the main burners do not start correctly turn the gas off and call your dealer for service.
- This unit is not for use with solid fuel.
- Do not place anything inside the firebox (except the optional artwork).
- **Warning:** Do not operate appliance with the glass front removed, cracked or broken. Replacement of the glass should be done by a licensed or qualified service person.
- Do not throw this manual away. This manual has important operating and maintenance instructions that you will need at a later time. Always follow the instructions in this manual.
- Instruct everyone in the house how to shut gas off to the appliance and at the gas main shutoff valve. The gas main shutoff valve is usually next to the gas meter or propane tank and requires a wrench to shut off.
- A barrier designed to reduce the risk of burns from the hot viewing glass is provided with this appliance and shall be installed for the protection of children and other at-risk individuals.
- If the barrier becomes damaged, the barrier shall be replaced with the manufacturer's barrier for this appliance.
- Clothing or other flammable material should not be placed on or near the appliance.
- Any safety screen, guard, or barrier removed for servicing an appliance must be replaced prior to operating the appliance.
- Installation and repair should be done by a qualified service person. The appliance should be inspected before use and at least annually by a professional service person. More frequent cleaning might be required due to excessive lint from carpeting, bedding material, et cetera. It is imperative that control compartments, burners, and circulating air passageways of the appliance be kept clean.
- **Travis Industries, Inc. grants no warranty, implied or stated, for the installation or maintenance of your heater, and assumes no responsibility of any consequential damage(s).**

Proposition 65 Warning: Fuels used in gas, woodburning or oil fired appliances, and the products of combustion of such fuels, contain chemicals known to the State of California to cause cancer, birth defects and other reproductive harm. California Health & Safety Code Sec. 25249.6

Travis Gas Fireplaces, Stoves, and Inserts are protected by one or more of the following patents; U.S. 8,469,021, 7,066,170, 6,602,068, 6,443,726, 6,953,037; Canada 2755517 as well as other U.S. and Foreign Patents pending.

Installation Options

- Residential or Mobile Home
- Straight or Corner Placement
- Flush or Recessed Face
- Raised or Floor Placement
- Internal or External Chase
- Horizontal or Vertical Vent
- Bedroom Approved

Heating Specifications

	Natural Gas	Propane
Approximate Heating Capacity (in square feet)*	450 to 1,400	450 to 1,400
Maximum BTU Input Per Hour	31,000	31,000

* Heating capacity will vary with floor plan, insulation, and outside temperature.

** Efficiency rating is a product thermal efficiency rating determined under continuous operation independent of installed system.

Dimensions

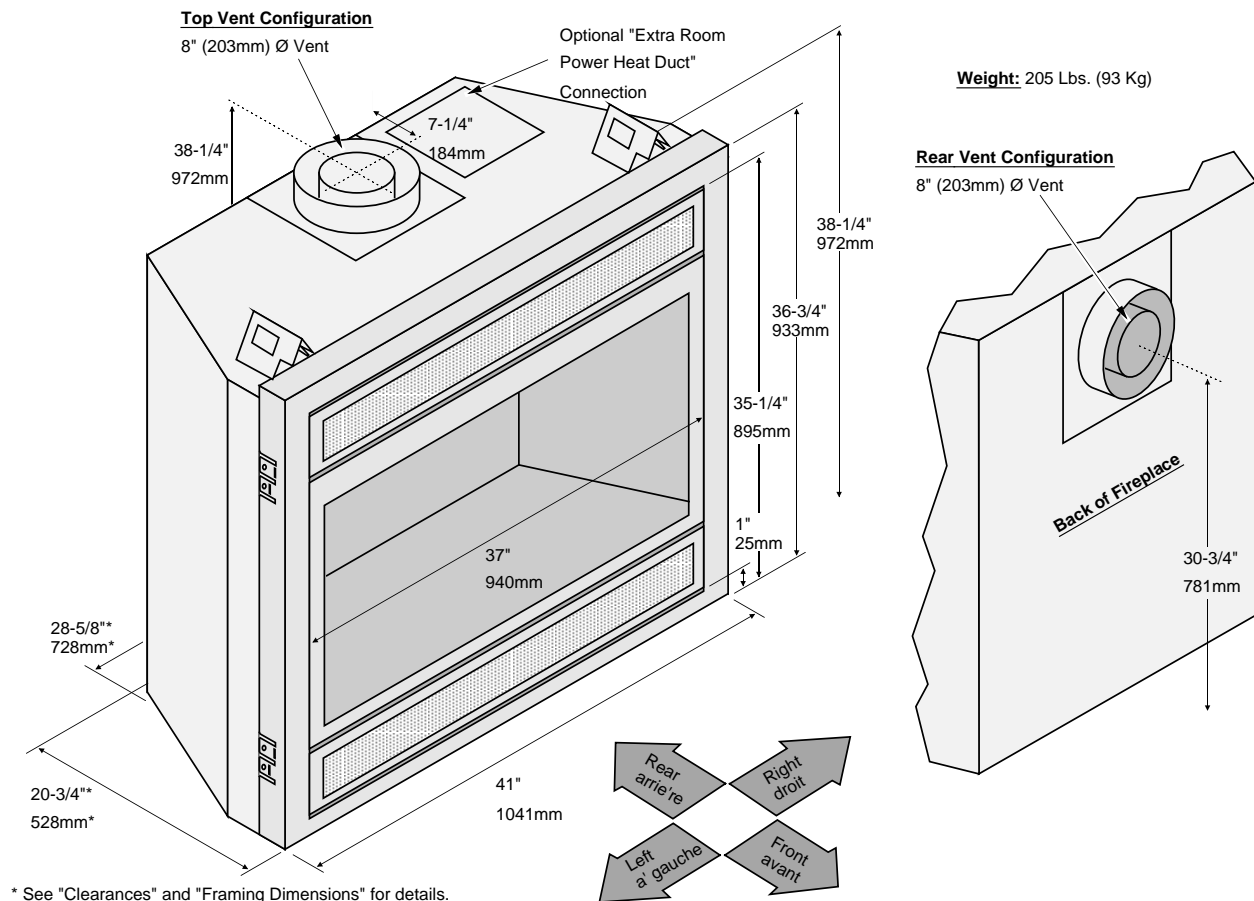

Packing List

- Propane Conversion Kit
- Log Set
- Firestop (sku 93006094)
- On/Off Switch, Cover Plate, and Wire
- (4) AA Batteries, (1) 9v Battery

Additional Items Required

- Direct Vent
- Gas Line Equipment (shutoff valve, pipe, etc.)
- Electrical Equipment (min. 14 gauge, grounded line)

Installation Overview

- All requirements below must be met.

Top Vent Configuration

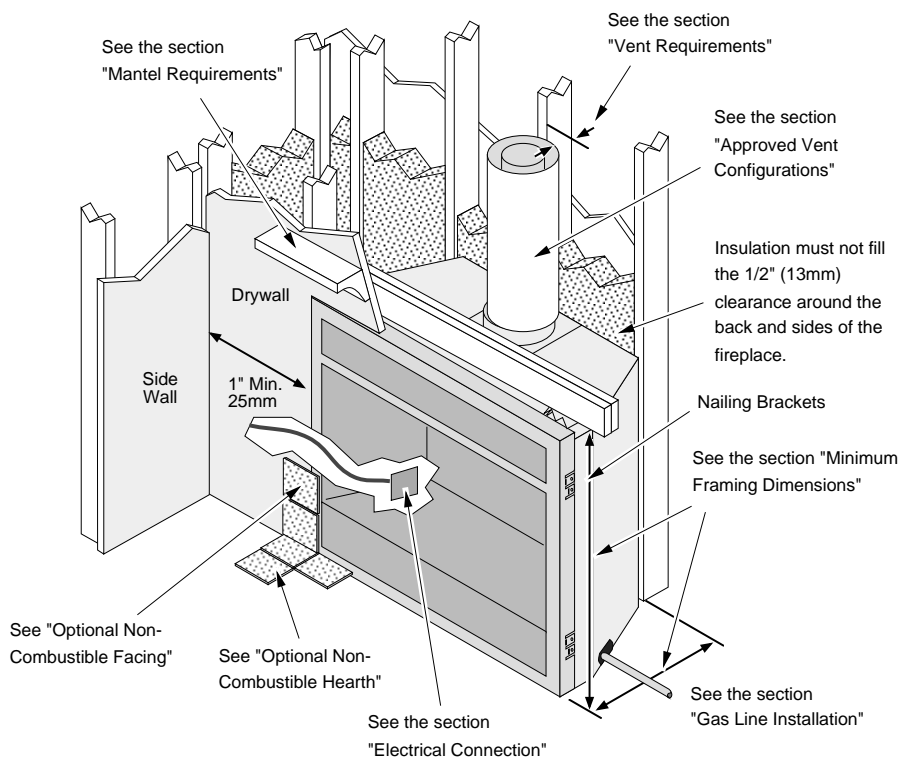

Rear Vent Configuration

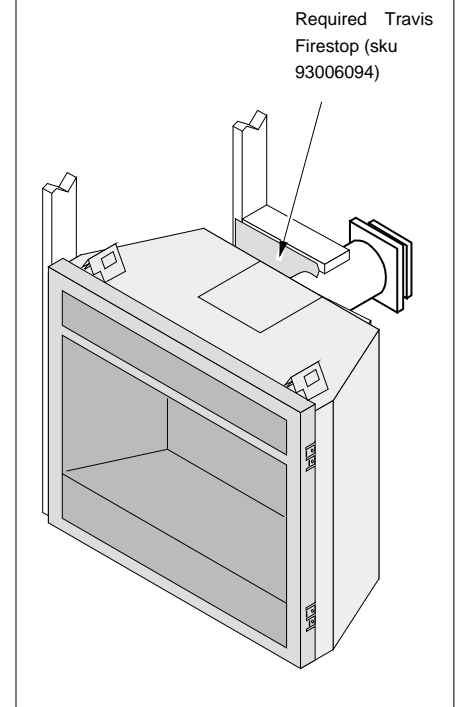

Recommended Installation Procedure

- Frame the opening for the fireplace. Make sure to allow for vent installation.
- This fireplace is designed to accommodate 1/2" (13mm) or 5/8" (16mm) drywall (see "Nailing Brackets" on page 17 for details). Secure the fireplace to the framing.
- Install the vent, gas line and electrical hook-up.
- Install the drywall.
- Install the hearth (if applicable).
- Install the facing (if applicable).
- Install the mantel (if applicable).
- Finalize the installation (see page 47) and install the grill or face.

Massachusetts Requirements

NOTE: The following requirements reference various Massachusetts and national codes not contained in this document.

Requirements for the Commonwealth of Massachusetts

For all side wall horizontally vented gas fueled equipment installed in every dwelling, building or structure used in whole or in part for residential purposes, including those owned or operated by the Commonwealth and where the side wall exhaust vent termination is less than seven (7) feet above finished grade in the area of the venting, including but not limited to decks and porches, the following requirements shall be satisfied:

Installation of Carbon Monoxide Detectors

At the time of installation of the side wall horizontal vented gas fueled equipment, the installing plumber or gasfitter shall observe that a hard wired carbon monoxide detector with an alarm and battery back-up is installed on the floor level where the gas equipment is to be installed. In addition, the installing plumber or gasfitter shall observe that a battery operated or hard wired carbon monoxide detector with an alarm is installed on each additional level of the dwelling, building or structure served by the side wall horizontal vented gas fueled equipment. It shall be the responsibility of the property owner to secure the services of qualified licensed professionals for the installation of hard wired carbon monoxide detectors.

In the event that the side wall horizontally vented gas fueled equipment is installed in a crawl space or an attic, the hard wired carbon monoxide detector with alarm and battery back-up may be installed on the next adjacent floor level.

In the event that the requirements of this subdivision can not be met at the time of completion of installation, the owner shall have a period of thirty (30) days to comply with the above requirements; provided, however, that during said thirty (30) day period, a battery operated carbon monoxide detector with an alarm shall be installed.

Approved Carbon Monoxide Detectors

Each carbon monoxide detector as required in accordance with the above provisions shall comply with NFPA 720 and be ANSI/UL 2034 listed and IAS certified.

Signage

A metal or plastic identification plate shall be permanently mounted to the exterior of the building at a minimum height of eight (8) feet above grade directly in line with the exhaust vent terminal for the horizontally vented gas fueled heating appliance or equipment. The sign shall read, in print size no less than one-half (1/2) inch in size, "GAS VENT DIRECTLY BELOW. KEEP CLEAR OF ALL OBSTRUCTIONS".

Inspection

The state or local gas inspector of the side wall horizontally vented gas fueled equipment shall not approve the installation unless, upon inspection, the inspector observes carbon monoxide detectors and signage installed in accordance with the provisions of 248 CMR 5.08(2)(a)1 through 4.

Exemptions

The following equipment is exempt from 248 CMR 5.08(2)(a)1 through 4:

- The equipment listed in Chapter 10 entitled "Equipment Not Required To Be Vented" in the most current edition of NFPA 54 as adopted by the Board; and
- Product Approved side wall horizontally vented gas fueled equipment installed in a room or structure separate from the dwelling, building or structure used in whole or in part for residential purposes.

MANUFACTURER REQUIREMENTS**Gas Equipment Venting System Provided**

When the manufacturer of Product Approved side wall horizontally vented gas equipment provides a venting system design or venting system components with the equipment, the instructions provided by the manufacturer for installation of the equipment and the venting system shall include:

- Detailed instructions for the installation of the venting system design or the venting system components; and
- A complete parts list for the venting system design or venting system.

Gas Equipment Venting System NOT Provided

When the manufacturer of a Product Approved side wall horizontally vented gas fueled equipment does not provide the parts for venting the flue gases, but identifies "special venting systems", the following requirements shall be satisfied by the manufacturer:

- The referenced "special venting system" instructions shall be included with the appliance or equipment installation instructions; and
- The "special venting systems" shall be Product Approved by the Board, and the instructions for that system shall include a parts list and detailed installation instructions.

A copy of all installation instructions for all Product Approved side wall horizontally vented gas fueled equipment, all venting instructions, all parts lists for venting instructions, and/or all venting design instructions shall remain with the appliance or equipment at the completion of the installation.

See Gas Connection section for additional Commonwealth of Massachusetts requirements.

Top Vent or Rear Vent Configuration

This appliance is shipped in the top vent configuration. To change to the rear vent configuration, follow the directions below.

NOTE: the vent configuration affects several aspects of installation (framing, maximum vent rise, maximum vent run). Make sure the vent configuration is correct prior to installation. You may wish to configure the diffuser when changing the vent configuration.

NOTE: Use a magnetic-tipped nutdriver on these screws - take care to prevent the screws from falling into the fireplace.

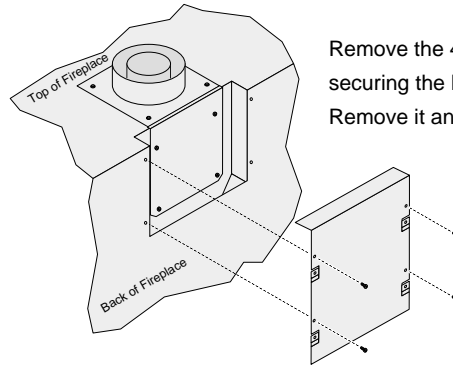
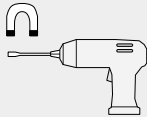

Remove the 4 screws securing the heat shield. Remove it and place it aside.

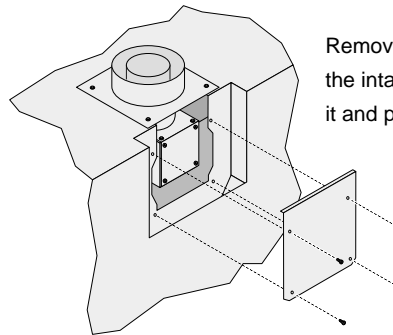

Remove the 4 screws securing the intake cover plate. Remove it and place it aside.

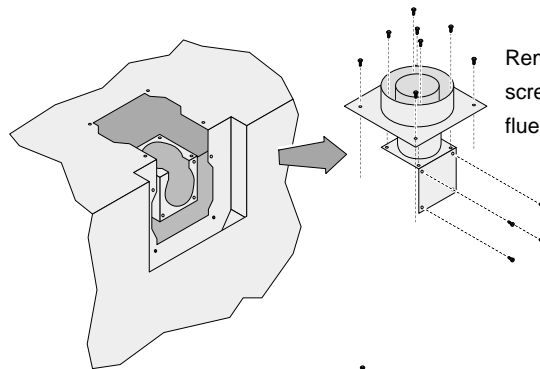

Remove the 12 screws securing the flue assembly.

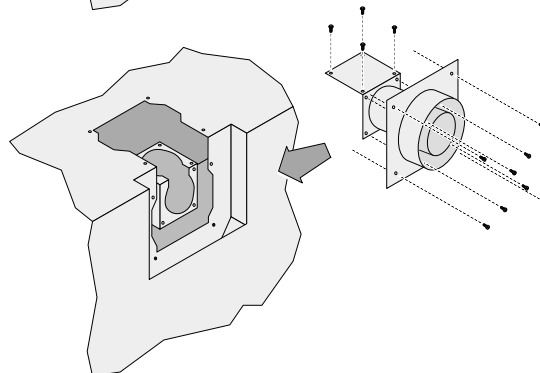

Rotate the flue assembly so the flue points to the rear. Secure using the twelve screws removed earlier.

DO NOT OVER-TIGHTEN THE SCREWS.

Converting the Fireplace to Rear Vent (continued)

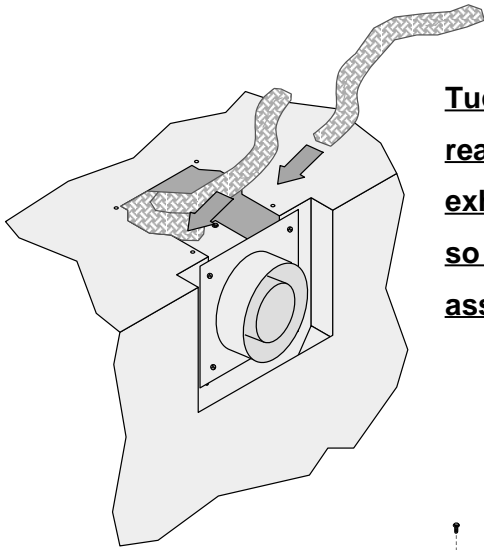

Tuck the 3 pieces of insulation (included in the rear vent conversion kit) into the area above the exhaust manifold. The insulation must be placed so it covers the entire area over the flue assembly.

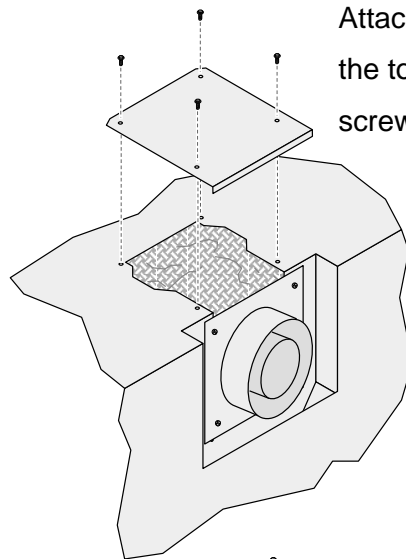

Attach the intake cover plate to the top of the fireplace using the screws removed earlier.

Bend the heat shield legs downward as shown.

Remove the screws from the top of the fireplace. Attach the heat shield to the top of the fireplace using these screws.

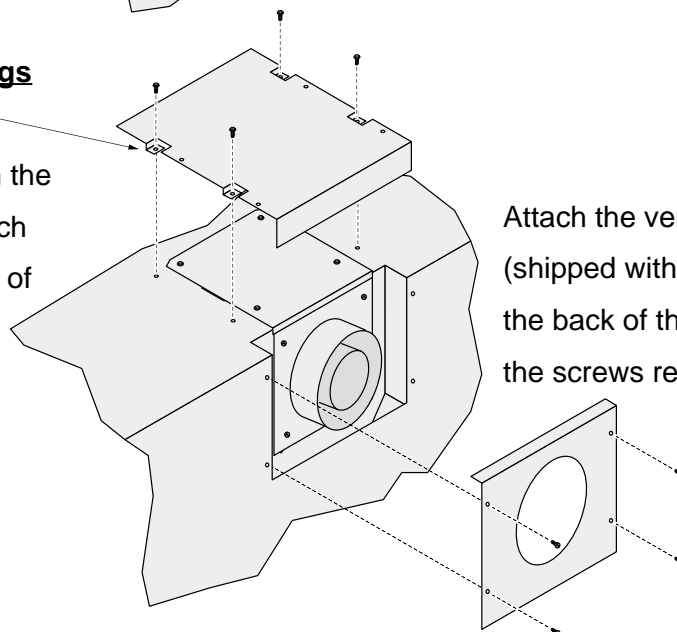

Attach the vent cover plate (shipped with the fireplace) to the back of the fireplace using the screws removed earlier.

Fireplace Placement Requirements

- Fireplace must be installed on a level surface capable of supporting the fireplace and vent
- Fireplace must be placed directly on wood or non-combustible surface (not on linoleum or carpet)
- This heater may be placed in a bedroom. Please be aware of the large amount of heat this appliance produces when determining a location.

Clearances

- The fireplace requires a 1/2" (13mm) clearance from the angled sides and back of the fireplace to the framing members. No material (insulation, framing, etc.) may be placed into this area.
- When installed, walls in front of the fireplace must be a minimum 1" (25mm) to the side of the fireplace.
- Due to the high temperature, the heater should be located out of traffic and away from furniture and draperies.
- Fireplace must be placed so the vents below and above the glass do not become blocked.

Raised Fireplaces

- The fireplace (and hearth, if desired) may be placed on a platform designed to support the fireplace (205 Lbs. 93 Kg) and vent.
- The base of the fireplace must be a minimum 70" (1778mm) below the room ceiling.

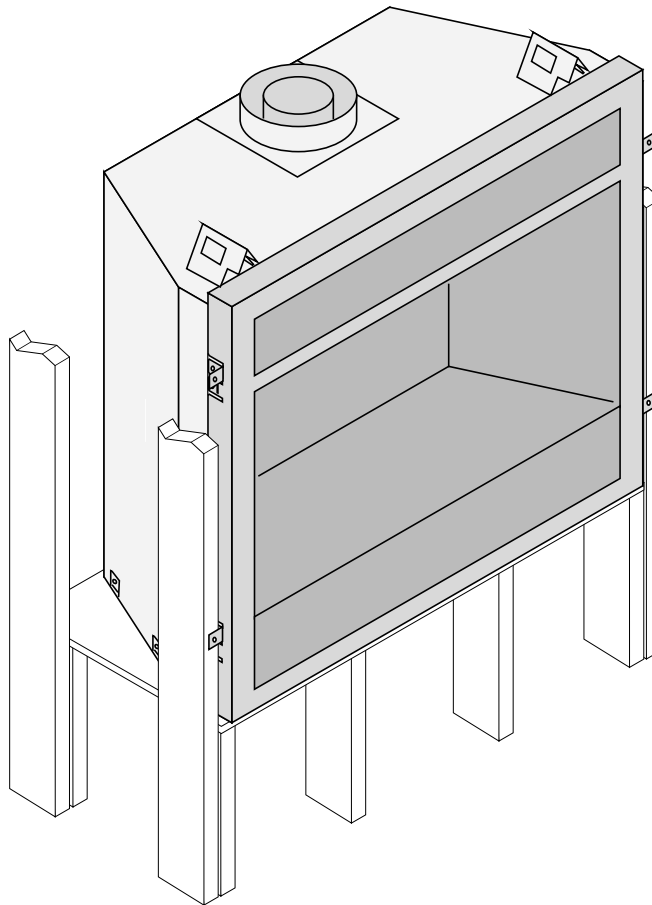

Televisions Placed Above the Fireplace

The following section details three methods to allow for television installation above the fireplace.

Using a Mantel Between the Fireplace and Television

IMPORTANT NOTE REGARDING TELEVISIONS AND THIS FIREPLACE

Most television manufacturers instruct the homeowner to not place the television above a heat source. Doing so may negatively affect the longevity of the television and may negate the warranty. If you do place a television above the fireplace, please be aware of the large amount of heat generated by the fireplace and consider placing the television above a mantel to reduce the amount of heat that reaches the television. The homeowner must understand that Travis Industries does not take responsibility for any negative impact to televisions placed near this fireplace.

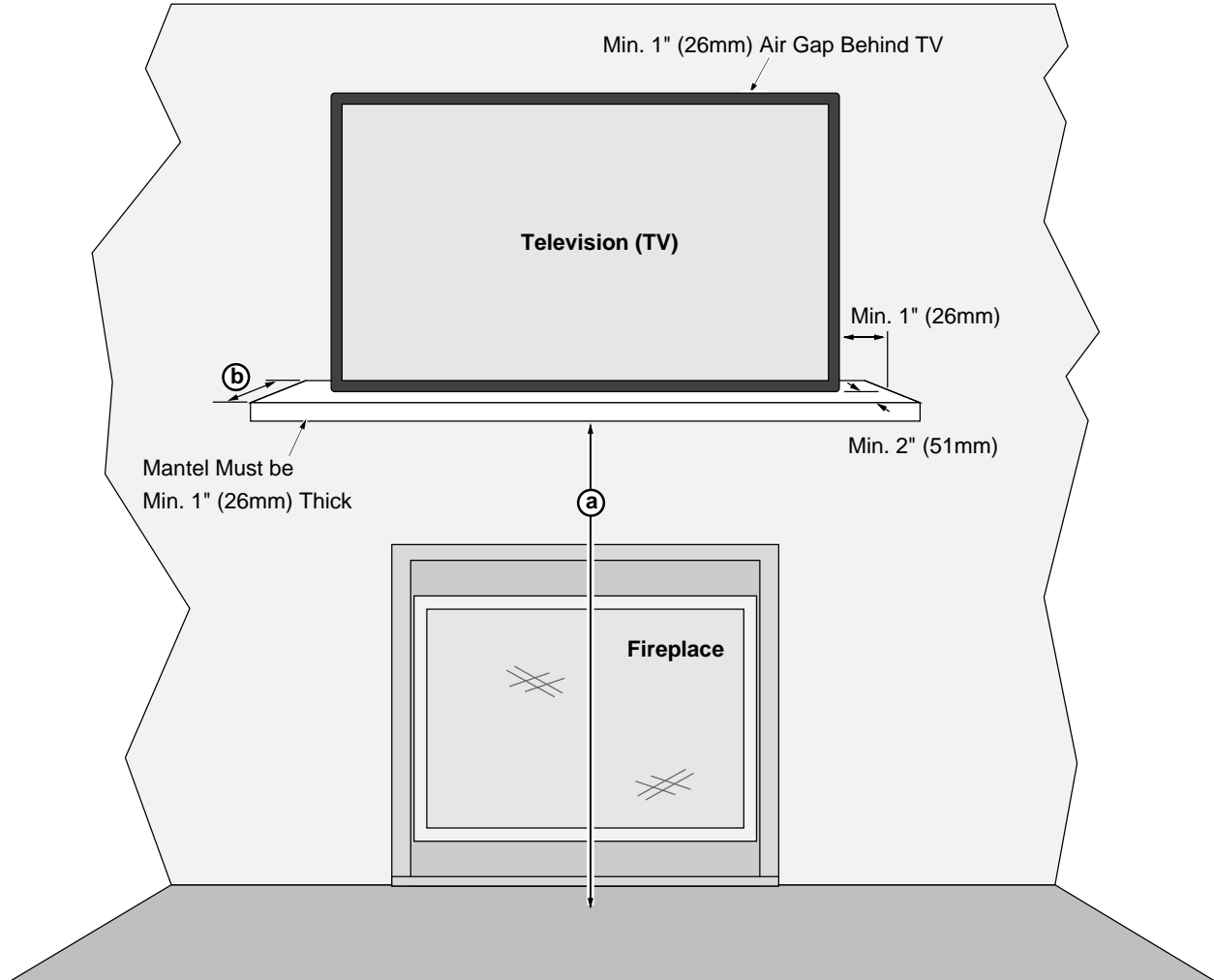

Minimum Dimensions:

(a) Minimum Mantel Height above Base of Fireplace*	44.75" (1137mm) with 8" (203mm) mantel depth
(b) Mantel Depth*	Minimum 8" (203mm)*

*** Mantel depth is 8" minimum to allow heat to travel forward and dissipate. If using more than an 8" mantel, make sure to make the mantel height (a) higher (see mantel requirements on page 44 for details).**

NOTE: The mantel must extend 2" in front of the TV and 1" to both sides. If you have a TV that is greater than 6" deep (including the 1" gap behind), you will need to alter the mantel depth and height.

WIRING NOTE: If running wiring into the enclosure, use thermal insulating wrap around the wiring. Secure the wiring to protect from contact with hot surfaces.

Using a Buildout Above Fireplace and Television

IMPORTANT NOTE REGARDING TELEVISIONS AND THIS FIREPLACE

Most television manufacturers instruct the homeowner to not place the television above a heat source. Doing so may negatively affect the longevity of the television and may negate the warranty. If you do place a television above the fireplace, please be aware of the large amount of heat generated by the fireplace and consider placing the television above a mantel to reduce the amount of heat that reaches the television. The homeowner must understand that Travis Industries does not take responsibility for any negative impact to televisions placed near this fireplace.

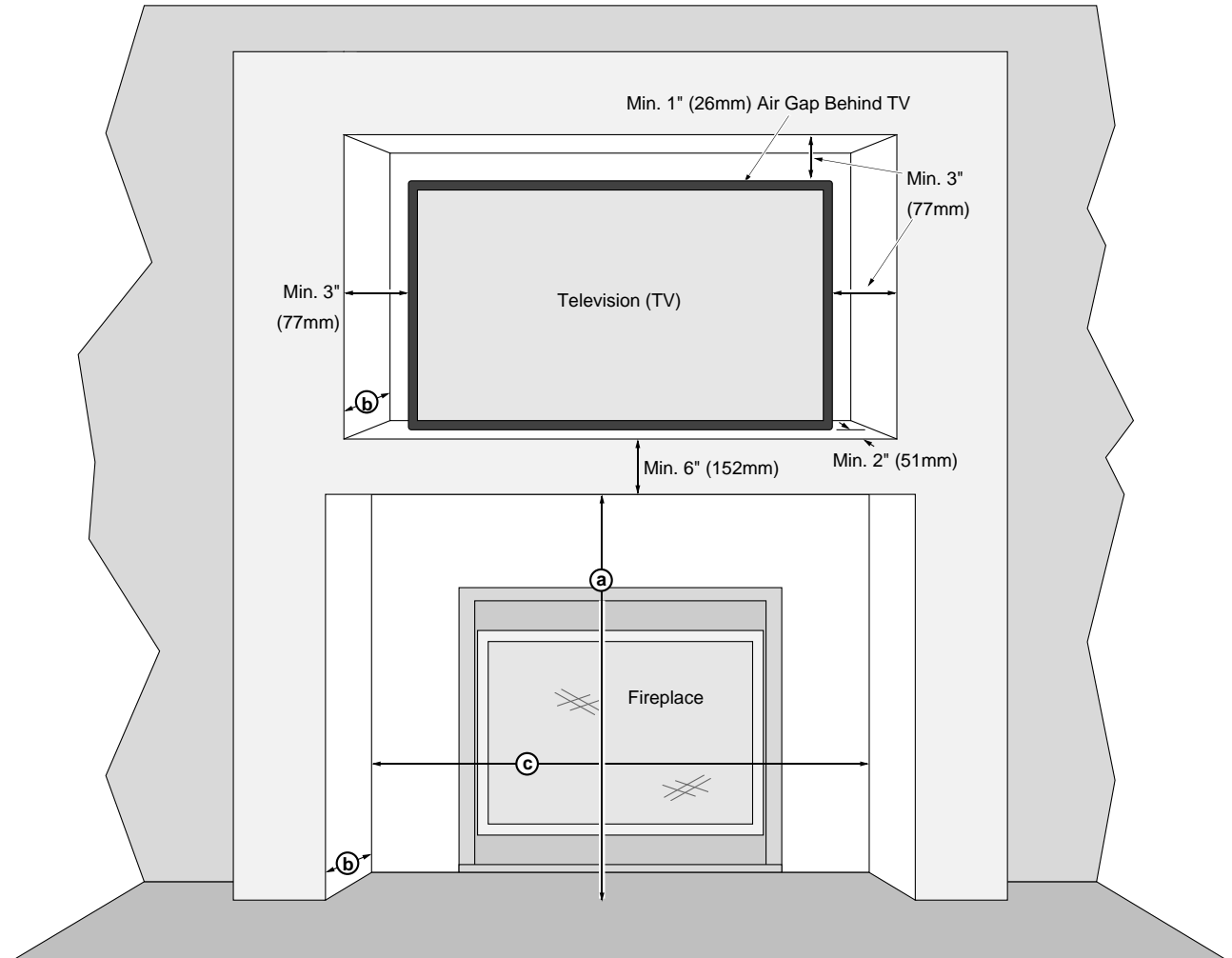

Minimum Dimensions:

(a) Minimum Buildout Height above Base of Fireplace*	44.75" (1137mm) with 8" (203mm) buildout depth
(b) Minimum Fireplace/TV Buildout Depth*	Minimum 8" (203mm)*
(c) Fireplace Buildout Width	43" (1093mm)

*** Buildout depth is 8" minimum to allow heat to travel forward and dissipate. If using more than an 8" buildout, make sure to make the buildout height (a) higher (buildout must meet mantel requirements - see page 44 for details).**

NOTE: The buildout must extend 2" in front of the TV and 3" to both sides and top. If you have a TV that is greater than 6" deep (including the 1" gap behind), you will need to alter the buildout depth and height.

WIRING NOTE: If running wiring into the enclosure, use thermal insulating wrap around the wiring. Secure the wiring to protect from contact with hot surfaces.

Using a Buildout Below a Television

IMPORTANT NOTE REGARDING TELEVISIONS AND THIS FIREPLACE

Most television manufacturers instruct the homeowner to not place the television above a heat source. Doing so may negatively affect the longevity of the television and may negate the warranty. If you do place a television above the fireplace, please be aware of the large amount of heat generated by the fireplace and consider placing the television above a mantel to reduce the amount of heat that reaches the television. The homeowner must understand that Travis Industries does not take responsibility for any negative impact to televisions placed near this fireplace.

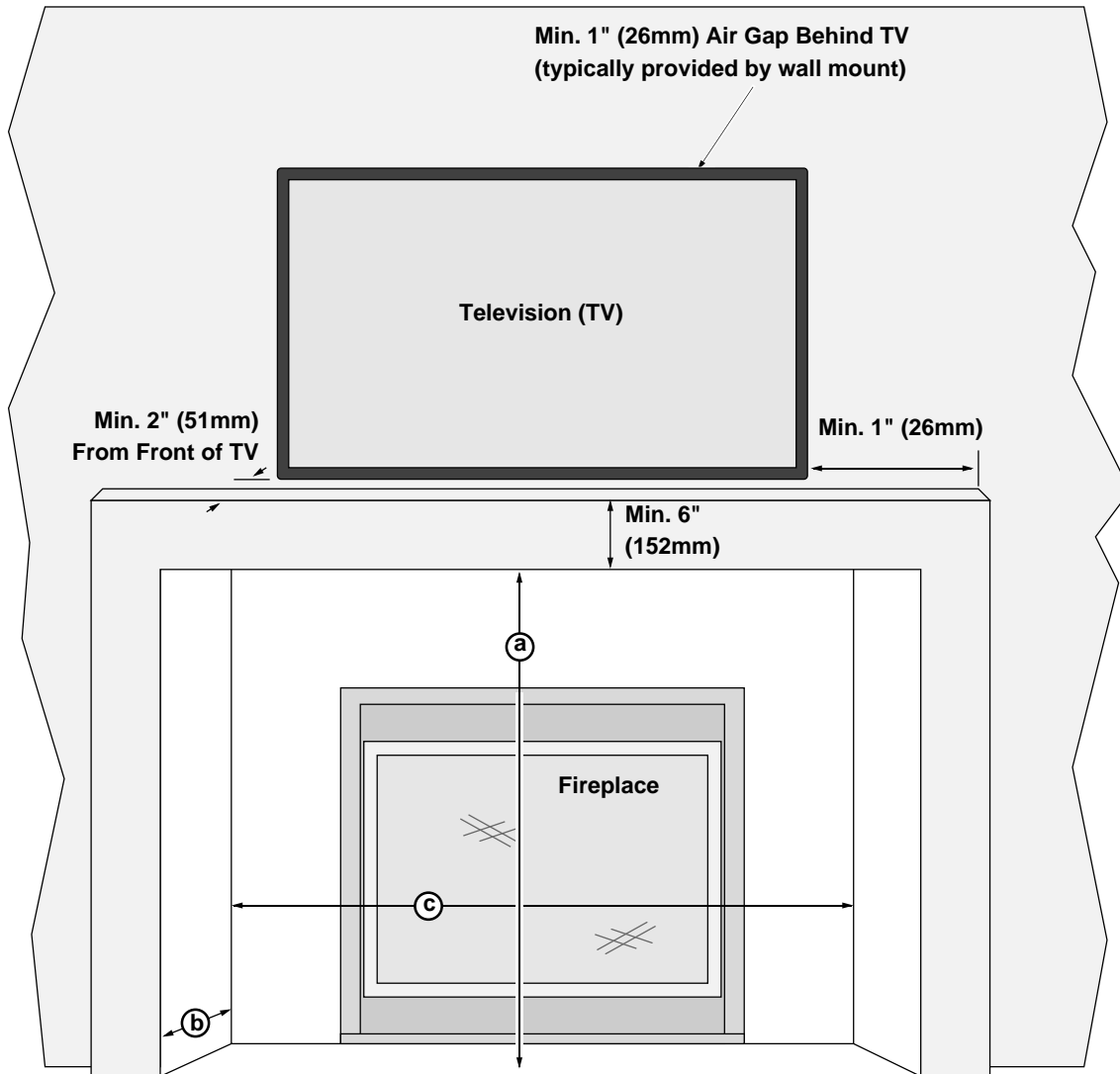

Minimum Dimensions:

(a) Minimum Buildout Height above Base of Fireplace*	44.75" (1137mm) with 8" (203mm) buildout depth
(b) Minimum Buildout Depth*	Minimum 8" (203mm)*
(c) Fireplace Buildout Width	43" (1093mm)

*** Buildout depth is 8" minimum to allow heat to travel forward and dissipate. If using more than an 8" buildout, make sure to make the buildout height (a) higher (buildout must meet mantel requirements - see page 44 for details).**

NOTE: The buildout must extend 2" in front of the TV and 3" to both sides and top. If you have a TV that is greater than 6" deep (including the 1" gap behind), you will need to alter the buildout depth and height.

WIRING NOTE: If running wiring into the enclosure, use thermal insulating wrap around the wiring. Secure the wiring to protect from contact with hot surfaces.

Minimum Framing Dimensions - Rear Vent Configuration

HINT: place the fireplace so the center line is at least 5" (127mm) from both vertical framing members at the rear (this allows the vent to pass through the framing without modifications)

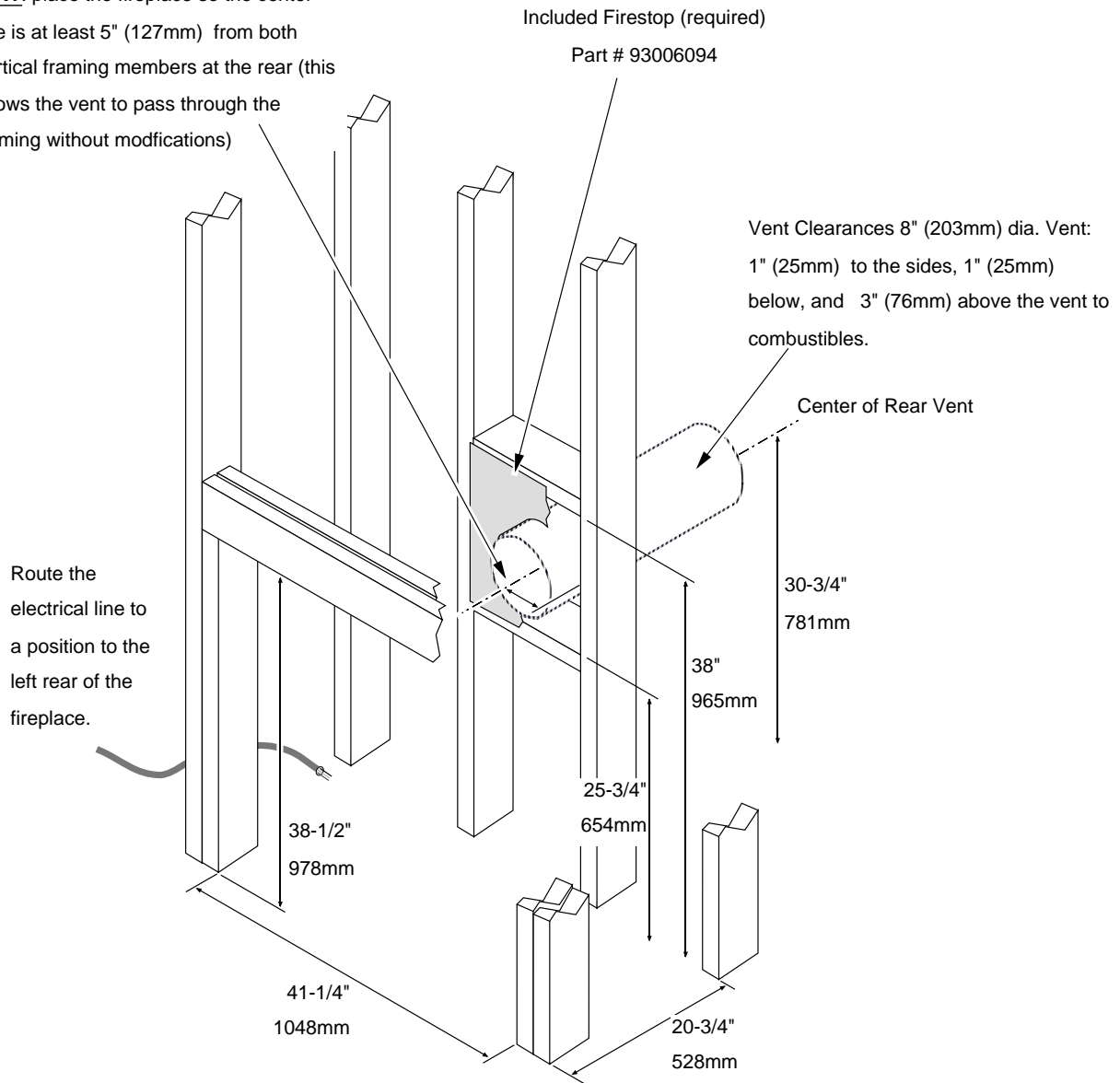

Minimum enclosure height = 38-1/2" (978mm)

Minimum Framing Dimensions - Top Vent Configuration

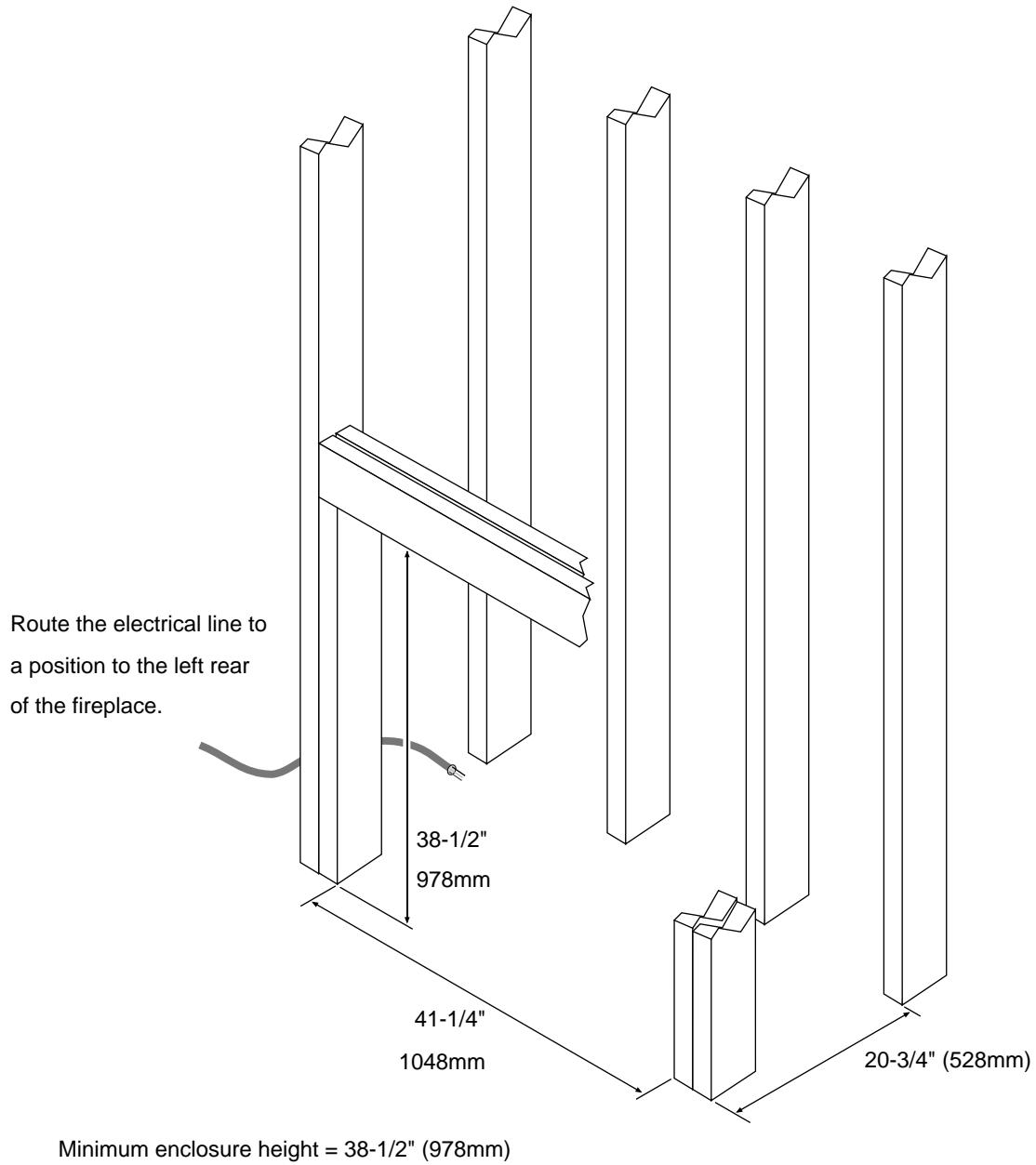

Nailing Brackets

The fireplace has nailing brackets on both sides. Secure the fireplace to the framing.

NOTE: Make sure the fireplace is square and plumb when placed in the framing. Measured corner-to-corner the fireplace should be square (approx. 54-7/8" – 1394mm). See the illustration below. Use shims to insure the fireplace is square.

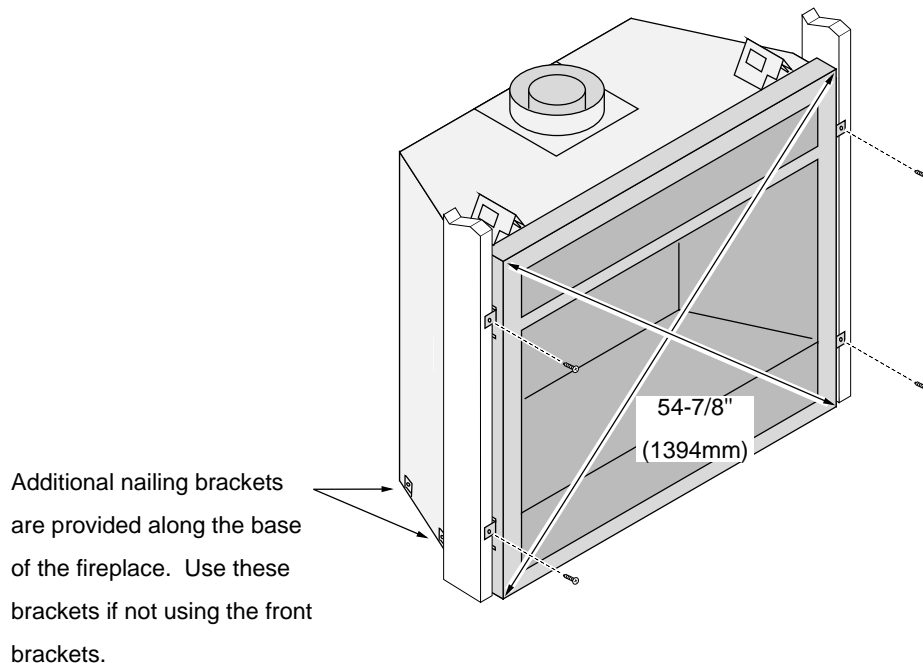

1/2" (13mm)

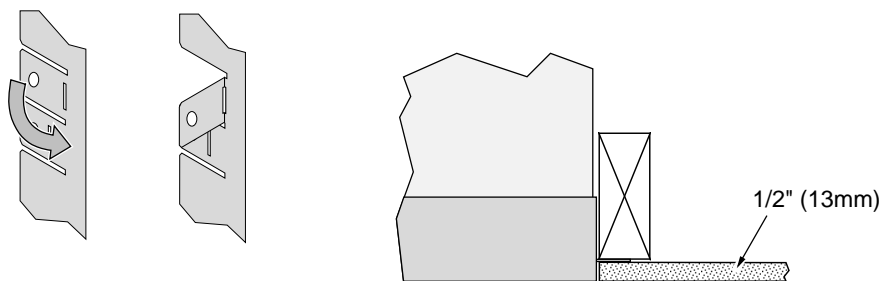

5/8" (16mm)

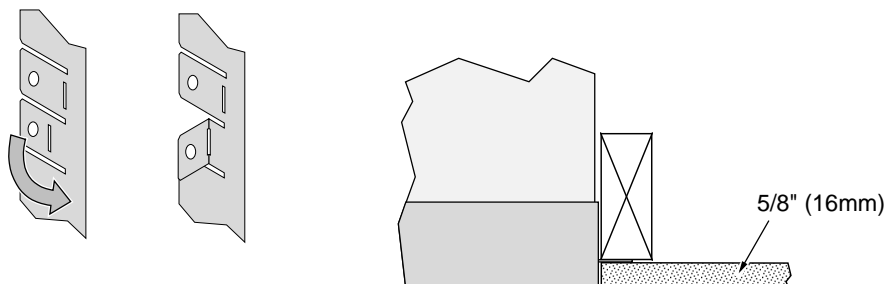

Corner Installations - Rear Vent Configuration

A typical 45° installation uses the framing dimensions shown in the illustration below (NOTE: all clearances still apply).

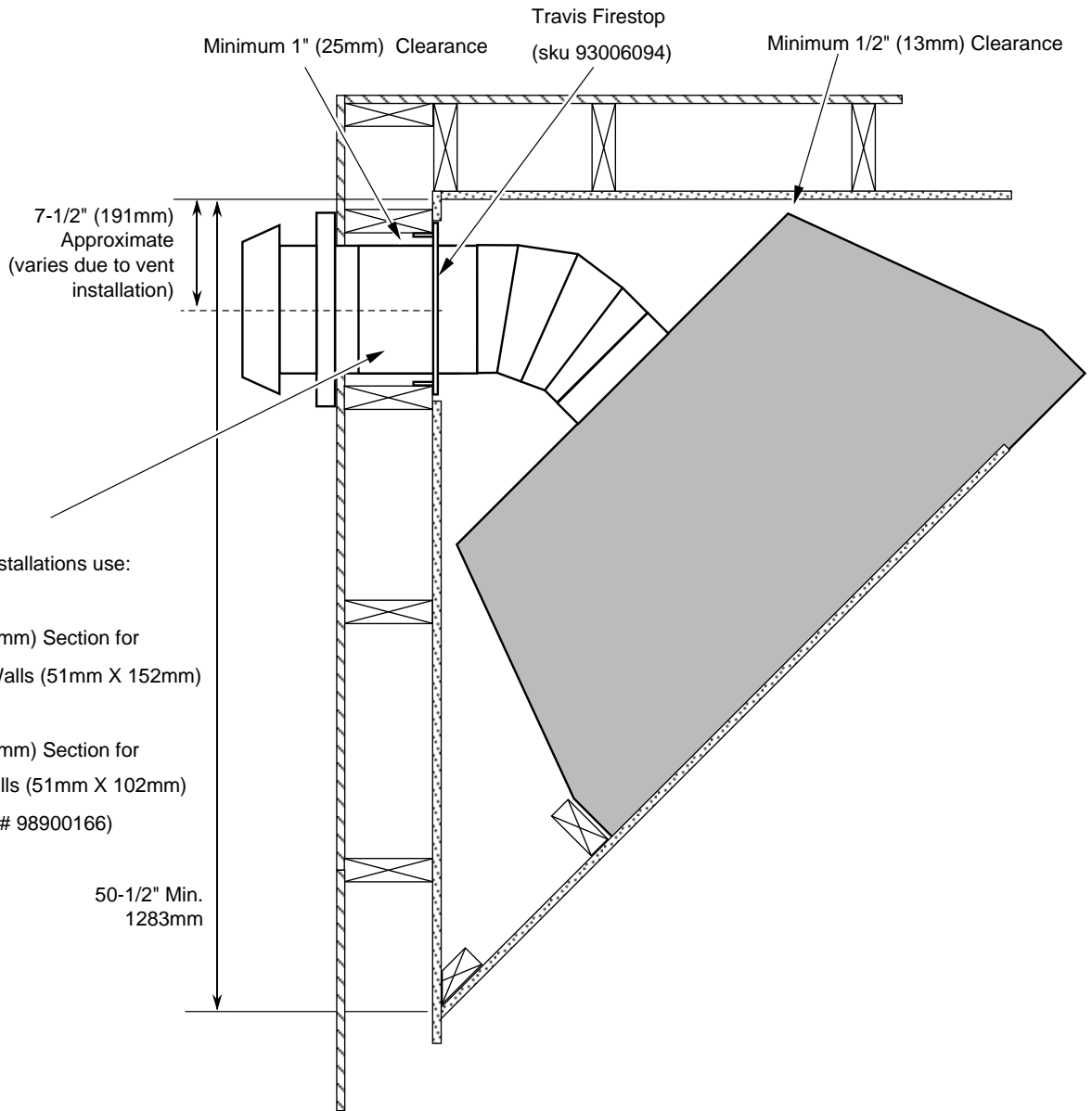

Corner Installations - Top Vent Configuration

A typical 45° installation uses the framing dimensions shown in the illustration below (NOTE: all clearances still apply).

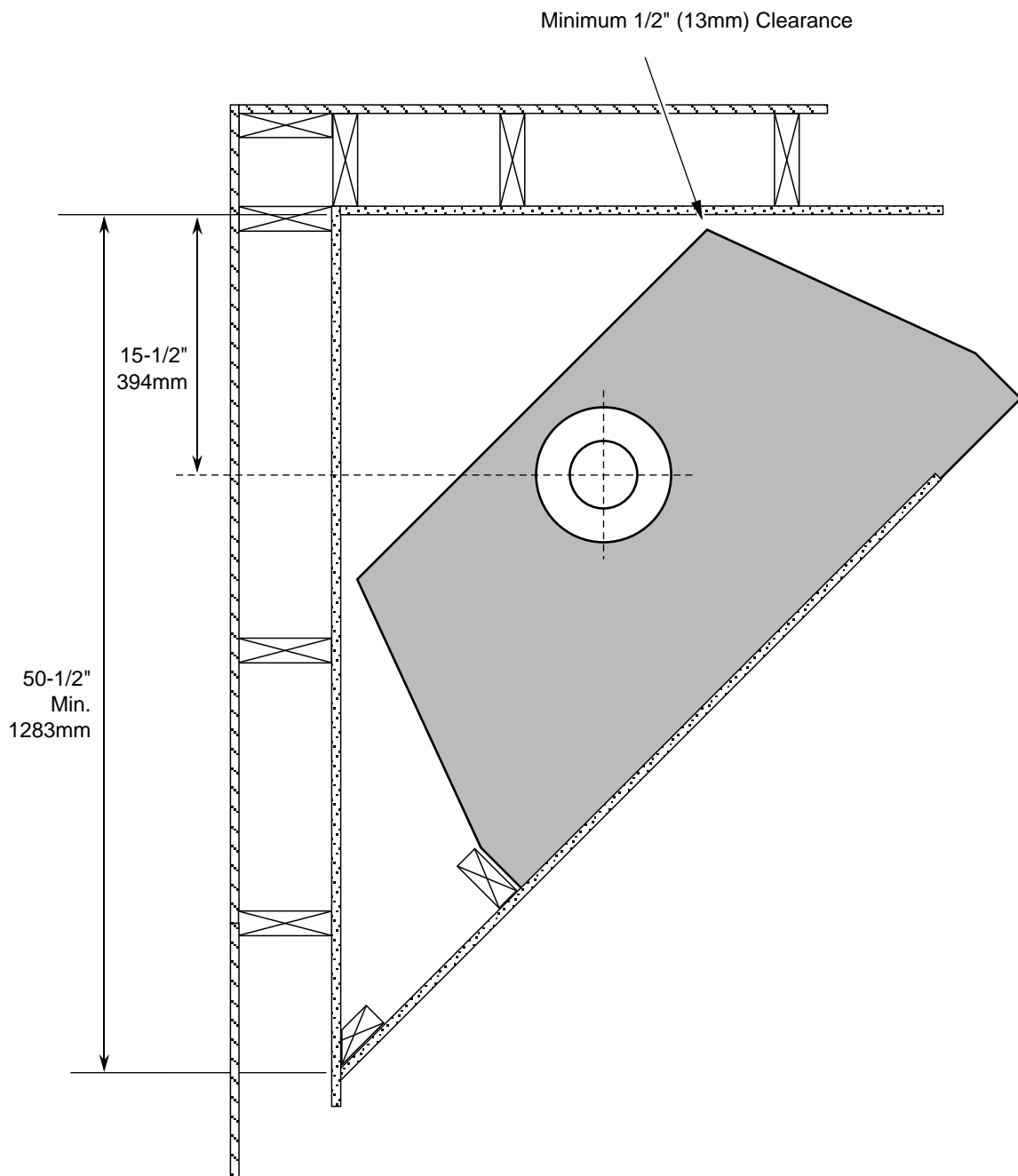

Outdoor Fireplace Installations

Travis Industries Inc. gas-fired fireplaces are suitable for installation into outdoor areas protected from direct water impingement. In addition to maintaining listed mantel and combustibles clearances, a rain protection overhang factor of 1/2 shall be constructed to the front and to each side of installed appliances (see the illustration to the right). All wiring connections to line power shall be in accordance with outdoor requirements of NECA NFPA 70.

Warnings Regarding Tempered Glass

This fireplace uses tempered glass which is susceptible to thermal shock. Take care to prevent water from contacting the fireplace, especially if it is hot.

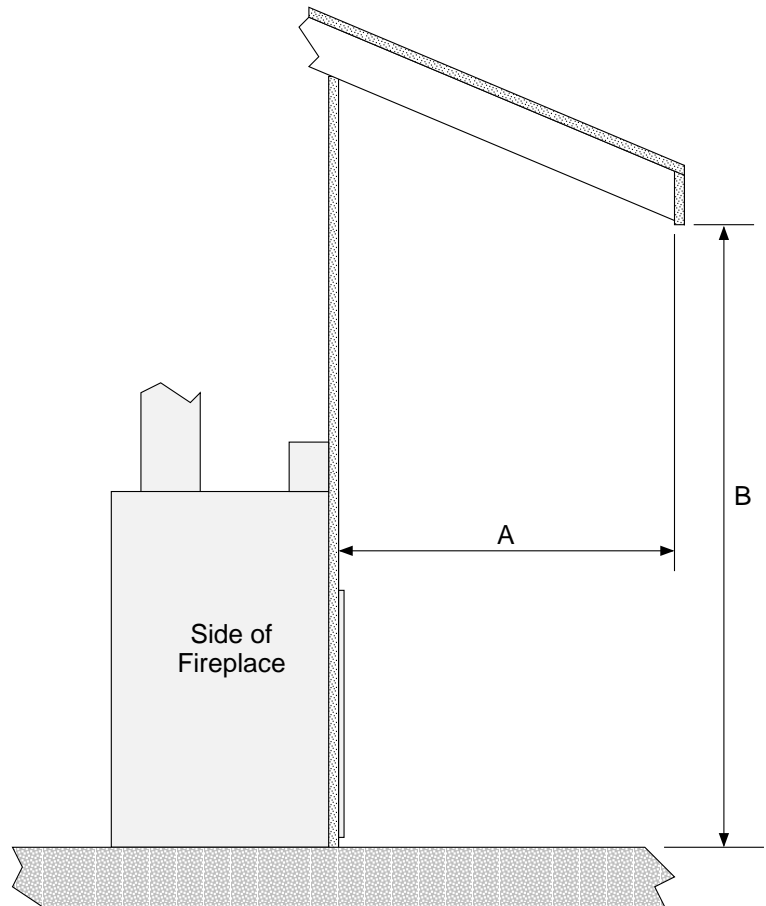

The overhang (A) must extend at least 1/2 the roofline height (B). Height is measured from the base of the fireplace.

For example: if the roofline (B) is 8' above the base of the fireplace, the overhang (A) must be at least 4'.

Gas Line Requirements

MASSACHUSETTS INSTALLATIONS - **WARNING:**

THIS PRODUCT MUST BE INSTALLED BY A LICENSED PLUMBER OR GAS FITTER WHEN INSTALLED WITHIN THE COMMONWEALTH OF MASSACHUSETTS.

OTHER MASSACHUSETTS CODE REQUIREMENTS:

- Flexible connector must not be longer than 36 inches.
- Shutoff valve must be a "T" handle gas cock.
- Only direct vent sealed combustion products are approved for bedrooms or bathrooms.
- Fireplace dampers must be removed or welded in the open position prior to the installation of a fireplace insert or gas log.
- A carbon monoxide (CO) detector is required in the same room as the appliance.
- The gas line must be installed in accordance with all local codes, if any; if not, follow ANSI 223.1 and NFPA 54(88), in Canada follow CSA B149.1 and the requirements listed below.
- The fireplace and gas control valve must be disconnected from the gas supply piping during any pressure testing of that system at test pressures in excess of 1/2 psig (3.5 kPA). For pressures under 1/2 psig (kPA), isolate the gas supply piping by closing the manual shutoff valve.
- Leak test all gas line joints and the gas control valve prior to and after starting the fireplace.

Fuel

- This fireplace is designed either for natural gas or for propane (but not for both). Check the sticker on the top of the gas control valve to make sure the correct fuel is used.

Gas Line Connection

- Installation must be performed by a qualified installer, service agency or the gas supplier (In Massachusetts a licensed plumber/gasfitter).

Gas Inlet Pressure

Gas Pressure	Max. Input Pressure	Min. Input Pressure	Max. Manifold Pressure	Min. Manifold Pressure
Natural Gas	7" W.C. (1.74 kPA)	5.5" W.C. (1.37 kPA)	3.5" W.C. (0.87 kPA)	1.6" W.C. (0.40 kPA)
Propane	13" W.C. (3.23 kPA)	11" W.C. (2.74 kPA)	11" W.C. (2.74 kPA)	2.9" W.C. (0.72 kPA)

- If the pressure is not sufficient, make sure the piping used is large enough, the supply regulator is adequately adjusted, and the total gas load for the residence does not exceed the amount supplied.
- The supply regulator (the regulator that attaches directly to the residence inlet or to the propane tank) should supply gas at the suggested input pressure listed above. Contact the local gas supplier if the regulator is at an improper pressure.

Directions for Connecting a Gas Pressure Test Gauge

The gas control valve (shown to the right) has two test ports for testing input (line pressure) and output (manifold) pressure. Loosen the brass screw on either test port and place a 5/16" i.d. rubber or plastic tube over the tapered test port. Connect the tube to the test gauge.

WARNING: The brass screw must be tightened after testing to prevent gas leakage.

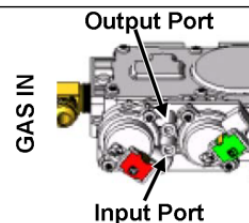

Gas Line Location

NOTE FOR RIGID PIPE: When using rigid pipe, you may wish to disconnect the shutoff valve from the fireplace and route the pipe through the fireplace wall. First, disconnect the gas line from the shutoff valve (see step 1 below). Then remove the shutoff valve from the cover plate (4 screws outside fireplace). The pipe may be routed through the cover plate and the shutoff valve and gas line may be re-attached inside the fireplace.

Right Side Gas Line (Stock)

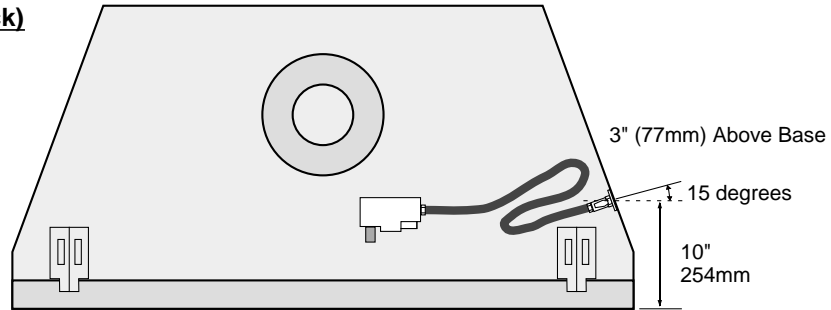

Left Side Gas Line

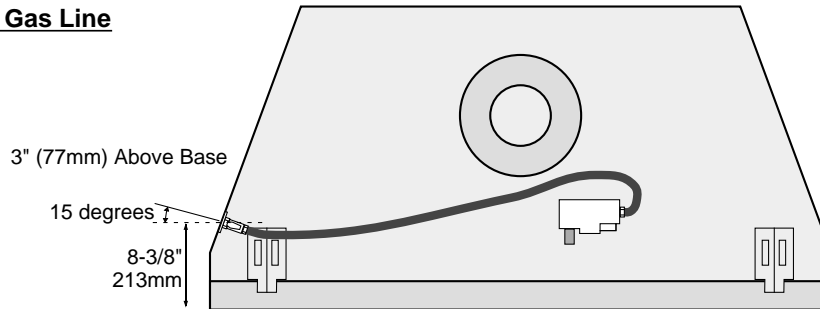

Converting Gas Line to the Left Side

1. Disconnect the gas line from the shutoff valve (3/4" wrench). Gas line is located inside the fireplace on the right side.

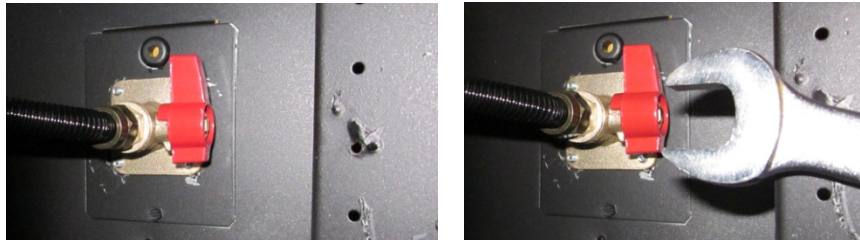

2. Remove the screw that holds the shutoff valve plate in place (1/4" nutdriver). Remove the shutoff valve plate.

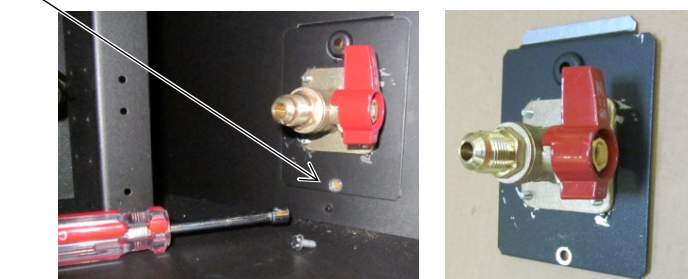

3. Remove the cover plate from the left side of the fireplace (it is held in place in the same fashion as the shutoff valve plate). Attach it to the right side of the fireplace.
4. Attach the shutoff valve plate to the left side of the fireplace. Route the gas line to the left side and re-attach the gas line to the shutoff valve. Make sure to leak test the entire gas line.

Electrical Connection (required)

- The electrical line to the grounded receptacle inside the fireplace must be installed by a qualified installer and must meet all local codes.
- Make sure the household breaker is shut off prior to working on any electrical lines.
- The appliance, when installed, must be electrically grounded in accordance with local codes or, in the absence of local codes, with the National Electrical Code, ANSI/NFPA 70, or the Canadian Electrical Code, CSA C22.1.
- The electrical line must be a min. 14 gauge, and supply 120 Volts at 60 Hz (2 Amps).

Caution: Label all wires prior to disconnection when servicing controls. Wiring errors can cause improper and dangerous operation.

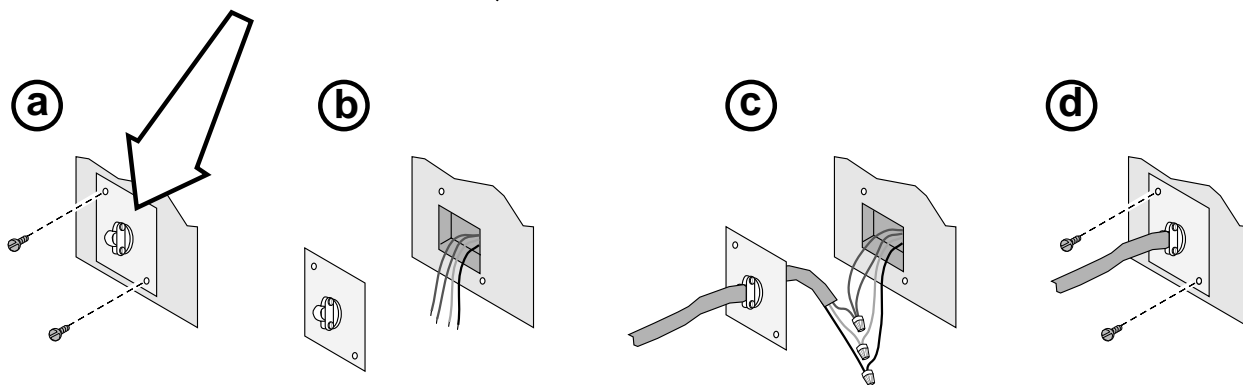
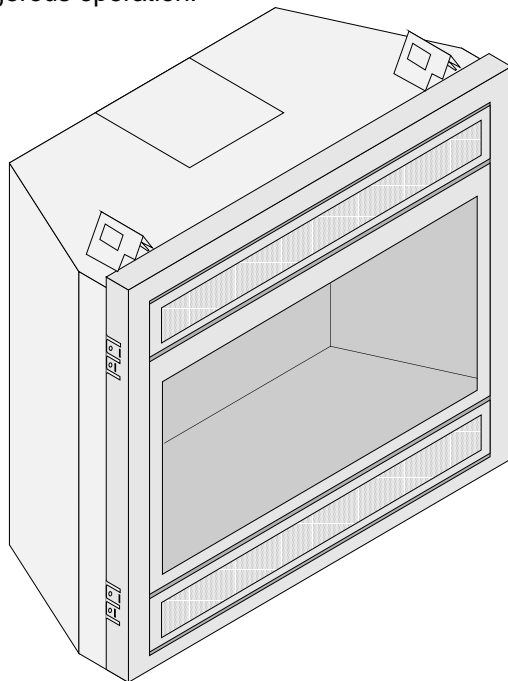

Optional Wall Switch or Thermostat Installation



Do not connect 110-120 VAC to the gas control valve or wiring system of this fireplace. The switch and wiring must be installed by a qualified installer.

This fireplace includes an optional wall switch (with wire) to operate the fireplace burner without accessing the internal on/off switch. A thermostat may be used instead.

Route the wire from inside the fireplace, through the grommet on either side of the fireplace near the gas inlet (see at right) to the switch. The wall switch (or thermostat) may bypass the fireplace on/off switch or be installed in parallel or series configuration (see below).

Caution: Label all wires prior to disconnection when servicing controls. Wiring errors can cause improper and dangerous operation.

Note: When using a GreenSmart™ remote, use the receiver for on/off operation (do not use a wall switch or thermostat).

Warning: Make sure all wiring is secure and does not contact hot or moving components.

OPTIONAL WALL SWITCH
(included with fireplace)

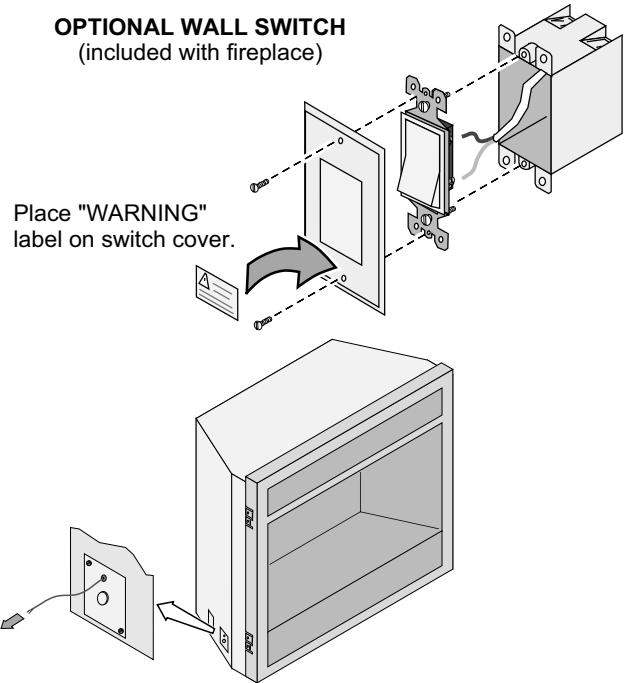

Parallel Connection

	On / Off Switch ON	On / Off Switch OFF
Thermostat / External Switch ON	Heater is ON	Heater is ON
Thermostat / External Switch OFF	Heater is ON	Heater is OFF

To wire the heater in parallel, follow the directions below:

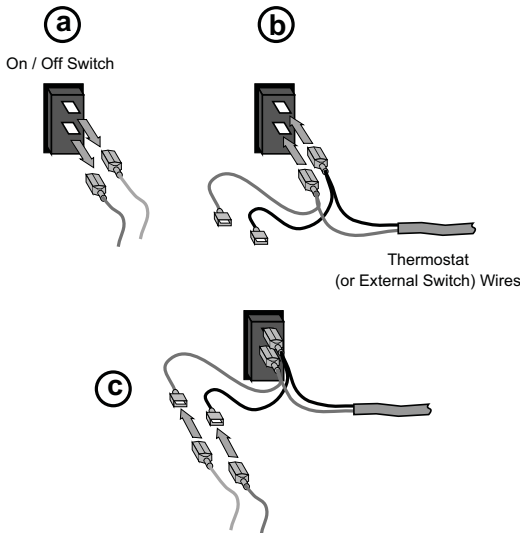

Series Connection

	On / Off Switch ON	On / Off Switch OFF
Thermostat / External Switch ON	Heater is ON	Heater is OFF
Thermostat / External Switch OFF	Heater is OFF	Heater is OFF

To wire the heater in series, follow the directions below:

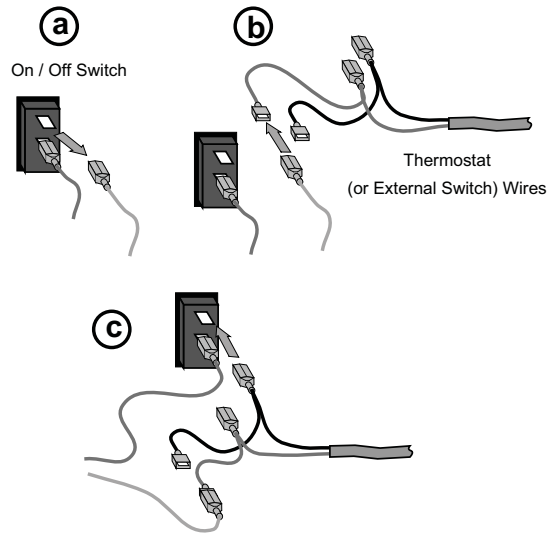

Vent Requirements

- The gas appliance and vent system must be vented directly to the outside of the building, and never be attached to a chimney serving a separate solid fuel or gas-burning appliance. Each direct vent gas appliance must use its own separate vent system.
- In addition to the requirements listed here, follow the requirements provided with the vent.
- A firestop is required whenever the vent penetrates a wall, floor, or ceiling (passes through framing members). Horizontal vent less than 48" (1219mm) above the fireplace must use the Travis Firestop (sku 93006094 - it incorporates a 3" (76mm) clearance above, 1" (25mm) clearance below and to the sides of the vent). Other penetrations only require a 1" (25mm) clearance and may use a standard firestop (make sure the required 1" (25mm) clearance is met).

Drafting Performance

This direct vent appliance requires natural draft to operate (similar to a wood stove or other heating appliance). Draft can be adjusted using the included restrictor. The restrictor settings detailed in the manual should be followed (variations may occur depending upon installation parameters).

Many factors may negatively influence the draft of the appliance. Travis Industries will not be responsible for improper draft due to factors such as trees, hills, buildings, obstructions, excessive wind, extreme hot or cold outdoor temperatures, restrictive vent terminations, or influence from mechanical systems.

Vent Clearances

- The vent must maintain the required clearance to combustibles to prevent a fire. Do not fill air spaces with insulation.

	Before 48" (1219mm) Rise	After 48" (1219mm) Rise
Sides	1" (25mm)	1" (25mm)
Above	3" (76mm)	1" (25mm)
Below Horizontal or 45° Section	1" (25mm)	1" (25mm)

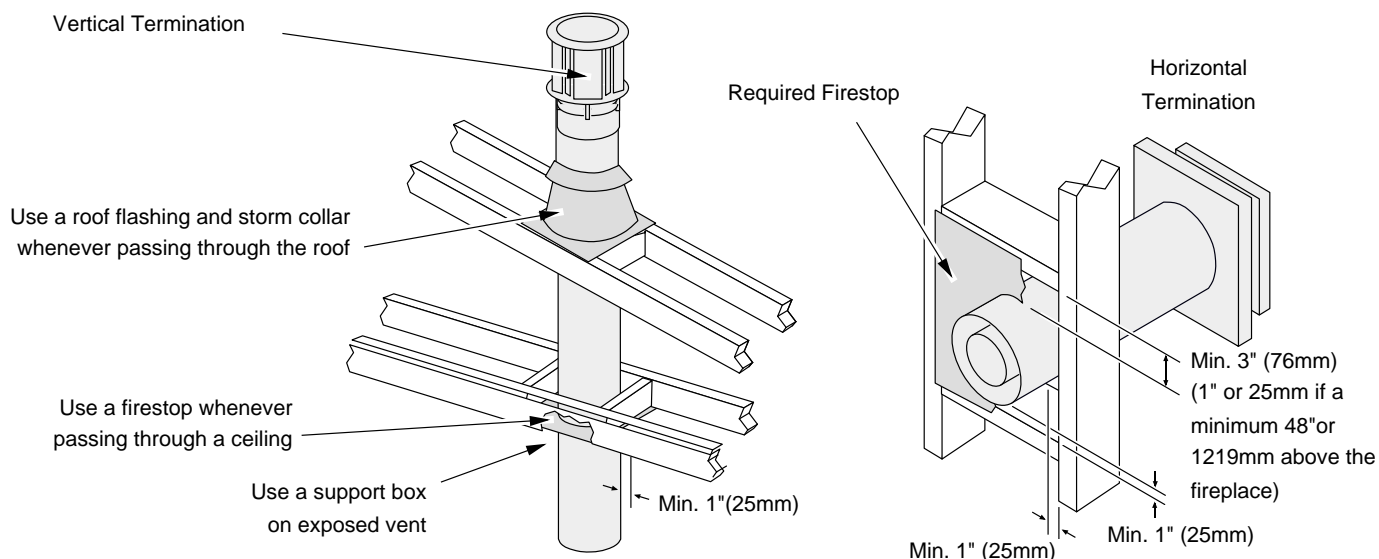

Altitude Considerations

- This heater has been tested at altitudes ranging from sea level to 6,000 feet (1800 M). In this testing we have found that the heater, with its standard orifice, burns correctly with just an air shutter adjustment.
- Failure to adjust the air shutter properly may lead to improper combustion which can create a safety hazard. Consult your dealer or installer if you suspect an improperly adjusted air shutter.

Approved Vent

- Rear vent configurations use 8" (203mm) diameter Simpson Dura-Vent Model Direct-Vent Pro (or GS)*.
- Top vent configurations use 8" (203mm) or 6-5/8" (168mm) diameter Simpson Dura-Vent Direct-Vent Pro (or GS)*. If using 6-5/8" (168mm) diameter vent, attach the 8" (203mm) to 6-5/8" (168mm) reducer (Travis part # 98900165) to the fireplace.

NOTE: When using 6-5/8" (168mm) diameter vent, make sure to accommodate the 3" (76mm) clearance above the vent for the first 48" (1219mm) of rise (see vent clearances on page 25). Standard firestops do not include this clearance.

* Other vent may be approved with this fireplace. Check with the vent manufacturer for details.

- Always use the high-wind cap (or high-wind sconce cap, part # 58DVA-HSCH or 46DVA-HSCH).
- Installation instructions for Simpson Dura-Vent may be found at www.duravent.com

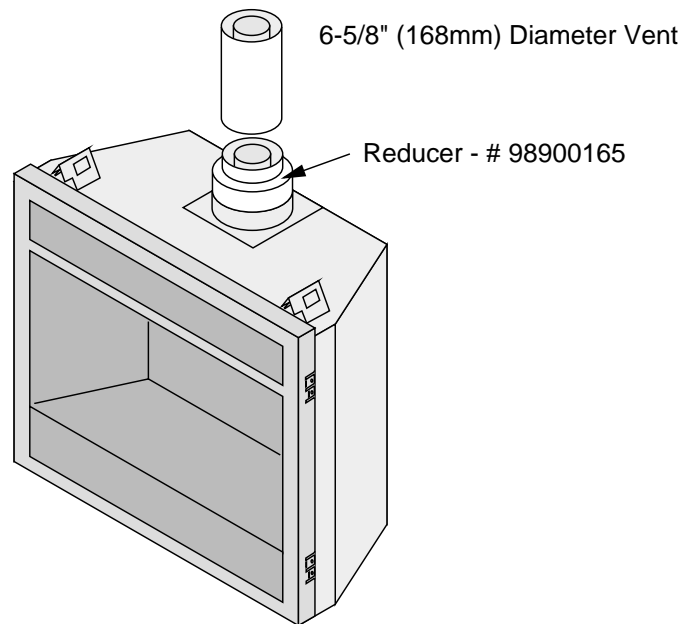

Vent Installation

- Slide the vent sections together and turn 1/4 turn until the sections lock in place.
- Screws are not required to secure the vent. However, three screws may be used to secure vent sections together if desired.
- High temperature sealant is recommended at the appliance starter section connection (use high-temperature silicone or Mill-Pac®).
- If disassembly is required, at time of re-assembly check to see if the vent creates a tight fit. If it does not, apply high temperature sealant to the joints of the affected sections.
- Horizontal sections require a 1/4" (6mm) rise every 12" (305mm) of travel
- Horizontal sections require non-combustible support every three feet (e.g.: plumbing tape)

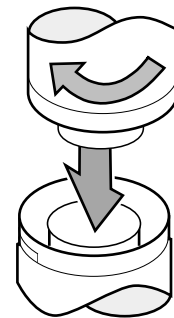

Approved Vent Configurations

Restrictor Position

- Intake and exhaust restrictors are built into the appliance to adjust the flow rate of intake air and exhaust gases. Depending upon the vent configuration, you may be required to adjust the restrictor positions. The charts for acceptable vent configurations detail the correct vent restrictor positions.

Exhaust Restrictor Adjustment



If the diffuser is required to be in position # 2, you may wish to adjust the diffuser while the exhaust restrictor is removed.

NOTE: The restrictor is held in place with 4 screws. If using position 4, 5, or 6, remove the forward screws. These screws may be replaced in the holes if using position 5 or 6. For position 4 the screws holes are covered by the restrictor plate.

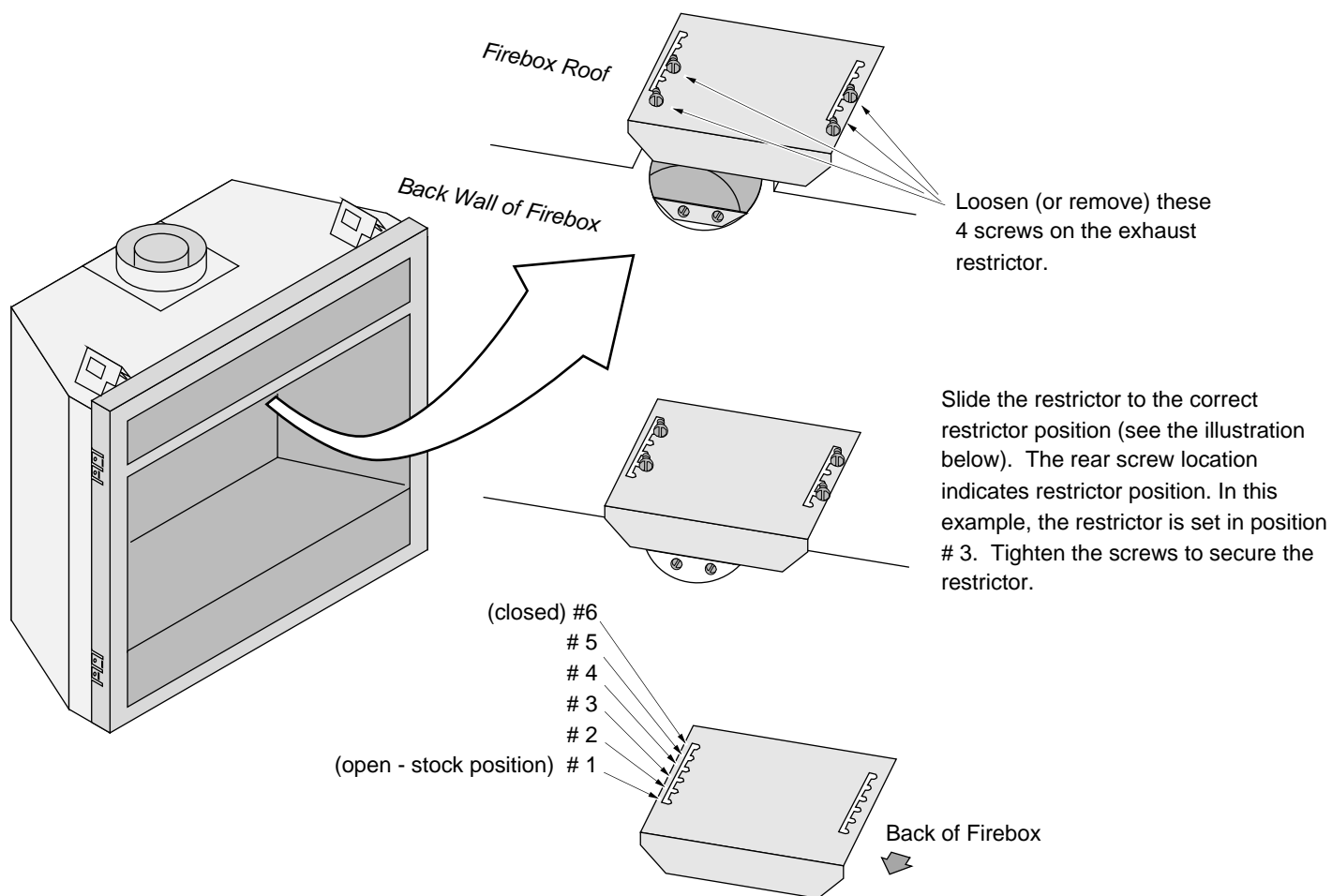

Intake Restrictor Adjustment

The intake restrictor is located behind the accent light, on the back wall of the firebox. To adjust the restrictor, follow the steps below:

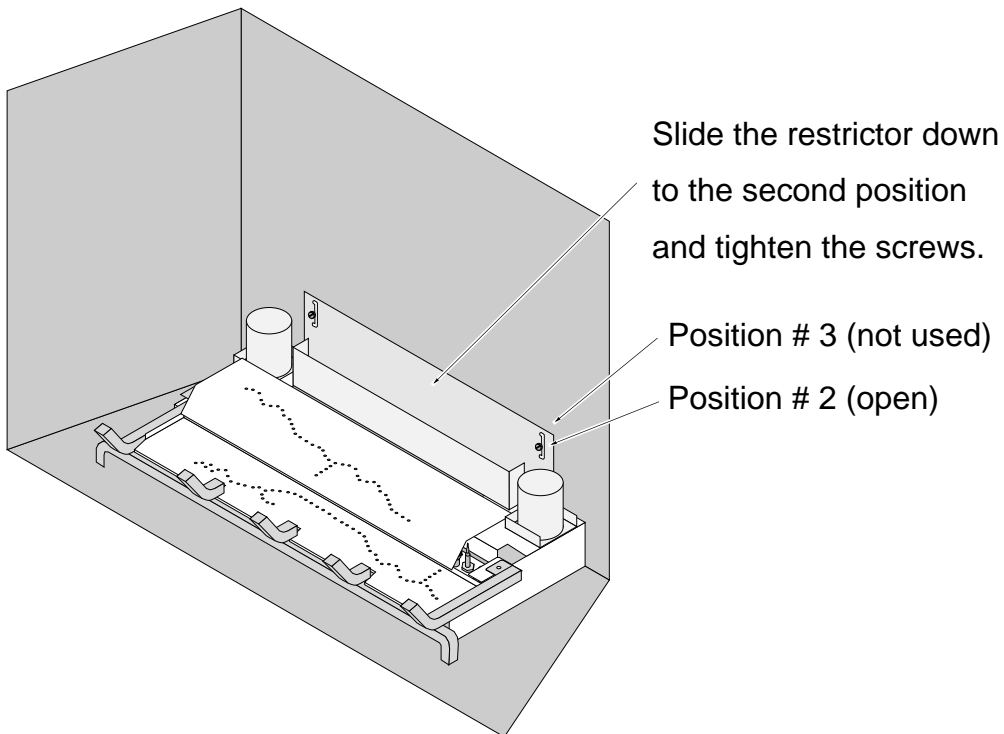
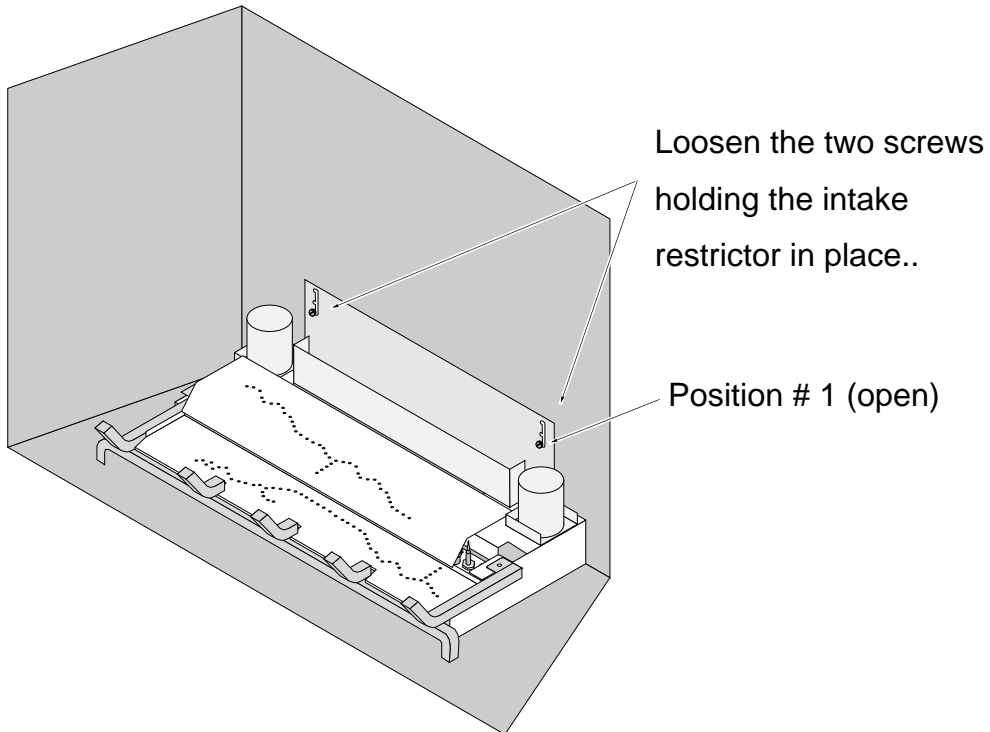

Diffuser Plate Adjustment

Certain vent configurations require the diffuser plate to be adjusted (refer to the approved vent configuration charts for details). Position # 1 is stock (bent). Position # 2 is flattened. See the directions below to change the diffuser to position #2.

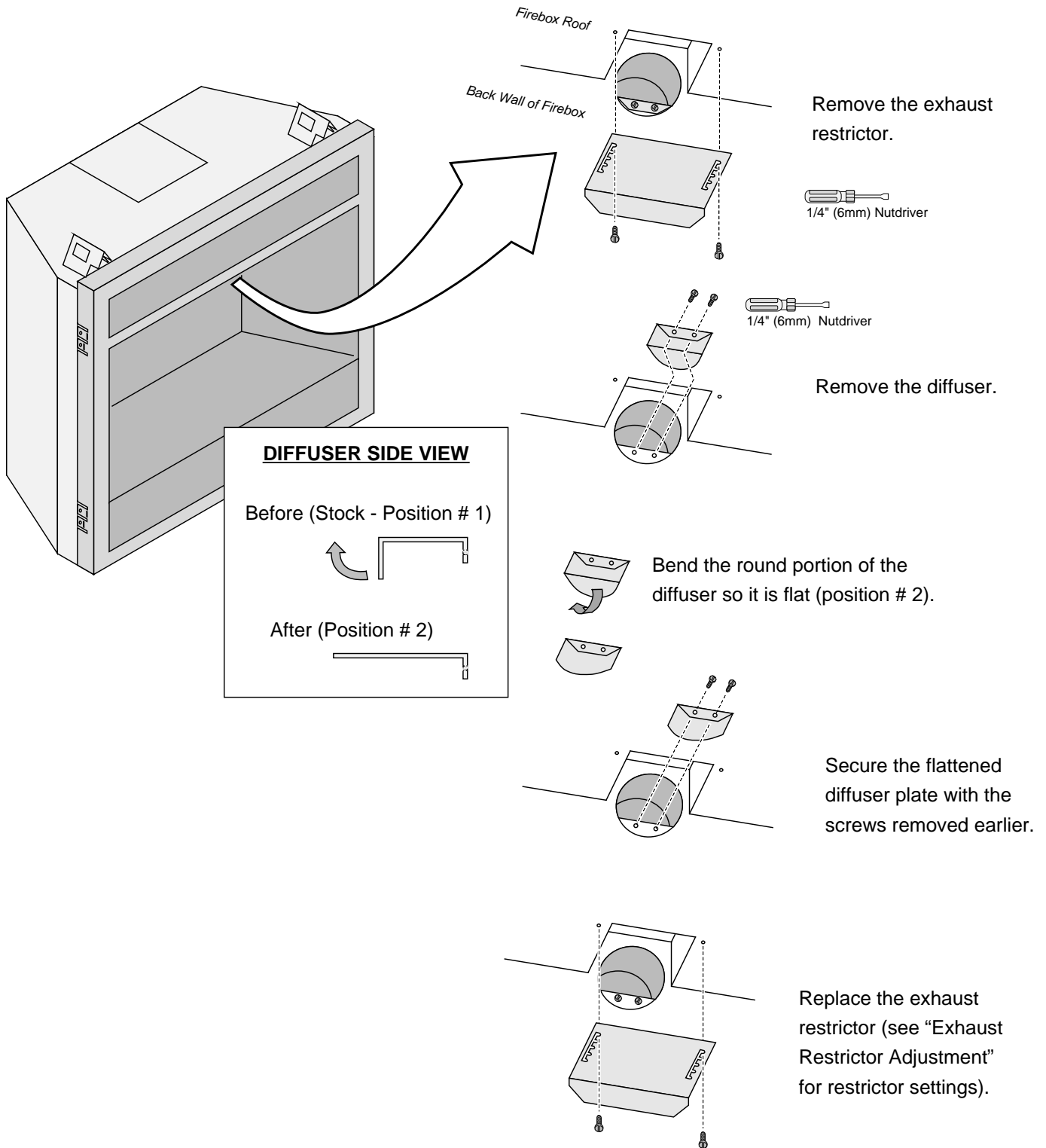

Rear Vent Configuration with Horizontal Termination (no vertical rise)

- The termination must fall within the shaded area shown in the chart. Use the indicated restrictor and diffuser positions.

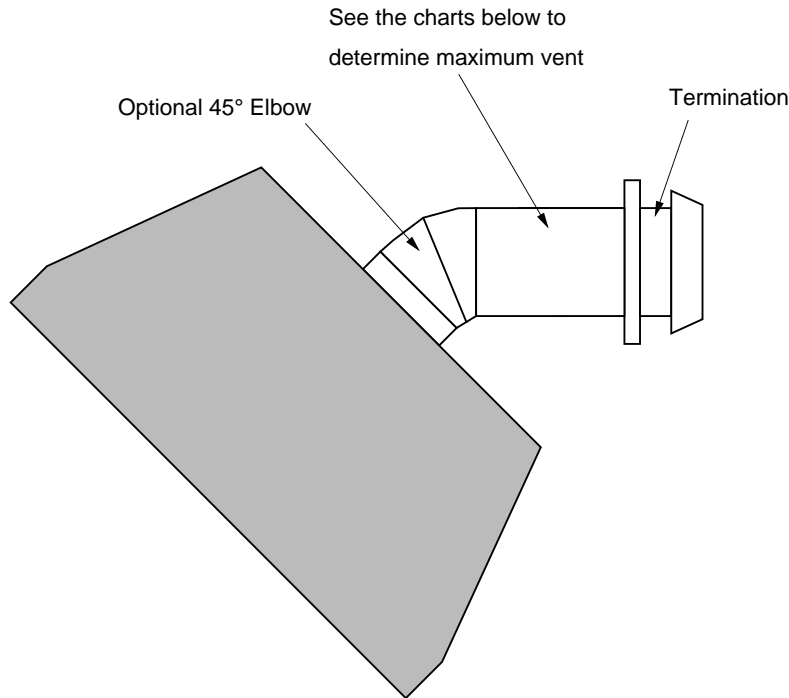

Vent with No 45° Elbow

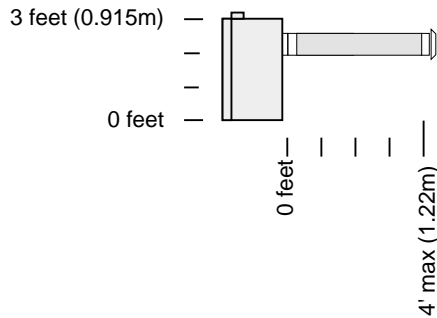

- Exhaust Restrictor # 1 (stock)
- Intake Restrictor # 1 (stock)
- Diffuser Position # 1 (stock)

- Min. 4" (102mm) Horizontal Section
- Max. 48" (1219mm) Horizontal Section(s)

Vent with 1 45° Elbow

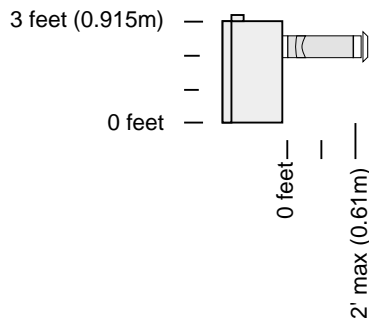

- Exhaust Restrictor # 1 (stock)
- Intake Restrictor # 1 (stock)
- Diffuser Position # 1 (stock)

- Min. 4" (102mm) Horizontal Section
- Max. 24" (610mm) Horizontal Section(s)

Rear Vent Configuration with Horizontal Termination (with vertical rise)

- The termination must fall within the shaded area shown in the chart. Use the indicated restrictor and diffuser positions.
- Up to four elbows (45° or 90°) may be used.
- Only one horizontal elbow may be used.

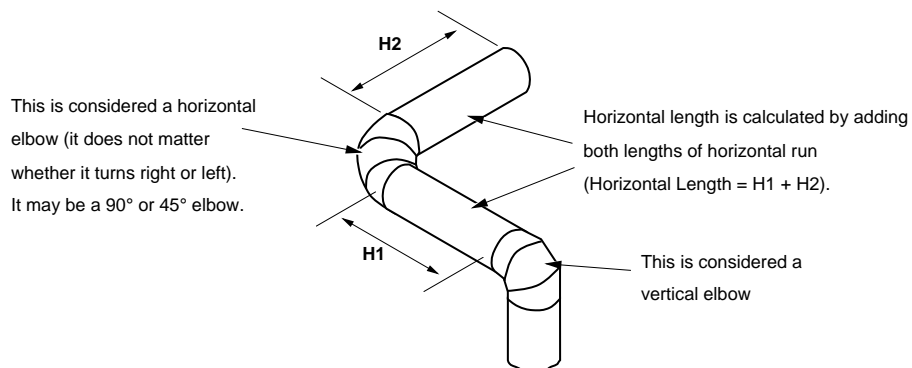
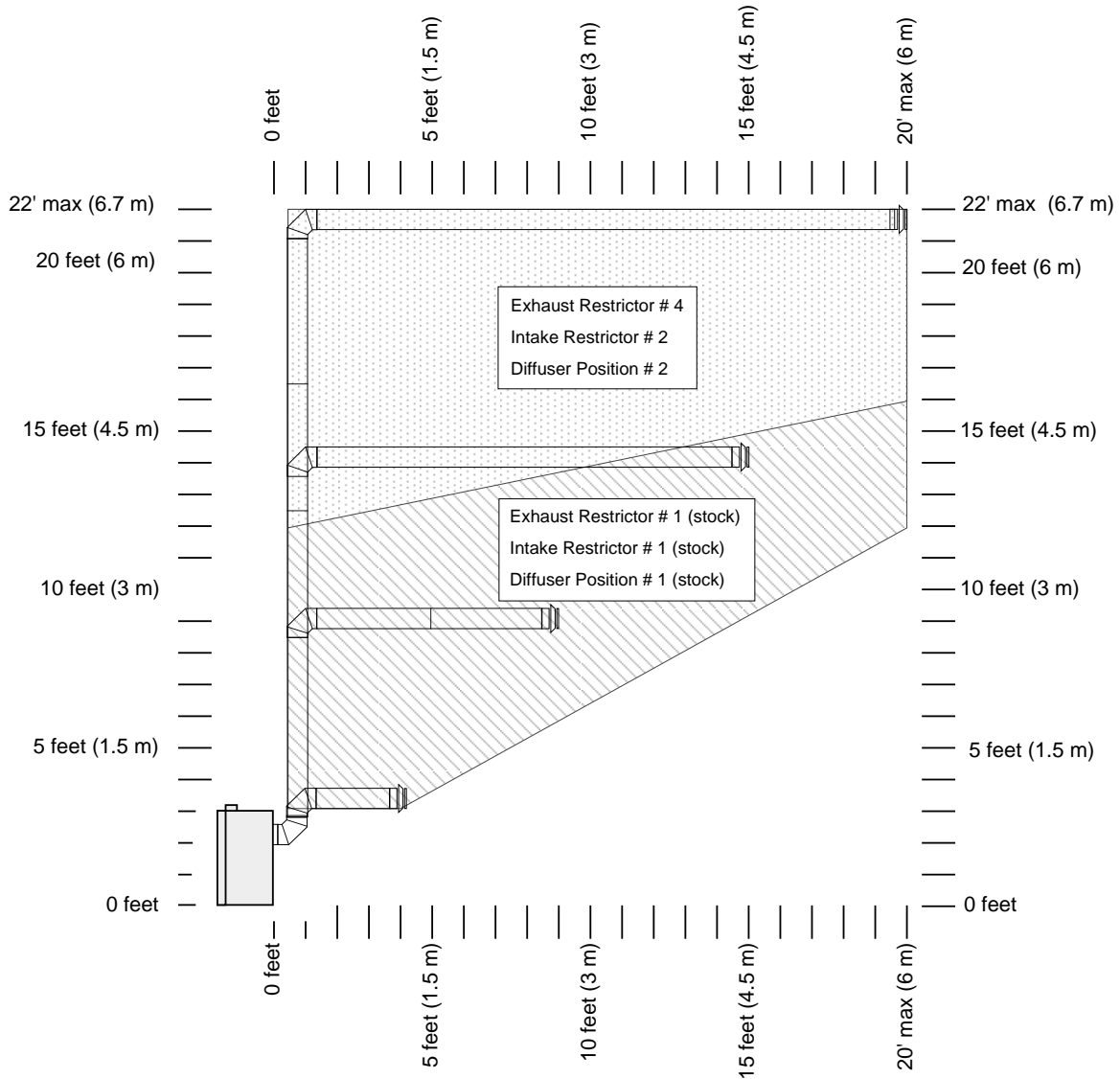

Rear Vent Configuration with Vertical Termination

- The termination must fall within the shaded area shown in the chart. Use the indicated restrictor and diffuser positions.
- Up to four elbows (45° or 90°) may be used.
- Only one horizontal elbow may be used.

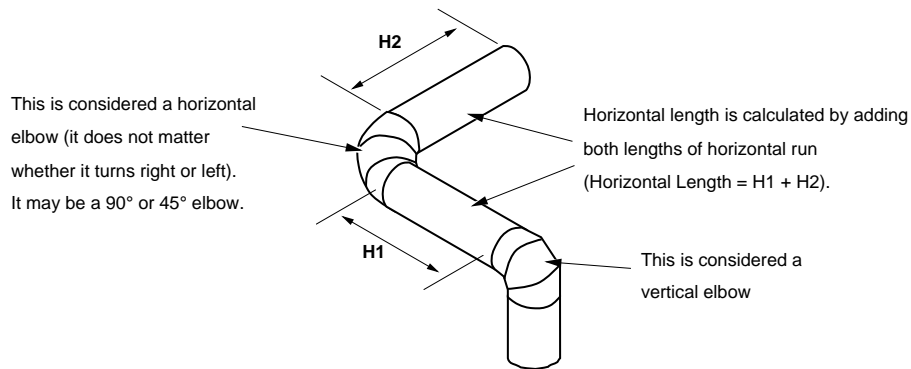
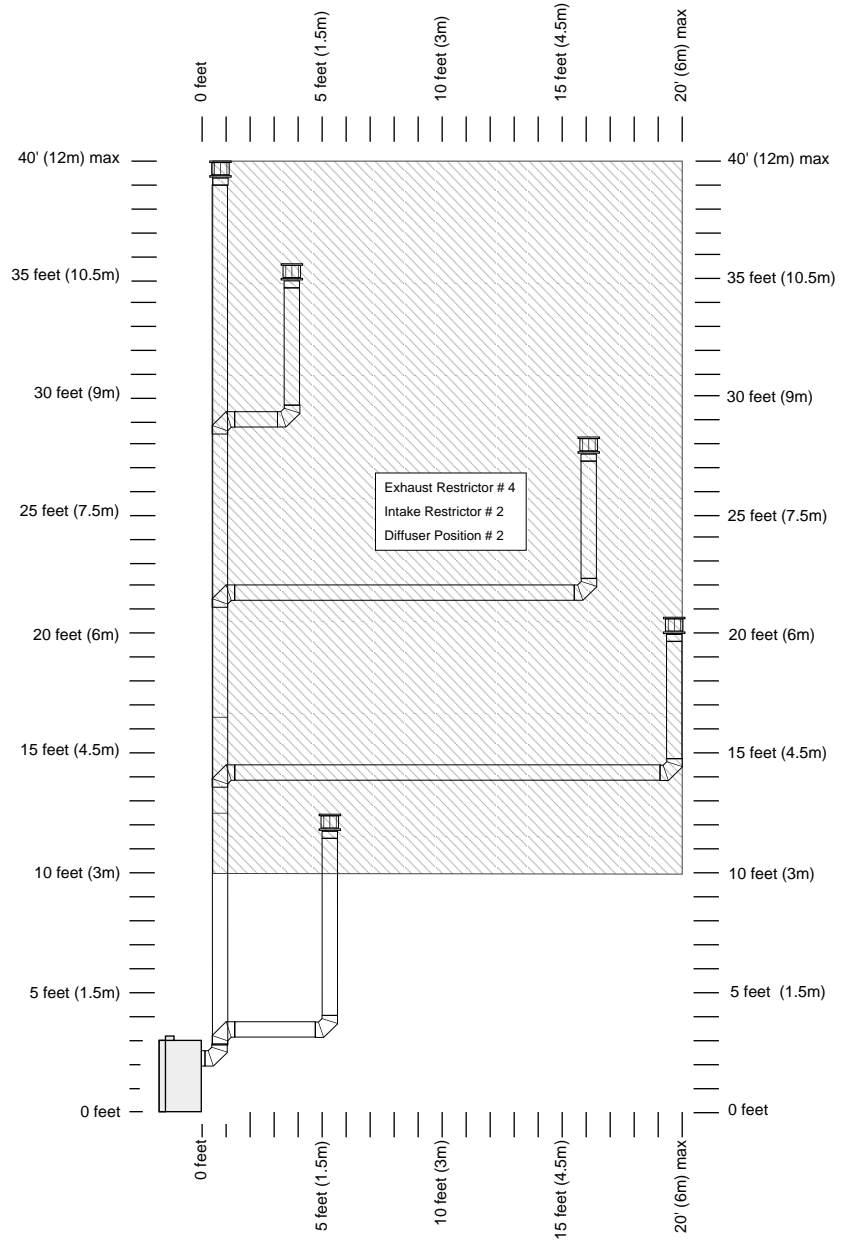

Top Vent Configuration with Horizontal Termination

- The termination must fall within the shaded area shown in the chart. Use the indicated restrictor and diffuser positions.
- Up to four elbows (45° or 90°) may be used.
- May use 8" (203mm) or 6-5/8" (168mm) diameter vent (see page for 25 details).
- Only one horizontal elbow may be used.

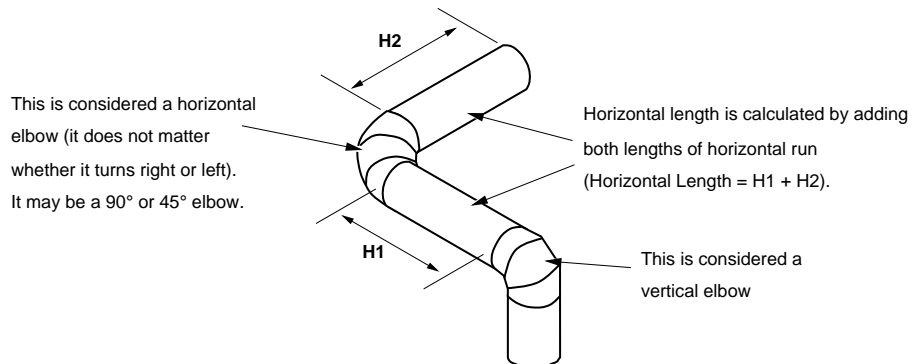
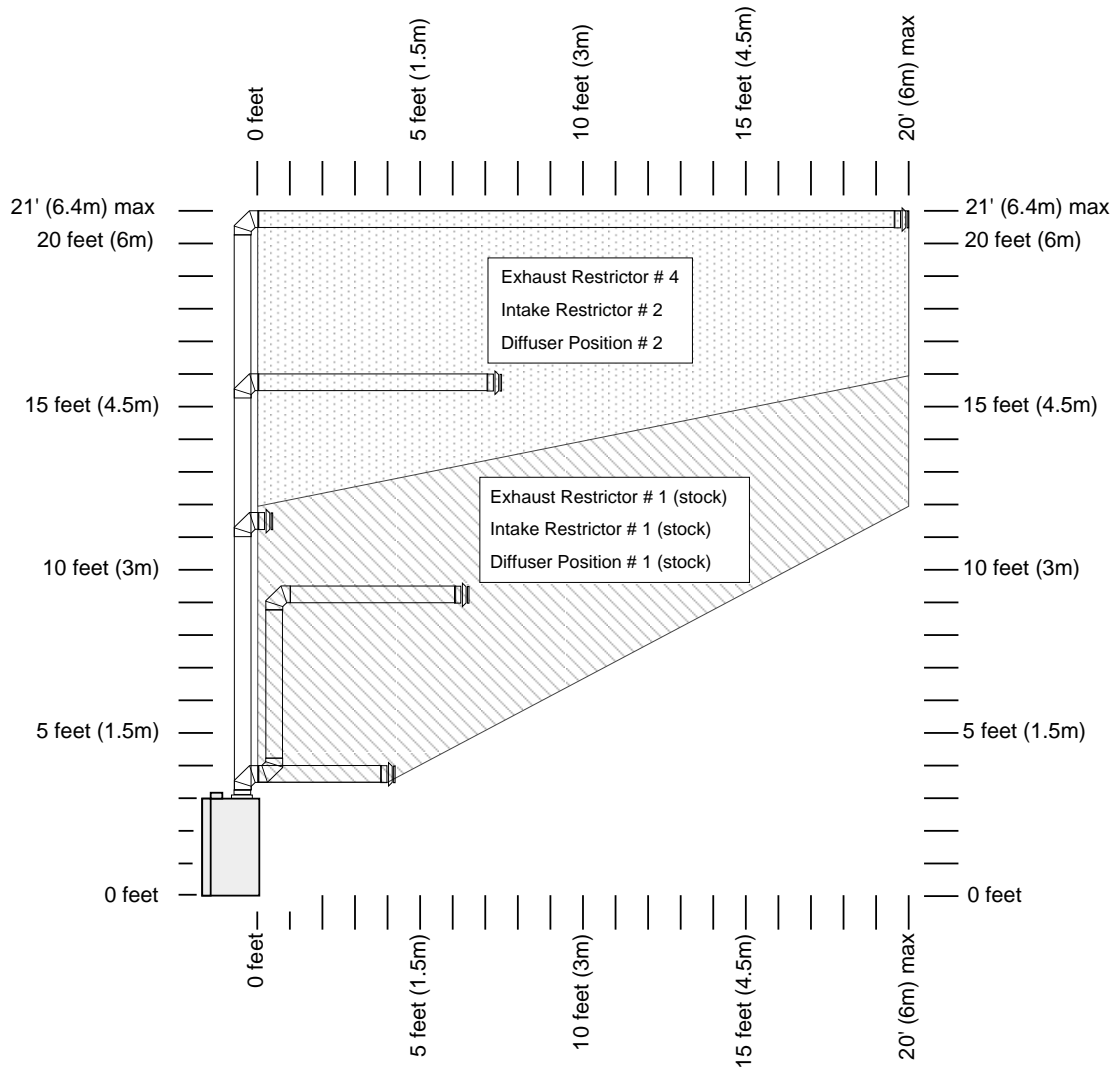

Top Vent Configuration with Vertical Termination

- The termination must fall within the shaded area shown in the chart. Use the indicated restrictor and diffuser positions.
- Up to four elbows (45° or 90°) may be used.
- Only one horizontal elbow may be used.
- May use 8" (203mm) or 6-5/8" (168mm) diameter vent (see page for 25 details).

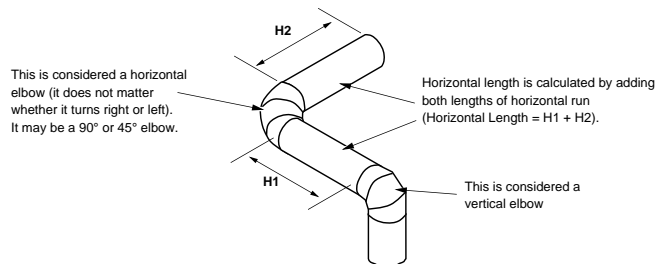
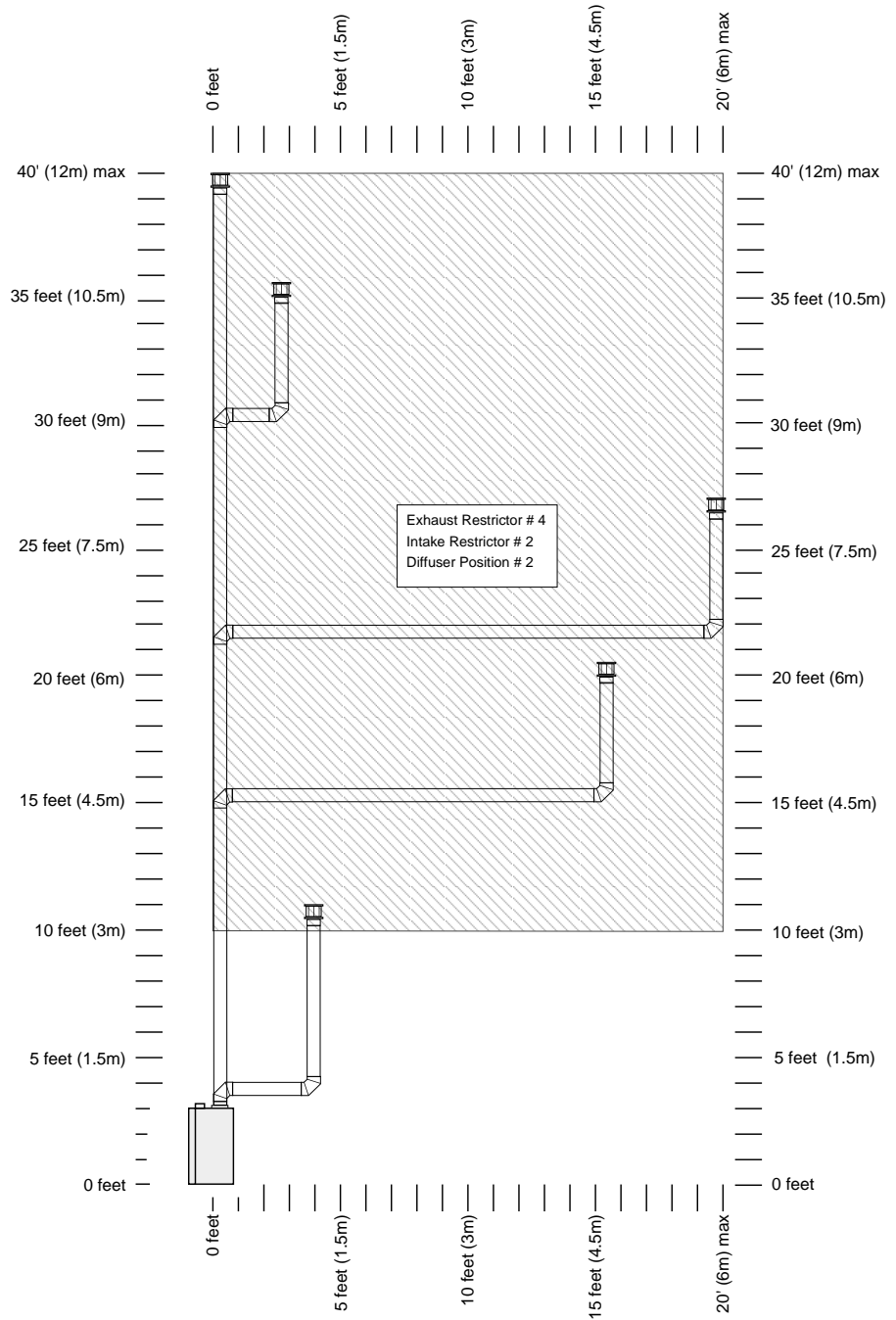

Termination Requirements

! Venting terminals shall not be recessed into a wall or siding.

- A Minimum 9" (229mm) clearance from any door or window
- B Minimum 12" (305mm) above any grade, veranda, porch, deck or balcony
- C Minimum 1" (25mm) from outside corner walls
NOTE: Clearance in accordance with local installation codes and the requirements of the gas supplier.
- D Minimum 1" (25mm) from inside corner walls
NOTE: Clearance in accordance with local installation codes and the requirements of the gas supplier.

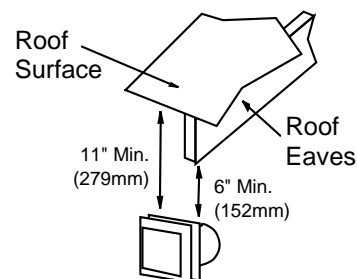

- E Minimum 11" (279mm) clearance below unventilated soffits or roof surfaces
Minimum 18" (457mm) clearance below ventilated soffits
Minimum 6" (152mm) clearance below roof eaves
NOTE: Vinyl surfaces require 24" (610mm)
NOTE: Clearance in accordance with local installation codes and the requirements of the gas supplier.
- F Minimum 12" (305mm) clearance below a veranda, porch, deck or balcony
NOTE: Permitted only if veranda, porch, deck, or balcony is fully open on a minimum of two sides beneath the floor.
NOTE: Clearance in accordance with local installation codes and the requirements of the gas supplier.
- G Minimum 48" (1219mm) clearance from any adjacent building
- H Minimum 84" (2134mm) clearance above any grade when adjacent to public walkways or driveways
NOTE: may not be used over a walkway or driveway shared by an adjacent building
- I Minimum 9" (229mm) clearance to any nonmechanical air supply inlet to the building or the combustion air inlet to any other appliance.
- J Minimum 36" (914mm) clearance above any mechanical air supply inlet if within 10' (3M) horizontally
- K Minimum 36" (914mm) from the area above the meter/regulator (vent outlet) - this extends 15' (4.5M) above the regulator
NOTE: Clearance in accordance with local installation codes and the requirements of the gas supplier.
- L Minimum 36" (914mm) from the meter/regulator (vent outlet)
NOTE: Clearance in accordance with local installation codes and the requirements of the gas supplier.
- M Minimum 12" (305mm) above the roof line (for vertical terminations)
- N Minimum 24" (610mm) horizontal clearance to any surface (such as an exterior wall) – for vertical terminations

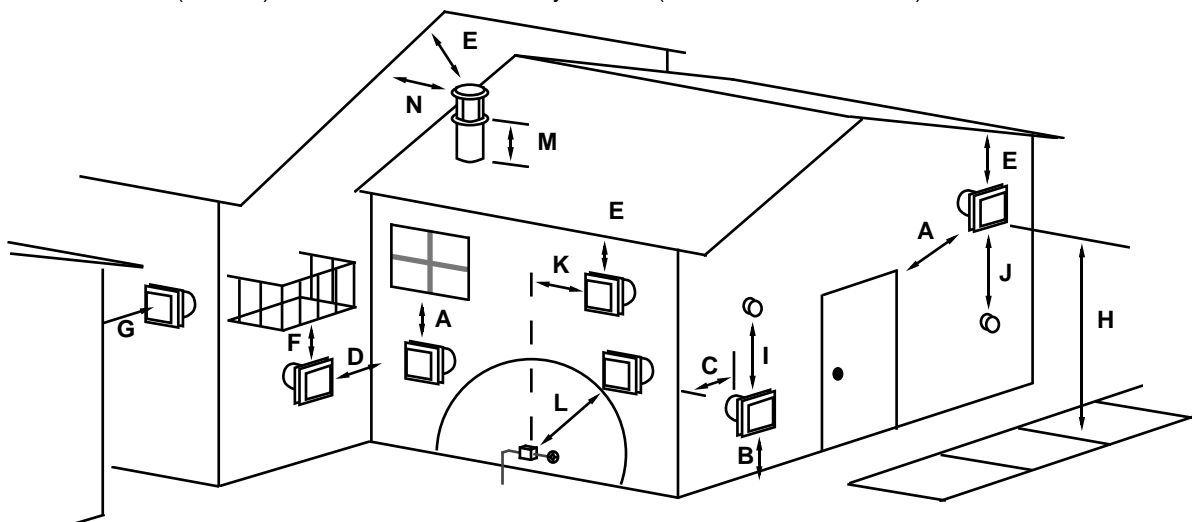

NOTE: Measure clearances to the nearest edge of the exhaust hood.

- Use the vinyl siding standoff when installing on an exterior with vinyl siding.
- Vent termination must not be located where it will become plugged by snow or other material

Hearth Requirements

Floor Mounted Fireplaces

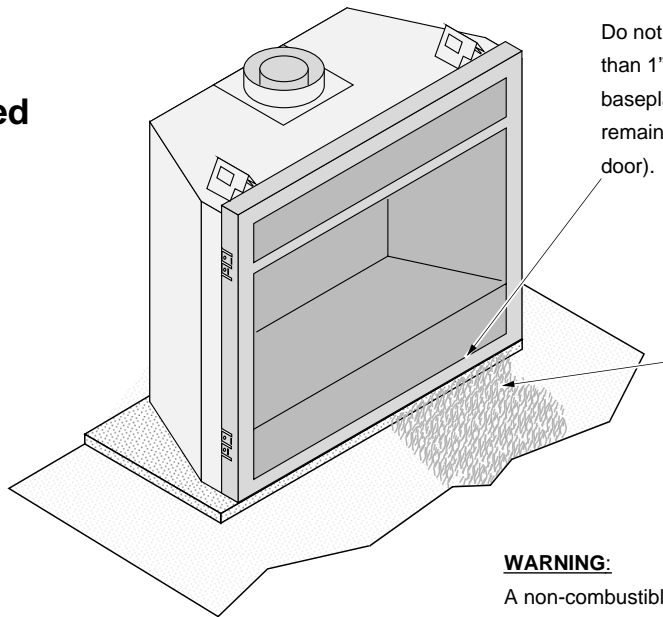

Do not build a hearth more than 1" (25mm) above the baseplate (this area must remain clear for the access door).

If installed near carpet or other combustible flooring, the fireplace must be raised so the base of the unit is above the carpet surface or flooring material.

WARNING:

A non-combustible hearth is not required. However, if the heater is installed next to the floor, we recommend a hearth to protect the flooring surface from discoloration or other negative impact from the heater.

Raised Fireplaces

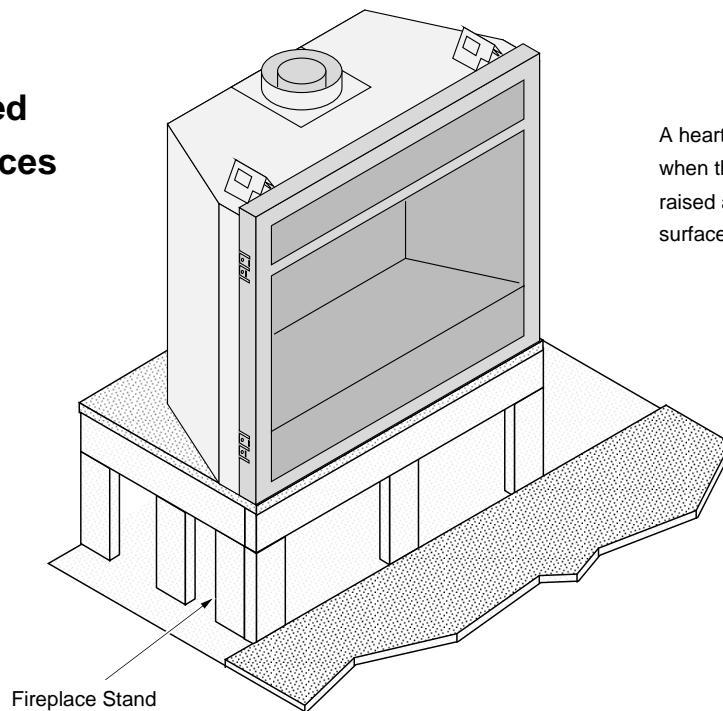

A hearth is not required when the fireplace is raised above the flooring surface.

Facing Requirements

- This appliance is designed to allow for drywall (or other combustible facing) to contact the sides and top of the front of the fireplace.
- Tile or other non-combustible facing may be placed on the front of the fireplace (see "Facing Overview" on page 38 for further details).

Drywall Installation

Drywall Installation Drywall may be installed up to the front edge of the fireplace. If the fireplace is raised, drywall up to the bottom edge as well.

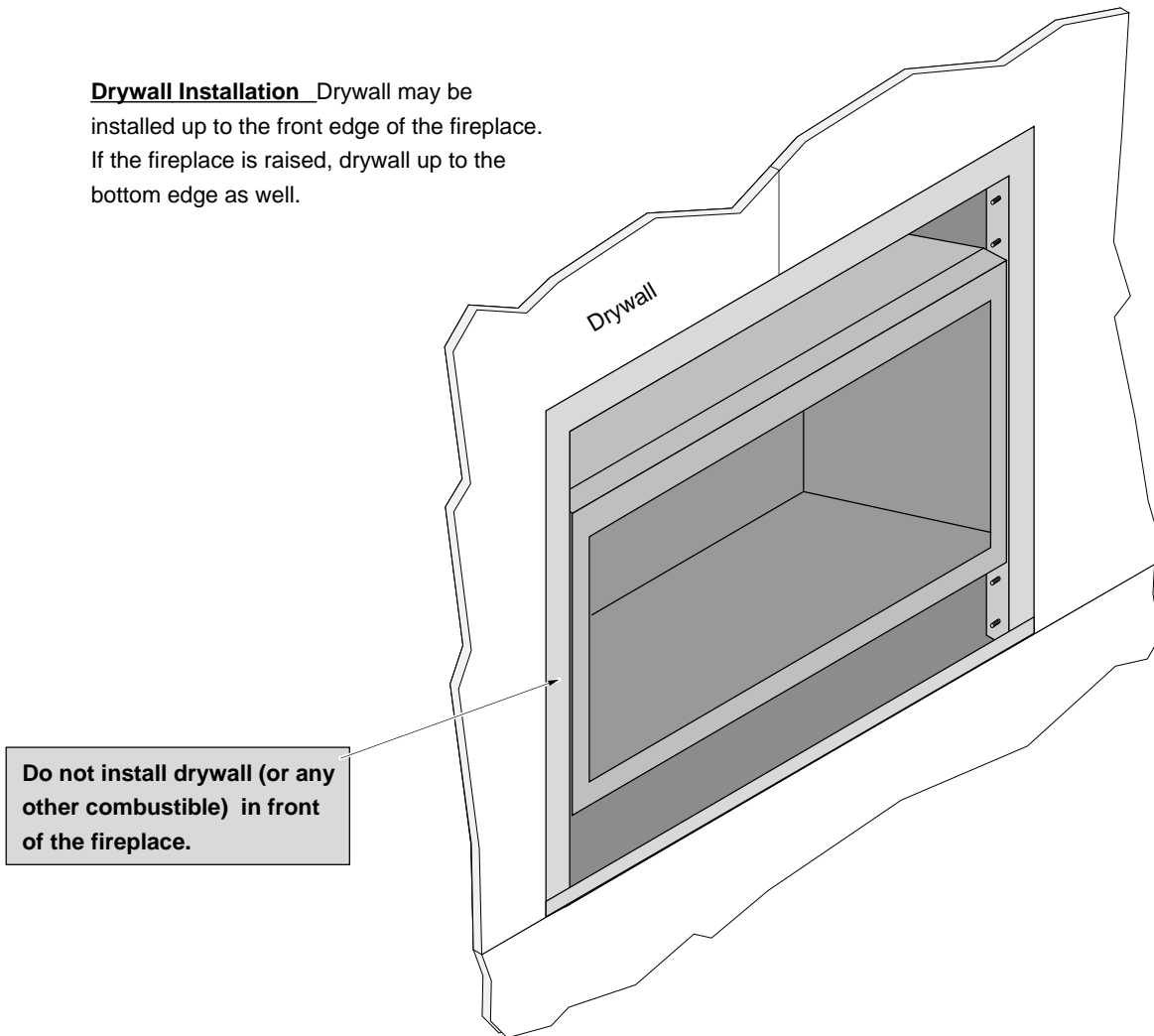

TOP VIEW

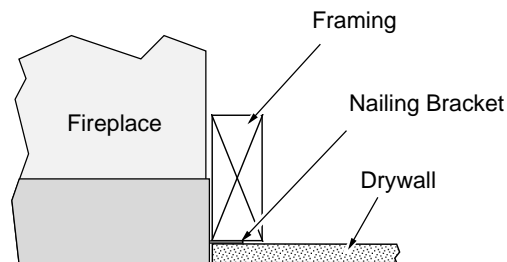

Facing Overview



Upgrade faces are available for this fireplace and may influence facing installation. Consult with your Travis Dealer if you are using an upgrade face.

Optional non-combustible facing may be installed on the fireplace. Use the guidelines below to determine the location (also see the following pages for detailed diagrams).

Tile Line Any non-combustible facing under 1" (25mm) thick (see "Thin Facing" on page 39).

Masonry Line Any non-combustible over 1" (25mm) thick (see "Thick Facing" on page 41).

Hearth Line Non-combustible hearth/facing should be installed up to this location (1" (25mm) above the base of the fireplace). The fireplace may be raised to accommodate thicker hearth materials.

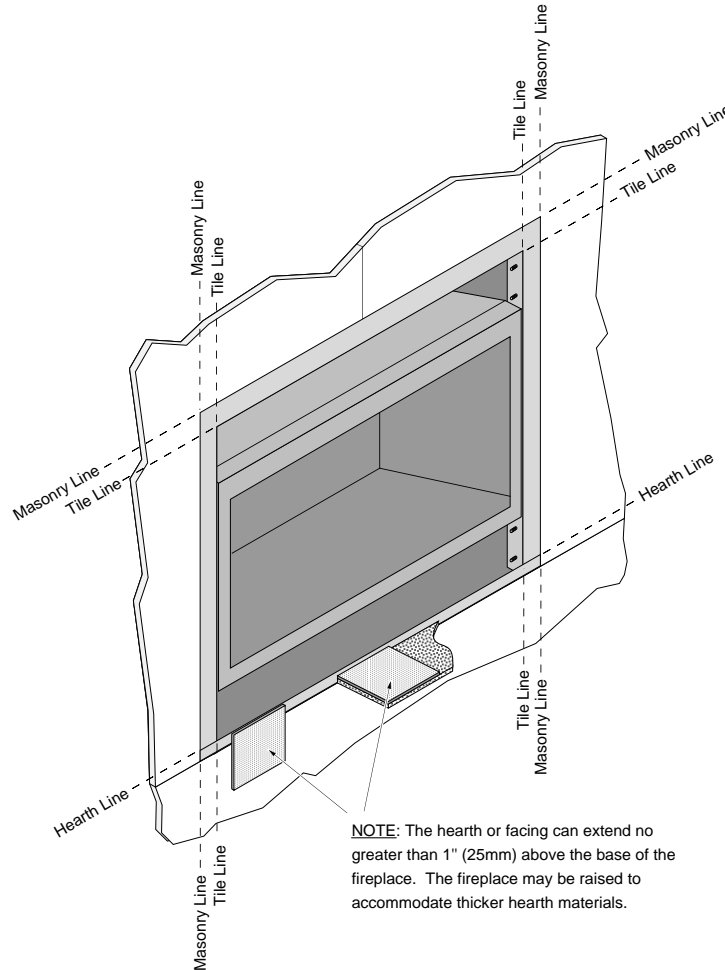

Optional Faceplates



Upgrade faces are available for this fireplace that may influence facing installation. Refer to the face installation instructions for face sizing and installation considerations.

Name	Height	Width	Notes
FPX Artisan, Classic, Fr Ctry	35.75" (908mm)	41" (1041mm)	45-3/4" (1162mm) Radius – May fit over top of tile facing
Winthrop Victorian Lace	34.125" (867mm)	36-7/8" (937mm)	Optional facing will butte to edge of faceplate (tile line)
Wilmington Hearthview	35.75" (908mm)	41" (1041mm)	May fit over top of tile facing
Winthrop Bungalow	34" (864mm)	36-7/8" (937mm)	Optional facing will butte to edge of faceplate (tile line)
Shadowbox	38.0625" (967mm)	50" (1270mm)	Face extends 1" below base of fireplace

Thin Facing Installation (tile, marble, or other non-combustible under 1" (25mm) thick)



Upgrade faces are available for this fireplace and may influence facing installation. Consult with your Travis Dealer if you are using an upgrade face.

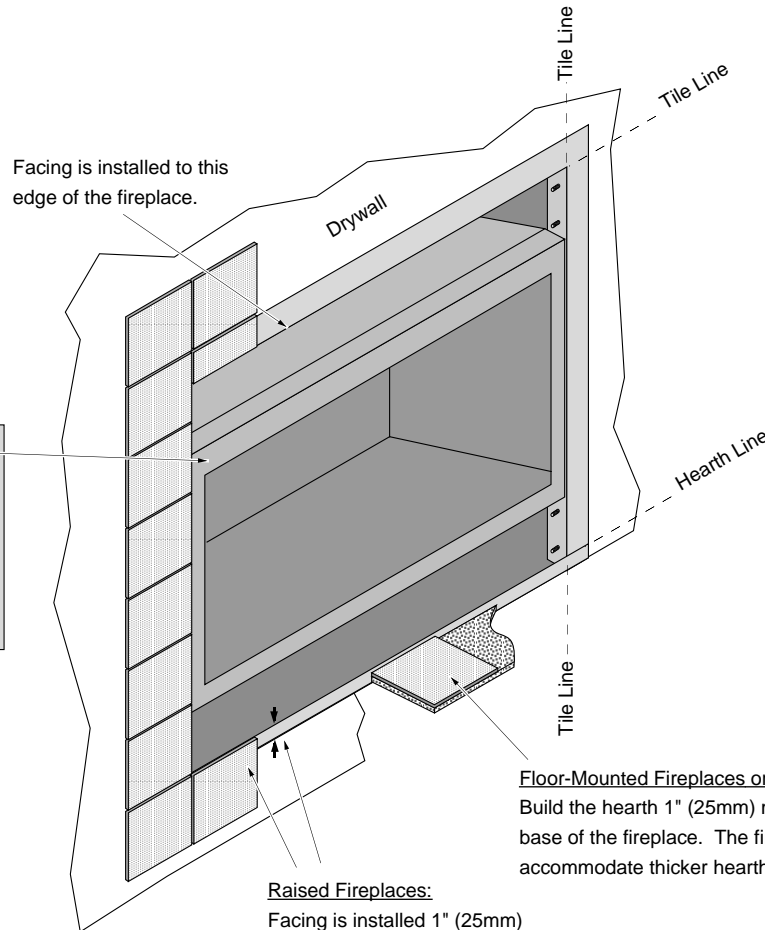

Do not install tile (or other material) in front of the glass frame, convection channel, or access panel openings. This area must remain open to access internal components and for convection air.

Floor-Mounted Fireplaces or Raised Hearths:
Build the hearth 1" (25mm) maximum above the base of the fireplace. The fireplace may be raised to accommodate thicker hearth materials.

Raised Fireplaces:
Facing is installed 1" (25mm) maximum above the base of the fireplace.

TOP VIEW

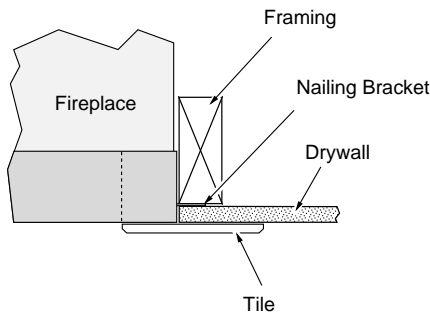

FRONT VIEW

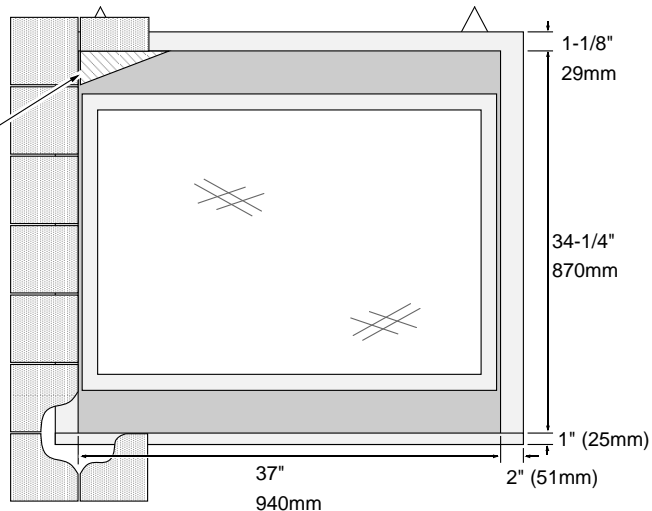

NOTE FOR FPX FACES:
FPX arched faces require the FPX Face Upgrade Kit (sku 98500686) and a triangular piece of facing in these upper corners. See the instructions included with the face for further details.

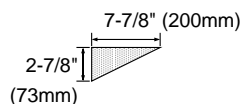

Thin Facing Installation (tile, marble, under 1" (25mm) thick) - Side View

**Raised Fireplace
(with no Hearth)**

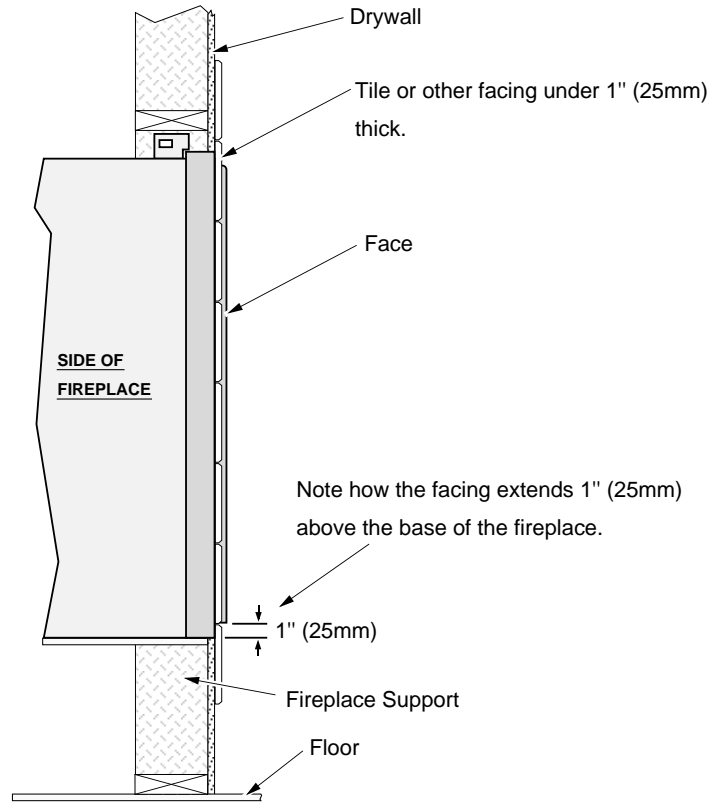

**Floor-Mounted Fireplace
(with Hearth)**

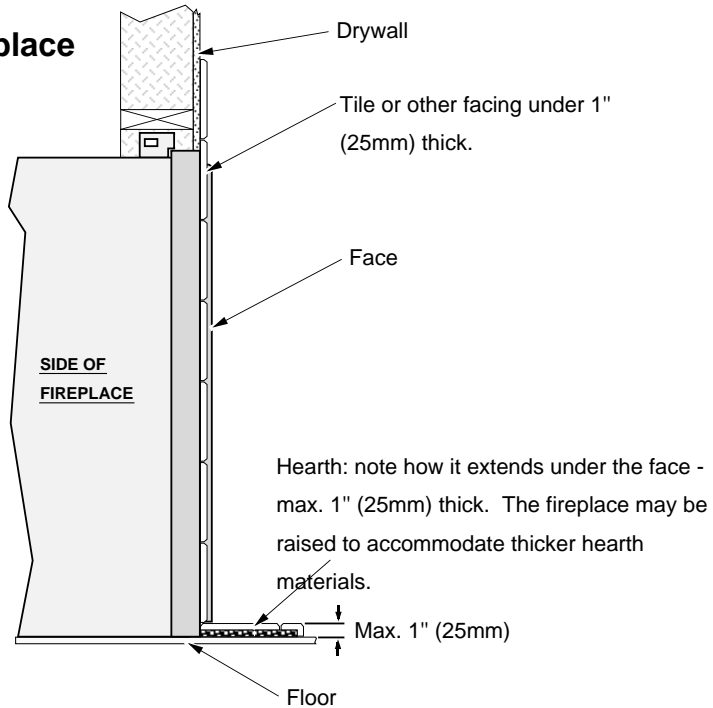

Thick Facing Installation (stone, brick, or other non-combustible over 1" (25mm) thick)



If using a Fireplace Xtordinaire (FPX) arched face, see "Thick Facing with a Fireplace Xtordinaire Arched Faces" on page 42.

Do not install masonry (or other material) in front of the fireplace. This area must remain open to install the face.

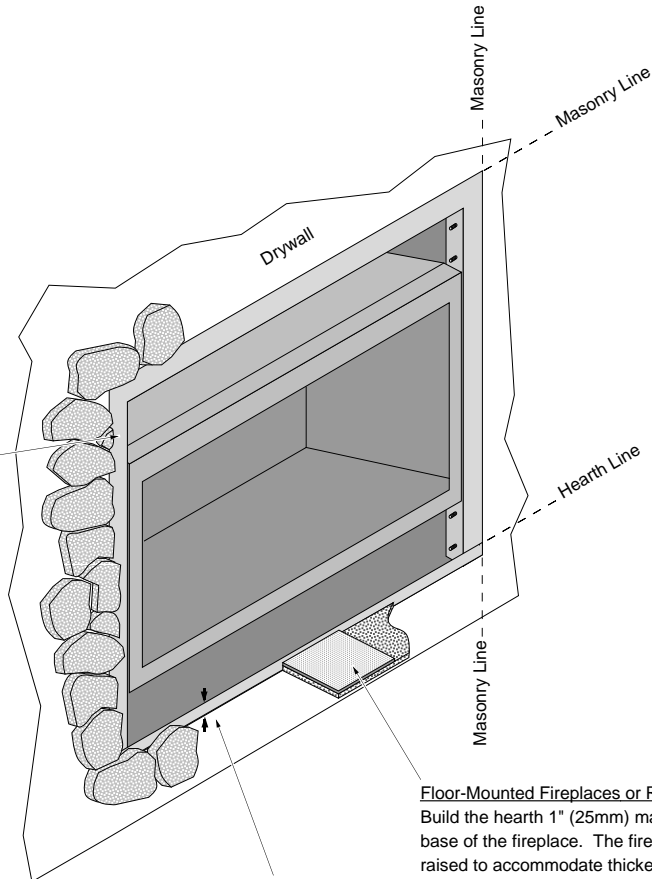

TOP VIEW - Protruding Masonry

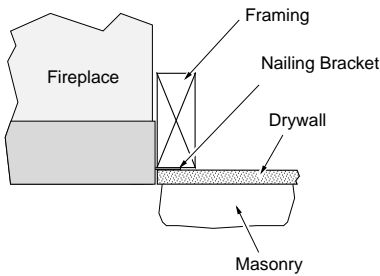

Floor-Mounted Fireplaces or Raised Hearths:
Build the hearth 1" (25mm) maximum above the base of the fireplace. The fireplace may be raised to accommodate thicker hearth materials.

Raised Fireplaces:
Masonry is installed 1" (25mm) maximum above the base of the fireplace.

TOP VIEW - Recessed Masonry

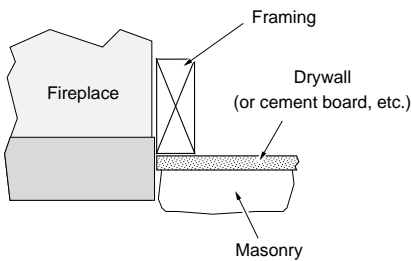

NOTE: The nailing brackets are not used for this type of installation - secure the fireplace to the floor with the brackets along the base of the fireplace.

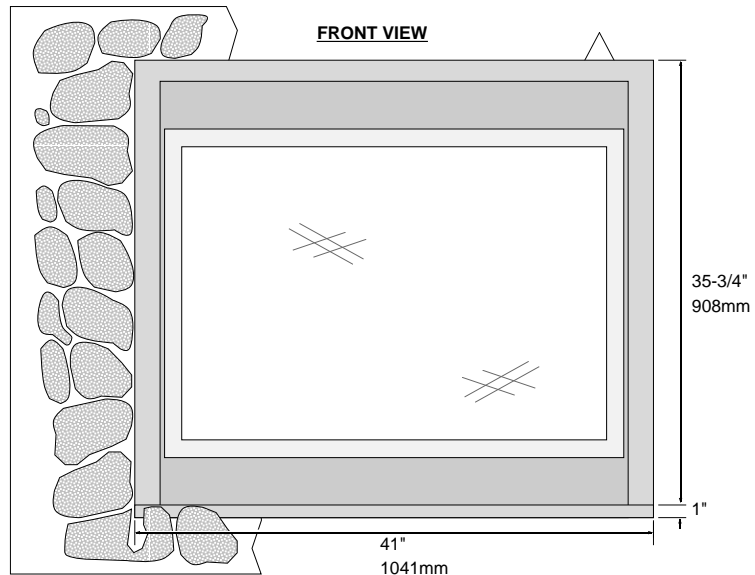

Thick Facing with Fireplace Xtrordinair (FPX) Arched Faces



The following illustration shows facing considerations for those fireplaces utilizing FPX arched faces. The facing must be non-combustible and over 1" (25mm) in depth.

The Fireplace Xtrordinair 864 Masonry Template is recommended for masonry installation (sku 98500688). The template helps locate and support the masonry as it being installed.

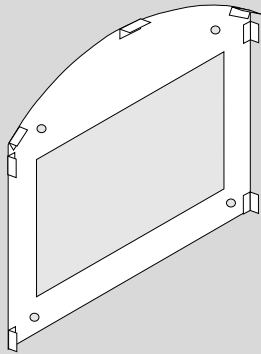

Before installing masonry, install the FPX Face Upgrade Kit (98500686). This covers the upper corners.

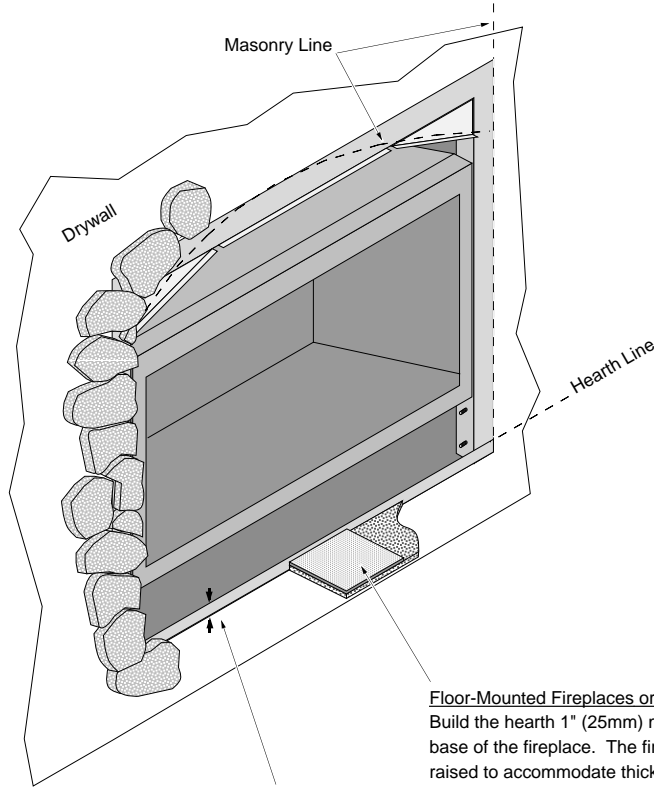
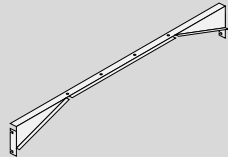

Floor-Mounted Fireplaces or Raised Hearths: Build the hearth 1" (25mm) maximum above the base of the fireplace. The fireplace may be raised to accommodate thicker hearth materials.

Raised Fireplaces: Masonry is installed 1" (25mm) maximum above the base of the fireplace.

TOP VIEW

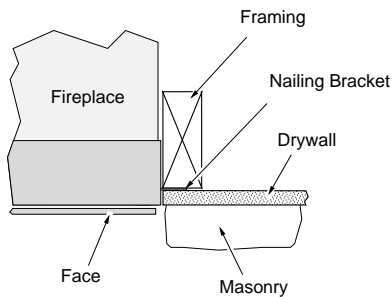

FRONT VIEW

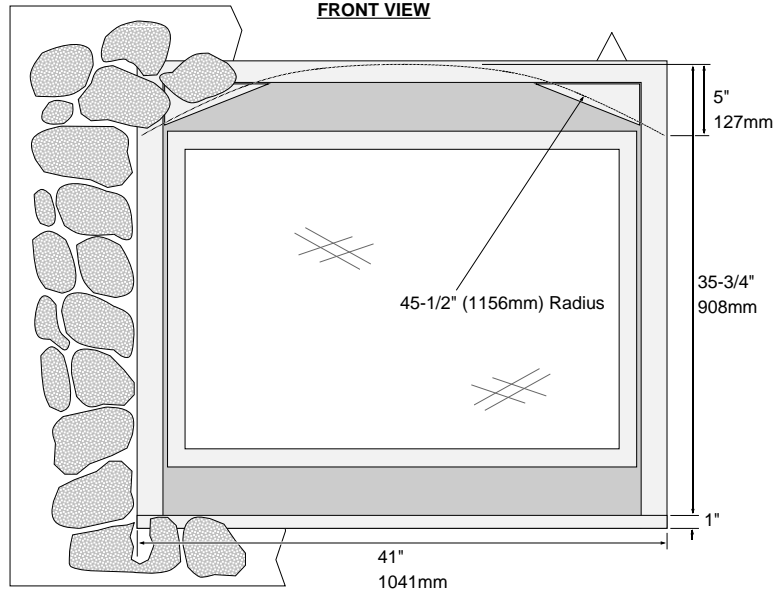

Thick Facing Installation - Side View

Floor-Mounted Fireplace (with Hearth)

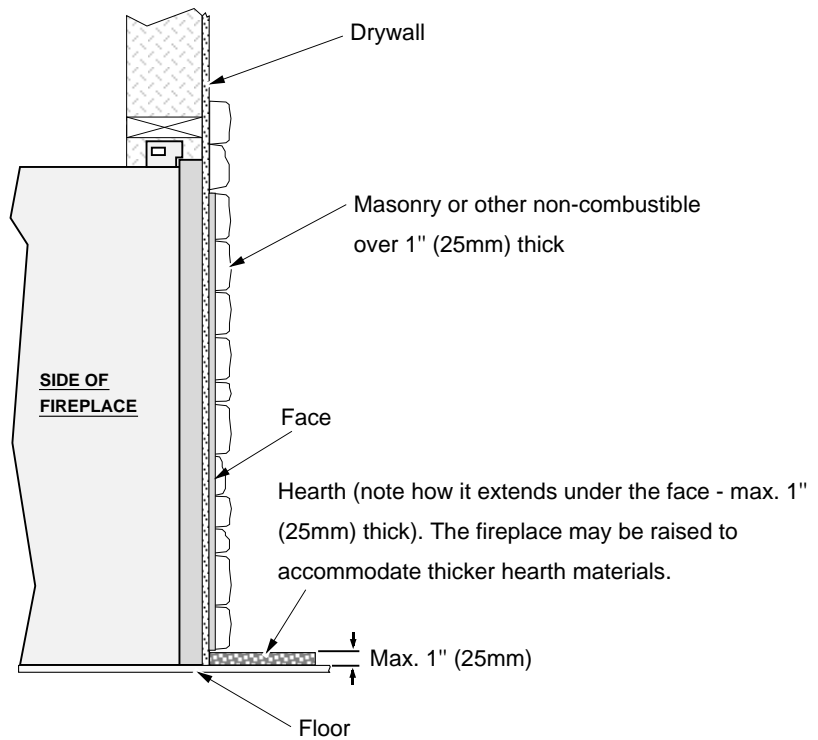

Raised Fireplace (with no Hearth)

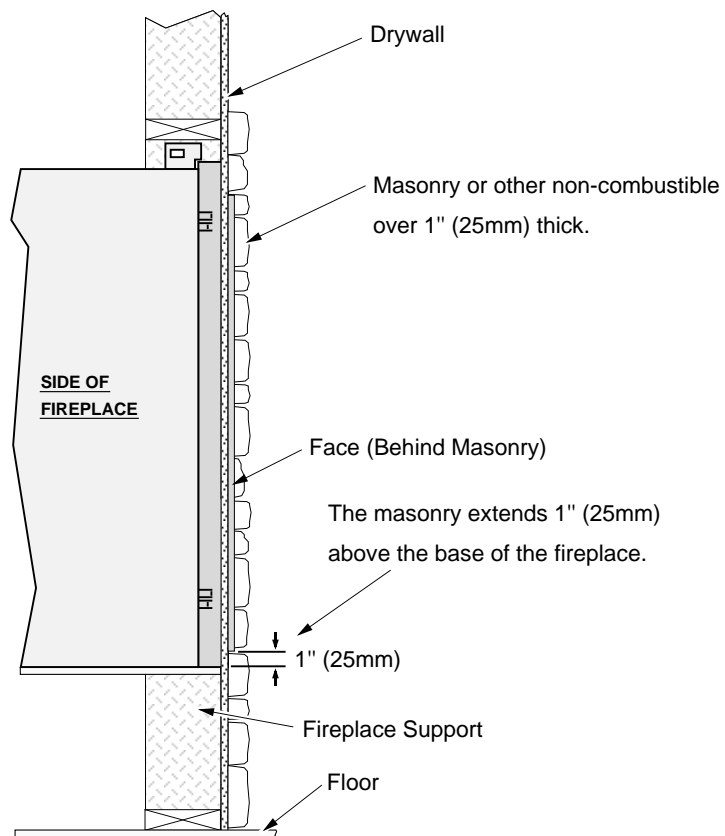

Mantel Requirements

Combustible Mantels

- Use the table below to determine the maximum mantel depth allowed. The mantel depth (measured from the face of the fireplace) must fall in the shaded portion of the table.
- Any material that protrudes more than 3/4" (19mm) from the non-combustible facing is considered a mantel and must meet the mantel requirements.

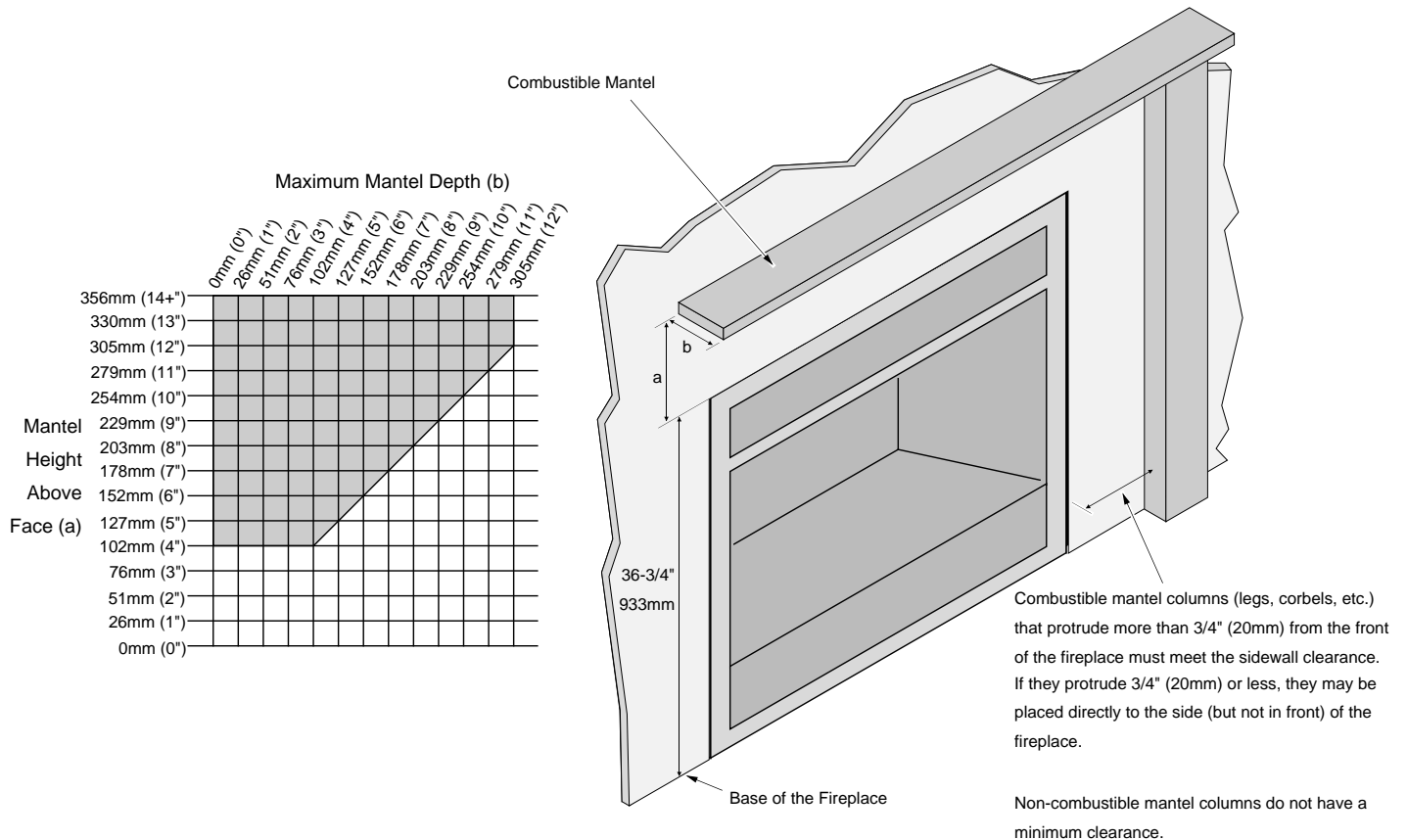

Examples:

- If you wish to have an 8" (203mm) deep mantel, it must be at least 8" (203mm) above the fireplace face (44-3/4", 1137mm above the base).
- If you wish to have a mantel 6" (152mm) above the fireplace face, it must be no deeper than 6" (152mm).

Non-Combustible Mantels

Non-combustible mantels must meet the clearances listed for combustible mantels. However, if you do wish to reduce the clearances by using a non-combustible mantel, the following requirements must be met:

- Non-combustible mantel and facing must extend from the top of the appliance to the top surface of the mantel.
- A non-combustible header must be used (metal stud).

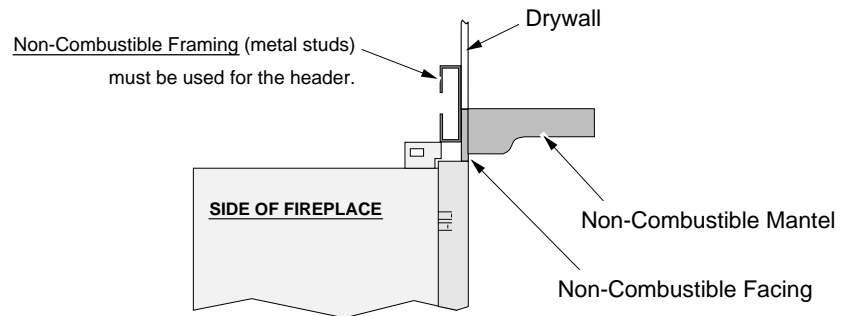

Installation Example - Build-Out (Dog-House) with Hor. Termination

- The framing, facing, and other building materials depicted below are for example only. Refer to local building codes for framing, facing, and insulating requirements in your area.

Side View

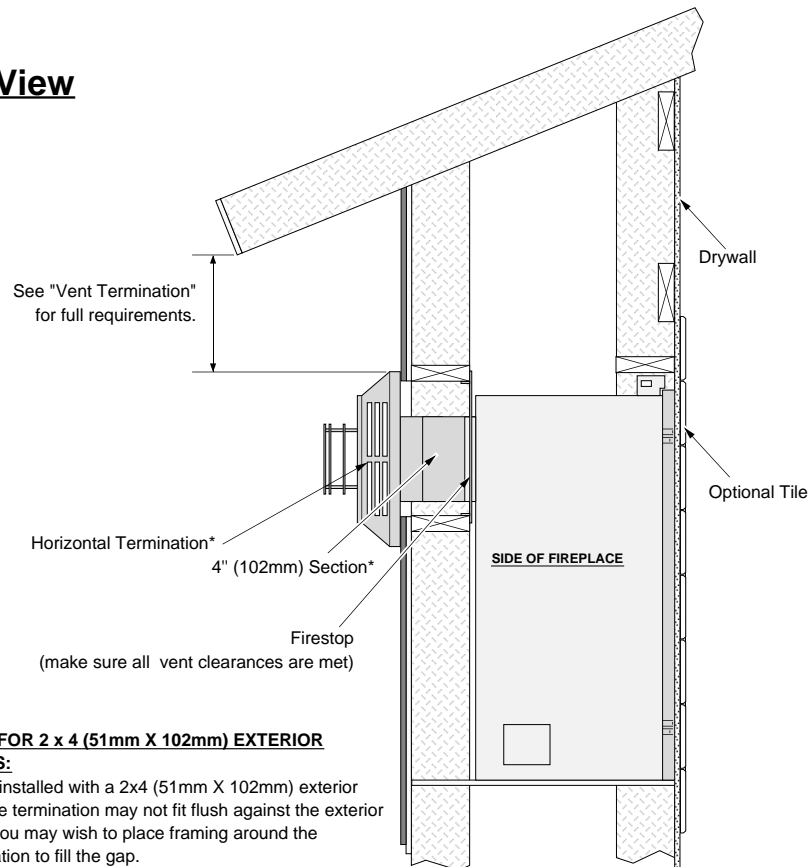

Top View

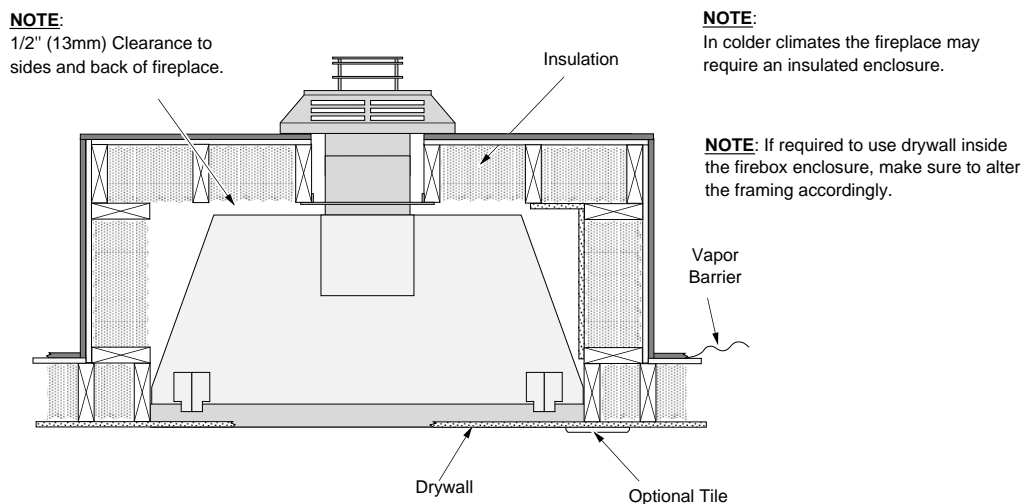

Installation Example - Build-In with Horizontal Termination

- The framing, facing, and other building materials depicted below are for example only. Refer to local building codes for framing, facing, and insulating requirements in your area.

Side View

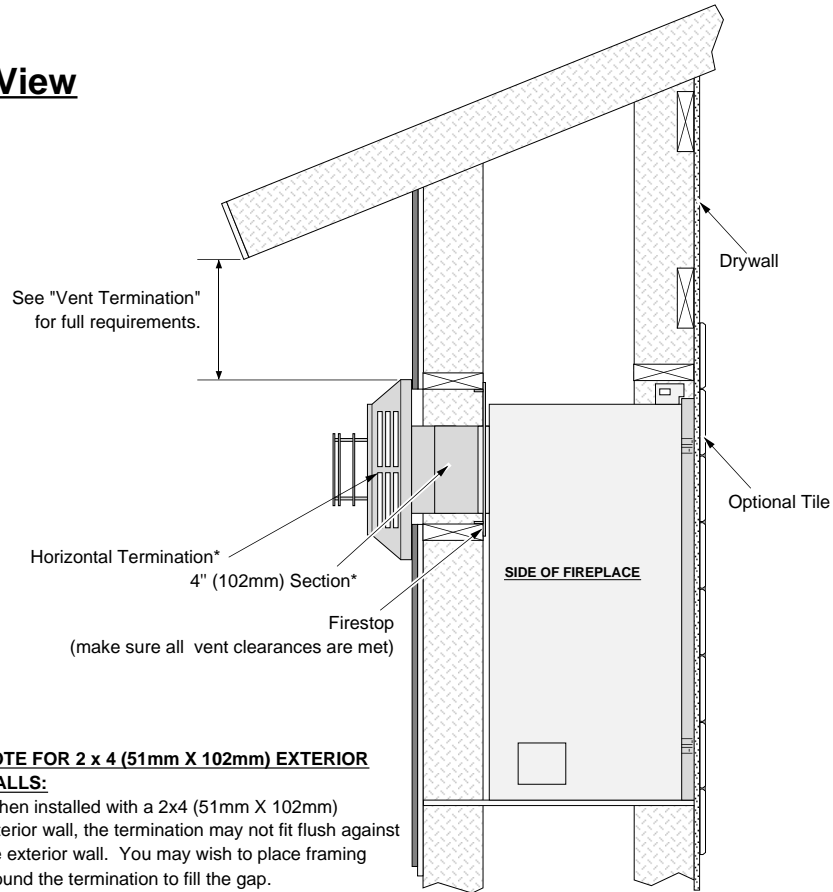

Top View

NOTE:
1/2" (13mm) Clearance to sides and back of fireplace.

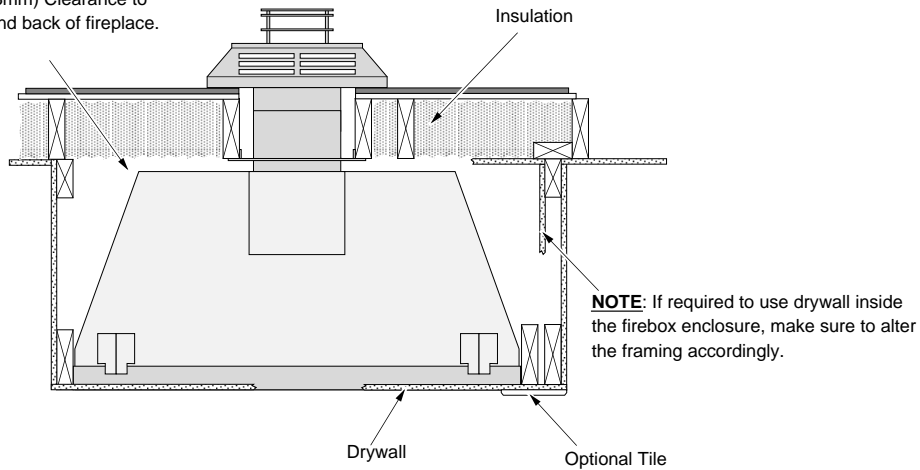

Steps for Finalizing the Installation

1. Remove the glass (see page 49).
NOTE: If using propane (LP) convert the appliance prior to installing the logs.
2. We recommend you purge the gas line at this time (with the glass removed). This allows gas to be detected once it enters the firebox, ensuring gas does not build up.
3. Make sure the two accent light bulbs are in place.
NOTE: Take care to not touch the bulb with your fingers (use a cloth or paper towel).

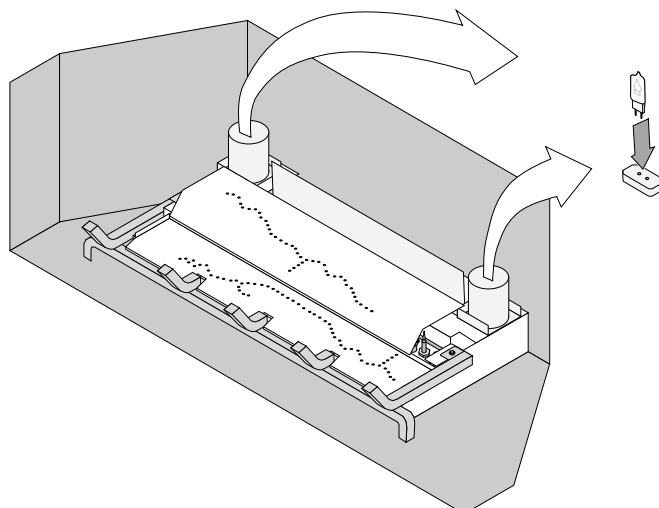

4. Install the four AA batteries (included in the owner's pack) into the battery holder (see the illustration below). The AA batteries act as a power backup in case the household (AC) power goes out. Install the 9v battery (included in the owner's pack) into control panel light assembly (see the illustration below). The battery holder is held in place with Velcro and may be removed for easier access.

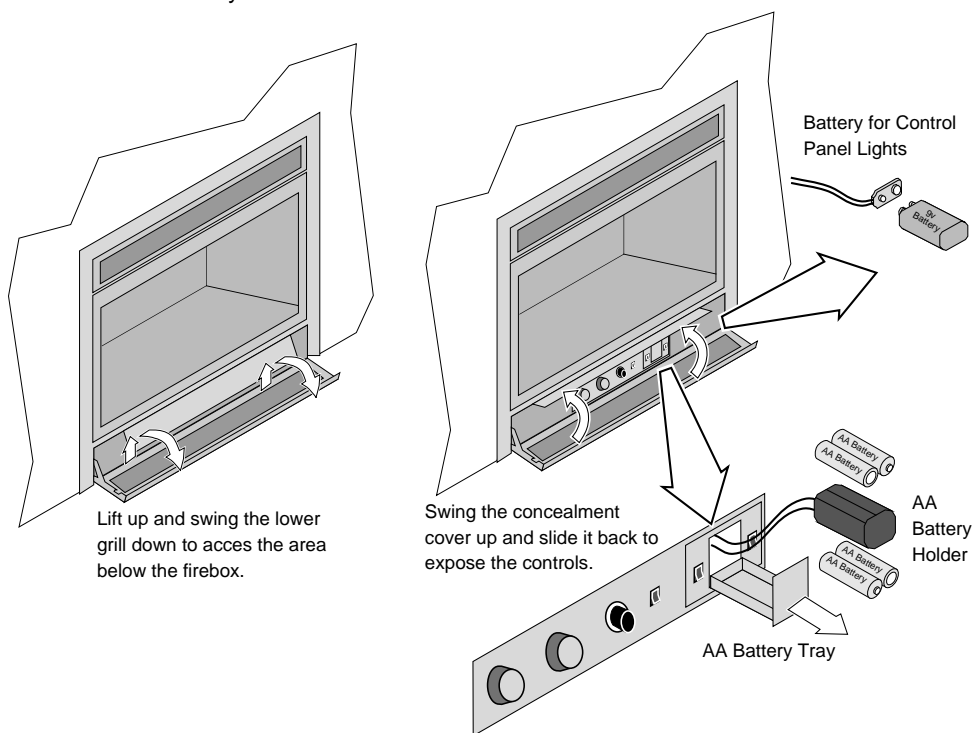

5. Install the logs (see page 52).
6. Replace the glass.
7. Start the heater.
8. Leak test all gas joints.

48 Finalizing the Installation (for qualified installers only)

9. Check the air shutter following the directions below.

Air Shutter Adjustment

Let the heater burn for fifteen minutes (make sure the logs and glass are in place). The flames should be yellow with no sooting. Adjust the air shutter, if necessary, to achieve the correct looking flame.

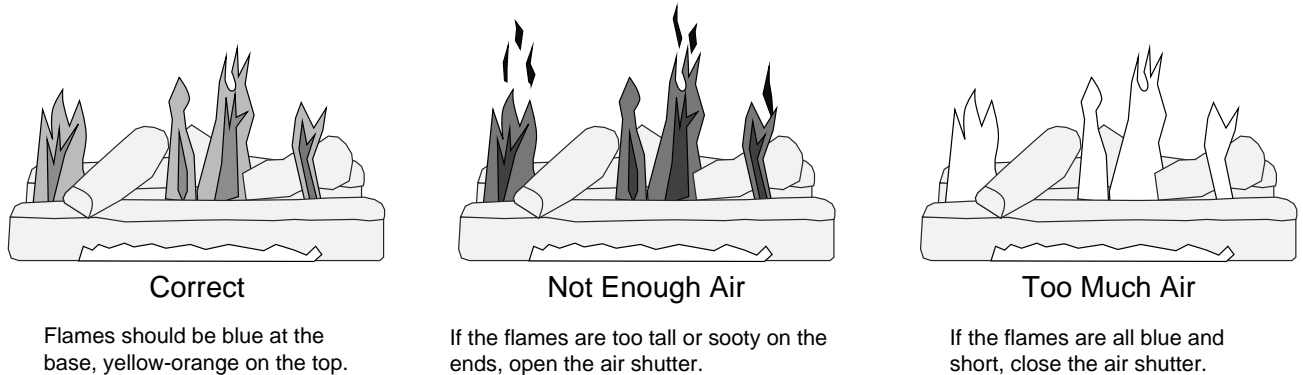

Air Shutter Adjustment

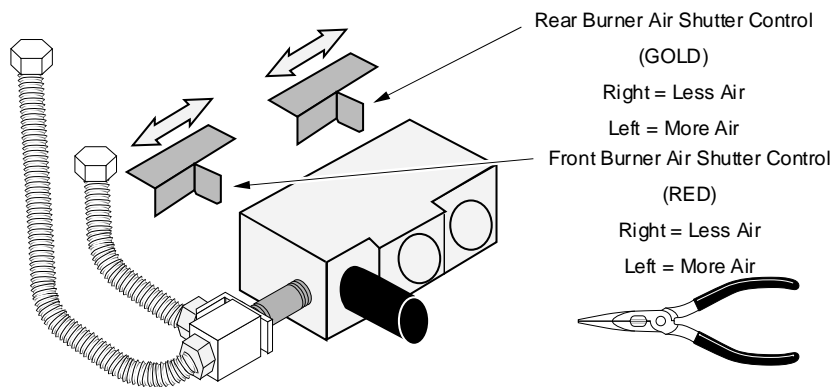

NOTE: you may wish to use pliers to adjust the front air shutter. Typically, the front air shutter is fully closed on NG, fully open on LP

10. Turn the flame adjust knob to its highest position - the flames should not contact the top of the firebox. Check the flame on low position. The flames should burn off of each burner hole. If the heater does not work correctly, contact your Travis dealer for a remedy.
11. Give this manual to the home owner for future reference and fully explain operation of this heater. For comprehensive operating and maintenance instructions, refer to the Owner's Manual.

ACID WASH WARNING: Before installing the faceplate, make sure any masonry that has been treated with acid wash has been properly neutralized (this is used primarily with brick faces). Acid wash (muriatic acid) is used to remove excess mortar. If not properly neutralized with an ammonia solution, the plated face may develop a permanent tarnish when the acid evaporates over time. Contact your dealer if uncertain your facing has been properly neutralized.

Barrier Removal



A barrier designed to reduce the risk of burns from the hot viewing glass is provided with this appliance and shall be installed for the protection of children and other at-risk individuals.



If the barrier becomes damaged, the barrier shall be replaced with the manufacturer's barrier for this appliance.



If using a face or grill that requires use of a cove cover, use the cove cover included with the fireplace (see below). Do not use the cover included with face or grill (if applicable).

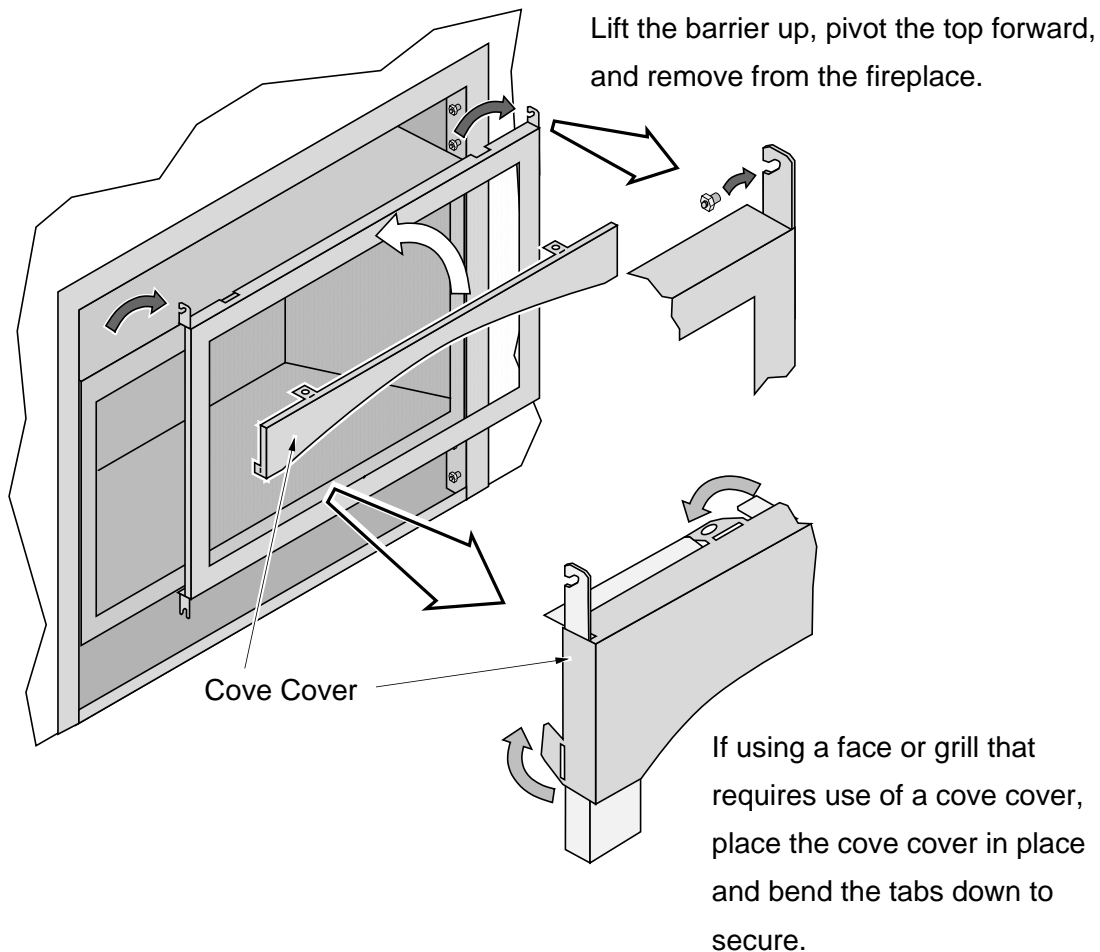

HINT FOR REPLACING THE BARRIER: Hold the barrier at an angle and insert the bottom slots first. Then pivot the barrier forward to engage the top hooks.

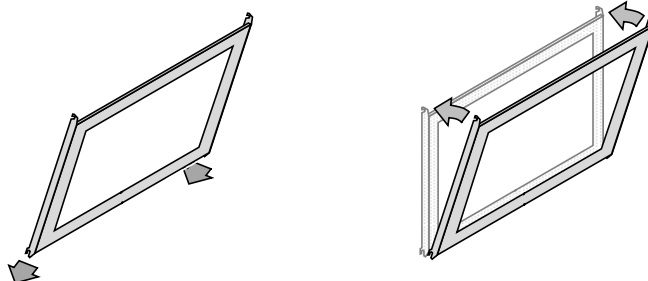

50 Finalizing the Installation (for qualified installers only)

Glass Frame Removal and Installation

Warning: The appliance must be completely cool before removing the glass.

Warning: Do not strike or slam the glass.

Note: Remove the barrier before removing the glass (see previous page). Replace barrier after replacing the glass.

- a** Based upon the face being used, either:
- swing the access door down and remove the top grill,
 - remove the face (unscrew or lift off - see the instructions included with the face for details).

Open the six latches holding the glass frame in place (start with the bottom three) - follow the directions shown to the right.

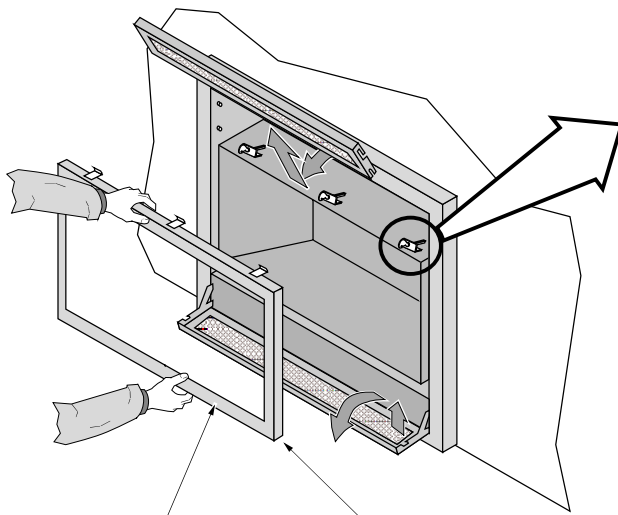

- b** Lift the glass frame up and pull it forward to remove.

NOTE:
You may need to lift the glass frame while re-attaching.

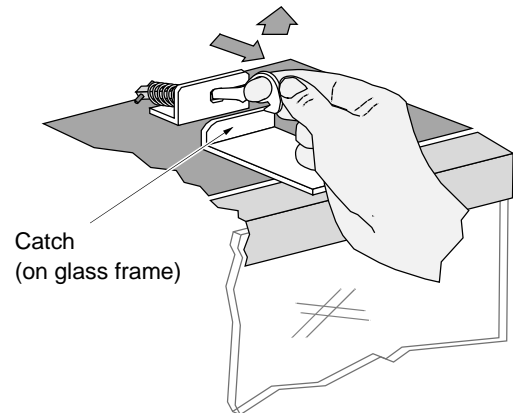
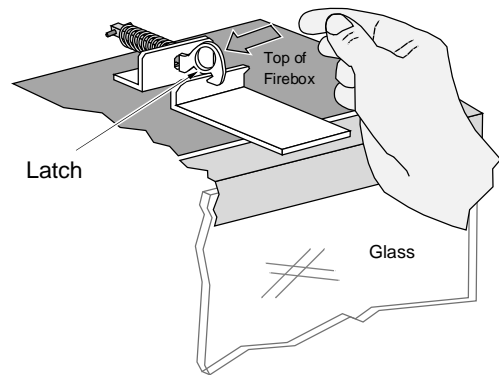

Re-Attaching the Glass Frame:

- Hang the glass frame on the firebox.
- While holding in place, attach the upper latches (follow the instructions above in reverse).
- Lift the glass frame slightly and attach the lower latches.

NOTE: Make sure the glass frame is all the way in place.

Glass Frame Removal and Installation (continued)

The latch can come loose from glass frame anchor. This occurs when it is turned 1/4 turn when it is disengaged. Follow the directions below to re-install the latch if it becomes loose.

Hold the latch at an angle and insert it into the slot on the glass frame anchor.

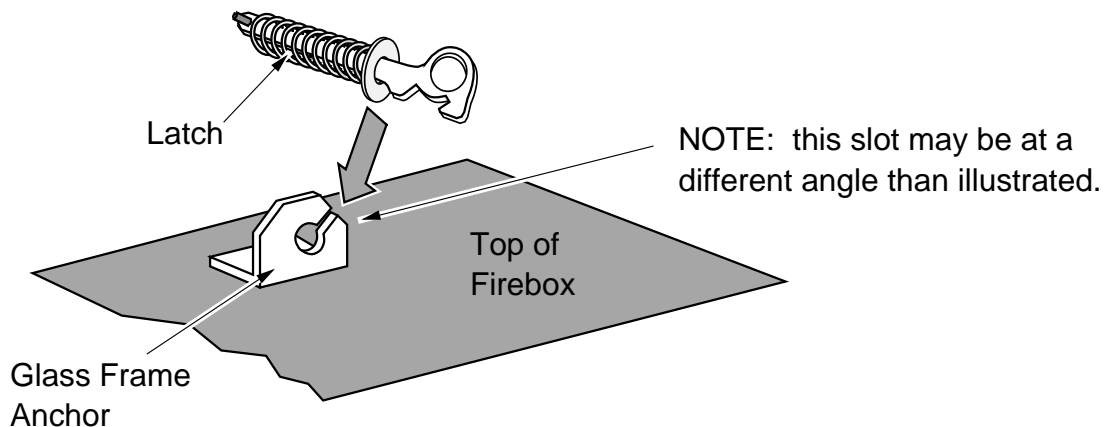

Note how the washer on the latch fits behind the flange on the glass frame anchor.

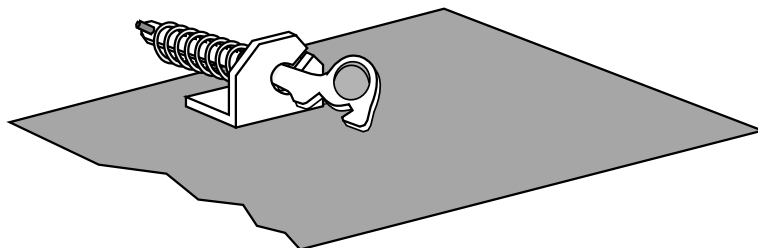

Once fully inserted, turn the latch until it is upright.

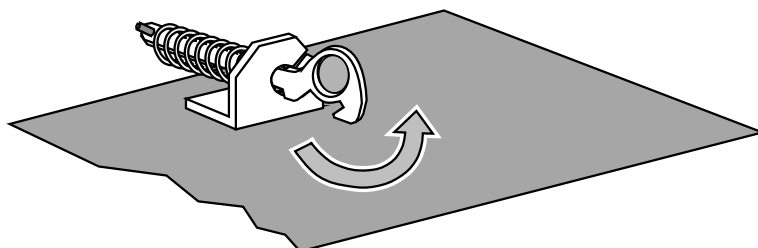

52 Finalizing the Installation (for qualified installers only)

Log Set Installation

Log Set Overview

When installed, the ten (10) logs should appear as shown below. The directions on the following pages detail installation of this log set.

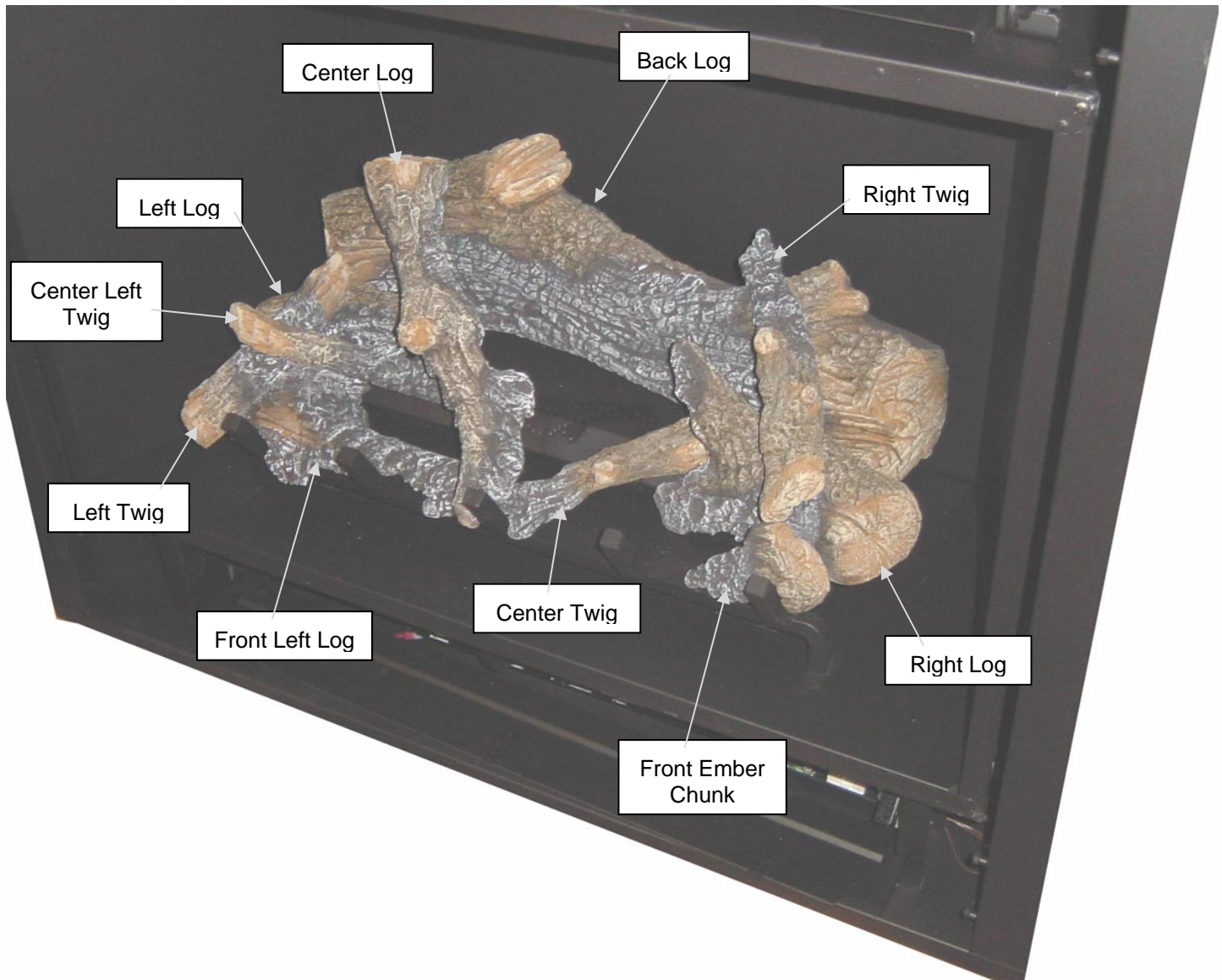

Back Log

The back log has two pockets that insert over two tabs on the back burner (see photos below). Place the log in place and push it back. The log straddles the burner and does not cover any burner holes.



Right Log

The right log has a channel on the bottom that fits over the grate. Place the log in place and slide it to the rear.



54 Finalizing the Installation (for qualified installers only)

Front Left Log

The front left log has a channel that fits over the grate. When in place the knob on the front of the log fits over the grate as well.



Left Log

The left log has a channel on the bottom. Place this channel over the grate. When in place, make sure the log is positioned so it does not block any burner holes.



Center Twig

The center twig is shown below. It has a pin on the bottom side. When in place, the fork on the front straddles the grate and the pin rests on the rear burner (make sure it is not over any burner holes).



Front Ember Chunk

The front ember chunk has a groove on the bottom that fits over the grate. Place it as shown below.

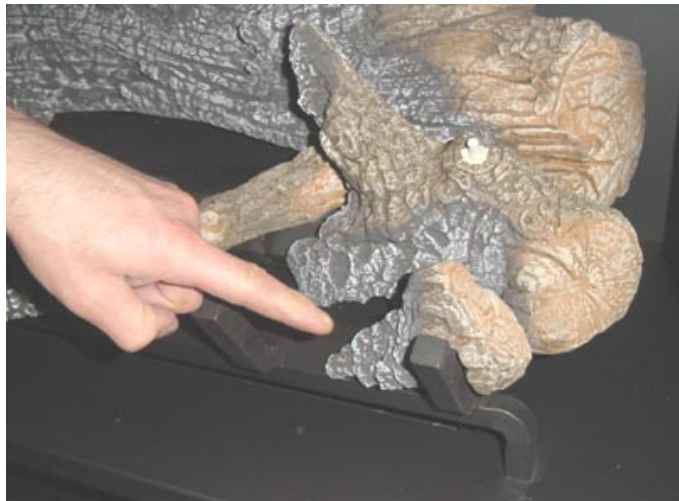

56 Finalizing the Installation (for qualified installers only)

Left Twig

The left twig has a hole on the bottom that fits over the pin on the front left log. Place the twig as shown below. The front left log has a groove that will point the twig upwards and to the right.



Center Left Twig

The left center twig is flat on the bottom and has a fork at one end. Place the twig as shown below. Note how the twig rests in the groove in the front left log and the fork lies directly on the bend in the rear burner. Make sure the twig is positioned so it does not cover any burner holes.



Center Log

The center log has a hole on the back and a fork on the front. Position the log so this fits over the pin on the back log. Make sure the fork on the front of the log fits over the grate as shown below.



Right Twig

The right twig has a hole on the bottom that fits over the pin on the right log. Position the twig so it rests on the back log as shown below.



58 Finalizing the Installation (for qualified installers only)

Ember Installation

A bag of embers is provided to further enhance the firebox. Place the embers on the firebox floor and on the burner. Do not place embers over any of the burner holes or air channels.



Rock Wool Placement

The included rock wool is placed on top of the burner to enhance the glow from the burner. **The rock wool works best when it is applied in a very thin, porous layer.** The best method for applying the rock wool is to brush it on to the burner. Compress a clump of rockwool between your thumb and forefinger. Use a stiff brush to apply a thin layer of rockwool fibers onto the burner. Do not use the entire bag of rockwool. Use only a small amount and save the remainder. Over-use of rockwool will diminish the glow and may cause sooting or other adverse conditions.

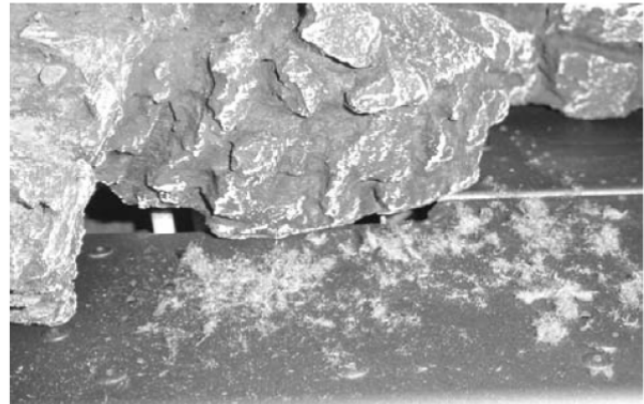

LP Conversion Instructions

Install the conversion kit prior to installing the gas line to ensure proper gas use.

- 1 Remove the glass (see page 49). Remove the logs and embers (if installed - page 52)
- 2 Remove the burners following the directions below.

Lift the rear burner, slide it to the right, and lift it from the firebox. The burner has a bracket that inserts over two pins behind the burner. When replacing the burner make sure it is properly located.



Lift the front burner, slide it to the right, and lift it from the firebox. When replacing the burner make sure it is properly located.



Remove the manifold cover and place it aside.



60 Finalizing the Installation (for qualified installers only)

3 Follow the directions below to replace the orifice.

(a) Slide the air shutters to provide access to the orifices.

(b) Remove and discard the two gaskets on the front burner orifice.

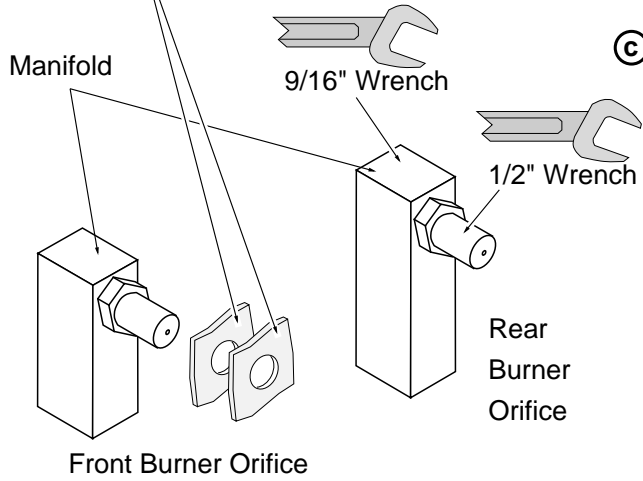

(c) Use a 9/16" wrench to secure the manifold while removing each orifice with a 1/2" wrench.

(d)

Apply thread sealant to the LP orifices prior to installation. Use the chart below to identify the correct orifices.

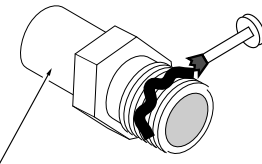

Look here for the orifice identification

(e)

Screw each LP orifice until orifice protrudes 15/16" (23.8mm) indicating full insertion (use wrench to secure manifold when re-attaching orifice).

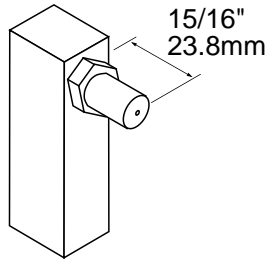

	NG	LP
Front	#49	#56
Rear	#49	#57

- 4 Install the LP pilot orifice following the instructions below.
 - (a) Use a 7/16" open-end wrench to remove the pilot hood.
 - (b) Remove and discard the Natural Gas (NG) orifice. Place the LP orifice in the pilot assembly then replace the pilot hood, tightening the pilot hood until it is snug (do not over-tighten).

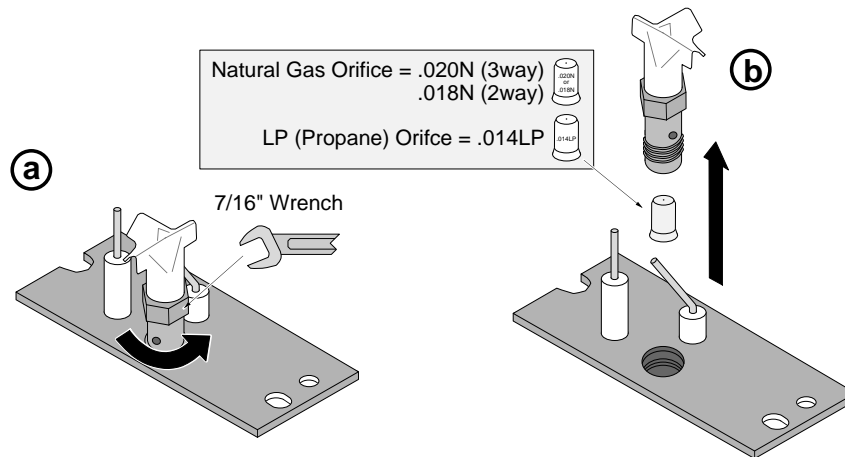

- 5 Re-install the manifold cover (see photo below). Replace the firebox components. Install the logs and embers. Replace the glass.



- 6 Remove and discard the screws (see "a" below) holding the stock regulator in place (see "b" below). Remove the stock regulator and gasket (see "c" below). Place the LP regulator in place, making sure the pre-fitted gasket (see "c" below) is in place. NOTE: There is a label on the base of the regulator knob indicating regulator type (NG or LP). Secure the regulator with the screws included with the regulator – tighten to 25 lb-in of torque (2.82 NM). Place the included label on the valve body where it can be easily seen to insure proper identification. **NOTE: Leak test this area after the heater is installed, gas is connected, and the main burner is lit.**

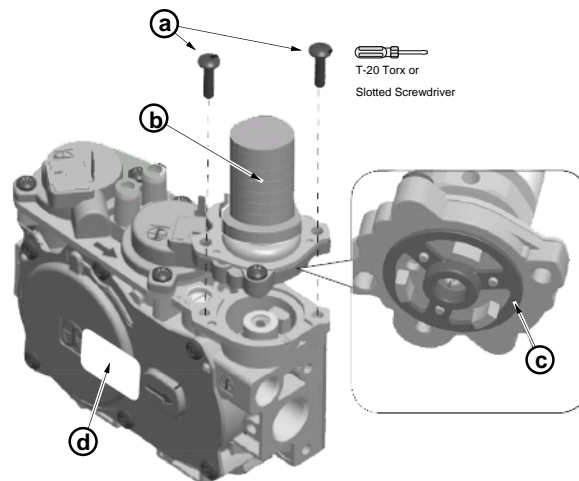

- 7 Make the gas line connection, bleed the gas line (if applicable), start the heater and thoroughly leak-test all gas connections and the gas control valve.

Fireback Installation

WARNING: Turn off gas to the appliance and make sure it has fully cooled prior to conducting service.

- 1 Remove the glass frame and logs.
- 2 Install the firebacks following the directions to the right (note: the hearth plate is discarded).

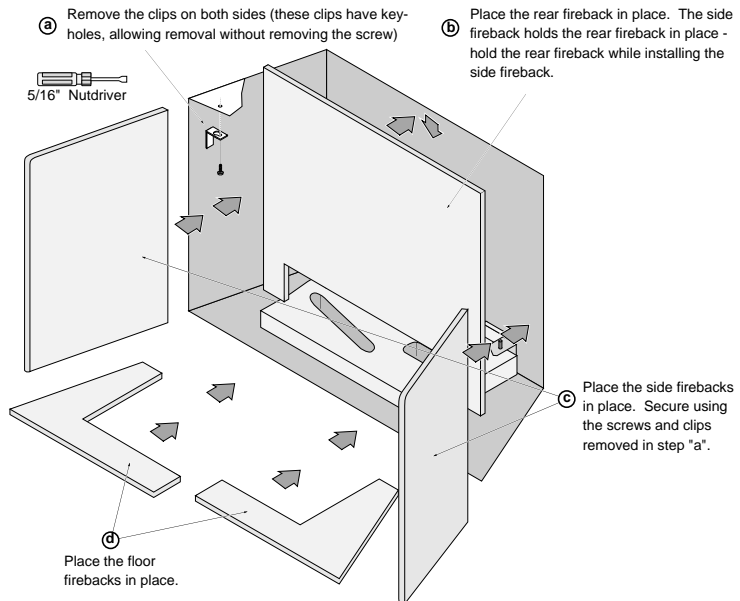
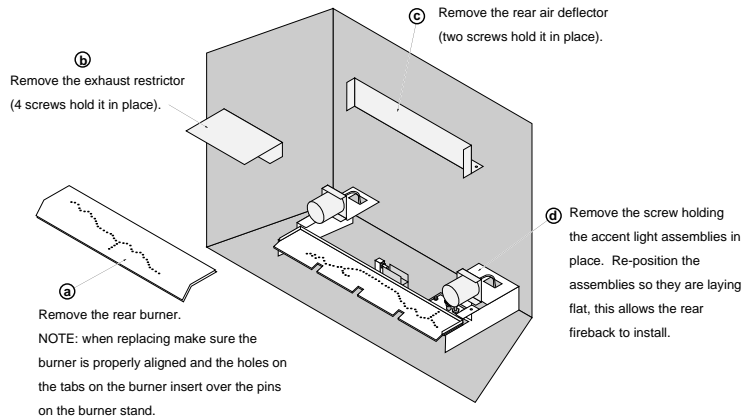
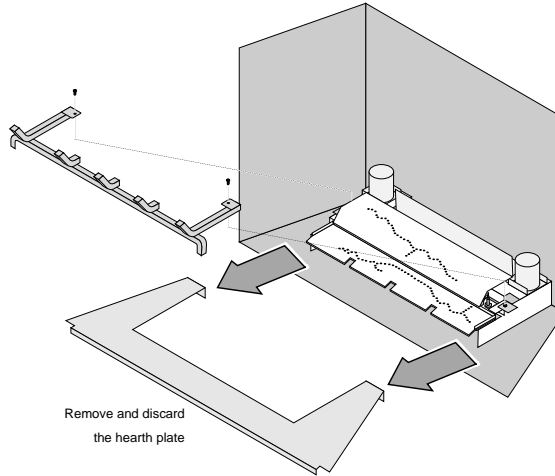

Grill Installation

Certain faces allow for installation of an upper and lower grill. Follow the directions below to install.

Upper Grill Installation (FPX and Avalon)

Hold the grill at an angle and insert the lower slot over the lower bushing on the fireplace (both sides). The grill fits inside the tabs for the barrier screen.

Swing the grill upwards to engage the upper slot. You will need to lift the grill slightly to get it over the bushing. Once in place the grill is held in place by gravity.

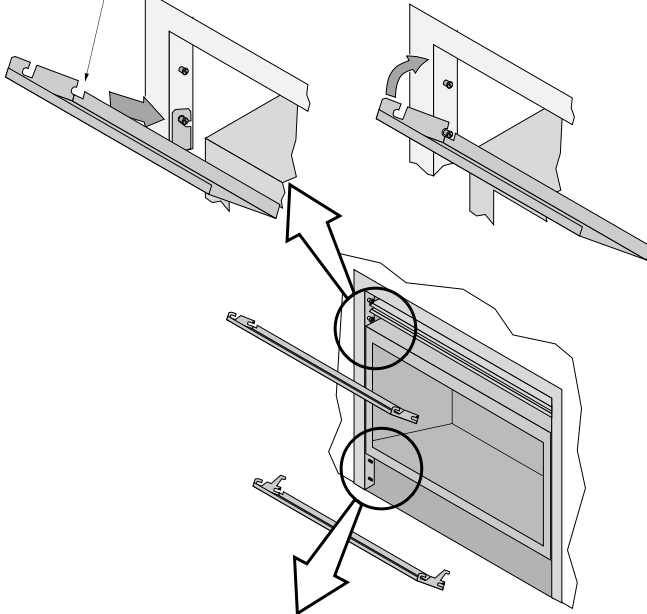

Lower Grill Installation

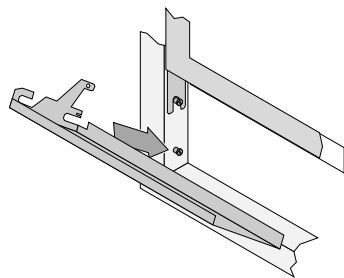

Hold the grill at an angle and insert the lower slot over the bushing on the fireplace (both sides). You may need to press on the grill to get the tab over the bushing (this prevents the grill from accidentally falling off).

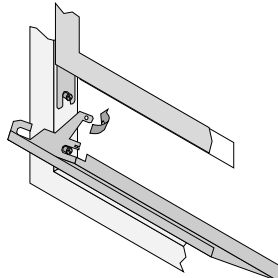

Bend the tab outward on both sides. This is the end-stop for the lower grill, it allows the grill to swing forward.

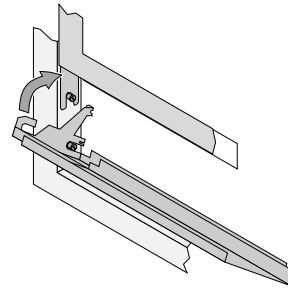

Swing the grill upwards to engage the upper slot. The grill fits inside the tabs for the barrier screen. You will need to lift the grill slightly to get it over the bushing. Once in place the grill is held in place by gravity.

Upper Grill Installation (Lopi)

NOTE: The upper grill is difficult to install the first time - be patient, after you install it, you will know how it installs and it will be much easier the second time.

SIDE VIEW

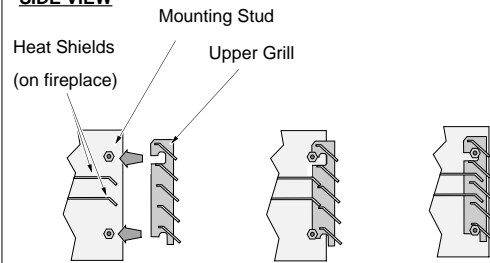

Position the grill so the slots on the grill align with the mounting studs.

You may need to push in and upwards on the grill as it inserts.

The grill, when fully inserted, will slide down and "click" into place.

GS2 Remote Installation

Packing List

- Transmitter
- Battery Box
- Remote Wall Mount with Attachment Screws and Anchors
- Stepper Motor
- Torx Wrench
- Remote Control DVD
- GSR2 IFC
- Splitflow Harness (attached to IFC)
- System Jumper (attached to IFC)
- Battery Box Harness (attached to IFC)
- Fan/Light Harness (attached to IFC)
- (2) Jumper Wires
- (2) 4" Cable Ties

Warnings



Turn off power to the heater (unplug or turn off at the breaker).



Shut off gas at the appliance (or at meter).

HINT:

If using a blower, make sure to have it on hand while installing the remote.

Remote Control / Pilot Warnings



Installing batteries in the battery holder or connecting the appliance to power may automatically initiate the CPI pilot mode, resulting in a lit pilot flame. Do not place combustibles in the firebox.

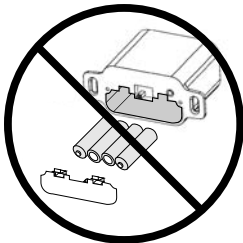

KEEP BATTERIES AND COVER INSTALLED AT ALL TIMES

The remote control system requires the batteries and battery cover to remain in place at all times. Once the batteries or cover are removed, the system may re-start in standing pilot mode. If this occurs when the heater is in Remote Mode, you will not be able to turn the heater off manually from the battery box.

If you need to replace dead batteries, make sure to **turn the appliance off** before removing the batteries.

NOTE: If the batteries go dead, the system will operate normally as long as household power (120v AC) is present.

Base Wiring Diagram

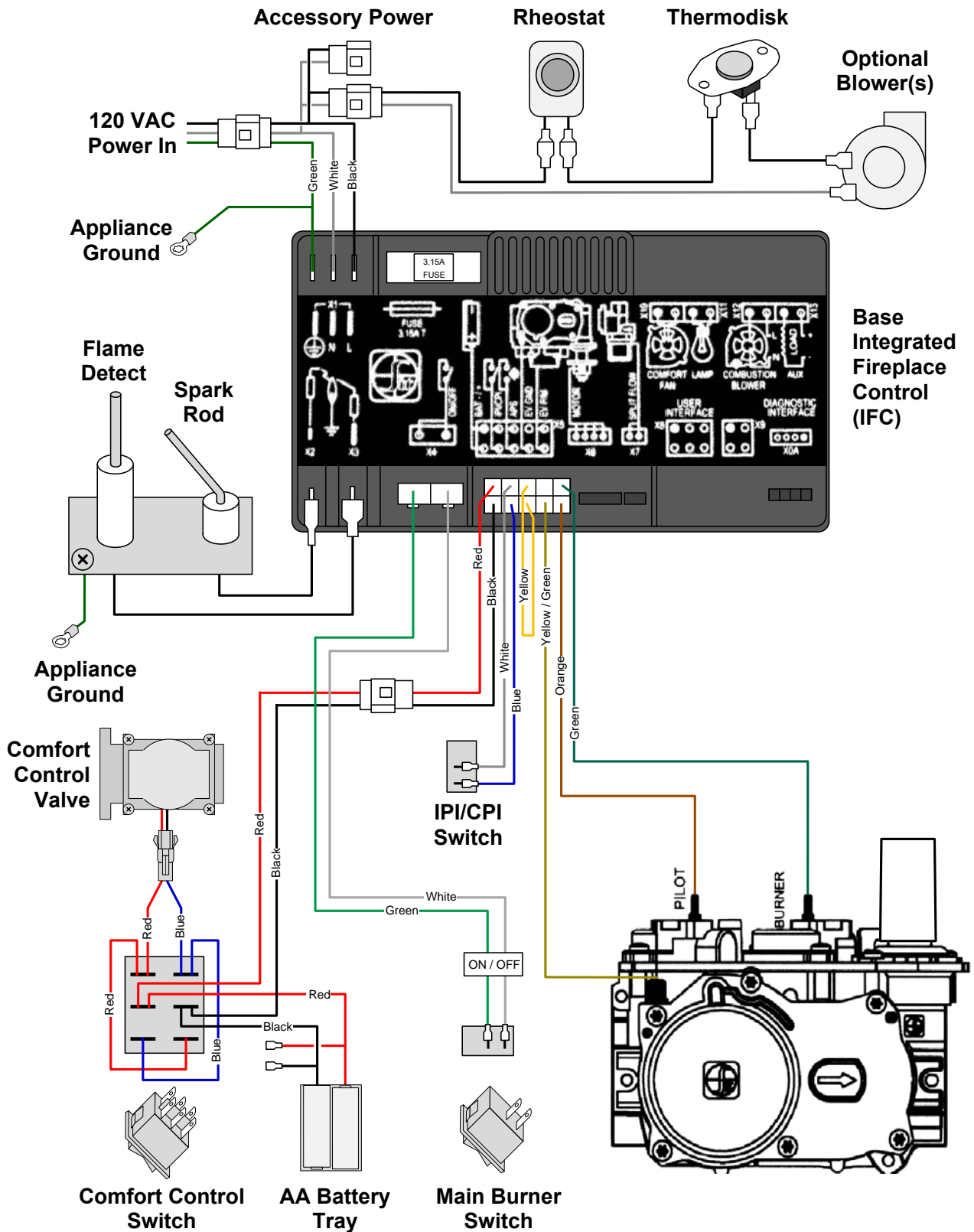

GS2 Remote Wiring Diagram

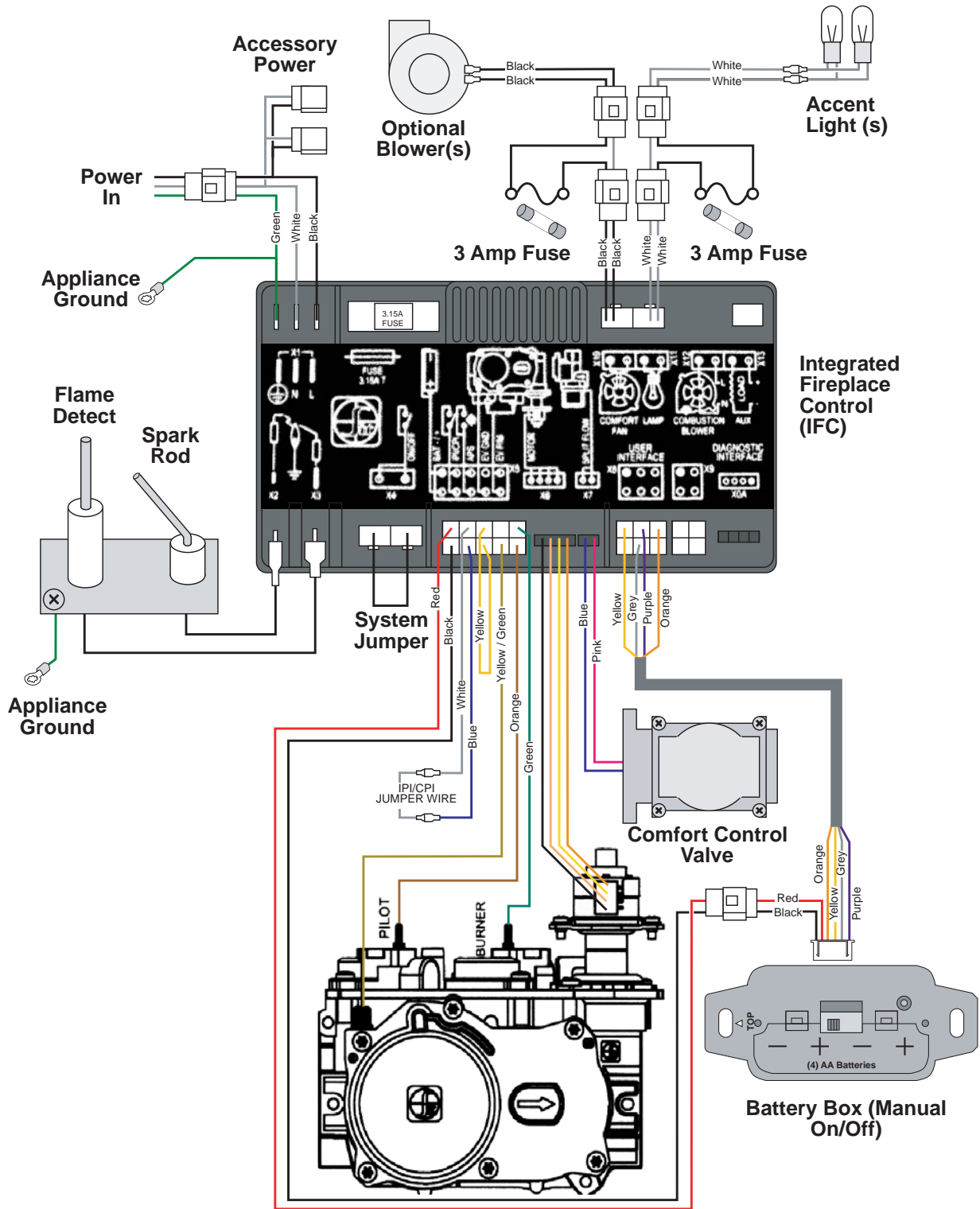

Installation

1. Remove the concealment cover from the heater and set aside.



2. Remove the On/Off-Comfort Control-Battery Plate from the control panel (keep the screws).

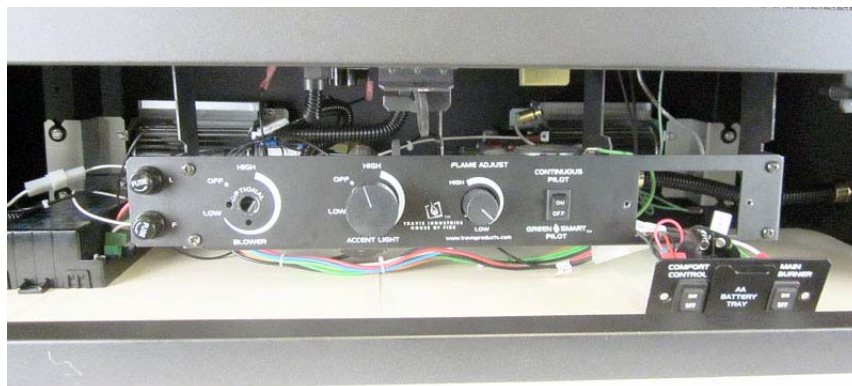

3. Remove the control panel and place face-down in front of the heater (keep the screws).

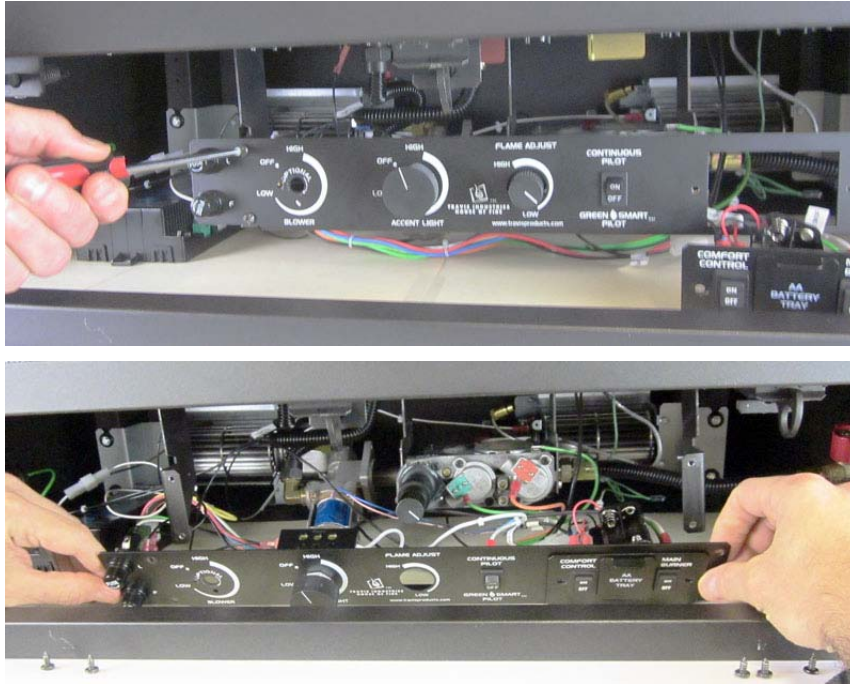

4. Disconnect input power.

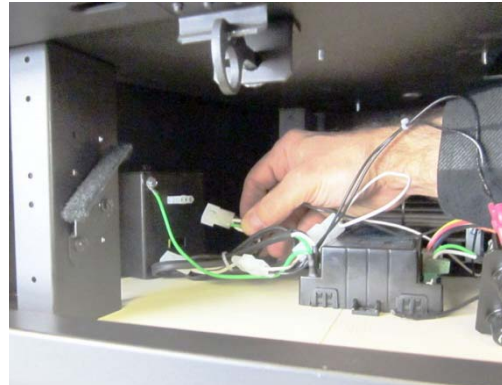
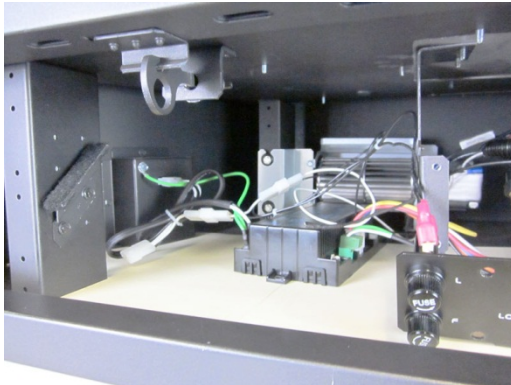

5. Disconnect the ground wire.

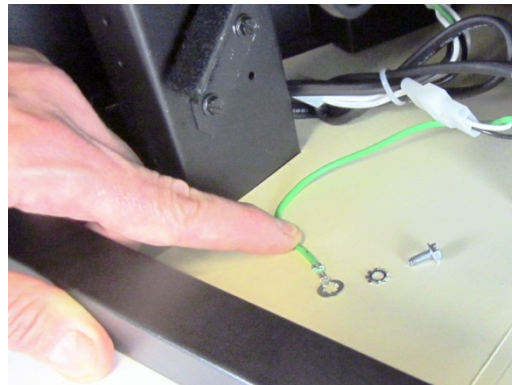
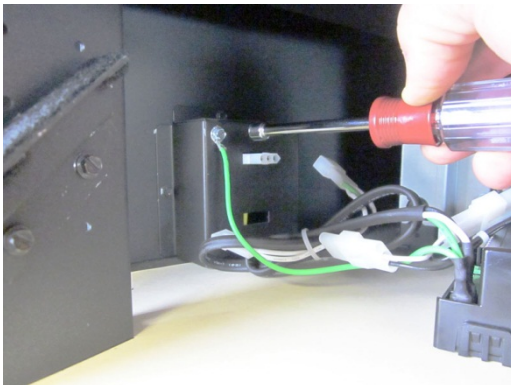

6. Pull the base IFC forward to access the wiring (it is held in place with Velcro).

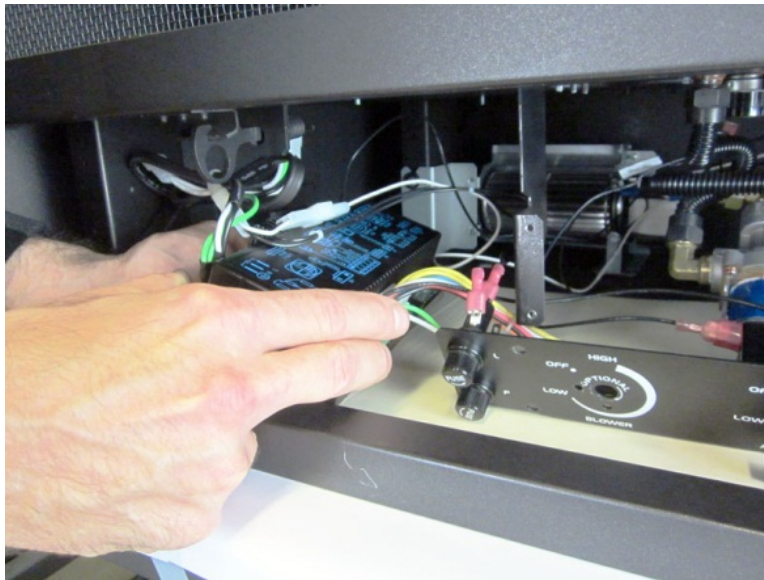

7. Disconnect the comfort control wires and battery backup wires from the battery holder.

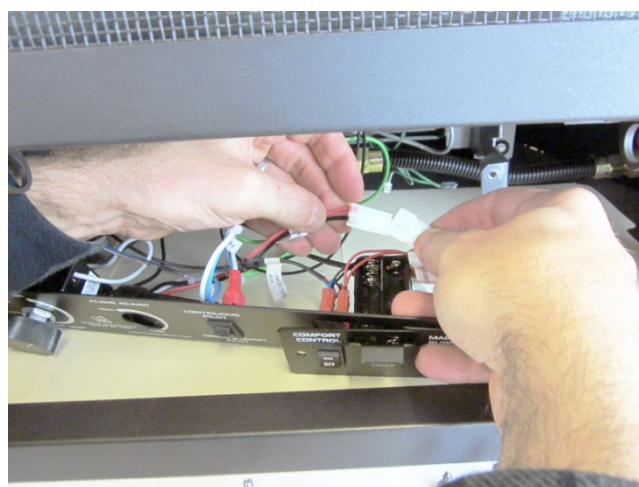
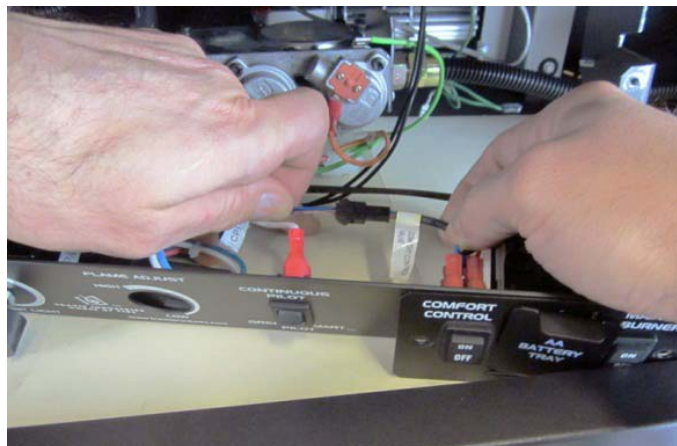

8. Disconnect the following:

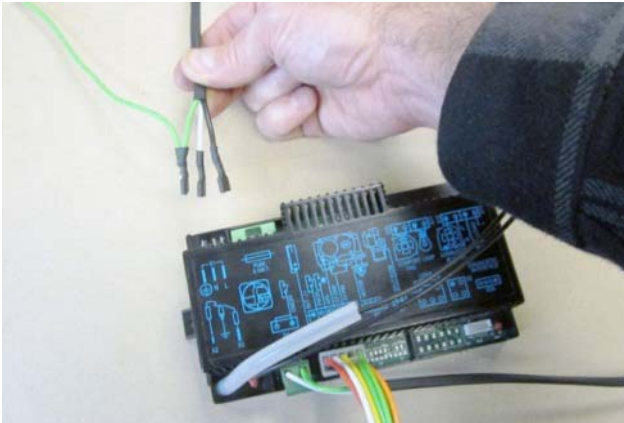

Power (3 wires)

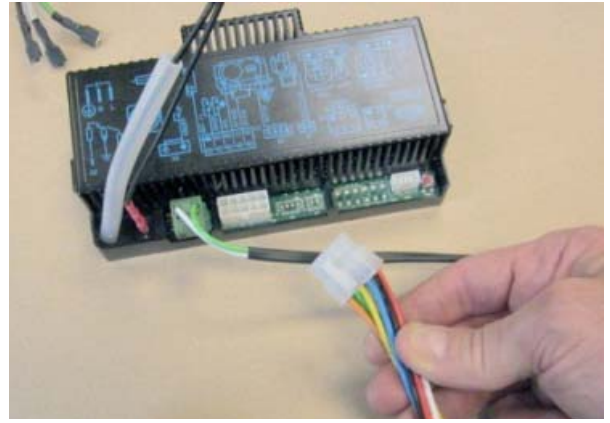

Main harness

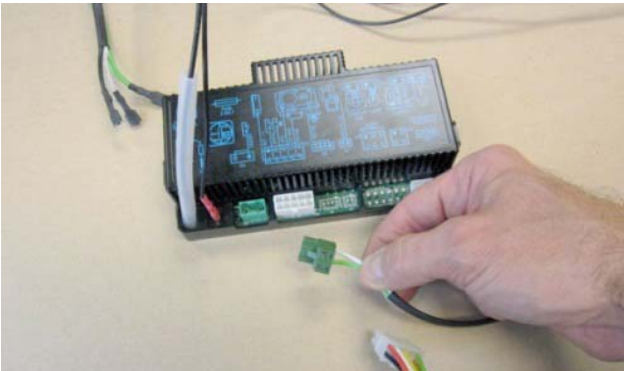

On/Off wires

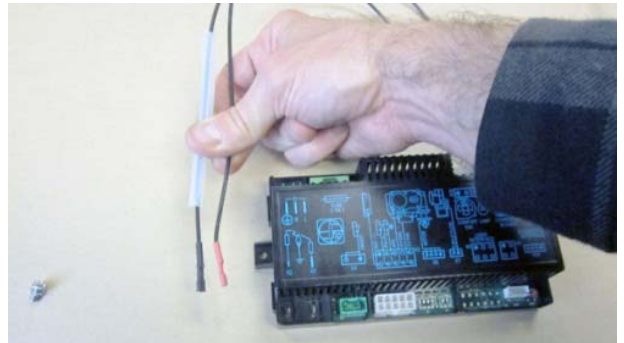

Pilot connections (slide silicone tubing up)

9. Remove and place aside the base IFC (it may be kept for spare parts).
10. Remove and place aside the On/Off-Comfort Control-Battery Plate with harness (the batteries and assembly may be kept for spare parts).
11. Remove and discard the screws (see "a" below) holding the stock regulator in place (see "b" below). Remove and discard the stock regulator, spring, and gasket (see "c" below).

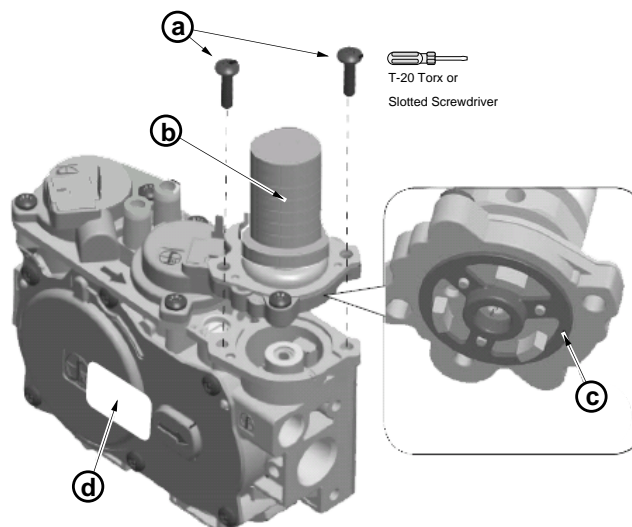

12. The stepper motor (adjustable regulator) has an installation sheet included with it – make sure to follow all of the directions. Place the stepper motor on the gas control valve (see below) – **MAKE SURE IT IS CORRECTLY ORIENTED.** Secure using the screws included with the motor – tighten to 25 Lb-inches. Leak-test this area after installation to verify proper installation. Route the stepper motor wire near the IFC location.

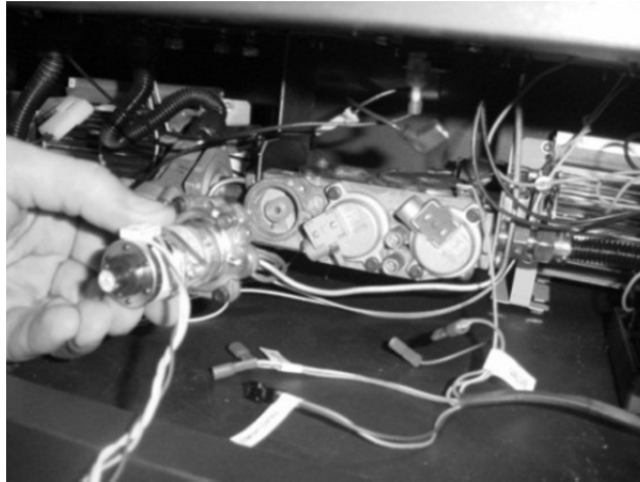

Instructions for Using the Optional Blower with GS2 Remote

When using the Greensmart™ 2 remote, the power for the blower will be routed through the fuse and IFC, bypassing the rheostat and snap disc included with the blower kit.

Order of Installation

Install the blower assemblies with the IFC removed (see instructions included with the blower for details). Connect the wiring as shown below, attaching the power input to the IFC after the IFC is placed in location (see “e” below).

Wiring the Blower to the GSR2 IFC (Bypassing the Rheostat and Snap Disc)

Disconnect the blower power input (see “a” below). Connect the blower wiring harness to the fuse output (see “b” below). Disconnect and discard the electrical line intended to connect the snap disk to the rheostat (carefully remove the wire tie from the wiring harness – see “c”). Attach the jumper wire (included with the remote) to the wires labeled “SNAP DISC” (see “d” below). Attach the blower power input (see “e”) to “FAN” lead on the fuse harness (pre-connected to the IFC). This circuit bypasses the rheostat and snap disc (these components included with the blower kit are not used and may be kept for replacement part purposes).

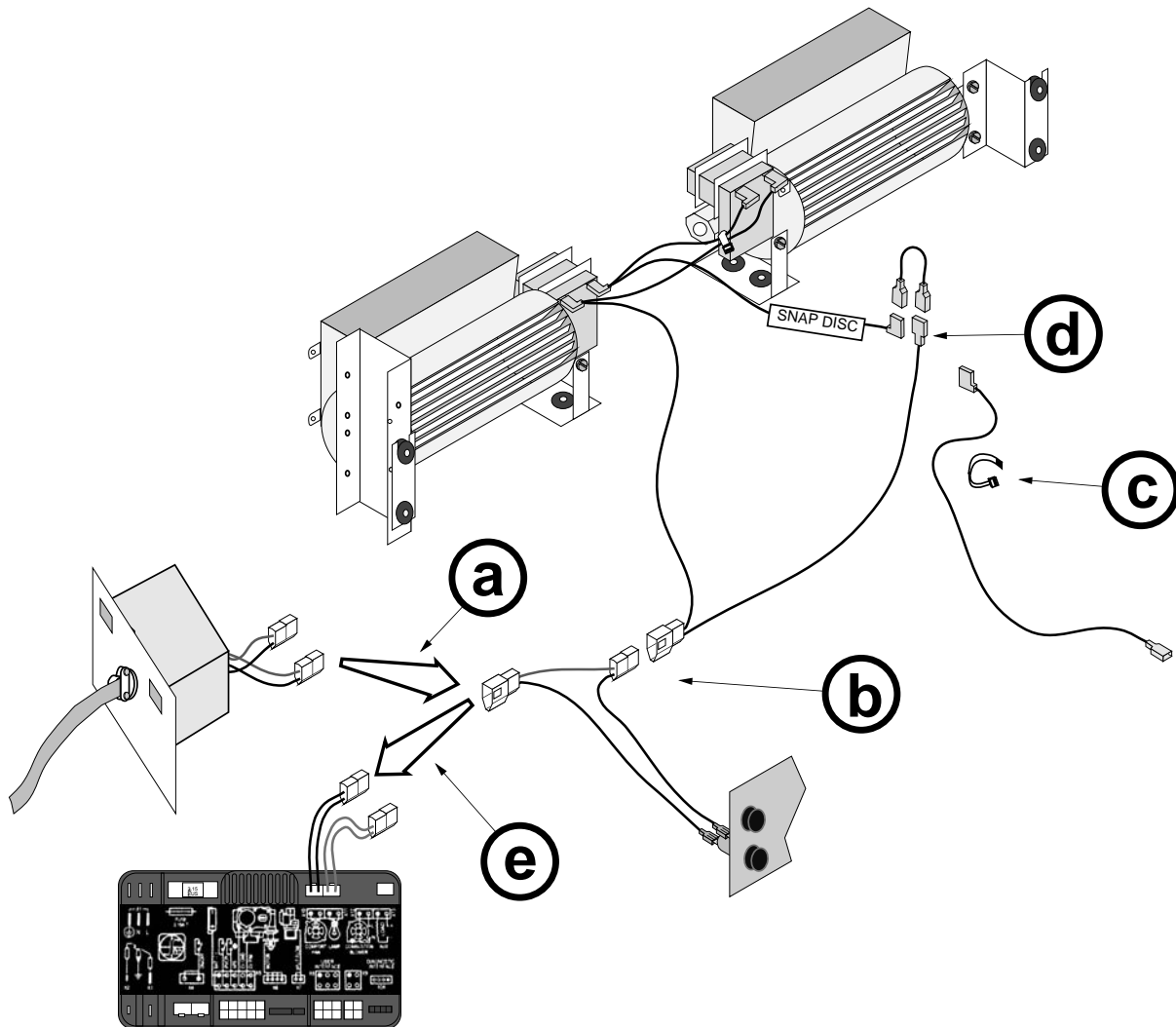

13. Wire the accent light for remote operation.

When using the Greensmart™ 2 remote, the power for the accent light(s) will be routed through the fuse and IFC, bypassing the rheostat.

Order of Installation

Connect the wiring with the IFC removed as shown below. Attach the power input to the IFC after the IFC is placed in location (see “a” below).

Wiring the Blower to the GSR2 IFC (Bypassing the Rheostat)

Disconnect the accent light power input (see “a” below). Disconnect the two wires leading to the rheostat and attach them together (see “b” below). Remove the rheostat from the control panel (see “c” below). Attach the accent light power input (see “d”) to “LIGHT” lead on the fuse harness (pre-connected to the IFC). This circuit bypasses the rheostat (this component is not used and may be kept for replacement part purposes).

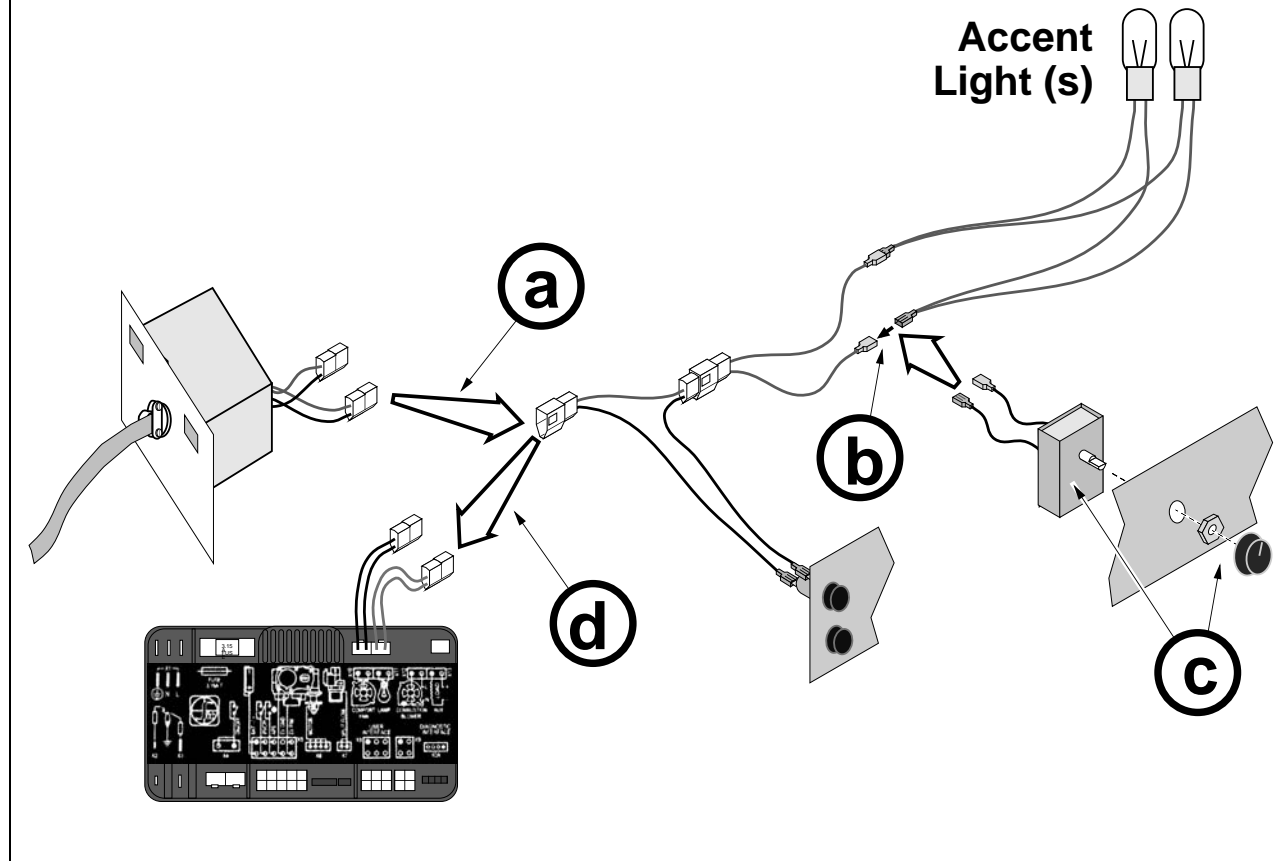

14. Place the GSR2 IFC near the appliance.

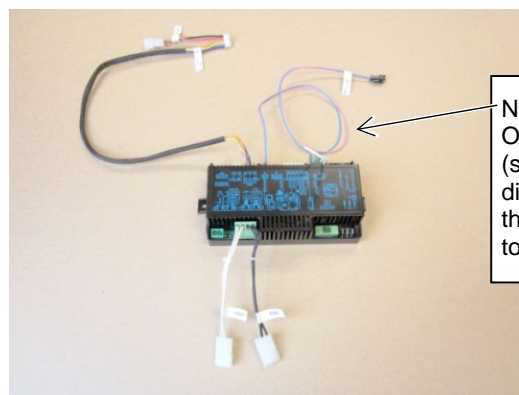

NOTE:
On newer units the comfort control (splitflow) jumper is removed and discarded. It is not needed because the splitflow wire connects directly to the IFC.

15. Attach the following:

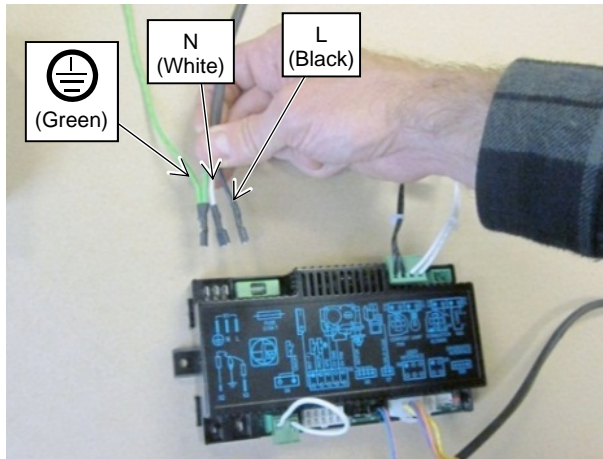

Power (3 wires – make sure orientation is correct)

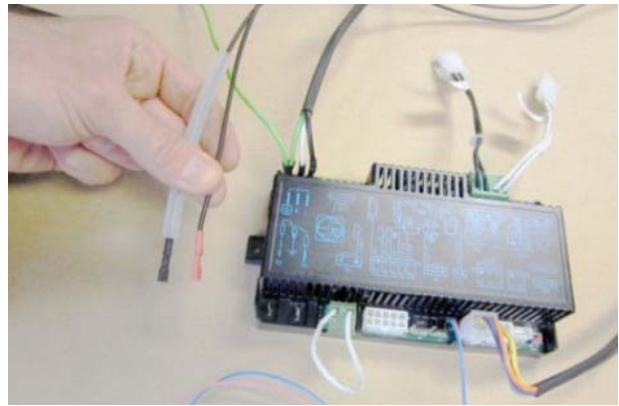

Pilot connections

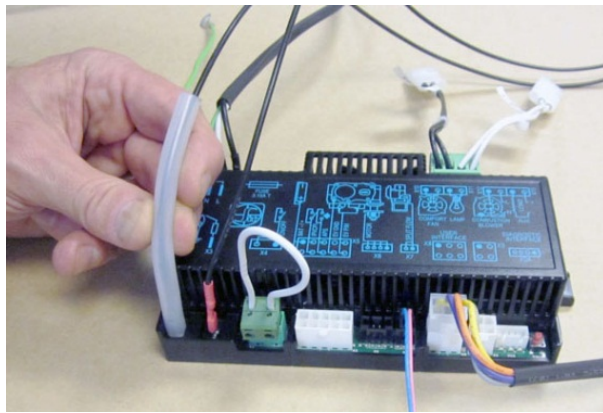

Make sure silicone tubing is pushed down

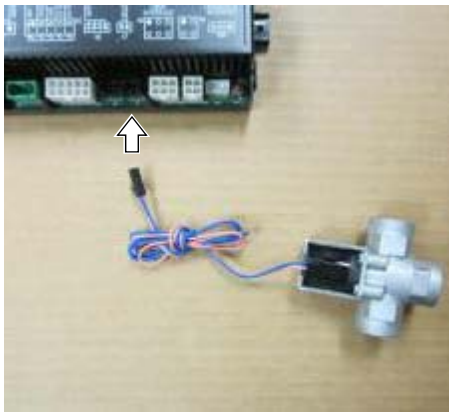

Comfort Control connection

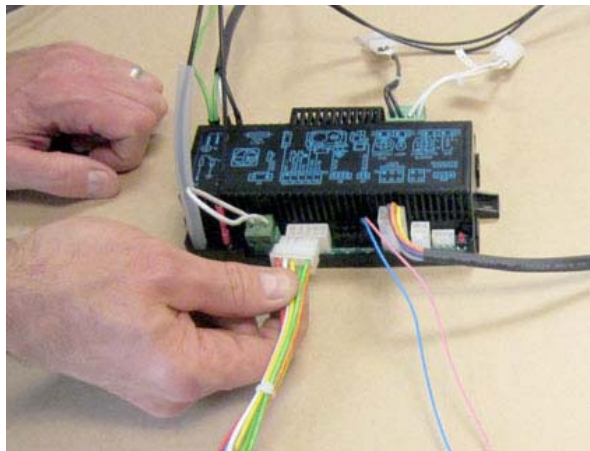

Main Harness

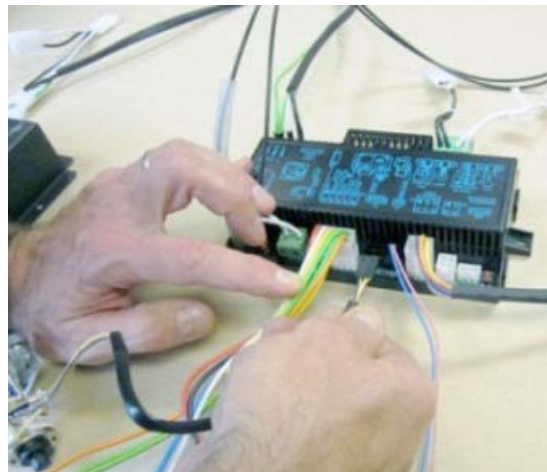

Stepper Motor

16. Disconnect the IPI/CP switch from IPI/CP wires. Attach one of the jumper wires to the two wires.

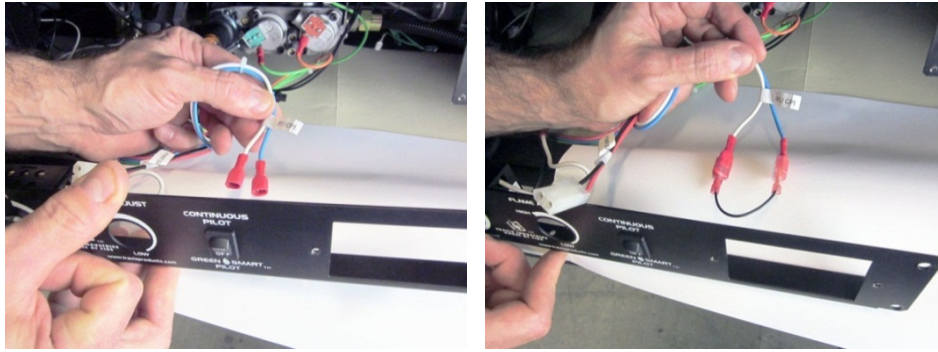

17. Remove the IPI/CPI switch and place aside (may be kept for spare parts).



18. Connect the accent light wires to the GSR2 IFC.

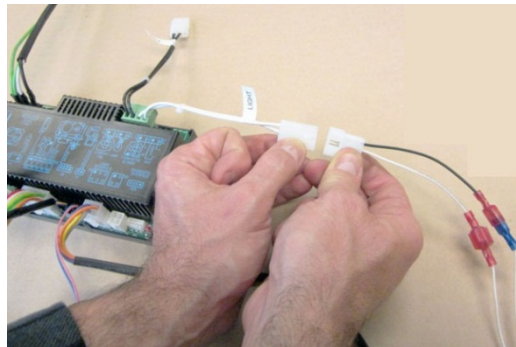

NOTE: If using a blower, connect the power input to the GSR2 IFC.

19. Connect the battery box power molex connector to the main harness molex connector.

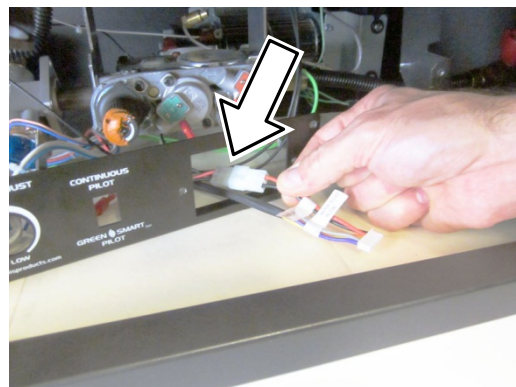

76

Optional Equipment (for qualified installers only)

20. Route the battery box harness through the control panel and attach to the battery box.

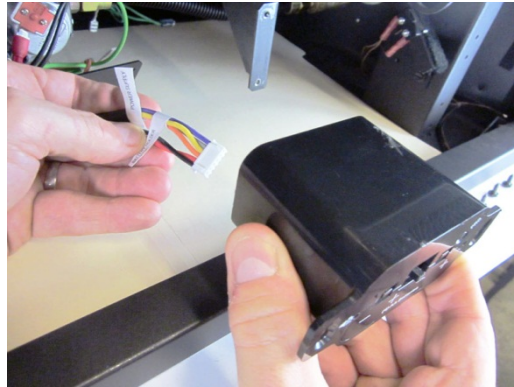
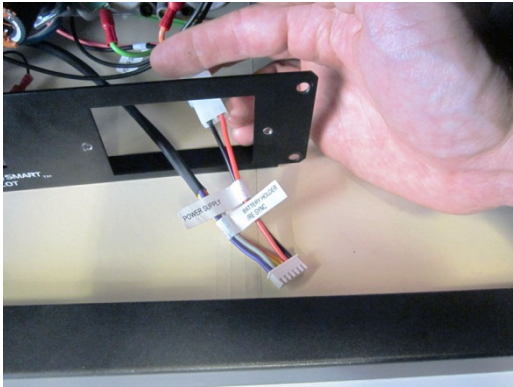

21. Place the IFC in location inside the heater and attach using the applied velcro tape.

22. Re-connect the ground wire.

23. Use the two included cable ties to make sure all wiring is secure and does not contact any hot or moving parts.

24. Attach the control panel.

25. Attach the battery box to the control panel using the screws removed in step 2.

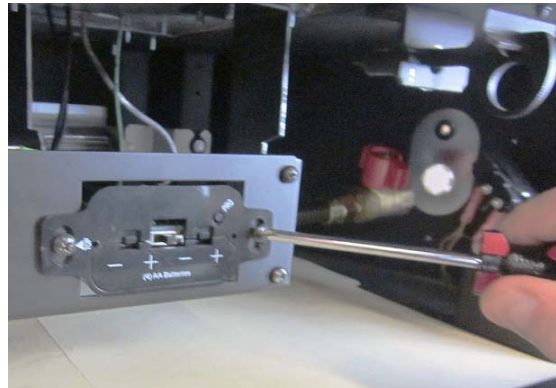

26. Re-connect the input power input.

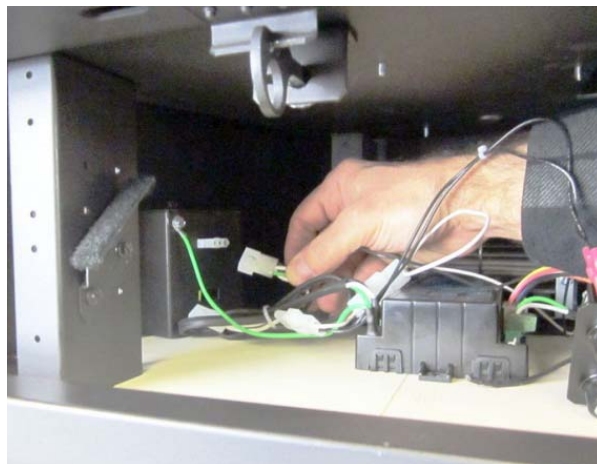

27. Restore the fireplace to the correct configuration (turn power and gas on).

See the instructions included with the remote for synchronizing the remote and operating instructions.

Index

Additional Items Required	7	LP Conversion Instructions	59
Approved Vent Configurations	27	Mantel Requirements	44
Barrier Removal	49	Optional Wall Switch or Thermostat Installation	24
Dimensions	6	Rear Vent Configuration with Horizontal Termination (no vertical rise)	30
Electrical Connection	23	Rear Vent Configuration with Horizontal Termination (with vertical rise)	31
Facing Requirements	37	Rear Vent Configuration with Vertical Termination	32
Fireback Installation	62	Recommended Installation Procedure	7
Fireplace Placement Requirements	11	Rock Wool Placement	58
Gas Line Requirements	21	Safety Warnings	4
Glass Frame Removal and Installation	50	Steps for Finalizing the Installation	47
Grill Installation	63	Termination Requirements	35
GS2 Remote Installation	64	Top Vent Configuration with Horizontal Termination	33
Hearth Requirements	36	Top Vent Configuration with Vertical Termination	34
Heating Specifications	6	Top Vent or Rear Vent Configuration	9
Installation Example - Build-In with Horizontal Termination	46	Vent Requirements	25
Installation Example - Build-Out (Dog-House) with Hor. Termination	45		
Installation Options	6		
Installation Overview	7		
Log Set Installation	52		