

- Direct Vent Freestanding Stove
- Natural Gas or Propane
- Vent Horizontally or Vertically
- Standard Residential
- Mobile Home Approved

Tested and Listed by



Omni-Test Laboratories, Inc.  
Beaverton, Oregon  
Report # 028 – S – 43 - 5  
ANSIZ21.88

Featuring the  Burner

**WARNING:** If the information in this manual is not followed exactly, a fire or explosion may result causing property damage, personal injury or loss of life.

- Do not store or use gasoline or other flammable vapors and liquids in the vicinity of this or any other appliance.
- **WHAT TO DO IF YOU SMELL GAS**
  - Do not try to light any appliance.
  - Do not touch any electrical switch; do not use any phone in your building.
  - Immediately call gas supplier from a neighbor's phone. Follow the gas supplier's instructions.
  - If you cannot reach your gas supplier, call the fire department.
- Installation and service must be performed by a qualified installer, service agency or the gas supplier.

## Allegiance Owner's Manual



**Installer:** After installation give this manual to the home-owner and explain operation of this heater.

**TRAVIS INDUSTRIES  
HOUSE OF FIRE**  
4800 Harbour Pointe Blvd. SW  
Mukilteo, WA 98275

© Copyright 2005, T.I.      \$10.00      93508123      4041220

## ***Introduction***

---

We welcome you as a new owner of an Allegiance Stove. In purchasing this heater you have joined the growing ranks of concerned individuals whose selection of an energy system reflects both a concern for the environment and aesthetics. The Allegiance is one of the finest home heaters the world over. This manual will explain the installation, operation, and maintenance of this gas-burning heater. Please familiarize yourself with the Owner's Manual before operating your heater and save the manual for future reference. Included are helpful hints and suggestions which will make the installation and operation of your new heater an easier and more enjoyable experience. We offer our continual support and guidance to help you achieve the maximum benefit and enjoyment from your heater.

## ***Important Information***

---

No other Allegiance has the same serial number as yours. It can be found on the back of the heater.

This serial number will be needed in case you require service of any type.

Model: \_\_\_\_\_ Allegiance EF \_\_\_\_\_

Serial Number: \_\_\_\_\_

Purchase Date: \_\_\_\_\_

Purchased From: \_\_\_\_\_

\_\_\_\_\_  
\_\_\_\_\_

### **Mail your Warranty Card Today, and Save Your Bill of Sale.**

To receive full warranty coverage, you will need to show evidence of the date you purchased your heater. Do not mail your Bill of Sale to us.

We suggest that you attach your Bill of Sale to this page so that you will have all the information you need in one place should the need for service or information occur.

|   |   |
|---|---|
|  | We suggest that our gas hearth products be installed and serviced by professionals who are certified in the U.S. by the National Fireplace Institute® (NFI) as NFI Gas Specialists. |
|---|---|

# Safety Precautions

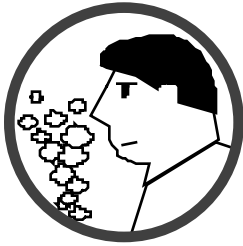

**IF YOU SMELL GAS:**

- \* Do not light any appliance
- \* Extinguish any open flame
- \* Do not touch any electrical switch or plug or unplug anything
- \* Open windows and vacate building
- \* Call gas supplier from neighbor's house, if not reached, call fire department



- This unit must be installed by a qualified installer to prevent the possibility of an explosion. Your dealer will know the requirements in your area and can inform you of those people considered qualified. The room heater should be inspected before use and at least annually by a qualified service person. More frequent cleaning may be required due to excessive lint from carpeting, bedding material, etc.
- The instructions in this manual must be strictly adhered to. Do not use makeshift methods or compromise in the installation. Improper installation will void the warranty and safety listing.

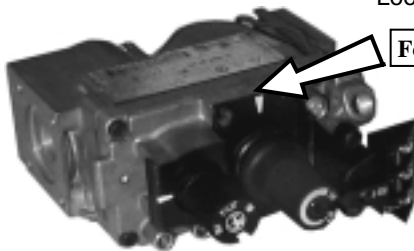

Look for this label:

**For LPG only | Pout 11" W.C.**

If the label is present, the heater is equipped for LP (propane). If the label is absent, the heater is equipped for NG (natural gas).

- This heater is either approved for natural gas (NG) or propane (LP). Burning the incorrect fuel will void the warranty and safety listing and may cause an extreme safety hazard. Check the label above the gas control valve to make sure it matches the fuel being used. Direct questions about the type of fuel used to your dealer.



- Contact your local building officials to obtain a permit and information on any installation restrictions or inspection requirements in your area. Notify your insurance company of this heater as well.



- If the flame becomes sooty, dark orange in color, or extremely tall, do not operate the heater. Call your dealer and arrange for proper servicing.

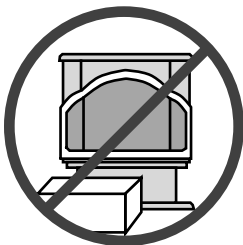

- It is imperative that control compartments, screens, or circulating air passageways of the heater be kept clean and free of obstructions. These areas provide the air necessary for safe operation.



- Do not operate the heater if it is not operating properly in any fashion or if you are uncertain. Call your dealer for a full explanation of your heater and what to expect.



- Do not store or use gasoline or other flammable liquids in the vicinity of this heater.

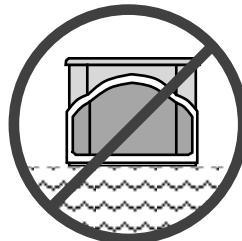

- Do not operate if any portion of the heater was submerged in water or if any corrosion occurs.



- Do not place clothing or other flammable items on or near the heater. Because this heater can be controlled by a thermostat there is a possibility of the heater turning on and igniting any items placed on or near it.

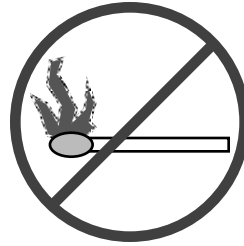

- Light the heater using the built-in piezo igniter. Do not use matches or any other external device to light your heater.
- Never remove, replace, modify or substitute any part of the heater unless



- The door (glass) should only be opened while lighting the pilot or conducting service. Damaged glass must be replaced.

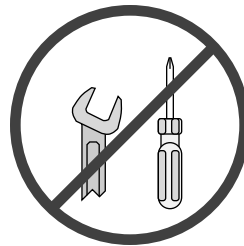

- instructions are given in this manual. All other work must be done by a trained technician. Don't modify or replace orifices.



- Any safety screen or guard removed for servicing must be replaced prior to operating the heater.
- Operate the heater according to the instructions included in this manual.
- If the main burners do not start correctly turn the gas off at the gas control valve and call your dealer for service.

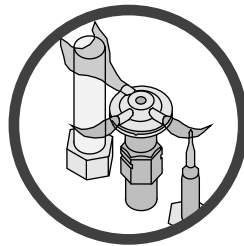

- Allow the heater to cool before carrying out any maintenance or cleaning.
- The pilot flame must contact the thermopile and thermocouple (see the illustration to the left). If it does not, turn the gas control valve to "OFF" and call your dealer.



- This unit is not for use with solid fuel
- Do not place anything inside the firebox (except the included fiber logs).
- If the fiber logs become damaged, replace with Travis Industries log set.



- Do not throw this manual away. This manual has important operating and maintenance instructions that you will need at a later time. Always follow the instructions in this manual.



- Do not touch the hot surfaces of the heater. Educate all children of the danger of a high-temperature heater. Young children should be supervised when they are in the same room as the heater.

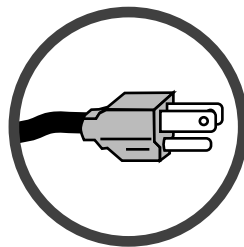

- Plug the heater into a 120V grounded electrical outlet. Do not remove the grounding plug.

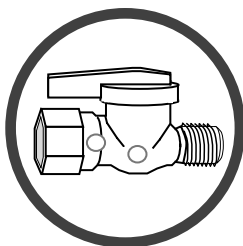

- Instruct everyone in the house how to shut gas off to the appliance and at the gas main shutoff valve. The gas main shutoff valve is usually next to the gas meter or propane tank and requires a wrench to shut off.



- Don't route the electrical cord in front of, over, or under the heater
- Travis Industries, Inc. grants no warranty, implied or stated, for the installation or maintenance of your heater, and assumes no responsibility of any consequential damage(s).**

## **Introduction**

|                            |   |
|----------------------------|---|
| Introduction.....          | 1 |
| Important Information..... | 1 |

## **Safety Precautions**

|                         |   |
|-------------------------|---|
| Safety Precautions..... | 2 |
|-------------------------|---|

## **Specifications**

|  |   |
|--|---|
| Installation Options.....                            | 5 |
| Features.....  | 5 |
| Heating Specifications.....                          | 5 |
| Dimensions.....                                      | 5 |
| Electrical Specifications (for optional blower)..... | 5 |
| Fuel.....  | 5 |

## **Installation**

|   |    |
|---|----|
| Installation Warnings.....                      | 6  |
| Packing List.....                               | 6  |
| Installation Preparation.....                   | 6  |
| Stove Clearances.....                           | 6  |
| Mobile Home Requirements.....                   | 6  |
| Heater Placement Requirements.....              | 7  |
| Floor Protection Requirements.....              | 7  |
| Gas Line Installation.....                      | 7  |
| Gas Inlet Pressure.....                         | 7  |
| Vent Requirements.....                          | 8  |
| Approved Vent Configurations.....               | 9  |
| Restrictor Position.....                        | 9  |
| Elbows.....                                     | 9  |
| Measuring Vent Lengths.....                     | 9  |
| Vertical Term's with 0, 2, or 4 45° Elbows..... | 10 |
| Horizontal Terminations with 1 90° Elbow.....   | 11 |
| Horizontal Term's with Two Elbows.....          | 12 |
| Horizontal Term's with Three 90° Elbows.....    | 13 |
| Vertical Term's with Two 90° Elbows.....        | 14 |
| Vertical Term's with Three 90° Elbows.....      | 15 |
| Horizontal Vent Termination Requirements.....   | 16 |
| Vertical Vent Termination Requirements.....     | 16 |
| Finalizing the Installation.....                | 17 |
| Opening the Door.....                           | 19 |
| Log Set and Coal Installation.....              | 20 |

## **Operation**

|   |    |
|---|----|
| Safety Notice.....                          | 21 |
| Location of Controls.....                   | 21 |
| Starting the Pilot Flame.....               | 22 |
| Starting the Heater for the First Time..... | 23 |
| Turning the Heater On and Off.....          | 23 |
| Adjusting the Flame Height.....             | 23 |
| Adjusting the Blower Speed.....             | 24 |
| Normal Operating Sounds.....                | 24 |
| Normal Operating Odors.....                 | 24 |

## **Maintenance**

|                               |    |
|-------------------------------|----|
| Cleaning Your Heater.....     | 25 |
| Yearly Service Procedure..... | 25 |
| Troubleshooting Steps.....    | 26 |
| How this Heater Works.....    | 27 |
| Wiring Diagram.....           | 28 |

## **Safety Label**

|                   |    |
|-------------------|----|
| Safety Label..... | 29 |
|-------------------|----|

## **Warranty**

|               |    |
|---------------|----|
| Warranty..... | 30 |
|---------------|----|

## **Optional Equipment**

|                                 |    |
|---------------------------------|----|
| LP Conversion Instructions..... | 31 |
| Blower.....                     | 34 |
| Gold Door.....                  | 36 |
| Gold Grill.....                 | 37 |
| Firebrick.....                  | 37 |

## **Installation Addenda**

|                               |    |
|-------------------------------|----|
| Interior Masonry Chimney..... | 38 |
| Class A Chimney Retrofit..... | 39 |

## **Index**

|            |    |
|------------|----|
| Index..... | 40 |
|------------|----|

## Features:

- Ember Fyre™ Burner for "Wood Fire" Look
- Works During Power Outages (millivolt system)
- High Efficiency
- Optional Thermostat or Remote Control
- Optional Blower for Quicker Heat Distribution
- Convenient Operating Controls
- Variable-Rate Heat Output
- Low Maintenance

## Installation Options:

- Freestanding Stove
- Horizontal or Vertical Vent
- Residential or Mobile Home
- Straight or Corner Placement
- Bedroom Approved

## Heating Specifications:

Approximate Heating Capacity (in square feet)\*.....500 - 1,500 with Blower, 500 to 1,200 Without  
 Maximum Input" (in BTU's per hour).....31,000  
 Input Rate on "LO" (in BTU's per hour) ..... 18,500 (LP) 23,000 (NG)  
 Steady State Efficiency.....up to 86.5%  
 AFUE (without blower) .....Up to 67.2%

- Heating capacity will vary depending on the home's floor plan, degree of insulation, and the outside temperature.

\*\* Efficiency rating is a product of thermal efficiency rating determined under continuous operation independent of installed system.

## Dimensions:

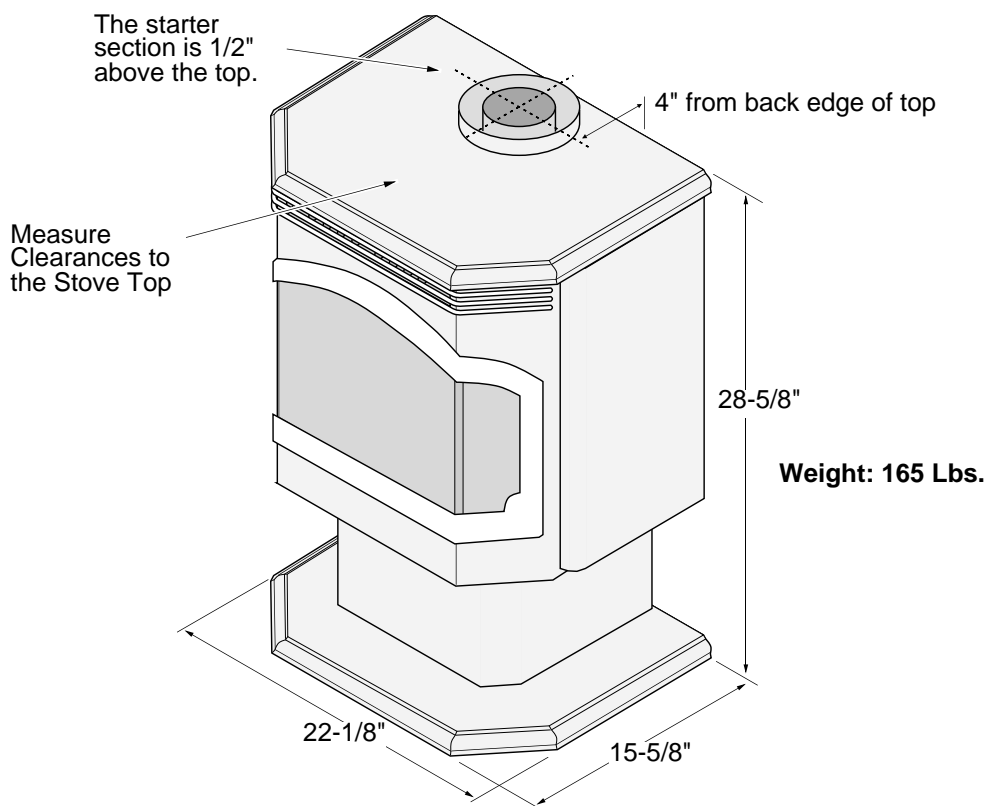

## Electrical Specifications (for optional blower)

Electrical Rating.....115 Volts, .8 Amps, 60 Hz (92 watts on high)

## Fuel:

This heater is shipped in natural gas (NG) configuration but may be converted to propane (LP) using the included LP conversion kit. The sticker on top of the gas control valve will verify the correct fuel.

## Installation Warnings

- ! Failure to follow all of the requirements may result in property damage, bodily injury, or even death.
- ! This heater must be installed by a qualified installer who has gone through a training program for the installation of direct vent gas appliances.
- ! This appliance must be installed in accordance with all local codes, if any; if not, follow current ANSI Z223.1 or NFPA 54 in the USA .
- ! In Manufactured or Mobile Homes this appliance must be installed to the applicable Mobile Home Standards: CAN/CSA Z240 MH, the Manufactured Home Construction and Safety Standard, Title 24 CFR, Criteria for Manufactured Home Installations, Sites and Communities, and/or ANSI/NFPA 501A. This appliance may be installed in Manufactured Housing only after the home is site located.
- ! This appliance is designed for natural gas or propane (LP). Check the sticker on top of the gas control valve.
- ! All exhaust gases must be vented outside the structure of the living-area. Combustion air is drawn from outside the living-area structure.
- ! Notify your insurance company before hooking up this appliance.
- ! The requirements below are divided into sections - all requirements must be met simultaneously.

## Packing List

- Allegiance
- Owner's Manual
- Log Set with Embers
- Propane Conversion Kit

## Installation Preparation

- HINT: If converting to LP, convert the appliance prior to installation.
- HINT: Install the logs last - they are fragile.
- HINT: When determining the location of the stove, locate the wall studs (for horizontal penetrations) and ceiling trusses (for vertical penetrations). You may wish to adjust the stove position slightly to ensure the vent does not intersect with a framing member.
- HINT: Fumes and smoke from the paint curing and oil burning off the steel may occur the first time you start this heater. This is normal. We recommend you open windows to vent the room.

## Stove Clearances

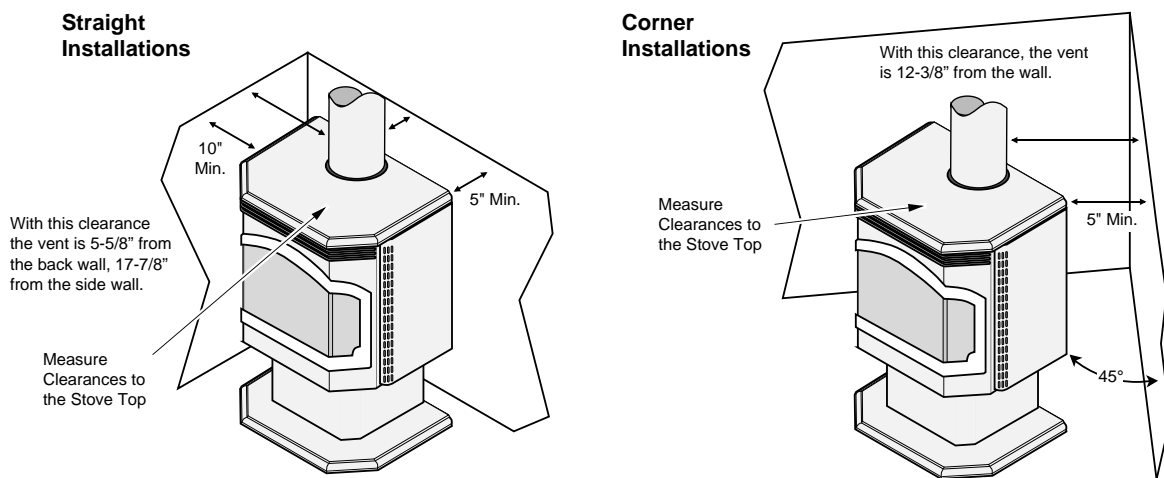

## Mobile Home Requirements

- When the stove is installed in a mobile home, it must be bolted to the floor and the appliance grounded (use the optional blower with a grounded circuit or other suitable grounding method - current ANSI/NFPA 70 or CSA C22.1).

## Heater Placement Requirements

- Heater must be installed on a level surface capable of supporting the heater and vent
- Due to the high temperature of the heater, it should be located out of traffic and away from furniture and draperies.
- ? When placed in a location where the floor to ceiling height is under 7 feet, the installation is considered an alcove and must meet the following requirements:
  - The alcove floor to ceiling height must be at least 58" tall
  - The alcove must not be more than 45" deep before the ceiling returns to 7'
  - The alcove must be at least 46-3/4" wide
- The heater must not be placed so the vents below or above the door, along the sides of heater, or along the back of the heater can become blocked.
- This heater may be placed in a bedroom. Please be aware of the large amount of heat this appliance produces when determining a location.

## Floor Protection Requirements

- When the stove is installed directly on carpeting, vinyl or other combustible material other than wood flooring or a high pressure laminate wood floor, the stove must be installed on a metal or wood protection panel extending the full width and depth of the heater (Minimum 22-1/8" wide by 15-5/8" deep).

## Gas Line Installation

- ! The gas line must be installed in accordance with all local codes, if any; if not, follow current ANSI Z223.1 or NFPA 54.
- ! The heater and gas control valve must be disconnected from the gas supply piping during any pressure testing of that system at test pressures in excess of 1/2 psig (3.45 kPa). For pressures under 1/2 psig (3.45 kPa), isolate the gas supply piping by closing the manual shutoff valve.
- This heater is designed for natural gas but can be converted to propane. Check sticker on top of gas control valve to verify correct fuel.
- Leak test all gas line joints and the gas control valve prior to and after starting the heater.
- The gas inlet accepts a 3/8" F.P.T. Fitting
- The location of the gas inlet is shown below
- A manual shutoff valve is required for installation (it must be located within 3' of the heater). T-Handle gas cocks are required in Massachusetts in compliance with code 248CMR.
- Installation must be performed by a qualified installer, service agency or the gas supplier (In Massachusetts a licensed plumber/gasfitter).

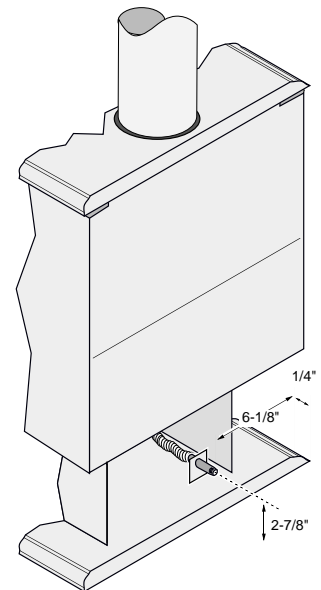

## Gas Inlet Pressure

- With the heater off, the inlet pressure must meet the requirements listed in the table below
- ? If the pressure is not sufficient, make sure the piping used is large enough and the total gas load for the residence does not exceed the amount supplied.
- ? The supply regulator (the regulator that attaches directly to the residence inlet or to the propane tank) should supply gas at the suggested input pressure listed below. Contact the local gas supplier if the regulator is at an improper pressure.

|             | Standard Input Pressure |
|-------------|-------------------------|
| Natural Gas | 7" W.C. (1.74 Kpa)      |
| Propane     | 13" W.C. (2.73 Kpa)     |



## Vent Requirements

- ! Always maintain the required 1" (25 mm) clearance (air space) to combustible materials to prevent a fire hazard. Do not fill air spaces with insulation.
- ! The gas appliance and vent system must be vented directly to the outside of the building, and never be attached to a chimney serving a separate solid fuel or gas-burning appliance. Each direct vent gas appliance must use it's own separate vent system.

## Altitude Considerations

This heater has been tested at altitudes ranging from sea level to 8,000 feet (2,400 M). In this testing we have found that the heater, with its standard orifice, burns correctly with just an air shutter adjustment.

- ! Failure to adjust the air shutter properly may lead to improper combustion which can create a safety hazard. Consult your dealer or installer if you suspect an improperly adjusted air shutter.
- When the vent passes through a wall, a wall thimble is required. When the vent passes through a ceiling, a support box or firestop is required. When the vent passes through the roof, a roof flashing and storm collar are required. Follow the instructions provided with the vent for installing these items.

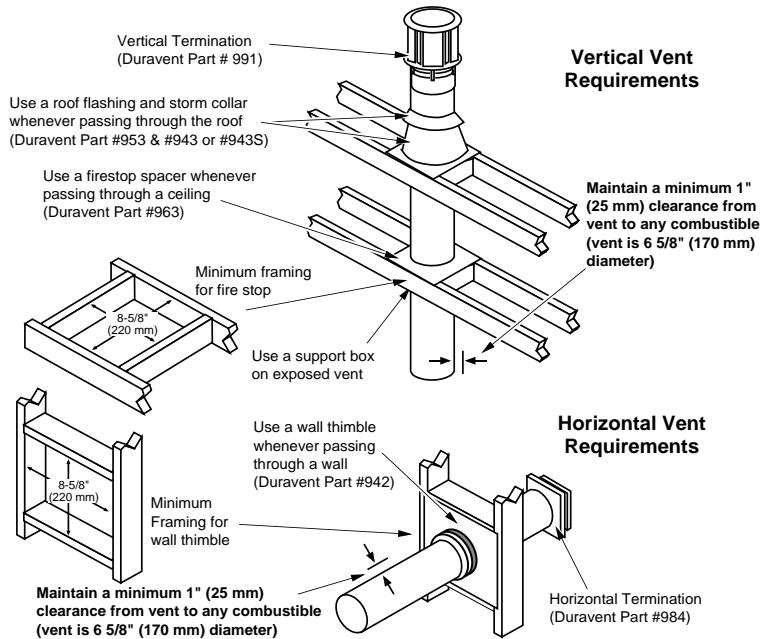

- Use of of the following 6-5/8" diameter co-axial gas direct vent systems:

| Manufacturer            | Series      |
|-------------------------|-------------|
| Simpson Dura-Vent       | Model GS    |
| Selkirk Hearth Products | Direct-Temp |
| American Metal Products | Ameri-Vent  |

**NOTE:** Always use the high-wind cap for the type of vent you are using (if applicable)

- Slide the vent sections together and turn 1/4 turn until the sections lock in place.
- Screws are not required to secure the vent. However, three screws may be used to secure vent sections together if desired.
- High temperature sealant is recommended at the appliance starter section connection (use high-temperature silicone or Mill-Pac®).
- If disassembly is required, at time of re-assembly check to see if the vent creates a tight fit. If it does not, apply high temperature sealant to the joints of the affected sections.
- Horizontal sections require a 1/4" rise every 12" of travel
- Horizontal sections require non-combustible support every three feet (e.g.: plumbing tape)

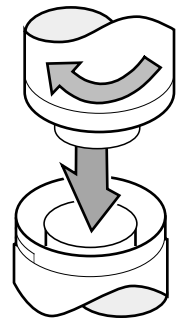

## Approved Vent Configurations

### Restrictor Position

- A vent restrictor is built into the appliance to control the flow rate of exhaust gases. This ensures proper flames for the wide variety of vent configurations. The restrictor consists of a butterfly valve in the air inlet and an adjustment plate with index holes used to hold the valve in a fixed position. Depending upon the vent configuration, you may be required to adjust the restrictor position. The charts for approved vent configurations describe which position the vent restrictor must be in.

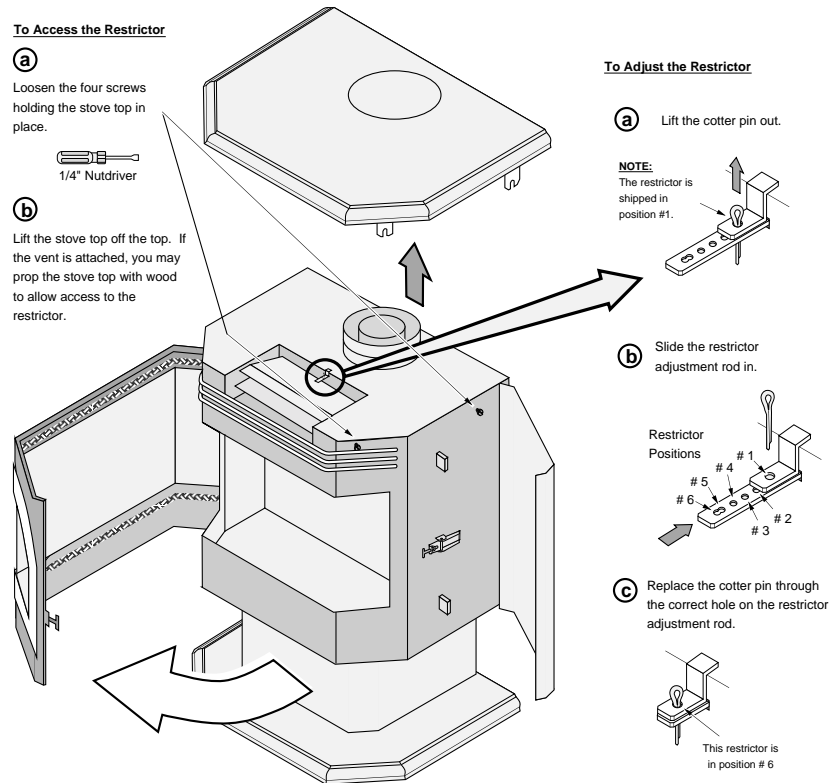

### Elbows

- 3 Elbow maximum (or four 45° elbows)

Vent Horizontal Run  
(measure from the closest edge of the starter section to the end of the termination)

### Measuring Vent Lengths

Vent Height is calculated to the top of the vent on horizontal terminations and to the top of the termination on vertical terminations.

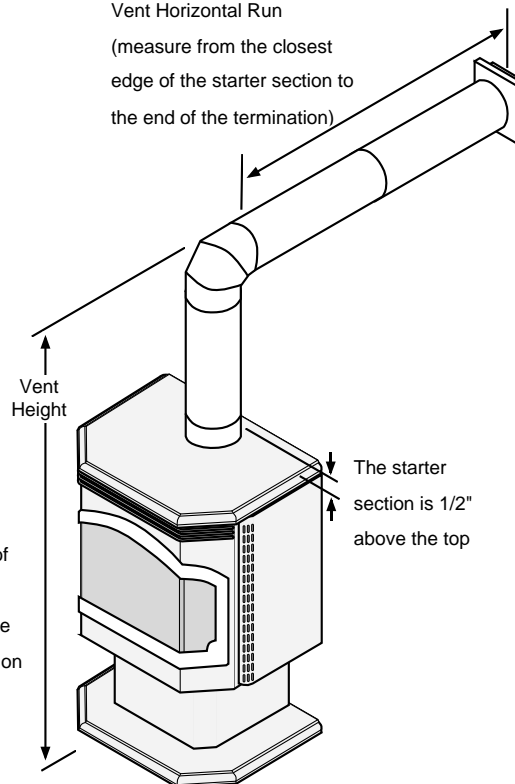

## Approved Venting Configurations for Vertical Terminations with Zero, Two, or Four 45° Elbows

- 10' Minimum System Height (with or without offsets)
- 40' Maximum System Height
- 24' Maximum Offset
- The termination must fall within the shaded area shown in the chart. Use the indicated restrictor position.
- If using offsets, use the table below to calculate the vertical rise and horizontal offset

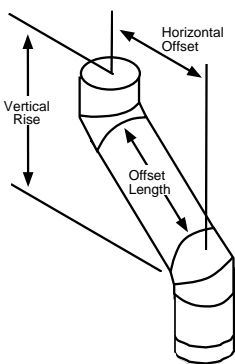

| Offset Length   | Hor. Offset | Vert. Rise |
|-----------------|-------------|------------|
| None            | 5"          | 1'         |
| 1' Section      | 1'          | 1' 7"      |
| 2' Section      | 1' 9"       | 2' 4"      |
| 3' Section      | 2' 5"       | 3'         |
| 4' Section      | 3' 2"       | 3' 8"      |
| 4' + 1' Section | 3' 9"       | 4' 4"      |
| 4' + 2' Section | 4' 6"       | 5'         |
| 4' + 3' Section | 5' 2"       | 5' 9"      |
| 4' + 4' Section | 6'          | 6' 9"      |

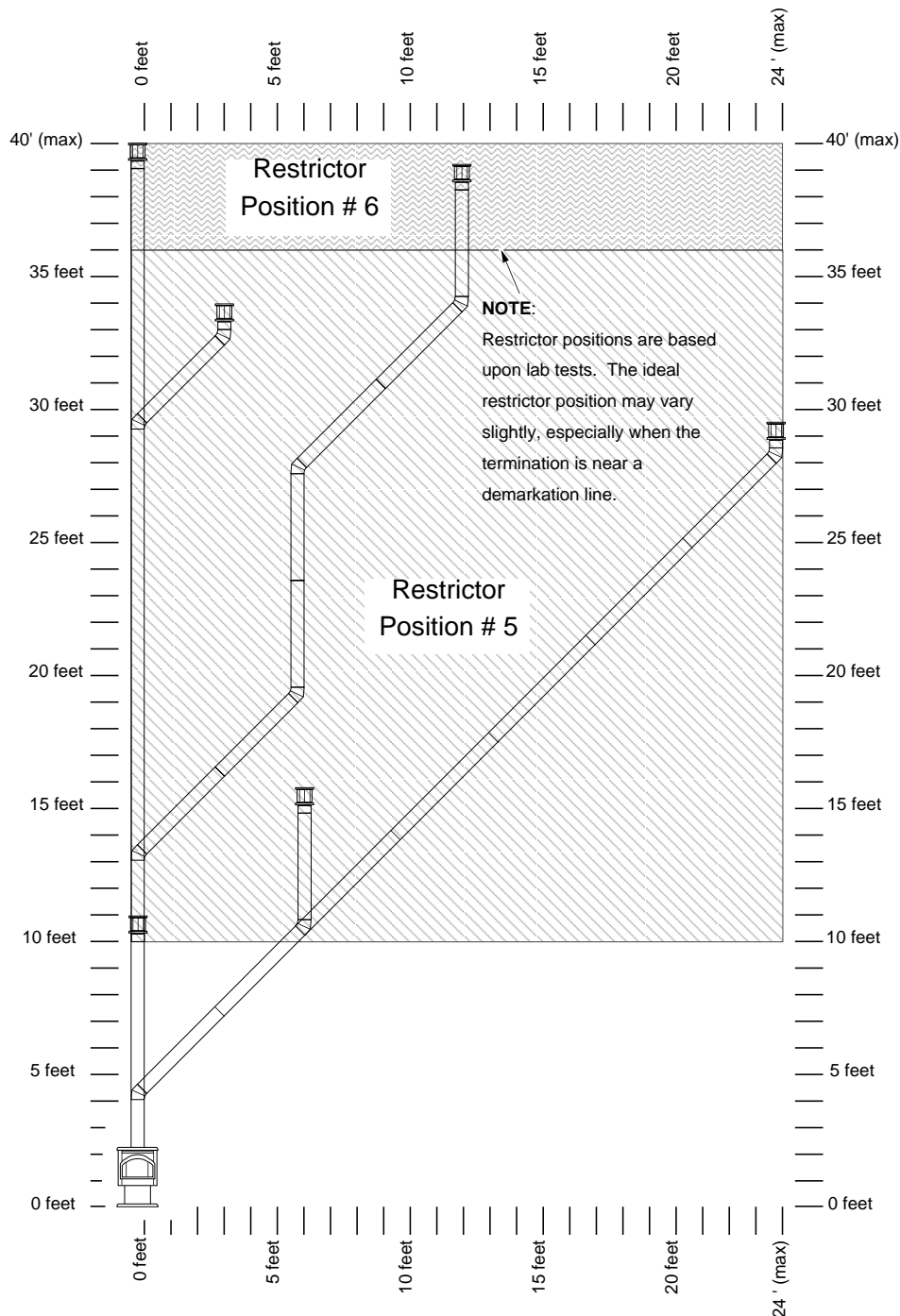

## Approved Venting Configurations with a Horizontal Termination and One 90° Elbow

- If using a Snorkel Termination (14" or 36") add the snorkel height to the vertical height (snorkel terminations are used primarily for basement installations).
- The termination must fall within the shaded area shown in the chart. Use the indicated restrictor position.

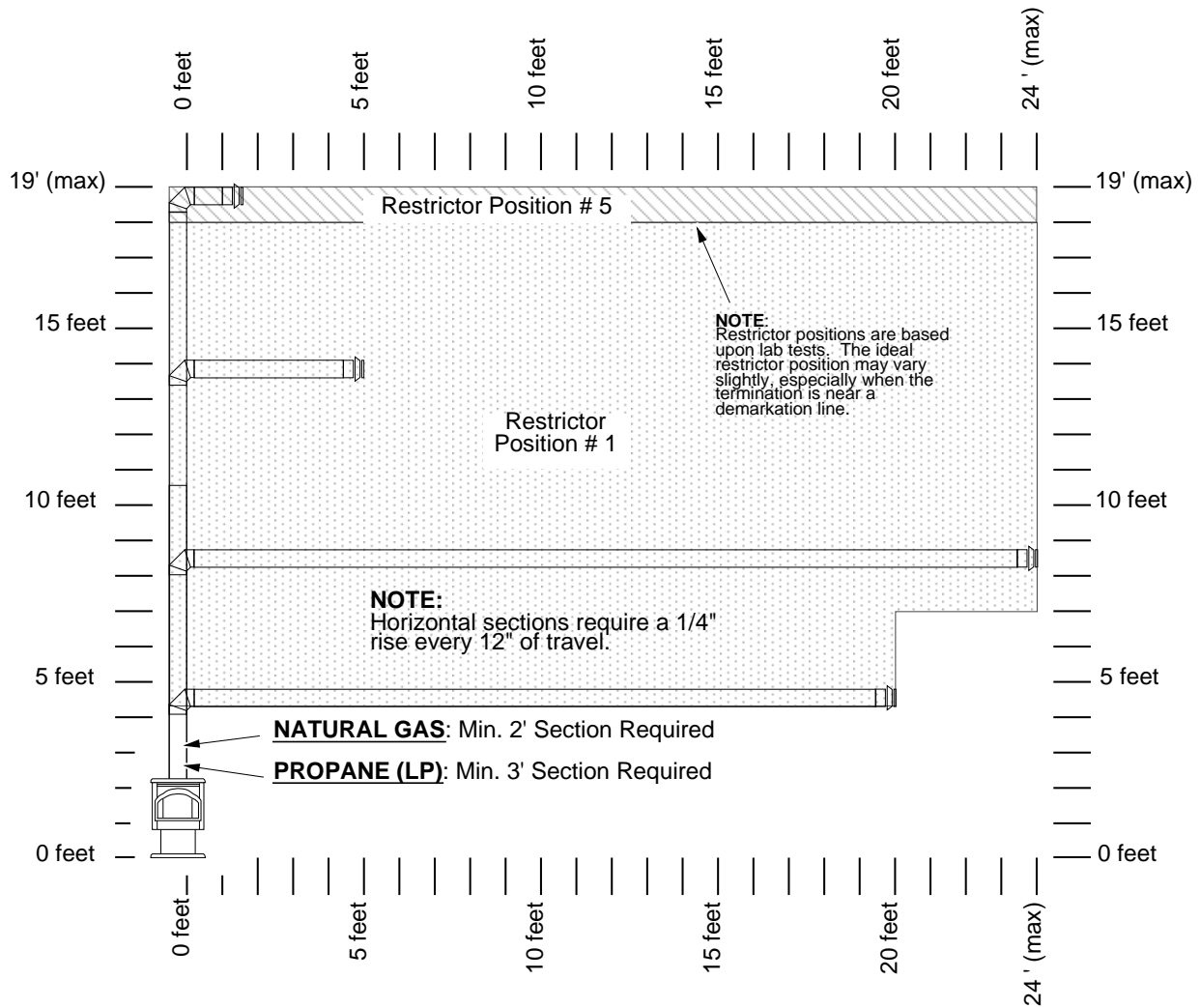

## Approved Venting Configurations with a Horizontal Termination and Two Elbows (one 90° vertical and one 90° or 45° horizontal elbow)

- If using a Snorkel Termination (14" or 36") add the snorkel height to the vertical height (snorkel terminations are used primarily for basement installations).
- The termination must fall within the shaded area shown in the chart. Use the indicated restrictor position.

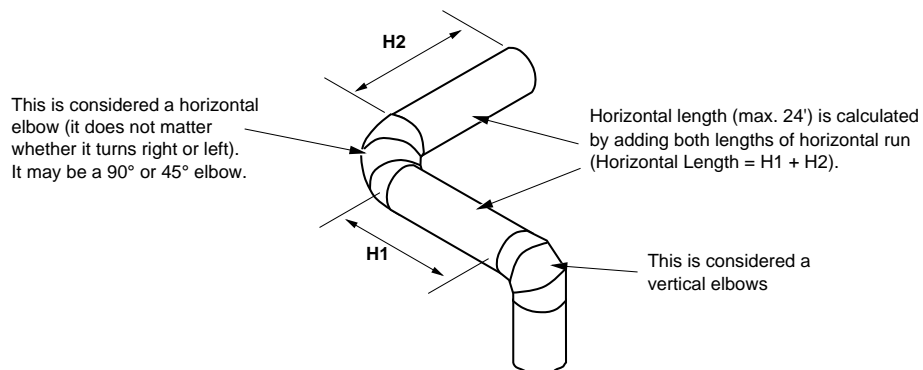
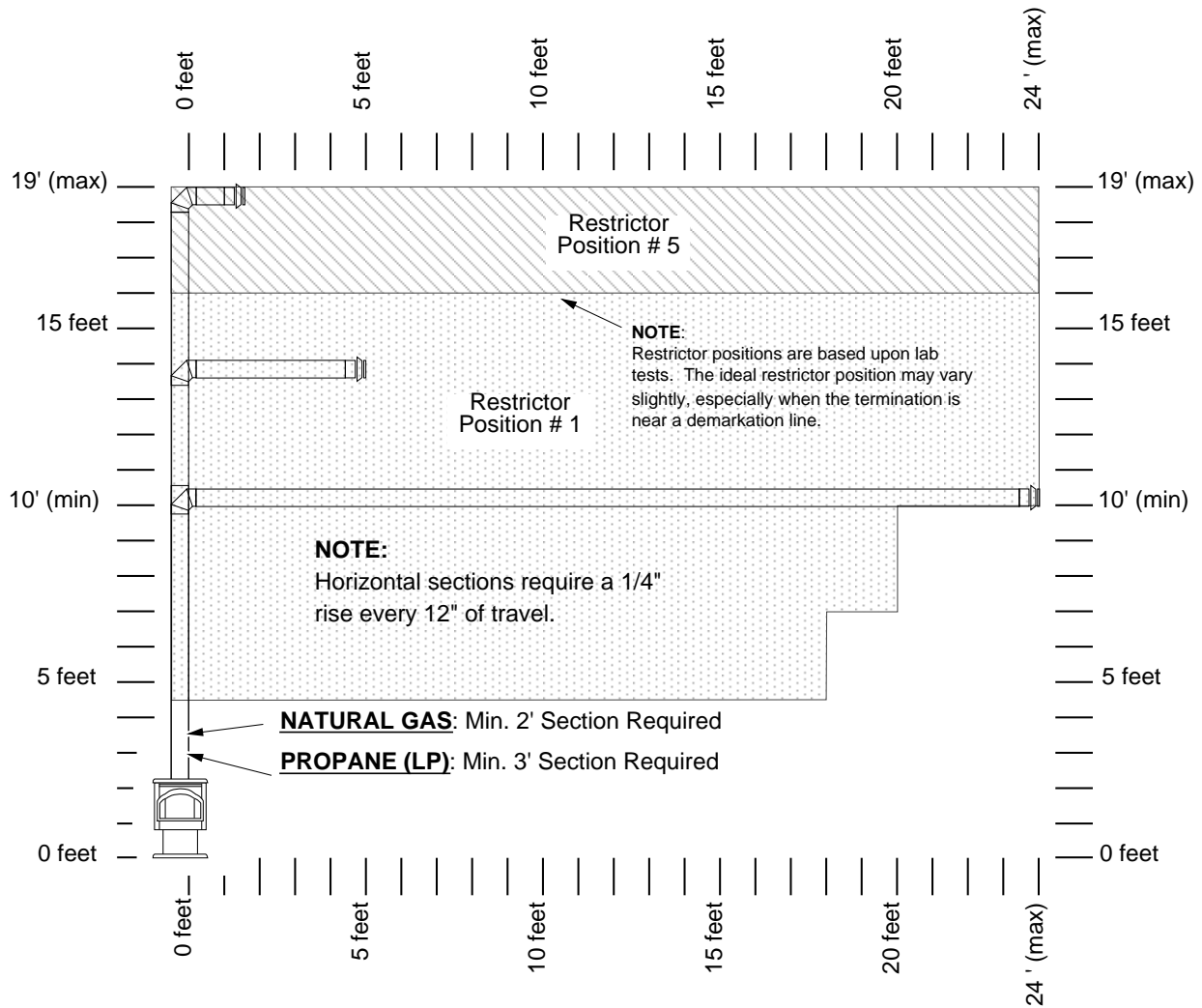

## Approved Venting Configurations with a Horizontal Termination and Three 90° Elbows (all vertical)

- If using a Snorkel Termination (14" or 36") add the snorkel height to the vertical height (snorkel terminations are used primarily for basement installations).
- The termination must fall within the shaded area shown in the chart. Use the indicated restrictor position.

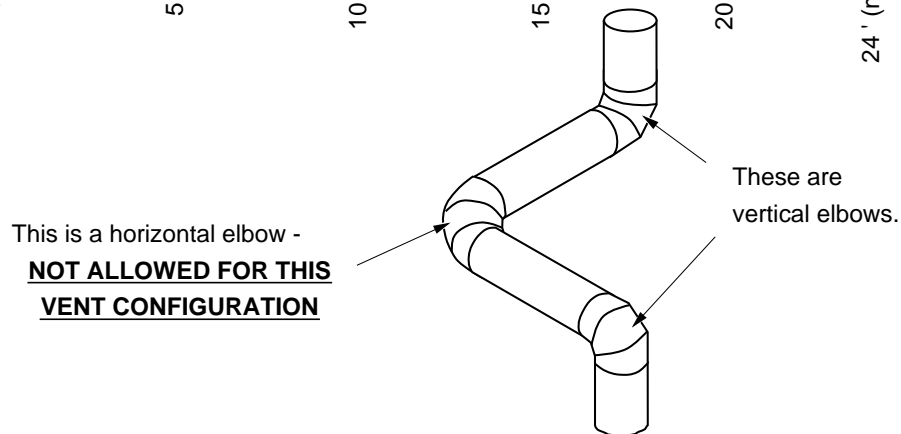
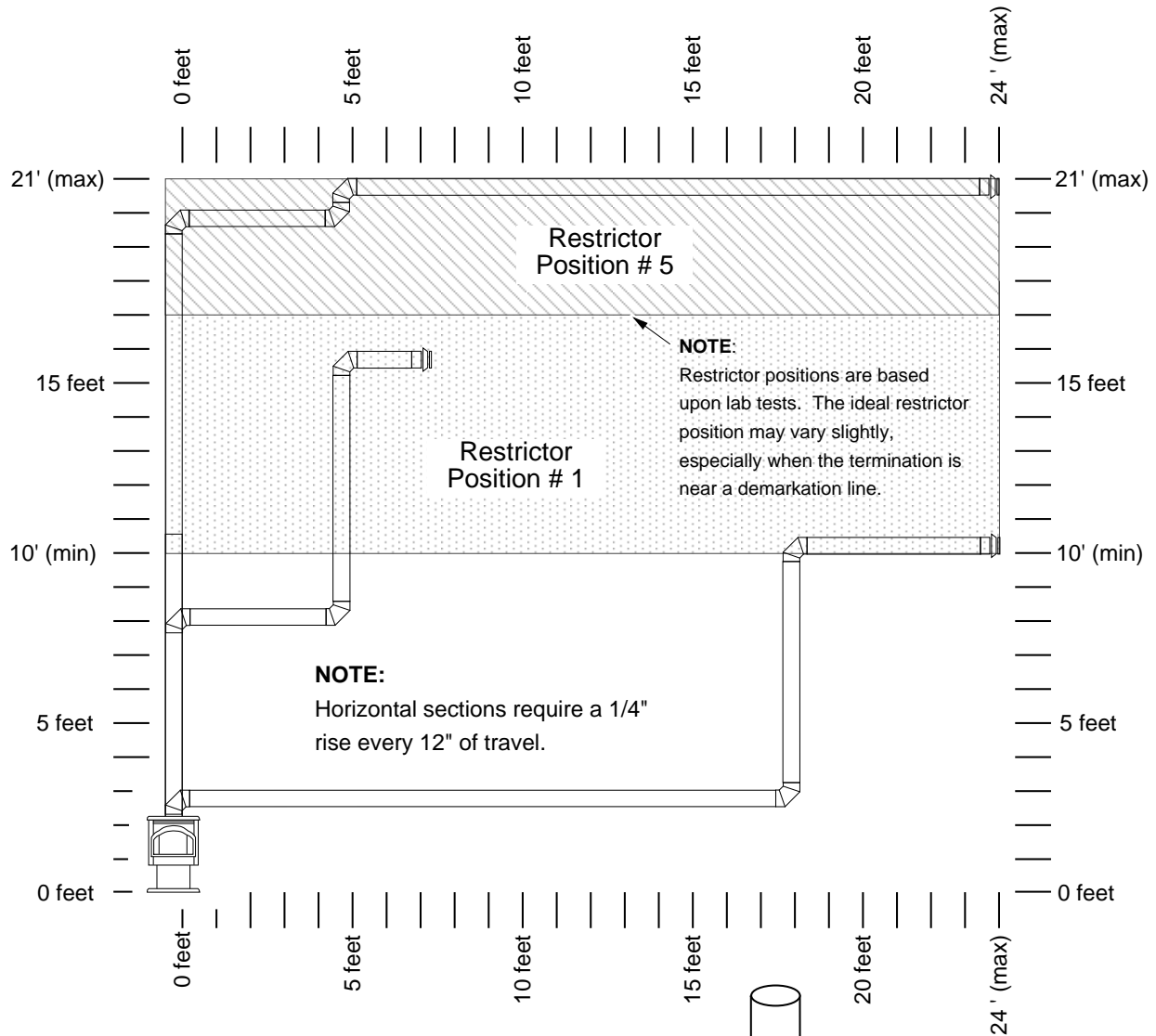

## Approved Venting Configurations for Vertical Terminations with Two 90° Elbows

- The termination must fall within the shaded area shown in the chart. Use the indicated restrictor position.

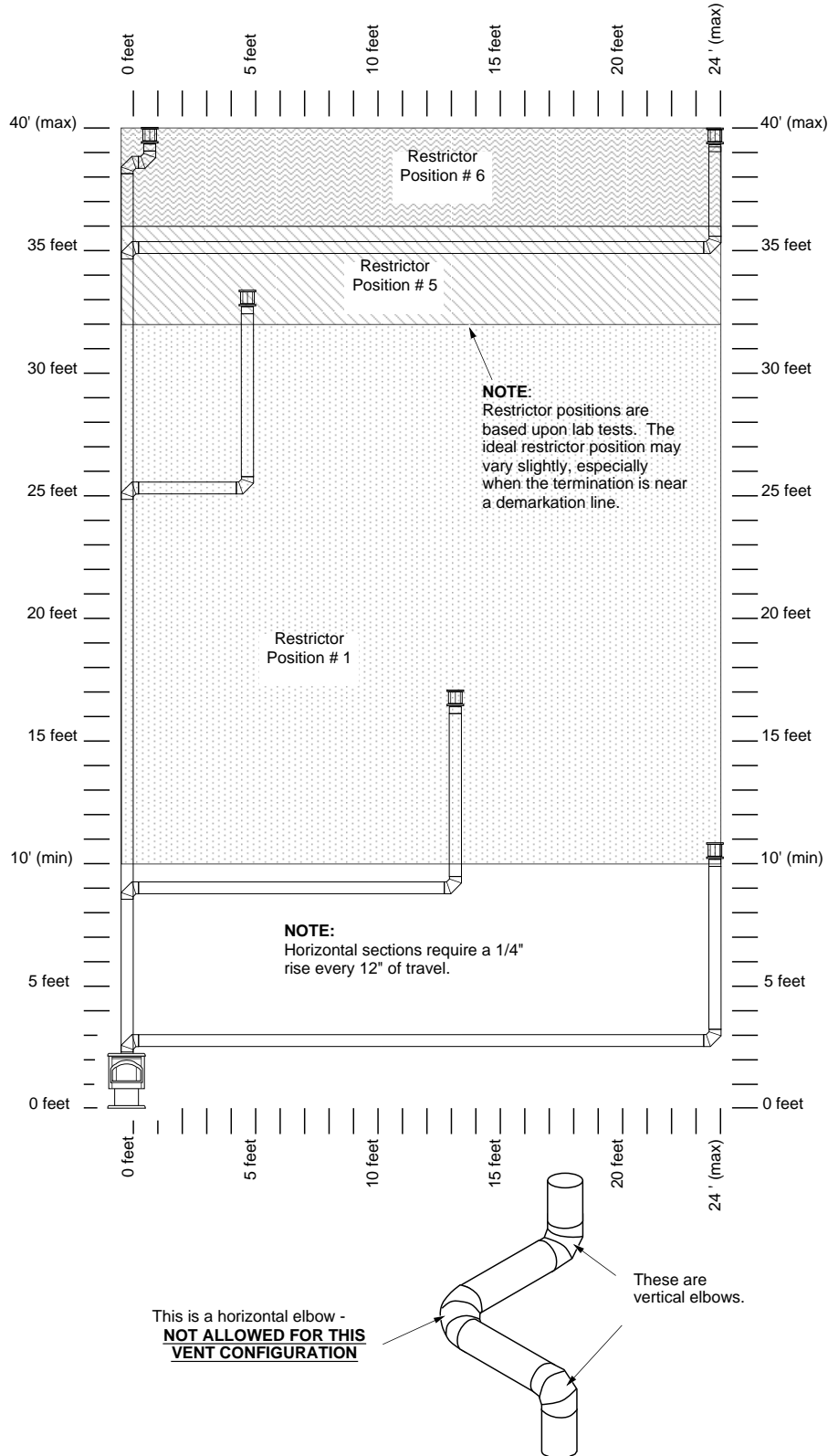

## Approved Venting Configurations for Vertical Terminations with Three 90° Elbows (Two 90° Vertical and One 45° or 90° Horizontal Elbow)

- The termination must fall within the shaded area shown in the chart. Use the indicated restrictor position.

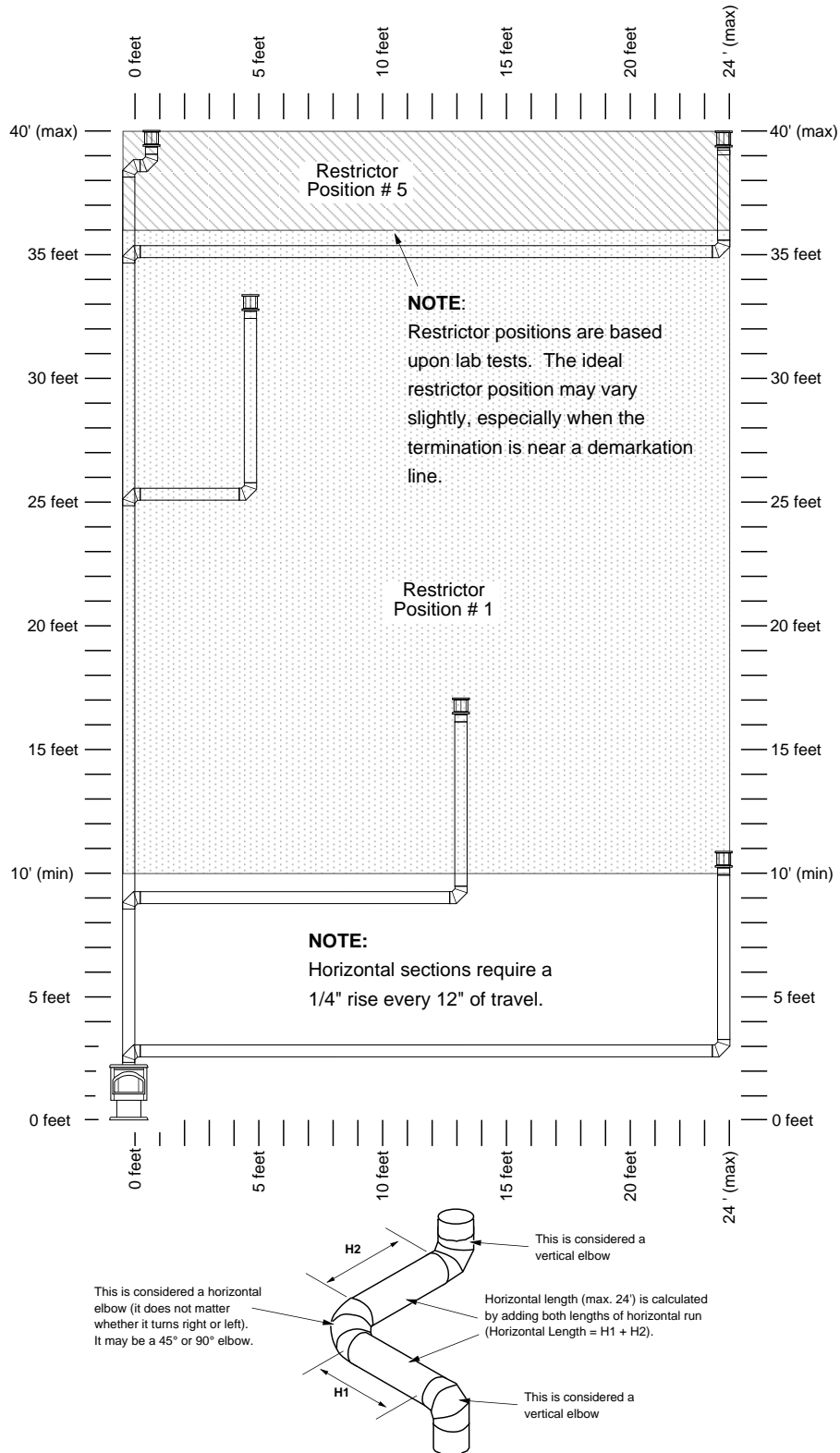



## ***Vent Termination Requirements (see illustration below)***

**!** Venting terminals shall not be recessed into a wall or siding.

- A Minimum 9" clearance from any door or window
- B Minimum 12" above any grade, veranda, porch, deck or balcony
- C Minimum 12" from outside corner walls
- D Minimum 12" from inside corner walls
- E Minimum 11" clearance below unventilated soffits or roof surfaces  
Minimum 18" clearance below ventilated soffits  
Minimum 6" clearance from roof eaves
- NOTE:** Vinyl surfaces require 24"
- F Minimum 18" clearance below a veranda, porch, deck or balcony (must have two open sides)
- G Minimum 48" clearance from any adjacent building
- H Minimum 84" clearance above any grade when adjacent to public walkways or driveways  
**NOTE:** may not be used over a walkway or driveway shared by an adjacent building
- I Minimum 48" clearance from any mechanical air supply inlet.
- J Minimum 36" clearance above and 48" below and to the sides of non-mechanical air supply inlet
- K Minimum 36" from the area above the meter/regulator (vent outlet)
- L Minimum 36" from the meter/regulator (vent outlet)
- M Minimum 12" above the roof line (for vertical terminations)
- N Minimum 24" horizontal clearance to any surface (such as an exterior wall) – for vertical terminations

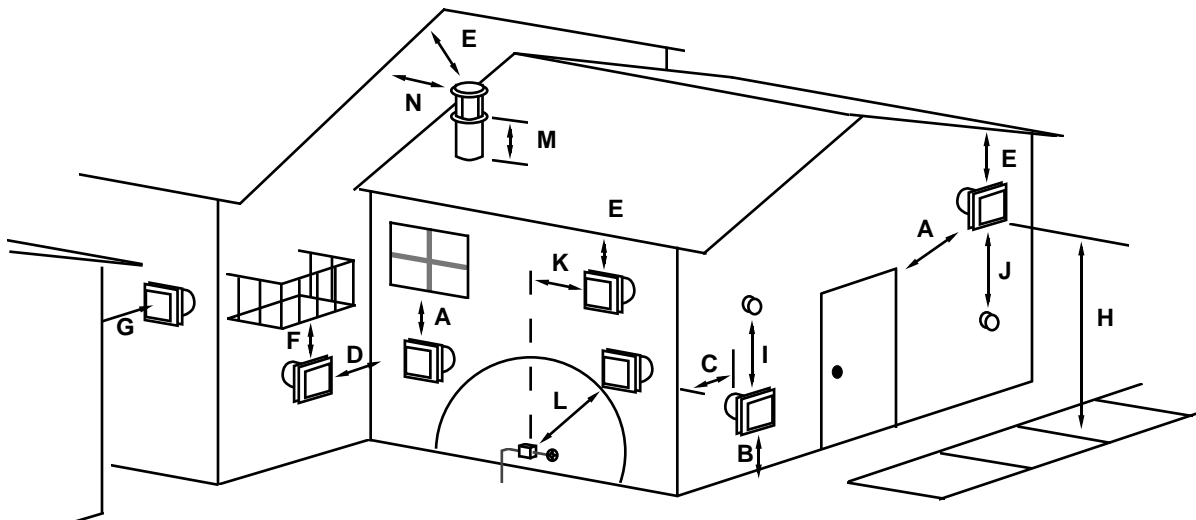
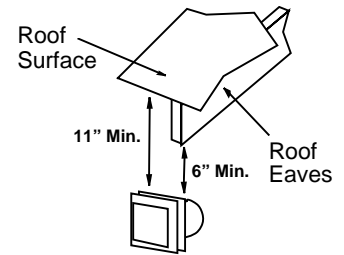

**NOTE: Measure clearances to the nearest edge of the exhaust hood.**

- Use the vinyl siding standoff (#1250) when installing on an exterior with vinyl siding.
- Vent termination must not be located where it will become plugged by snow or other material
- These clearances meet UMC-1994 and the CNA/CGA-B149 code standards.

## Finalizing the Installation

- ! Turn the gas control valve to "OFF" prior to conducting any service.
- 1 Open the door (see page 16)
- 2 Install the log set and coals (see page 17).
- ! We recommend you purge the gas line at this time (with the door open). This allows gas to be detected once it enters the firebox, ensuring gas does not build up.
- 3 Close and secure the door (see page 16)
- 4 Turn on gas to the heater. Leak test all gas joints prior to starting the appliance. Start the pilot. Start the main burner. Leak test all gas joints again.
- 5 Check the pilot flame to make sure it looks like the illustration to the below. Adjust the pilot flame if necessary.

To adjust the pilot flame, turn this screw (NOTE: if totally unscrewed gas will come out of this port). Clockwise lowers the flame while counter-clockwise raises it.

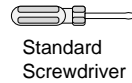

The pilot flame must contact the thermocouple and thermopile (see the illustration below). Adjust the pilot up or down as necessary.

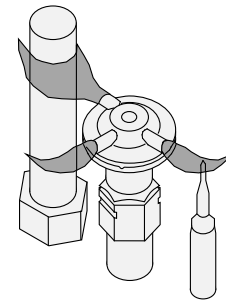
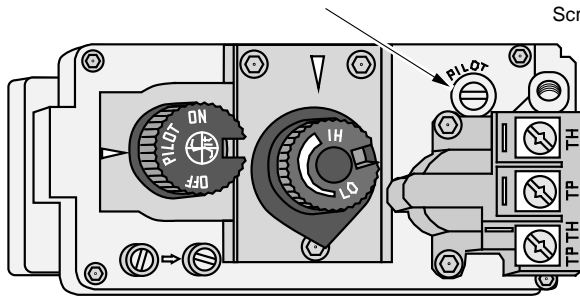

- 6 Let the heater burn for thirty minutes. Adjust the air shutter, if necessary, to achieve the correct looking flame (see the illustration to on the following page).
- The air shutter adjusts the amount of air that mixes with the gas before it exits the burner holes. It is used to fine-tune the flame for differences in altitude and vent configuration.
- ! If the air shutter is in its fully open position, yet the flames remain sooty, shut off gas to the heater and contact your dealer for a remedy.

### ADJUSTING THE AIR SHUTTER

Pushing to the right gives the flame less air (making it more orange). Pushing to the left gives the flame more air, making it more blue. For fine adjustments use a screwdriver to tap the air shutter.

**NOTE:** If the air shutter is all the way open, yet the flames remain sooty, shut off gas to the fireplace and contact a qualified gas service technician.

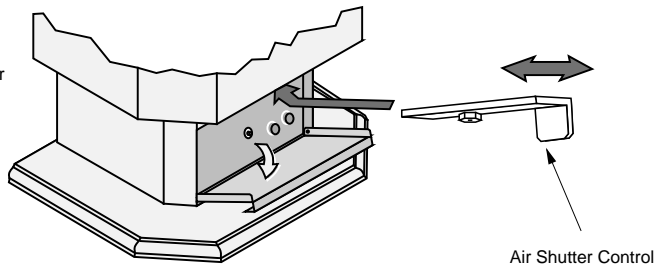

**NOTE:** The logs must be installed correctly to monitor the flame while adjusting the air shutter.

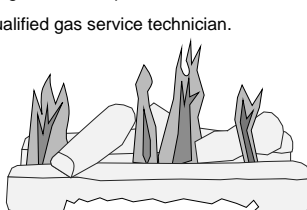

**Correct**

Flames should be blue at the base, yellow-orange on the top.

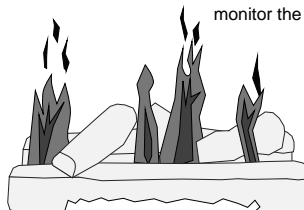

**Not Enough Air**

If the flames are over 14" tall or sooty on the ends, open the air shutter.

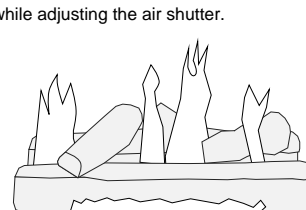

**Too Much Air**

If the flames are all blue and short, close the air shutter.

- ! If the vent configuration is installed incorrectly the vent may cause the flames inside the heater to lift or “ghost” – a dangerous situation. Inspect the flames after installation to insure proper performance. If the vent configuration is correct, yet the flames are lifting or ghosting, shut off gas to the heater and contact the dealer for information on remedying the problem.

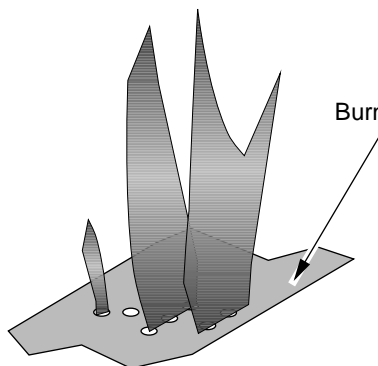

The flames should burn right off the top of the burner ports (if they are too blue, adjust the air control).

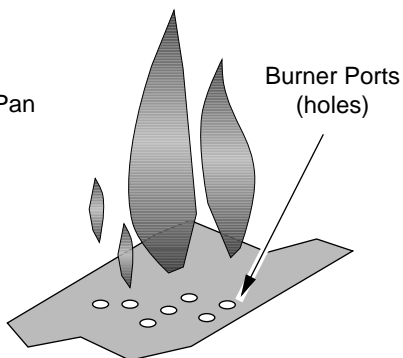

If the flames are lifting, yet the vent configuration is correct, contact your dealer.

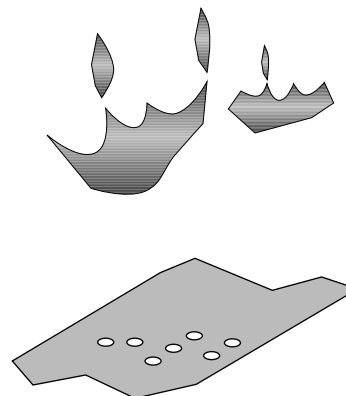

If the flames are ghosting, yet the vent configuration is correct, contact your dealer.

- 7 Turn the flame adjust knob to its highest position - the flames should be a maximum 9" to 10" tall. Check the flame on low position. The flames should burn off of each burner hole. If the heater does not work correctly, contact your dealer for a remedy.
- 8 **Give this manual to the home owner and fully explain the operation of this heater.**

## Opening the Door

**WARNING:** The front of the stove becomes very hot during operation. Let the stove cool completely before conducting service.

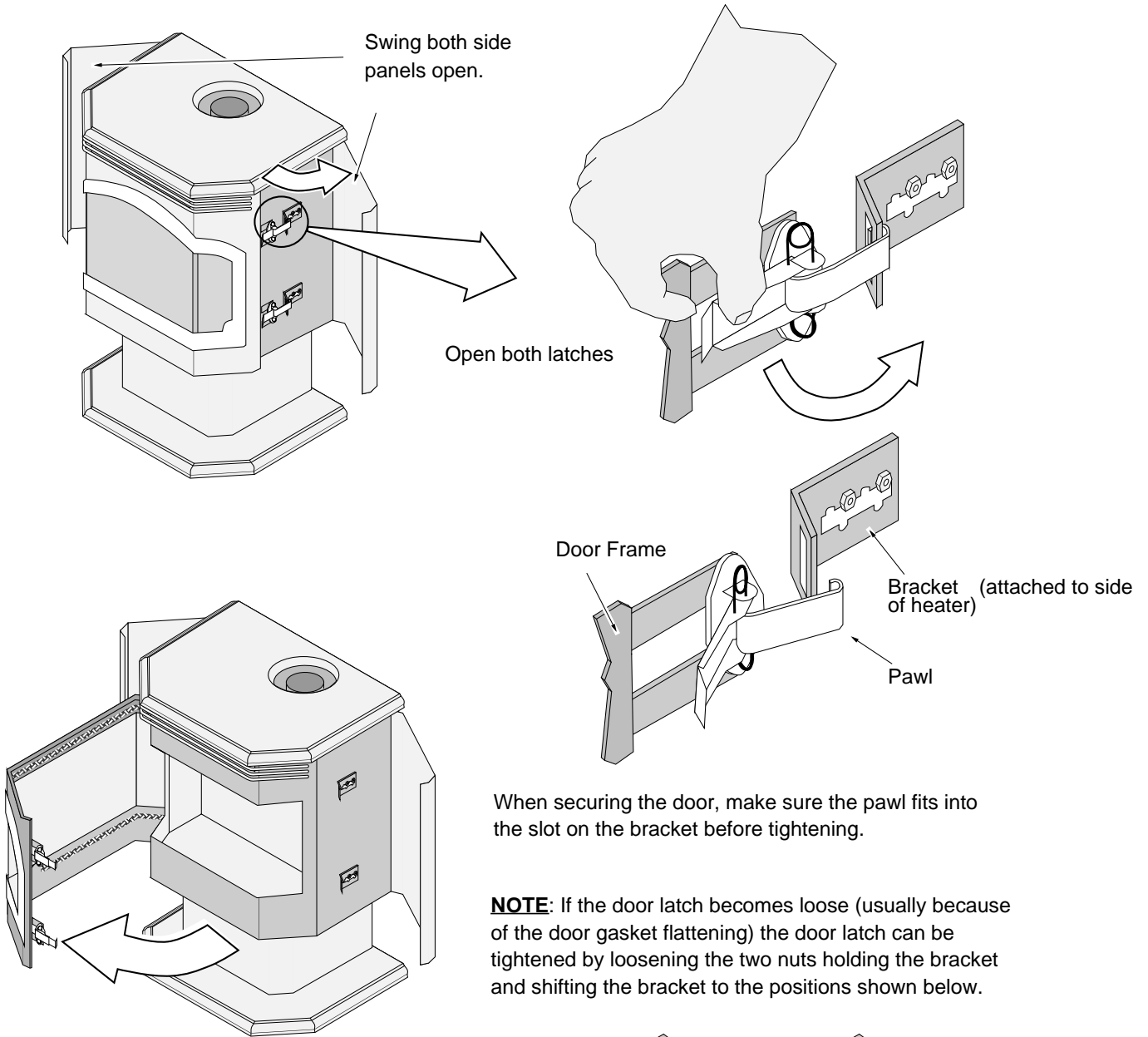

With both pawls free of the brackets, the door may be swung open.

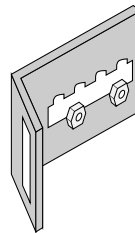

Tighter

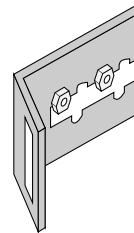

Tightest

***Log Set and Coal Installation***

Place the rear log so the pins on the burner insert into the holes on the bottom of the log.

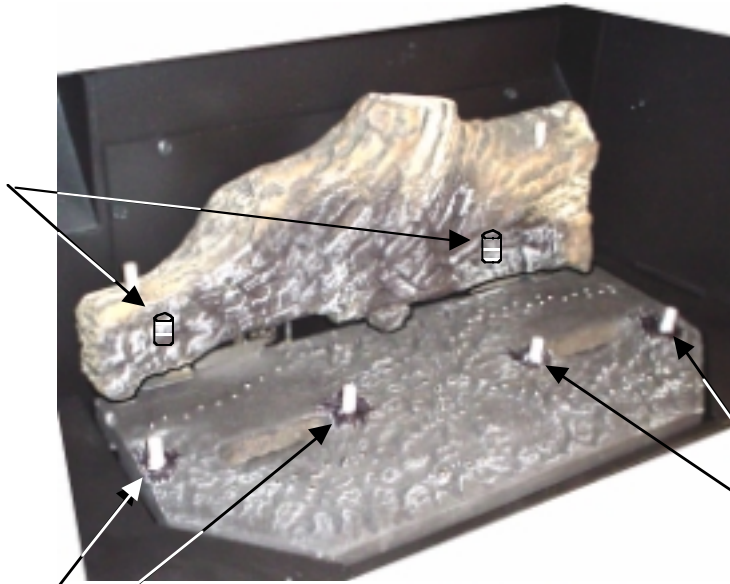

Place the right log so the pins (or bolts) on the burner insert into the holes on the bottom of the log.

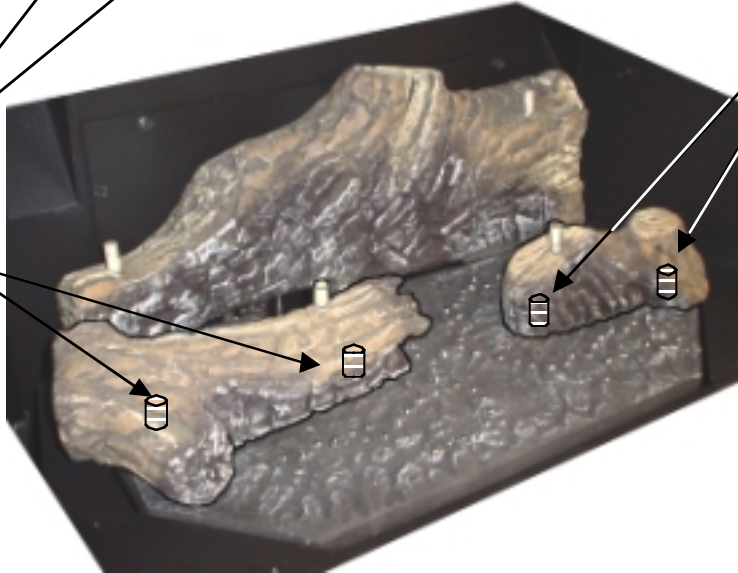

Place the left log so the pins (or bolts) on the burner insert into the holes on the bottom of the log.

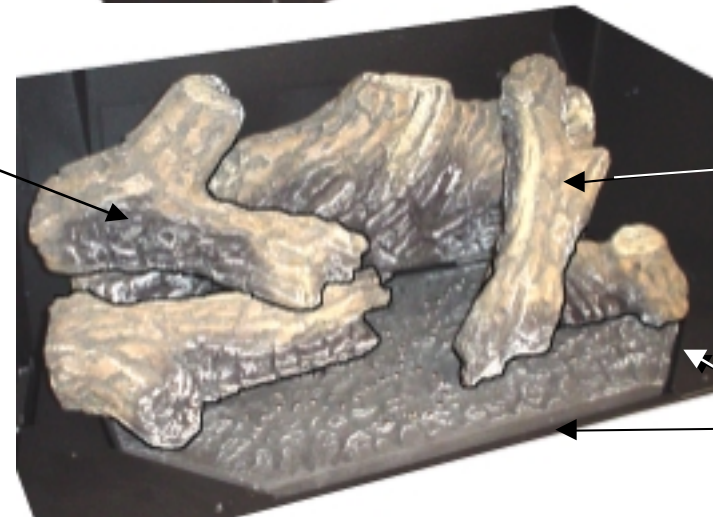

Place the left twig so the pins on the logs insert into the holes on the bottom of the twig.

Place the right twig so the pins on the logs insert into the holes on the bottom of the twig.

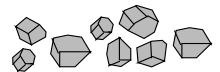

Place the ember chunks around the perimeter of the burner to conceal the gap.

## Safety Notice

Read this entire manual (especially the “Safety Precautions” on pages 2 and 3) before using this stove. Failure to follow the instructions may result in property damage, bodily injury, or even death.

## Location of Controls

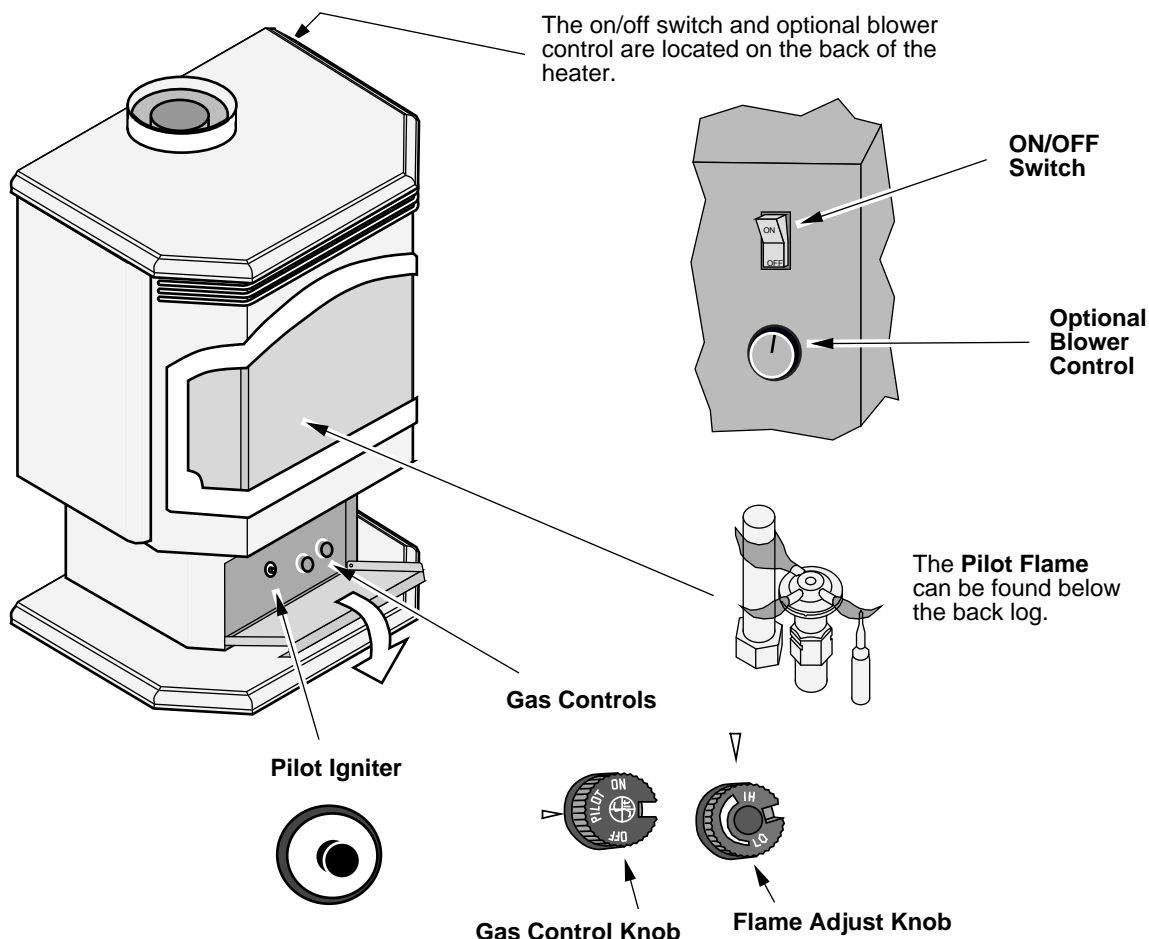

**On/Off Switch**

This control is used to turn the main burner on and off.

**Gas Control Knob**

This knob is used to control gas to the heater and for starting the pilot. There are three positions, ON, OFF, & PILOT. The pointer directly below the knob indicates the position this knob is in.

**Flame Adjust Knob**

This knob controls the flame height from low (“LO”) to high (“HI”). The pointer to the upper left of the knob points to the position this knob is in.

**Pilot Igniter**

The pilot igniter is used only to start the pilot. When pressed, it sends an electrical charge to the pilot assembly. This creates a blue spark directly next to the pilot, igniting the pilot flame.

**Blower Knob**

This knob controls the speed of the internal convection blower that pushes the heated air into the room.

? If using a remote control or thermostat, the On/Off Switch must be left “ON”. Turning the On/Off Switch “OFF” will keep the heater off always.

## Starting The Pilot Flame

The pilot flame is required to ignite the main burners (it also plays a safety role). It should be left on once lit. It will stay lit unless the gas control valve is turned to "OFF". However, the pilot will go out if the gas is shut off, the propane tank runs out (or low) or if the stove malfunctions. If the pilot turns off frequently, call your dealer for information. To start the pilot follow the directions below:

### **WARNING:**

**When lighting or re-lighting the pilot, the door must be opened (see page 16).**

- a Open the door (see page 16 for details).
- b Push the gas control knob in slightly and turn it to the "OFF" position. The knob will not turn from "ON" to "OFF" unless the knob is depressed slightly. Wait five minutes to let any gas that may have accumulated inside the firebox escape. If you smell leaking gas, follow the directions on the cover "IF YOU SMELL GAS".
- c Turn the gas control knob to the "PILOT" position and press the knob in, this will allow gas to flow to the pilot light. Press the button on the pilot igniter repeatedly until you see the pilot light.

### **WARNING:**

**If the pilot does not light after 15 seconds, release the knob and call your dealer for service. Do not attempt to light pilot until service has been performed.**

### **NOTE:**

**You may wish to remove the log set to gain a better view of the pilot (see page 17).**

- d Keep the gas control knob depressed for 30 seconds once it is lit.
- e Release the gas control knob. If the pilot goes out, repeat step C. If the pilot refuses to stay lit, call your dealer for service. With the pilot lit, proceed to step "f".
- f Close the door.
- g Turn the gas control knob counter-clockwise to "ON". The pilot is now lit and the heater can be turned on and off.

a

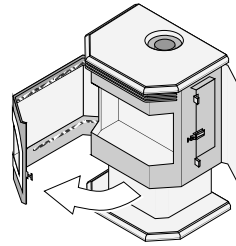

b

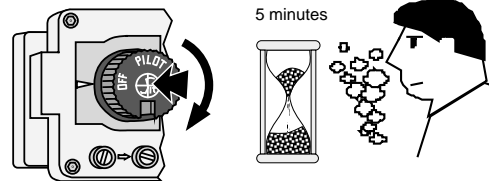

c

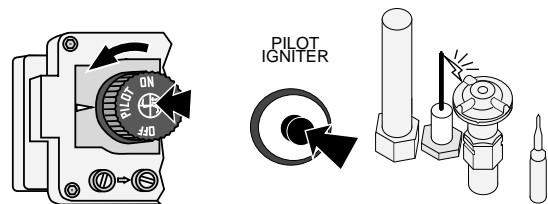

d

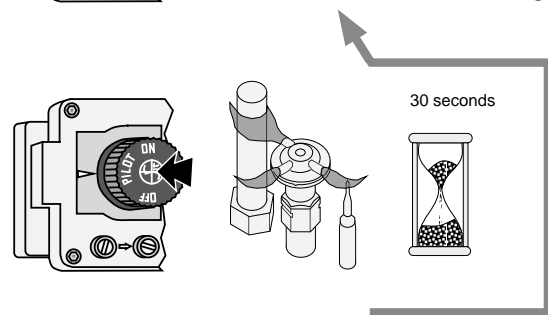

e

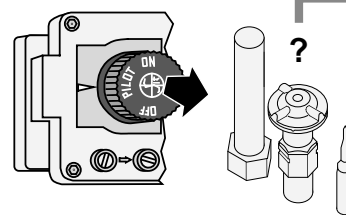

f

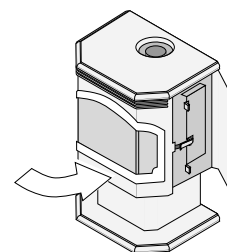

g

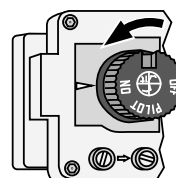

## Starting the Heater for the First Time

### Cleaning Gold Surfaces

Fingerprints or other marks left on gold surfaces may become etched in place if they are not wiped clean prior to turning the stove on. Clean gold surfaces with denatured alcohol and a soft cloth when the heater is cold.

### Fumes from the Painted Surfaces Curing

Burn the heater at a medium setting for approximately one hour the first time. This will cure the painted surfaces. **Fumes** from the paint curing and oil burning off the steel may occur. This is normal. We recommend you open the window to vent the room.

### Condensation

Water may appear on the glass each time you start the heater - this is normal.

### Blue Flames

The flames will be blue when first started. After fifteen minutes the flames will turn a more realistic yellow and orange color.

## Turning the Heater On and Off

After the pilot has been started...

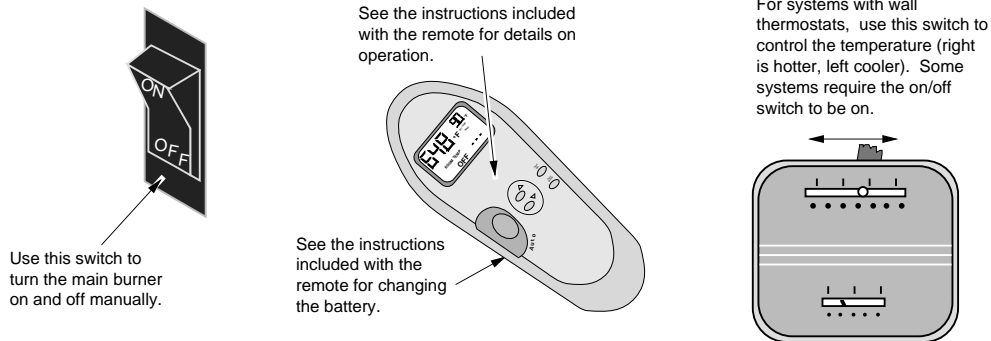

**Warning:** Do not place combustible items on top or directly in front of the heater, even temporarily. The optional thermostat may start the heater causing a combustible item to ignite.

**Note:** If the heater turns on and off frequently while using the thermostat, you may want to adjust the flame height down until it produces just enough heat needed.

## Adjusting the Flame Height

Your heater has an adjustable flame to tailor the look and heat output to your specific needs. It is adjusted by turning the middle dial on the gas control valve.

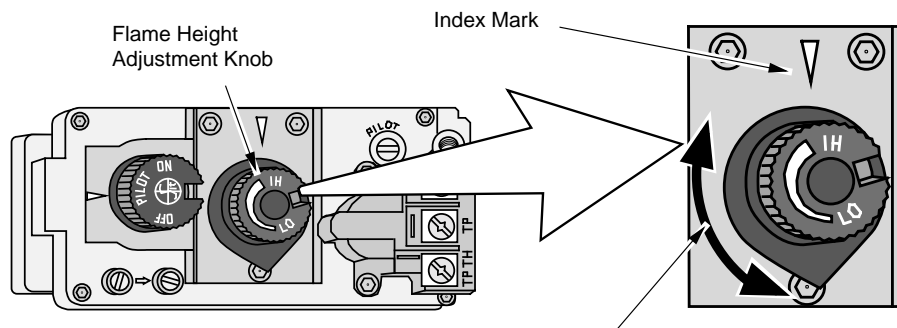

Turn counter-clockwise to adjust the flame higher, clockwise to lower.



## Adjusting the Blower Speed (optional)

The blower helps transfer the heat from the heater into the room. It will not turn on until the heater is up to temperature (approximately 10 minutes after starting). See the illustration below for instructions on adjusting the blower speed.

### OFF

Turn the dial all the way counter-clockwise until it clicks off.



### HIGH

The high position is all the way counter-clockwise, **without** clicking off.

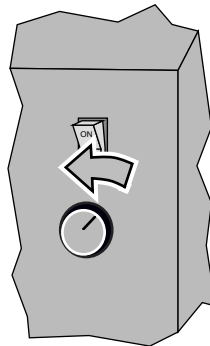

### LOW

Turn the dial all the way clockwise.

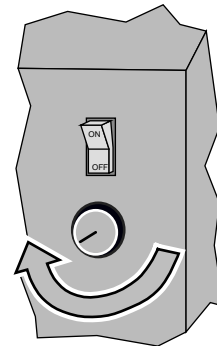

## Normal Operating Sounds

### **Pilot Flame**

The pilot flame, which remains on, makes a very slight "whisper" sound.

### **Gas Control Valve**

As the gas control valve is turned on and off you will hear a dull clicking sound. This is the valve opening up and shutting down.

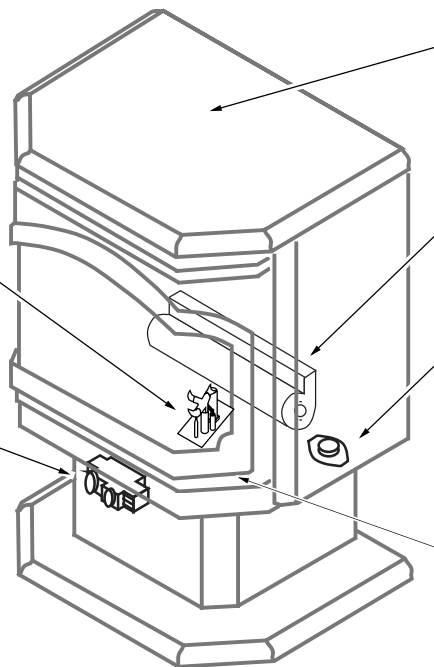

The appliance may creak with change of temperature -- THIS IS NORMAL.

### **Optional Blower**

This heater uses a blower to push heated air into the room. You will hear the sound of air movement that increases as the speed is increased.

### **Blower Snap Disk**

This part can produce a clicking sound as it turns the blower on and off.

### **Extinction Pops**

It is not unusual, especially on Propane (LP) appliances, to experience a "pop"

## Normal Operating Odors

This appliance has several areas that reach high temperatures. Dust or other particles on these areas may burn and create a burnt-paper smell. This is normal during startup. You may notice the smell is more acute if the appliance was left idle for a long period.

## Cleaning Your Heater

**Warning** Fingerprints or other marks left on the optional gold surface may become etched in place if they are not wiped clean prior to turning the stove on.

With the heater cool, use denatured alcohol and a soft cloth to clean gold surfaces. Other cleaners may leave a film that may become etched into the gold.

## Yearly Service Procedure

**Warning:** Failure to inspect and maintain the heater may lead to improper combustion and a potentially dangerous situation. We recommend the following procedures be done by a qualified technician.

- 1 Check the pilot flame. It should engulf approximately 3/8" of the top of the thermocouple (see illustration below). If it does not, contact your dealer for service.
- 2 Shut off gas to the heater by turning the gas control knob to "OFF" (see step A under "Starting the Pilot" on page 19). Let the heater cool for 15 minutes. Open the door (page 16) and remove the glass (page 14).
- 3 Remove the log set and embers (see page 15 - **NOTE: the log set is fragile**). If any log is cracked or deteriorated, replace it when re-installing. Check the logs for sooting. If excessive sooting is found, the heater will require adjustment. Contact your dealer.
- 4 Clean the burner pan (especially the burner holes) and inspect the following:
  - Check for burner for cracks, warps, or other damage.
  - Check the firebox and area around the pilot to make sure there is no warping or damage.

If any problem is found, discontinue use and contact your dealer for service.

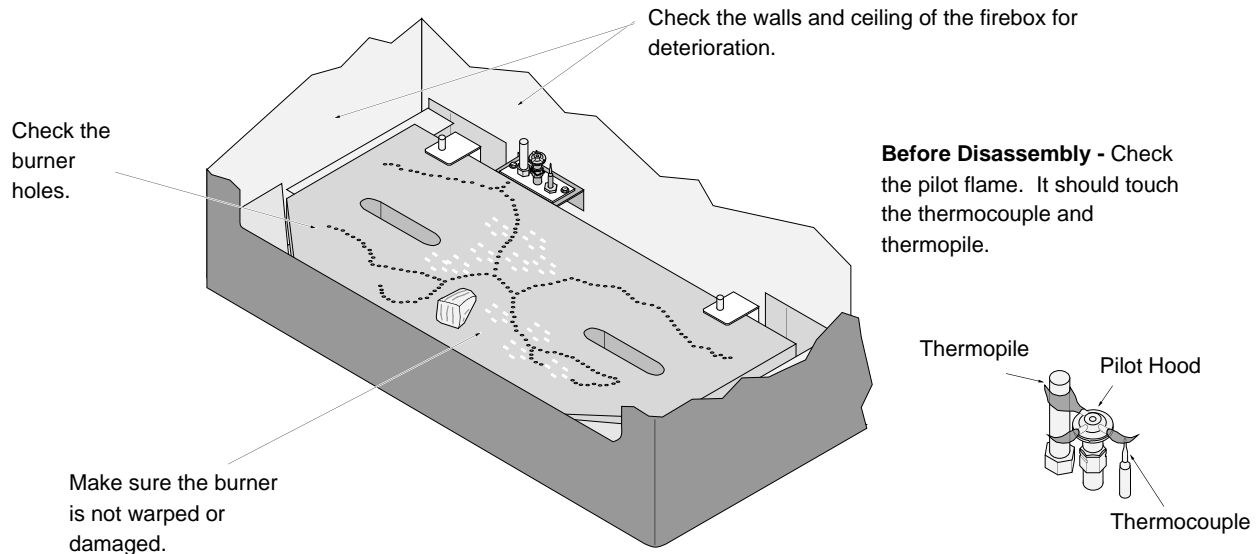

- 5 Replace the log set. Inspect the glass gasket. If it is deteriorated, replace. If the glass is damaged, replace it.
- 6 Check the gas control valve and all of the gas lines. If any damage is found, discontinue use and contact your dealer for service. Clean the air channels and ducts.
- 7 To check the door seal, place a dollar bill along the door perimeter then close and latch the door. If the dollar bill is held in place securely, the door seal is adequate. However, if the dollar bill slides out easily, you should adjust the door. Contact your dealer to obtain directions on tightening the door seal.
- 8 Start the pilot and turn on the main burner. The flames should be orange/yellow and not touch the top of the firebox. If the pilot or main burners do not burn correctly, contact your dealer for service. Monitor the blower operation.
- 9 Remove any debris or vegetation near the vent termination. Contact your dealer if any sooting or deterioration is found near the vent termination.

**Troubleshooting Steps**

| <b><u>Problem:</u></b>                 | <b><u>Possible Cause:</u></b>  | <b><u>Remedy:</u></b>   |
|--|--|---|
| <b>Pilot Will Not Flame</b>            | A gas shut off valve is turned off.....<br>The gas control knob isn't turned to "PILOT".....<br>The valve control knob isn't pushed in.....<br>The igniter wasn't pressed repeatedly.....<br>No spark from igniter.....  | Check all gas shut off valves<br>See "Starting the Pilot Flame" Pg 19<br>See "Starting the Pilot Flame" Pg 19<br>See "Starting the Pilot Flame" Pg 19<br>Igniter Faulty - Contact your Dealer                                       |
| <b>Main Burners Will Not Start</b>     | The pilot flame has gone out.....<br>The gas control valve is turned to "PILOT" or "OFF"<br>The ON/OFF switch is turned to "OFF".....<br>The remote control is not working correctly.....<br>The thermostat is disconnected or set too high ...  | See "Starting the Pilot Flame" Pg 19<br>See "Starting the Pilot Flame" Pg 19<br>Turn the ON/OFF switch to "ON"<br>Replace the batteries<br>Set the thermostat to a lower temperature  |
| <b>Remote Control Does Not Work</b>    | The pilot light has gone out.....<br>The gas control valve is turned to "PILOT" or "OFF"<br>The ON/OFF switch is turned to "OFF".....<br>The remote is too far away from the heater.....<br>The remote control receiver is turned "OFF".....<br>One of the two remote control batteries is dead... | See "Starting the Pilot Flame" Pg 19<br>See "Starting the Pilot Flame" Pg 19<br>Turn the ON/OFF switch to "ON"<br>Use the remote closer to the heater<br>See the remote control instructions<br>See the remote control instructions |
| <b>Thermostat Does Not Work</b>        | The pilot flame has gone out.....<br>The gas control valve is turned to "PILOT" or "OFF"<br>The ON/OFF switch is turned to "OFF".....<br>The thermostat is set too high.....   | See "Starting the Pilot Flame" Pg 19<br>See "Starting the Pilot Flame" Pg 19<br>Turn the ON/OFF switch to "ON"<br>Set the thermostat to a lower temperature   |
| <b>Blower Does Not Operate</b>         | Make sure blower control is turned "ON"<br>The heater is not getting electricity.....<br>The heater is not up to temperature.....  | See "Adjusting Blower Speed" Pg. 21<br>Make sure it is plugged in and the outlet is providing electricity<br>See "Operating Your Heater"  |
| <b>Flames Are Too Blue</b>             | The heater has just been started.....  | This is normal - see "Starting the Heater for the First Time"   |
| <b>Flames Are Too Short (Under 6")</b> | The flame height may be turned too low.....  | Turn the flame height to "HI" -<br>See "Adjusting the Flame Height"   |

## How this Heater Works

**Warning** This heater was designed with safety as the primary concern. Many of the components inside this heater are for safety purposes. Therefore, only certified gas service technicians should service this heater.

### What Turns the Main Burners On and Off

This heater uses a millivolt system to control its operation (a millivolt is a very small amount of electricity). The thermopile and thermocouple generate electricity when heated by the pilot flame. This electricity is used to operate the gas valve. Without enough electricity, the gas valve will not turn on. That is why when starting the pilot the gas control knob has to be pressed in long enough for the thermocouple to heat up and generate enough electricity. The thermopile provides power for the ON/OFF switch, remote control, or thermostat (see the illustration below). Because the thermopile generates the electricity needed to turn the heater on and off, this heater can be operated when the power is out (although the blower will not run).

When heated, the thermopile generates electricity (a very small amount measured in "Millivolts").

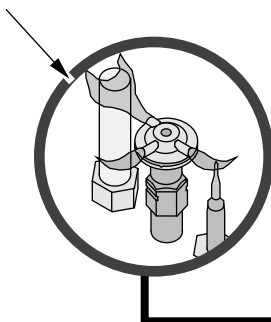

This electricity is used to operate the main burners.

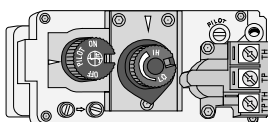

The main burners are switched on and off using the electricity generated by the thermopile. The ON/OFF switch, remote control, or thermostat control the circuit to the main burner.

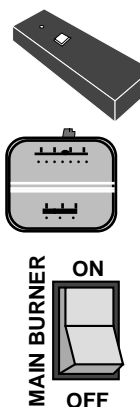

### What Prevents Gas Buildup

- This appliance utilizes a high-technology gas valve in conjunction with a pilot flame to ensure no gas builds up inside the firebox.
- The thermocouple (next to the pilot) senses when the pilot flame is lit. If the pilot flame goes out, this thermocouple no longer generates electricity, causing the gas valve to automatically shut off all gas to the heater, preventing the pilot or burner from spilling gas into the firebox.

#### Pilot Flame

The pilot flame is a time-proven component that eliminates the possibility of gas buildup inside the firebox.

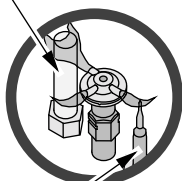

#### Thermocouple

The thermocouple generates a small amount of electricity. If the pilot flame goes out, the gas valve automatically shuts off all gas.

#### Gas Valve

This high-technology valve automatically shuts off all gas if it does not receive a signal from the thermocouple. If any component is damaged or sensing a malfunction, or if the wiring is damaged, it will shut off all gas.

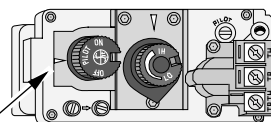

#### External Shut Off Valve

This valve is placed on the gas line to shut off gas to the appliance during maintenance procedures.

#### Ceramic Glass

The glass in your heater is the most durable glass available. It has been tested to be extremely resistant to breakage from temperature changes.

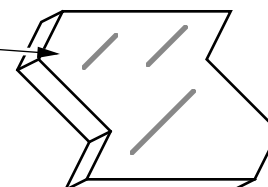

## Wiring Diagram

### Millivolt Wiring (for gas control valve)

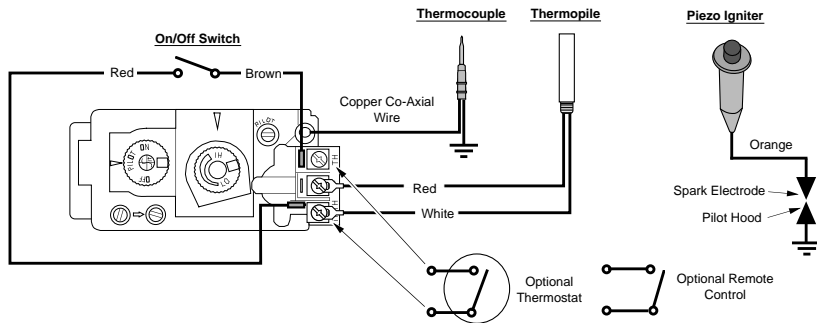

### 120 Volt Wiring

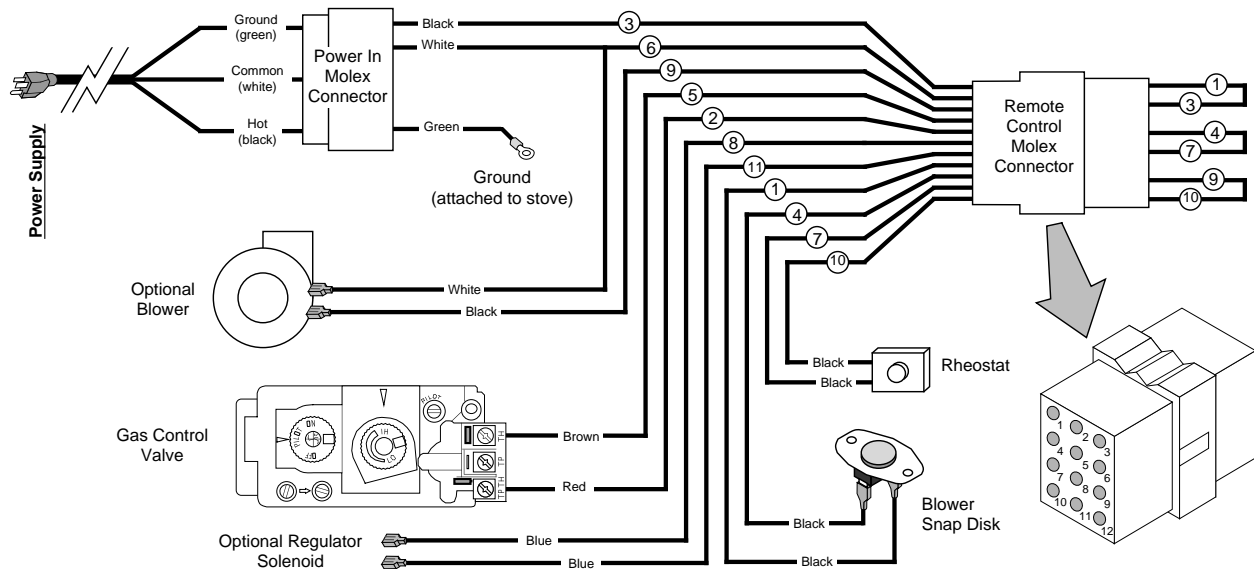



### Replacement Parts:

**Caution:** Use only Travis Industries replacement parts. Do not use substitute materials.

|  |  |  |
|--|--|--|
|  |  |  |
|--|--|--|

The listing label is shown below for your records. It can be found on the back panel.

Tested & Listed By  Beaverton Oregon USA  
OMNI-Test Laboratories, Inc.  
 Report No. 028-S-43-5



Allegiance DVS FS  
 Vented Gas  
 Fireplace Heater

Tested and certified by OMNI-Test Laboratories, Inc. to the combustion performance and construction requirements of ANSI Z21.88a-2000, and applicable sections of UL 307b.

The Allegiance is equipped from the factory only for use with Natural Gas. For conversion to LP (Propane) use kit supplied by the manufacturer. This appliance must be installed in accordance with all local codes, if any; if not, in USA follow ANSI Z223.1-1992 and NFPA 54(88). Installation in Manufactured or Mobile Homes must conform with: In USA, Manufactured Home Construction and Safety Standard, Title 24 CFR, Part 3280. This appliance is only for use with the type of gas indicated on the rating plate and may be installed in an aftermarket, permanently located, manufactured (mobile) home where not prohibited by local codes. See owner's manual for details. This appliance is not convertible for use with other gases, unless a certified kit supplied by the manufacturer is used. See owner's manual for information on making these changes. This appliance uses a millivolt-type control system consisting of a gas control valve/regulator, a standing pilot burner assembly, a thermopile, a thermocouple, a piezo ignitor, and the ON/OFF switch. **THIS UNIT DOES NOT REQUIRE 110 VOLT POWER TO OPERATE.** All exhaust gases must be vented outside the structure of the living-area. Combustion air is drawn from outside the living-area structure.

**Vented Gas Fireplace Heater. Not for use with Solid Fuel.**

**WARNING:** Improper installation, adjustment, alteration, service or maintenance can cause injury or property damage. Refer to the owner's information manual provided with this appliance. For assistance or additional information consult a qualified installer, service agency or the gas supplier.

**WARNING:** Operation of this appliance when not connected to a properly installed and maintained venting system can result in carbon monoxide (CO) poisoning and possible death.

Installation and repair should be performed by a qualified service person. The appliance should be inspected before use and at least annually by a qualified service person. More frequent cleaning may be required where excessive lint from material like carpeting and bedding is present. The control compartment, the burner compartment and all circulating air passageways of the appliance must be kept clean and clear at all times.

This appliance must be properly connected to a venting system in accordance with the manufacturer's installation instructions.

This vented gas fireplace heater is not for use with air filters.

Due to high temperatures, the appliance should be located out of traffic and away from furniture and draperies.

Children and adults should be alerted to the hazards of high surface temperature and should stay away to avoid flesh burns or clothing ignition. Young children should be carefully supervised at all times when they are in the same room as the appliance.

**CAUTION:** Hot while in operation. Do not touch. Keep children, clothing, furniture, gasoline and other liquids having flammable vapors away.

**CAUTION:** Do not operate this appliance with glass removed, cracked or broken. Replacement of the panel(s) should be done by a licensed or qualified service person.

Use direct vent systems listed in owner's manual to vent this appliance to the exterior.

---

**Minimum Clearances to Combustibles**

|                          |     |                         |        |
|--------------------------|-----|-------------------------|--------|
| Unit to Sidewall .....   | 10" | Alcove Min. Height..... | 58"    |
| Unit to Backwall .....   | 5"  | Alcove Max. Depth.....  | 45"    |
| Unit to Cornerwall ..... | 5"  | Alcove Min Width.....   | 46.75" |
| Front of Unit .....      | 36" |                         |        |

---

**FAN TYPE VENTED CIRCULATOR**  
 Blower Electrical Rating: 115V., 1.5 Amps, 60 Hz, 150 Watts

---

|                                   | <u>L.P.</u> | <u>N.G.</u> |   | <u>L.P.</u> | <u>N.G.</u> |
|-----------------------------------|-------------|-------------|---|-------------|-------------|
| Input Rate on "HI" (BTU/Hr) ..... | 31,000      | 31,000      | Minimum Inlet Pressure (inches W.C.) .....    | 11.5"       | 5.5"        |
| Input Rate on "LO" (BTU/Hr) ..... | 18,500      | 23,000      | Maximum Inlet Pressure (inches W.C.) .....    | 13"         | 7"          |
|                                   |             |             | Manifold Pressure on "HI" (inches W.C.) ..... | 11"         | 3.5"        |

In USA, this appliance is equipped for installation from 0-2000 ft. For altitudes above 2,000 feet, the vent configuration, orifice, or combination of both may need to be changed. See owner's manual for information on making these changes.

---

|             |        |        |        |        |        |  |
|-------------|--------|--------|--------|--------|--------|--|
| Manufacture | ■ 2001 | ■ Jan. | ■ Apr. | ■ Jul. | ■ Oct. | <br><small>10850 117th Pl. N.E. Kirkland, WA 98033</small> |
| Date:       | ■ 2002 | ■ Feb. | ■ May  | ■ Aug. | ■ Nov. |  |
|             | ■ 2003 | ■ Mar. | ■ Jun. | ■ Sep. | ■ Dec. |  |

0333

# Limited 7 Year Warranty

To register your TRAVIS INDUSTRIES, INC. 7 Year Warranty, complete the enclosed Warranty card and mail it within **ten (10)** days of the appliance purchase date to: TRAVIS INDUSTRIES, INC., 4800 Harbour Pointe Blvd. SW, Mukilteo, WA 98275. TRAVIS INDUSTRIES, INC. warrants this gas appliance (appliance is defined as the equipment manufactured by Travis Industries, Inc.) to be defect-free in material and workmanship to the original purchaser from the date of purchase as follows:

**Check with your dealer in advance for any costs to you when arranging a warranty call.  
Mileage or service charges are not covered by this warranty. This charge can vary from store to store.**

## Years 1 & 2 - COVERAGE: PARTS & LABOR

### Burner Assembly:

Burner Pan, Mixing Tube, Air Shutter Assembly, Main Burner Orifice

### Firebox Assembly:

Adjustable Air Restrictor, Pressure Relief Mechanisms (direct vents only), Glass Attachment Mechanism

### Gas Control Assembly

Adjustable control valve, millivolt wiring and connectors (located within the metal heater structure), thermopile, thermocouple, pilot hood, orifices, pilot gas line, piezo ignitor

### Ceramic Glass

Glass (breakage from thermal shock)

### Ceramic Logs

Log Set, Coals, Ember Strip (Steel Fiber)

### Gold Plating

Gold or Nickel Door, Optional Grill (see "Conditions and Exclusions" # 9)

### Electrical Assembly:

Blower, wiring harness, snap discs, rheostat speed control

### Accessories

Legs, Pedestal, Panels, Cast Firebacks, Shell Assembly

### Convection Heat Exchanger

### Re-Installation Allowance

In cases where heater must be removed from home for repairs, a partial cost of re-installation is covered (pre-authorization required)

### One-Way Freight Allowance

One-way freight allowance on pre-authorized repair done at factory is covered.

**Exclusions:** Paint, Gasketing

## Years 3 THROUGH 5 - COVERAGE: PARTS & LABOR

### Firebox Assembly:

Adjustable Air Restrictor, Pressure Relief Mechanisms (direct vents only), Glass Attachment Mechanism

### Convection Heat Exchanger

### One-Way Freight Allowance

One-way freight allowance on pre-authorized repair done at factory is covered.

**Exclusions:** Paint, Gasketing, Burner Assembly, Electrical Assembly, Gas Control Assembly, Ceramic Glass, Ceramic Logs, Gold & Nickel Plating, Accessories, Re-Installation Allowance

## Years 6 & 7 - COVERAGE: PARTS ONLY

### Firebox Assembly:

Adjustable Air Restrictor, Pressure Relief Mechanisms (direct vents only), Glass Attachment Mechanism

**Exclusions:** Paint, Gasketing, Burner Assembly, Electrical Assembly, Gas Control Assembly, Ceramic Glass, Ceramic Logs, Gold & Nickel Plating, Accessories, Convection Heat Exchanger, Re-Installation Allowance, One-Way Freight Allowance, Labor

## CONDITIONS & EXCLUSIONS

- This new gas appliance must be installed by a qualified gas appliance technician. It must be installed, operated, and maintained at all times in accordance with the instructions in the Owner's Manual. Any alteration, willful abuse, accident, neglect, or misuse of the product shall nullify this warranty.
- This warranty is nontransferable, and is made to the ORIGINAL purchaser, provided that the purchase was made through an authorized TRAVIS dealer.
- Discoloration and some minor expansion, contraction, or movement of certain parts and resulting noise, is normal and not a defect and, therefore, not covered under warranty. The installer must ensure the appliance is burning as per the rating tag at the time of installation. Over-firing (operation above the listed BTU rate) of this appliance can cause serious damage and will nullify this warranty.
- The warranty, as outlined within this document, does not apply to the chimney components or other Non-Travis accessories used in conjunction with the installation of this product. If in doubt as to the extent of this warranty, contact your authorized TRAVIS retailer before installation.
- Travis Industries will not be responsible for inadequate performance caused by environmental conditions such as nearby trees, buildings, roof tops, wind, hills or mountains or negative pressure or other influences from mechanical systems such as furnaces, fans, clothes dryers, etc.
- This Warranty is void if:
  - The unit has been operated in atmospheres contaminated by chlorine, fluorine or other damaging chemicals.
  - The unit is subject to submersion in water or prolonged periods of dampness or condensation.
  - Any damage to the unit, combustion chamber, heat exchanger or other components due to water, or weather damage which is the result of, but not limited to, improper chimney/venting installation.
- Exclusions to this 7 Year Warranty include: injury, loss of use, damage, failure to function due to accident, negligence, misuse, improper installation, alteration or adjustment of the manufacturer's settings of components, lack of proper and regular maintenance, damage incurred while the appliance is in transit, alteration, or act of God.
- This 7 Year warranty excludes damage caused by normal wear and tear, such as paint discoloration or chipping, worn or torn gasketing, corroded or cracked logs, embers, etc. Also excluded is damage to the unit caused by abuse, improper installation, modification of the unit, drilling of the orifices, or the use of fuel other than that for which the unit is configured. Units are shipped for natural gas and must be converted to propane using the included conversion kit. Confirm fuel configuration with your installer.
- Damage to gold, nickel, or brass surfaces caused by fingerprints, scratches, melted items, or other external sources left on the surface is not covered in this warranty. Damage from the use of cleaners other than denatured alcohol on gold or nickel is not covered in this warranty. Damage from the use of abrasive cleaners on brass is not covered in this warranty.
- TRAVIS INDUSTRIES, INC. is free of liability for any damages caused by the appliance, as well as inconvenience expenses and materials. Incidental or consequential damages are not covered by this warranty. In some states, the exclusion of incidental or consequential damage may not apply.
- This warranty does not cover any loss or damage incurred by the use or removal of any component or apparatus to or from the gas appliance without the express written permission of TRAVIS INDUSTRIES, INC. and bearing a TRAVIS INDUSTRIES, INC. label of approval.
- Any statement or representation of TRAVIS products and their performance contained in TRAVIS advertising, packaging literature, or printed material is not part of this 7 year warranty.
- This warranty is automatically voided if the appliance's serial number has been removed or altered in any way. If the appliance is used for commercial purposes, it is excluded from this warranty.
- No dealer, distributor, or similar person has the authority to represent or warrant TRAVIS products beyond the terms contained within this warranty. TRAVIS INDUSTRIES, INC. assumes no liability for such warranties or representations.
- Travis Industries will not cover the cost of the removal or re-installation of hearths, facing, mantels, venting or other components.
- If for any reason any section of this warranty is declared invalid, the balance of the warranty remains in effect and all other clauses shall remain in effect.
- THIS 7 YEAR WARRANTY IS THE ONLY WARRANTY SUPPLIED BY TRAVIS INDUSTRIES, INC., THE MANUFACTURER OF THE APPLIANCE. ALL OTHER WARRANTIES, WHETHER EXPRESS OR IMPLIED, ARE HEREBY EXPRESSLY DISCLAIMED AND PURCHASER'S RECOURSE IS EXPRESSLY LIMITED TO THE WARRANTIES SET FORTH HEREIN.**

## IF WARRANTY SERVICE IS NEEDED:

- If you discover a problem that you believe is covered by this warranty, you MUST REPORT it to your TRAVIS dealer WITHIN 30 DAYS, giving them proof of purchase, the purchase date, and the model name and serial number.
- Travis Industries has the option of either repairing or replacing the defective component.
- If your dealer is unable to repair your appliance's defect, he may process a warranty claim through TRAVIS INDUSTRIES, INC., including the name of the dealership where you purchased the appliance, a copy of your receipt showing the date of the appliance's purchase, and the serial number on your appliance. At that time, you may be asked to ship your appliance, freight charges prepaid, to TRAVIS INDUSTRIES, INC. TRAVIS INDUSTRIES, INC., at its option, will repair or replace, free of charge, your TRAVIS appliance if it is found to be defective in material or workmanship within the time frame stated within this 7 year warranty. TRAVIS INDUSTRIES, INC. will return your appliance, freight charges (years 1 to 5) prepaid by TRAVIS INDUSTRIES, INC., to your regional distributor, or dealership.
- Check with your dealer in advance for any costs to you when arranging a warranty call. Mileage or service charges are not covered by this warranty. This charge can vary from store to store.

## LP Conversion Instructions

**Install the conversion kit prior to installing the gas line to ensure proper gas use.**

- 1 Open the door (page 16) and remove the glass (page 14). Remove the logs and coals (page 15)
- 2 Remove the burner (see illustration below).

Reach into the firebox and slide the burner to the left then lift it upwards (lift the burner from below).

Do not lift the burner from the pins.

**WARNING:**

The burner is fragile - handle it with care.

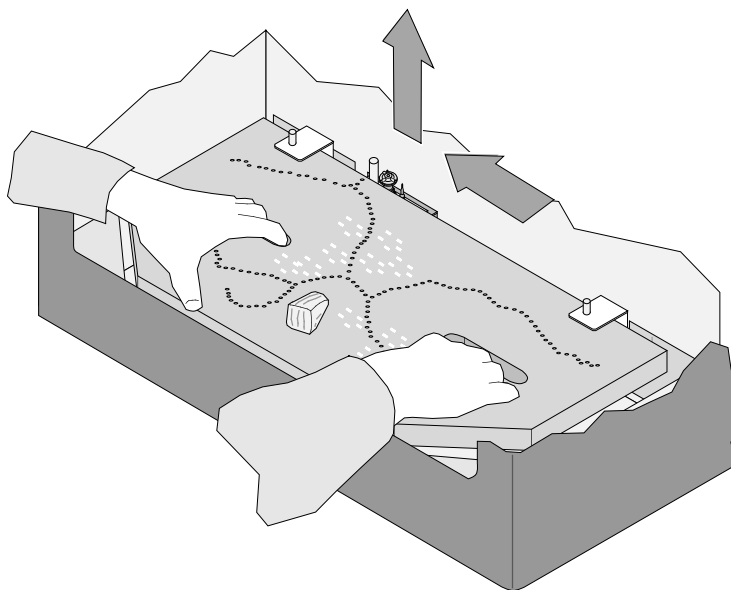

**Replacement Notes:**

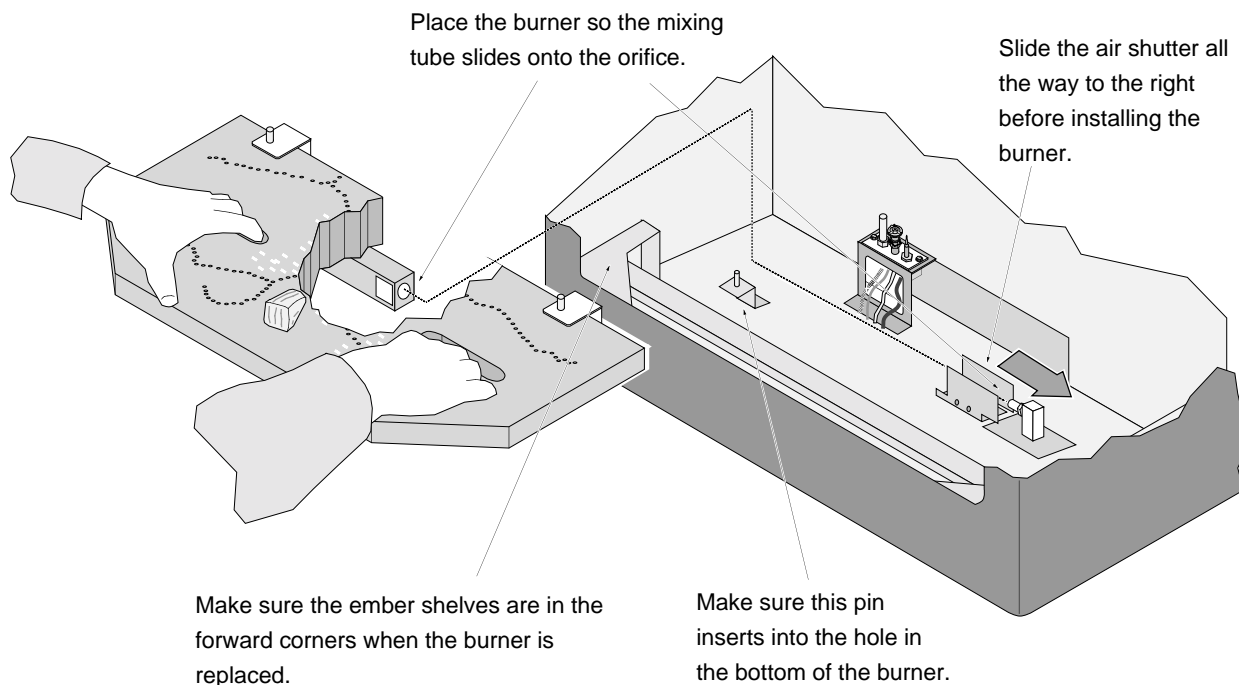



# 32 Optional Equipment (Qualified Installers Only)

3 Follow the directions below to replace the natural gas orifice.

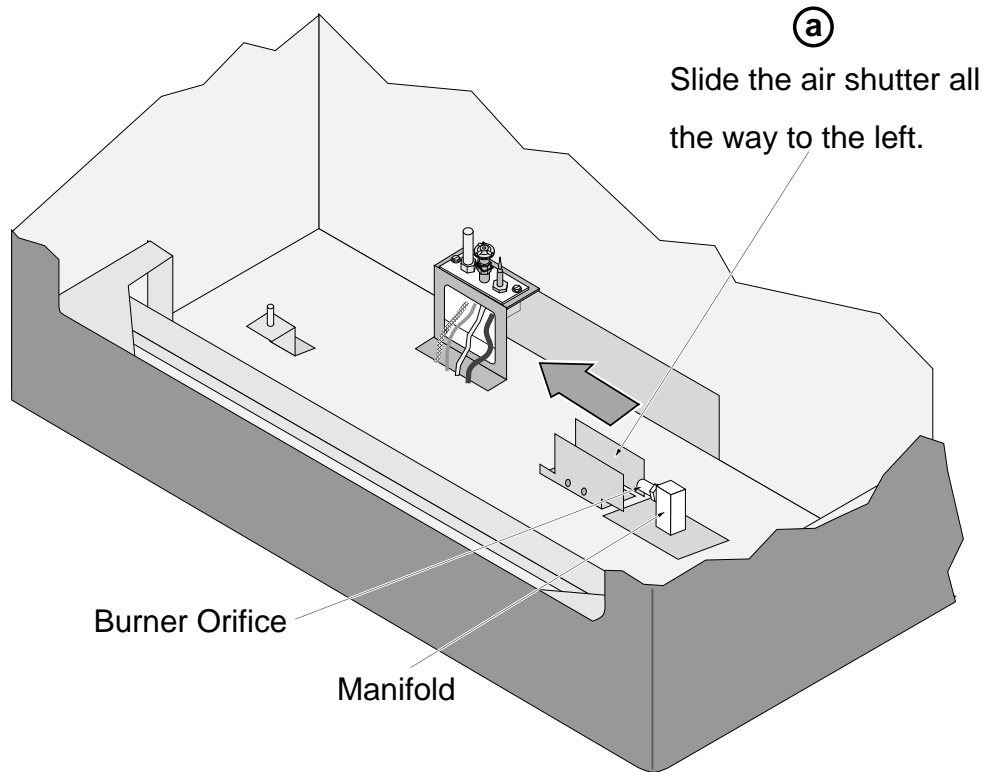

**d** Use a 1/2" open end wrench to unscrew the burner orifice.

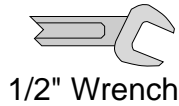
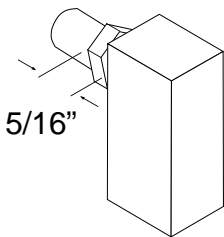

1/2" Wrench

**NOTE:** Screw the LP orifice in so the orifice shoulder protrudes 5/16" (indicating full insertion).

The new LP orifice is .0625" it has ".062" stamped on it.

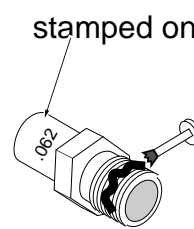

**e** Apply thread sealant to the new orifice and install.

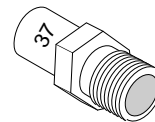

The old NG orifice has "37" stamped on it.

**4** Remove the pilot orifice following the instructions below. Replace with the propane pilot orifice

**(a)** Lift the pilot hood off the pilot assembly.

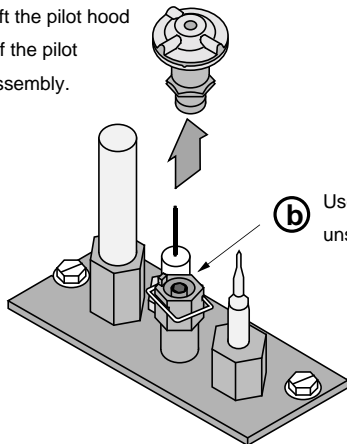

**(b)** Use a hex wrench to unscrew the orifice.



**(c)** Remove the orifice and replace with the LP orifice. Screw the orifice all the way in and replace the pilot hood.

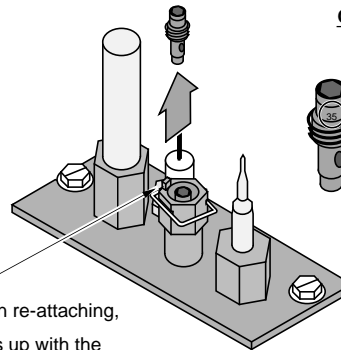

**Orifice Identification:**

- LP (Propane) Orifice 35
- NG (Natural Gas) Orifice 62

**NOTE:** when re-attaching, this pin lines up with the notch in the pilot hood.

**5** Remove the regulator from the front of the gas control valve. Replace with the propane regulator, using the new gasket and screws included with the regulator. **NOTE: Leak test this area after the heater is installed, gas is connected, and the main burner is lit.**

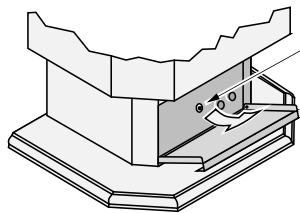

**(a)** To access the gas control valve, pull on the piezo igniter to open the access panel and expose the gas control valve.

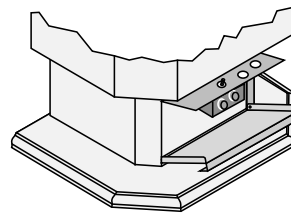

**(b)**

Remove and discard the three screws using a slotted screwdriver of Torx T-20.

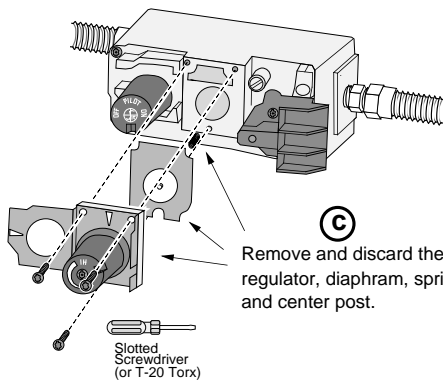

**(c)** Remove and discard the regulator, diaphragm, spring and center post.



**(d)**

Install the LP regulator. Use the screws included with the LP regulator. Tighten to approximately 25 Lbs. torque.

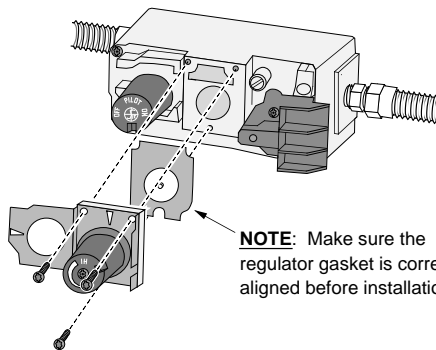

**NOTE:** Make sure the regulator gasket is correctly aligned before installation.

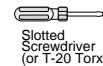

**(e)**

Place the LP label on top of the control cover near the gas control valve.

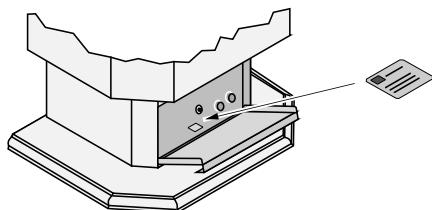

# 34 Optional Equipment (Qualified Installers Only)

- 6 Make the gas line connection, bleed the gas line (if applicable), start the heater and thoroughly leak-test all gas connections and the gas control valve. Check the pilot. Adjust if necessary.

**WARNING: When lighting or re-lighting the pilot, the glass must be removed (see page 21).**

To adjust the pilot flame, turn this screw (NOTE: if totally unscrewed gas will come out of this port). Clockwise lowers the flame while counter-clockwise raises it.

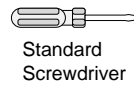

The pilot flame must contact the thermocouple and thermopile (see the illustration below). Adjust the pilot up or down as necessary.

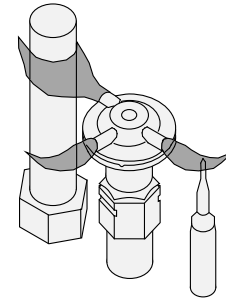
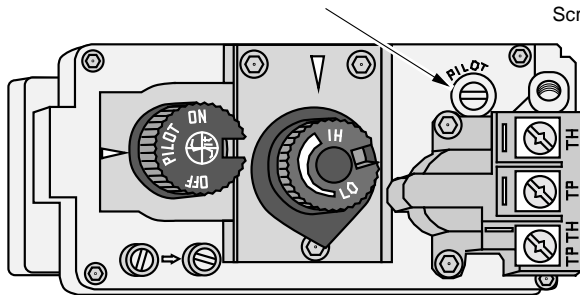

- 7 Install the log set (see page 22).
- 8 Replace the glass and face (see page 21).

## ***Blower (part # 99000153)***

**WARNING:** Turn the gas control valve to off and make sure the appliance has fully cooled prior to conducting service.

- 1 Attach the two black wires at the rear right of the stove to the thermodisk (orientation does not matter). Then slide the thermodisk into the holder underneath the burner pan.

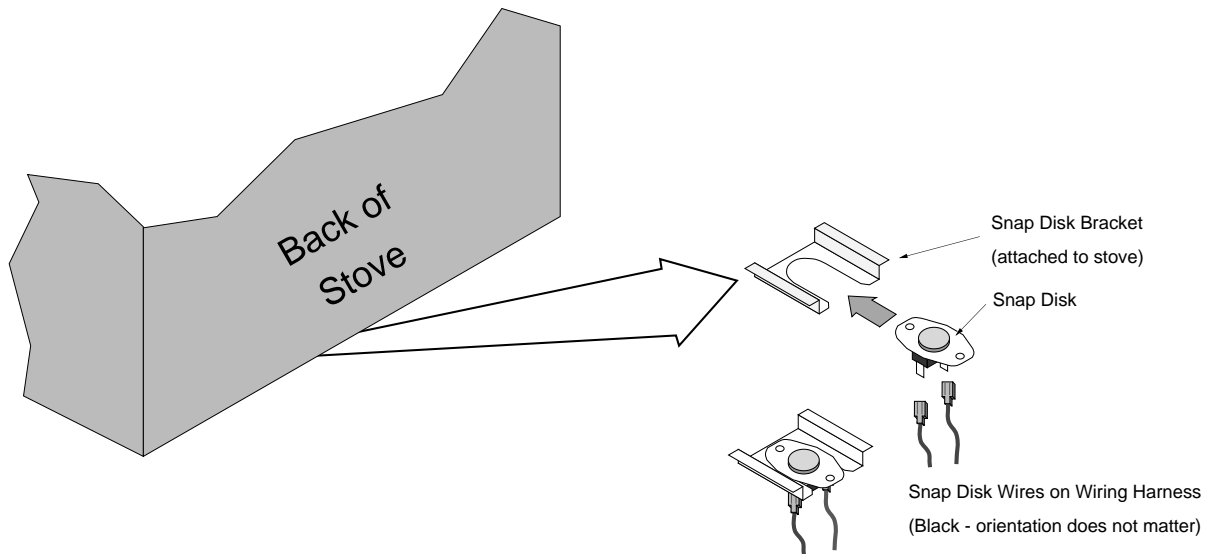

- Place the blower near the rear of the stove. Attach the wiring in grommets following the directions below.

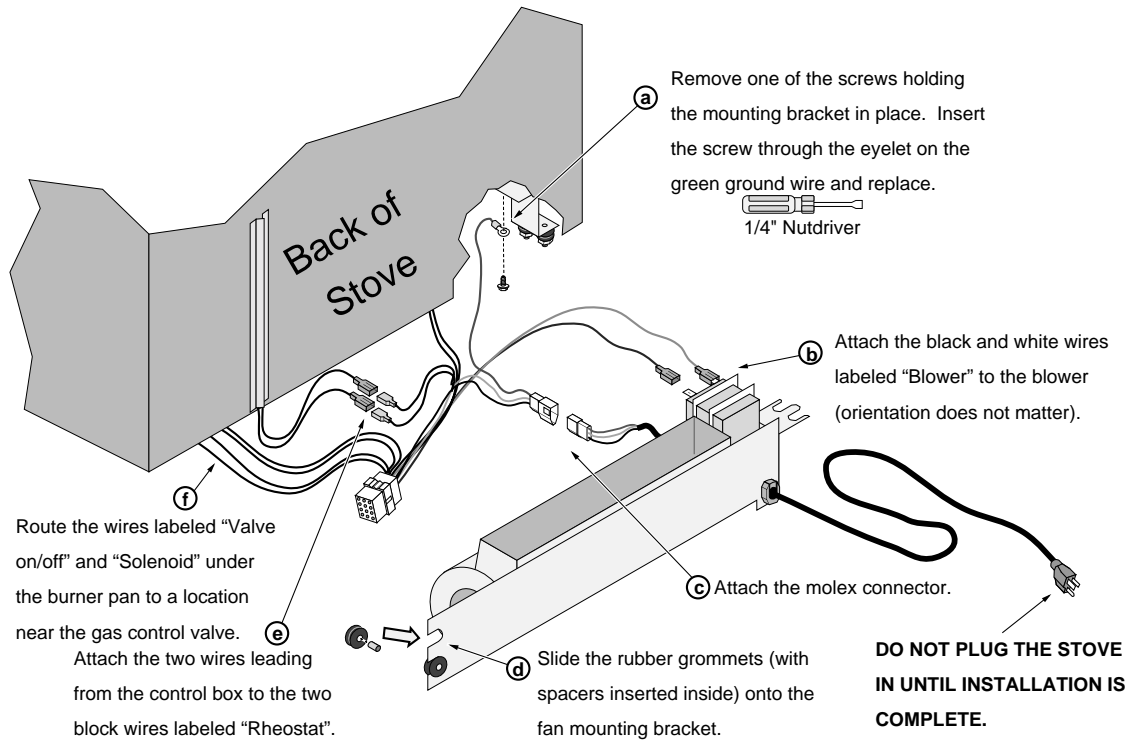

- Slide the left side of the blower mounting bracket over the grommets on the left mounting bracket attached to the stove (see the illustration below). Then insert the stud plate through the right side grommets and through the right mounting bracket on the stove. Secure the stud plate with the included washers and nuts

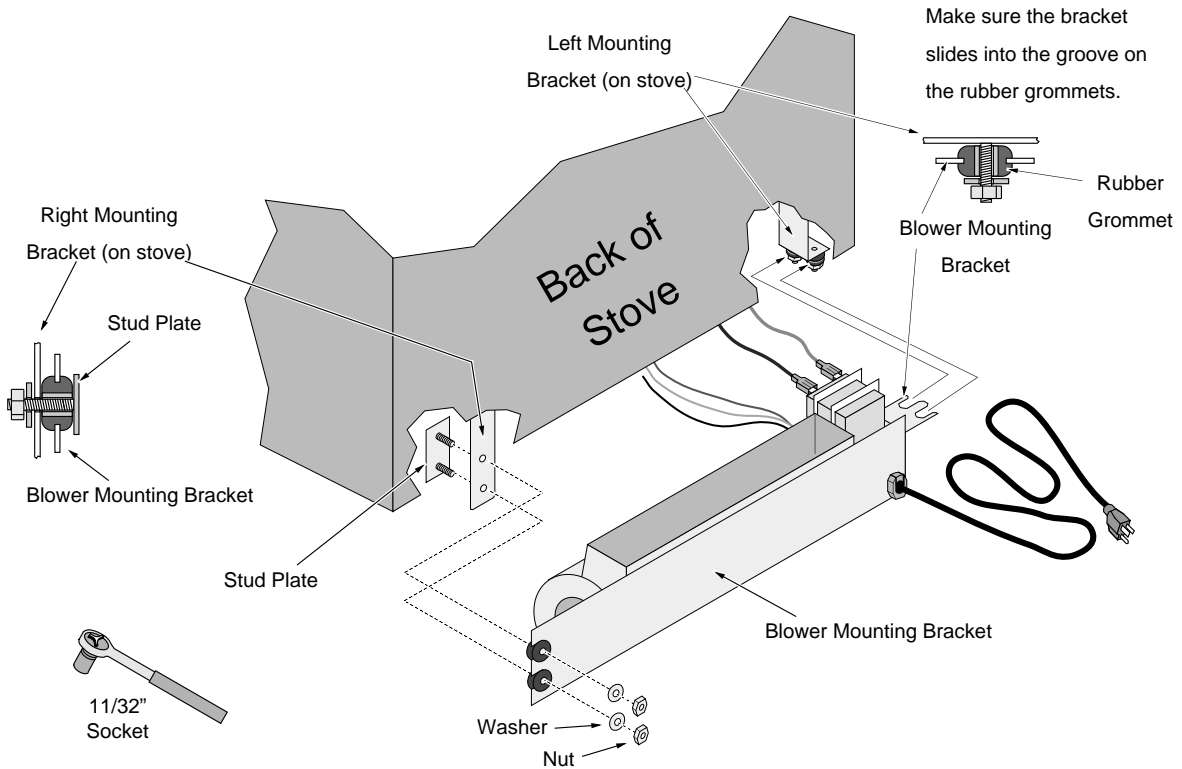

## 36 Optional Equipment (Qualified Installers Only)

- 4 Make sure all of the wiring is placed away from the blower impeller and the bottom of the burner. Use lock ties, if necessary, to ensure no wires are damaged.
- 5 Open the control cover following the directions below. Remove the button plug and install the rheostat.

1. Remove the two 3/8" nuts from the corner plate cover with 3/8" nut driver.

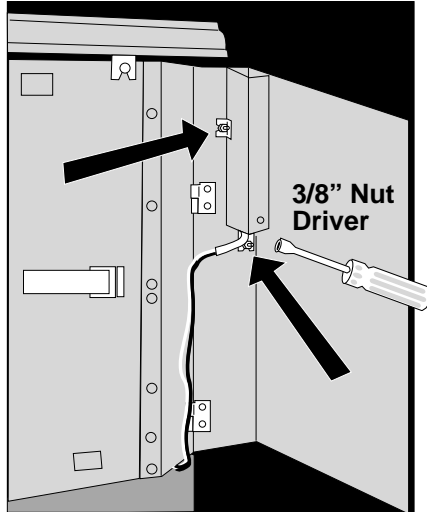

2. Attach the rheostat to the two quick connects inside the cover. (orientation does not matter).

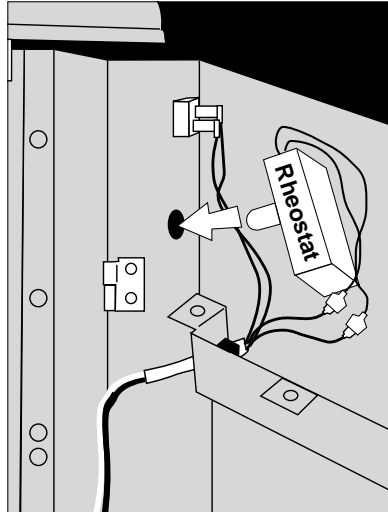

3. Attach the rheostat to the panel with included nut and washer. Tighten with 1/2" wrench.

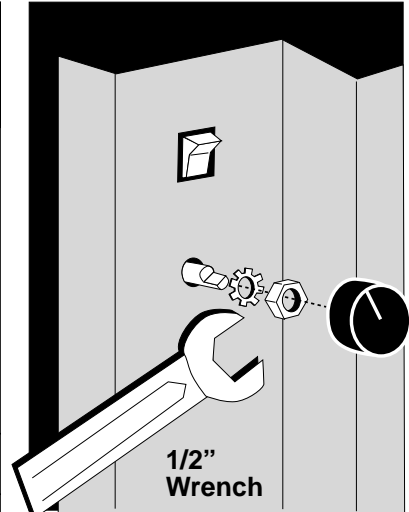

- 6 Plug the blower in. Let the heater achieve operating temperature and test blower operation.

### Gold Door (part # 99300523)

Follow the directions to the right to install the optional gold door.

#### WARNING:

Clean the gold surface prior to starting the stove. Any marks left on the gold may become etched-in by the heat of the stove. Use denatured alcohol and a soft cloth to clean.

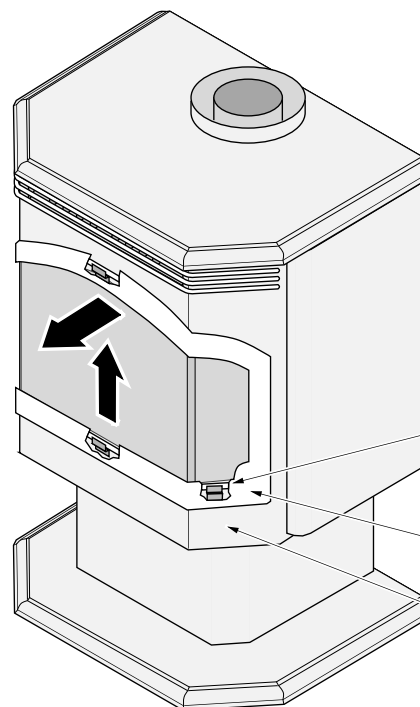
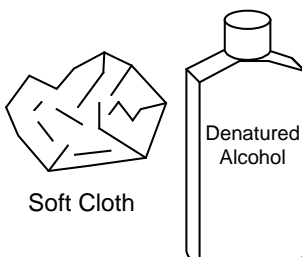

Remove the black door by sliding it up and off the door frame.

Slide the gold door onto the door frame.

**HINT:** align the bottom joggle clips over the brackets on the door and slide into place. Then lift up slightly on the door to attach the upper clips.

The door is held in place with four joggle clips.

Door

Door Frame

## Gold Grill (part # 93005034)

Follow the directions below to install the optional gold grill.

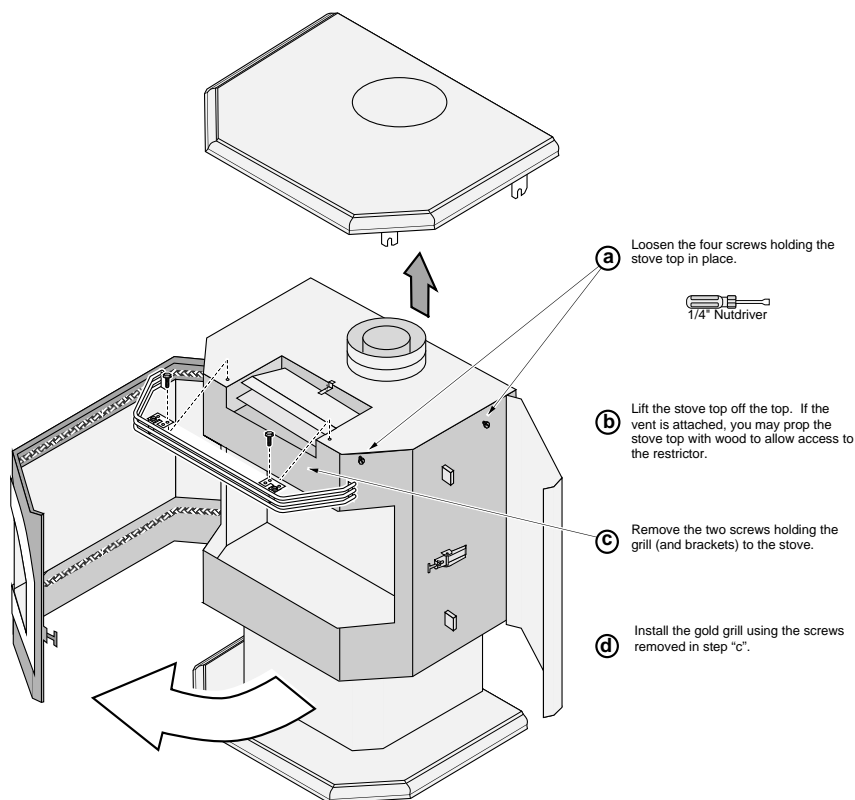

## Fireback (part # 99900145)

Follow the directions below to install the fireback.

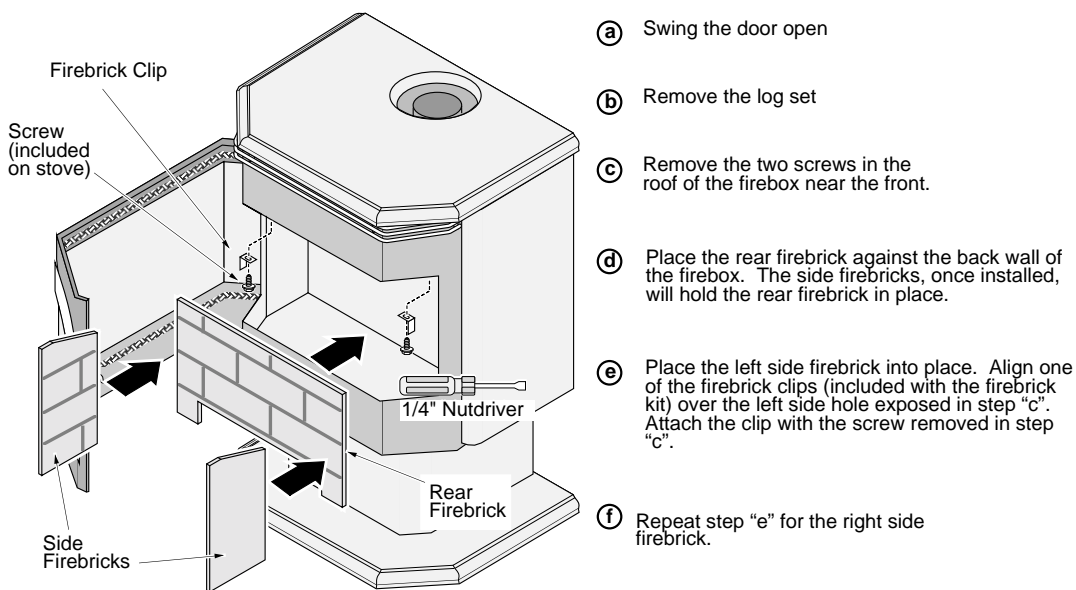

### ***ADDENDUM #1 Interior Masonry Chimney Conversions***

- Follow the requirements and use the equipment listed in the illustration to the right to install this appliance into an interior masonry chimney.
- Maximum vertical rise is 30'
- Minimum vertical rise is 10'
- Use the following restrictor positions:
  - Position 2 for heights between 10' and 14'
  - Position 3 for heights between 14' and 22'
  - Position 4 for heights between 22' and 34'

**NOTE:** these restrictor positions are based upon lab tests. The ideal restrictor position may vary slightly.

**The entire chimney system must be air-tight. Make sure to seal the flashing, clean-out, and thimble connection, and to inspect the chimney.**

Make sure the coaxial pipe maintains a 1" clearance to any combustible. The vent must be sealed air-tight.

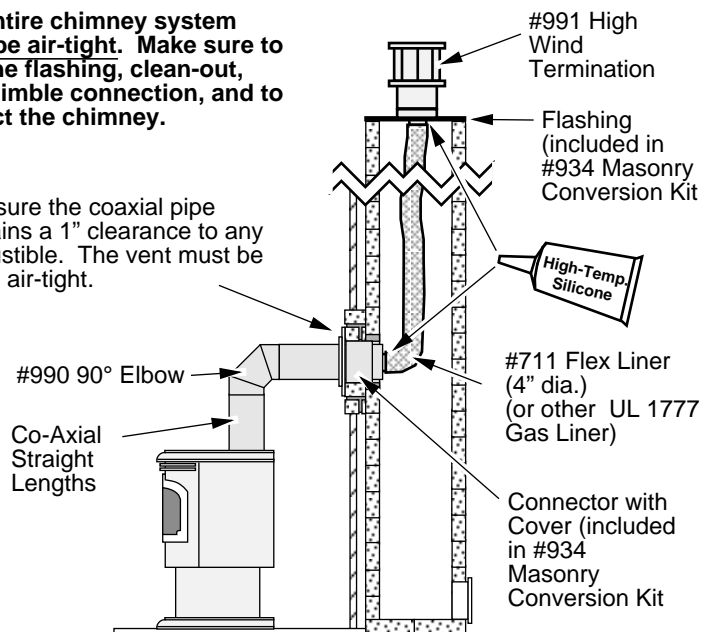

## ADDENDUM #2 Class A Chimney Conversion Kit

Simpson DuraVent provides a conversion kit for those wishing to use an existing wood stove chimney to vent this direct vent stove. The illustration below gives an overview of this type of installation. See the instructions included with the kit for details.

**Warning** The conversion kit does not work on interior masonry chimneys.

**Warning** Do not exceed the maximum vertical rise (see the section “Approved Vent Configurations” starting on page 9) allowable. Remember to set the restrictor position to the correct position (based upon the vertical rise height - see the chart on page 10).

### Chimney Conversion Kit A (# 931)

Metalbestos 6" (150 mm) I.D.  
 Security Chimneys 6" (150 mm) I.D.  
 Jackes-Evans 6" (150 mm) I.D.  
 Hart & Cooley 6" (150 mm) I.D.  
 Pro-Jet 6" (150 mm) I.D.

### Chimney Conversion Kit B (# 932)

Simpson Dura-Vent 6" (150 mm) I.D.  
 Air-Jet 6" (150 mm) I.D.  
 Metal-Fab 6" (150 mm) and 7" (175 mm) I.D.  
 Amer. Metals 6" (150 mm) & 7" (175 mm) I.D.  
 Metalbestos 7" (175 mm) and 8" (200 mm) I.D.  
 Jackes-Evans 7" (175 mm) and 8" (200 mm) I.D.  
 Hart & Cooley 7" (175 mm) and 8" (200 mm) I.D.  
 Pro-Jet 7" (175 mm) and 8" (200 mm) I.D.  
 Security Chimneys 8" (200 mm) I.D.

### Chimney Conversion Kit C (# 933)

Simpson Dura-Vent 7" (175 mm) and 8" (200 mm) I.D.  
 American Metals 8" (200 mm) I.D.  
 Air-Jet 8" (200 mm) I.D.  
 Metal-Fab 8" (200 mm) I.D.  
 American Metals 8" (200 mm) I.D.

### Each Kit Contains:

Retro Connector  
 Retro Vertical Top

### Additional Equipment Required:

Termination (#991)  
 4" Flex (#711 or U.L. 1777)  
 Co-Axial Sections

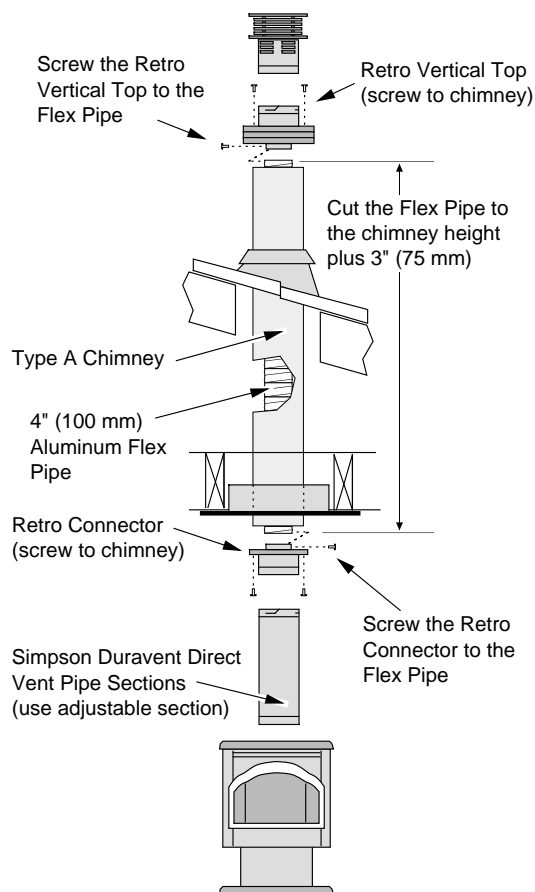



|   |                    |  |    |
|---|--------------------|--|----|
| Adjusting the Blower Speed.....               | 24                 | Lifting Flames.....                              | 18 |
| Adjusting the Flame Height .....              | 23                 | Listing Label (Safety Label) .....               | 29 |
| AFUE.....                                     | 5                  | Log Installation .....                           | 20 |
| Air Shutter Adjustment.....                   | 17                 | Maintaining Your Stove's Appearance.....         | 25 |
| Alcoves.....                                  | 7                  | Natural Gas Verses Propane.....                  | 2  |
| Altitude Considerations.....                  | 8                  | On/Off Operation.....                            | 23 |
| Amperage (of blower).....                     | 5                  | On/Off Switch (Location).....                    | 21 |
| Blower Speed .....                            | 24                 | Operating Sounds.....                            | 24 |
| BTU Output.....                               | 5                  | Order of Installation .....                      | 6  |
| Burn Rate.....                                | 5                  | Packing Lists.....                               | 6  |
| Burner Installation.....                      | 31                 | Paint Curing .....                               | 23 |
| Cap (vent termination).....                   | 16                 | Pilot (starting) .....                           | 22 |
| Cleaning Your Heater.....                     | 25                 | Pilot Flame (Location).....                      | 21 |
| Clearances.....                               | 6                  | Pressure (of gas) .....                          | 7  |
| Condensation .....                            | 23                 | Purging Gas Line (with door open).....           | 17 |
| Controls.....                                 | 21                 | Remote Control Thermostat Installation.....      | 38 |
| Dimensions.....                               | 5                  | Required Components for Installation .....       | 6  |
| Door Opening .....                            | 19                 | Restrictor Adjustment .....                      | 9  |
| Efficiency.....                               | 5                  | Safety Label.....                                | 29 |
| Elbows.....                                   | 9                  | Safety Precautions .....                         | 2  |
| Electrical Specifications.....                | 5                  | Silicone Vent Sections.....                      | 8  |
| Emissions .....                               | 5                  | Snorkel Terminations.....                        | 8  |
| Flame Height.....                             | 23                 | Sounds.....                                      | 24 |
| Floor Protection Requirements.....            | 7                  | Starting The Pilot Flame .....                   | 22 |
| Fuel.....                                     | 5                  | Starting the Heater for the First Time .....     | 23 |
| Fumes (if you smell gas See Inst. on Cover).. | 23                 | Stove Placement Requirements.....                | 7  |
| Gas Control Valve (Location).....             | 21                 | Table of Contents.....                           | 4  |
| Gas Inlet Installation .....                  | 7                  | Troubleshooting Table.....                       | 26 |
| Gas Leak.....See Inst. on Cover               |                    | Vent Configurations.....                         | 9  |
| Gas Line Connection .....                     | 7                  | Vent Part #'s.....                               | 8  |
| Gas Smell.....See Inst. on Cover              |                    | Vent Requirements .....                          | 8  |
| Heating Capacity.....                         | 5                  | Vertical Vent Termination Requirements .....     | 16 |
| High Wind Vertical Terminations.....          | 16                 | Warranty.....                                    | 30 |
| Horizontal Vent Termination Requirements ..   | 16                 | Water (on glass - see starting the heater) ..... | 23 |
| How to Measure Vent Lengths .....             | 9                  | Wiring Diagram.....                              | 28 |
| Installation Options .....                    | 5                  | Yearly Service Procedure.....                    | 25 |
| Installation Preparation.....                 | 6                  |  |    |
| Leaking Gas .....                             | See Inst. on Cover |  |    |