

OWNER'S MANUAL

LOPI FIREPLACE INSERT

MODEL X

INSTALLATION, OPERATION AND MAINTENANCE HANDBOOK

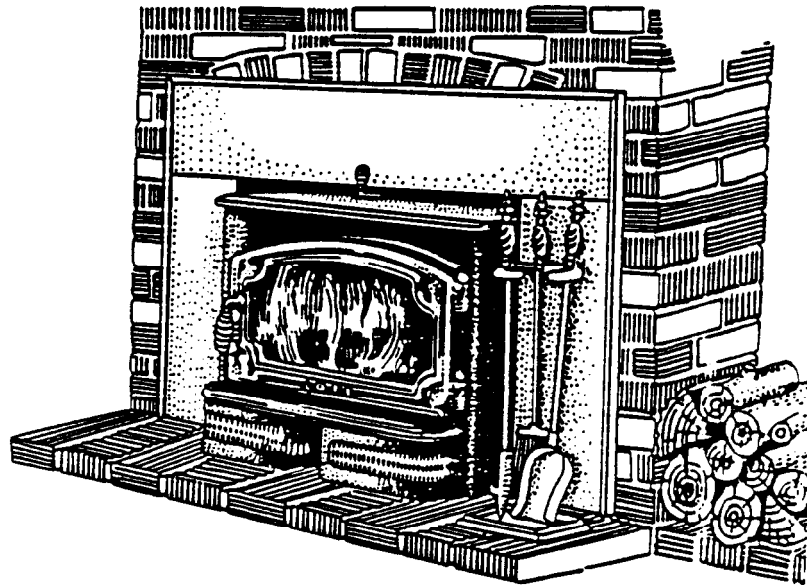

JUNE 1988

Tested to UL 907 (U.S.A.) ULC S628 (Canada)

We welcome you as a new owner of a LOPI wood heating appliance. In purchasing a LOPI, you have joined the growing ranks of concerned individuals whose selection of an energy system reflects both a concern for efficiency and aesthetics.

We offer our continual support and guidance to help you achieve the maximum benefit and enjoyment from your wood heating appliance.

You are encouraged to familiarize yourself with the Owner's Manual before installing your wood heating appliance. This manual covers in detail the necessary steps required in assembling and installing your wood heating appliance to meet all safety codes. Included are helpful hints and suggestions which will make the installation of your new stove or insert an easier and more enjoyable experience.

We at LOPI wish you many years of warmth and satisfaction.

PREPARATION:

Please record the insert serial number located on the side of the unit, before installing.

RECORD SERIAL NUMBER HERE _____ .

Installing your insert requires some preparation and homework. It is very important to learn your local building codes. You may be required to obtain a building permit before installing your insert. Your local Building Inspection Department will be happy to assist you with information regarding installation and safety requirements in your area. Also, notify your home insurance company that you plan to install a fireplace insert. Before using the insert, be sure to have a local Building Inspector approve your installation in writing.

LOPI inserts are intended for installation in accordance with the Standards for Chimney Fireplaces and Vents NFFA No. 211.

You should inspect your fireplace for good integrity throughout the system. There should be no missing bricks, mortar, cracks or heavy deposits of creosote. It is recommended that your fireplace be cleaned and inspected by a professional chimney sweep before installing your stove.

NOTE: DO NOT CONNECT THE INSERT TO A CHIMNEY SYSTEM SERVING ANOTHER APPLIANCE OR AIR DISTRIBUTION DUCT.

NOTE: LOCK EXISTING FIREPLACE DAMPER IN "OPEN" POSITION BEFORE INSTALLING INSERT.

Certain regions also require a direct flue connection for insert installation. For increased heating efficiency we recommend a direct flue connection, however all LOPI inserts have been tested and approved with or without the use of a direct flue connection.

Your LOPI fireplace insert will come packaged in several boxes. These will include:

1. STOVE MASTER BOX - Includes the stove firebox. Door with handles, firebrick, baffle, hardware kit, manual, and ashlip.
2. GLASS BOX - Includes one piece of glass for the single door and non-asbestos fiberglass gasketing.
3. PANEL BOX - Includes two side panels, one top panel with Brass Trim and Hardware.

Accessories available through your local LOPI dealer. These optional packages include:

1. Reduced clearance mantle shield
2. Etched glass.

WARNING: CARELESS INSTALLATION IS THE MAJOR CAUSE OF SAFETY HAZARDS. CHECK ALL LOCAL BUILDING AND SAFETY CODES BEFORE INSTALLATION OF THE UNIT.

Your fireplace insert is very heavy and requires at least two people to move it safely. The insert can be damaged by mishandling. Before installing, check and clean your masonry chimney system thoroughly. If in doubt about its condition, seek professional advice from your authorized LOPI dealer or certified chimney sweep.

DEALERS ARE TRAINED TO SAFELY INSTALL UNITS AND IT IS A CHOICE WE HIGHLY RECOMMENDED.

WARNING: DO NOT REMOVE BRICK OR MORTAR FROM EXISTING FIREPLACE TO INSTALL UNIT. IT IS NECESSARY TO PERMANENTLY SEAL ANY OPENING BETWEEN THE MASONRY OF THE FIREPLACE AND THE MASONRY FACING.

NOTE: DO NOT INSTALL IN A ZERO CLEARANCE FIREPLACE!! INSTALL AND USE ONLY IN ACCORDANCE WITH THESE INSTRUCTIONS.

INSTALLATION:

Installation into a masonry fireplace requires a minimum chimney height of 15' (fifteen feet) and from a minimum inside flue cross-sectional area of 64"SQ/IN. to a maximum inside flue cross-sectional area of 120"SQ/IN.

If your chimney liner exceeds 120SQ/IN you will be required to install a direct flue connector, please consult your dealer for information on direct flue connections.

NOTE: (DFC) REQUIRED FOR ALL INSERT INSTALLATIONS IN CANADA.

NOTE: COMPLETELY RELINING THE CHIMNEY SHOULD BE CONSIDERED WITH LARGE CHIMNEY FLUE SYSTEMS (SYSTEMS THAT EXCEED 120SQ/IN). THIS WILL AID IN MAINTAINING A CONSISTENT DRAFT WHICH GREATLY IMPROVES THE PERFORMANCE OF THE UNIT.

To make the installation of your fireplace insert easier, please read all instruction before installing and using your stove.

TOOLS NEEDED: Standard screwdriver, tape measure, pliers, level, gloves, 1/2" open end wrench and pencil.

FLOOR PROTECTION:

Floor protection of fireplace hearth must meet the standards required for clearances to combustibles.

The non-combustible material (raised or flush) should extend at least:

A = 18" (455mm) in front of the insert loading doors.

B = 8" (205mm) to both sides of the insert.

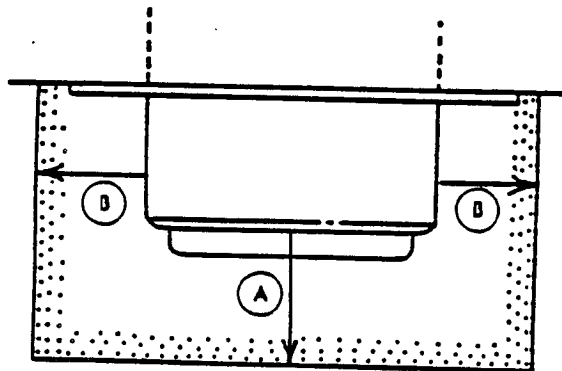

The stove requires a non-combustible hearth extension of 18" (455mm) from the front of the unit, and 8" (205mm) to both sides. If you do not have a non-combustible hearth or your existing hearth does not meet these minimum requirements, you will be required to install a fireproof non-combustible hearth extension or pad.

CLEARANCES TO COMBUSTIBLES:

Before installing your insert, make sure that your fireplace meets the clearances to combustibles requirements listed below. FAILURE TO INSTALL YOUR INSERT TO THESE CLEARANCES MAY PRESENT A SERIOUS FIRE HAZARD.

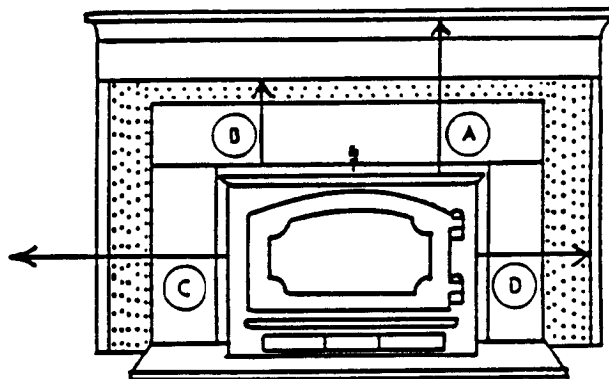

MODEL X INSERT

A = To Mantle	29" (736mm)
B = To Top Facing	25" (635mm)
C = Sidewall	23" (584mm)
D = Side Facing	15" (381mm)
E = Any Room Combustible	36" (914mm)

MANTLE CLEARANCE REDUCTION:

Clearances to the combustible mantle or top facing can be reduced with the use of LOPI's Mantle Reduction Shield.

MODEL X - Combustible Mantle or Top Facing = 19" (483mm).

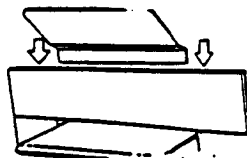

To install, simply pull the top panel gently away from the fireplace and place the mantle shield behind the panel. The force of the panel against the fireplace will hold the mantle shield in place.

With the use of this mantle shield you have now achieved a reduced clearance to mantle or top facing.

INSTALLATION OF INSERT INTO FIREPLACE:

LEVELING BOLTS

If your fireplace is stepped down from the hearth, you will need to utilize the leveling bolts included in the hardware package.

These bolts screw into the welded nuts located underneath the firebox near the back edge. You will need to tilt the unit back and screw the leveling bolts through the bottom into the weld nut. Measure the distance that your fireplace floor drops from the hearth and adjust the leveling bolts to this height.

With the help of at least one other person, lift the insert and place it about half way into the fireplace opening.

You may have to further adjust the leveling bolts at this time.

FACING PANELS/INSULATION INSTRUCTIONS:

Panels are provided in various sizes to frame the insert, and together with the insulation are designed to make the fireplace airtight from the room. These panels must extend at least 2" (50mm) beyond the fireplace opening

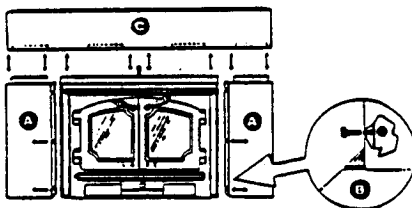

1. Align side panels (A) with the sides of the convection chamber. BE SURE that the inside panel flange (the side with the notch) fits INSIDE the convection chamber, not butted up to the outside.
2. Align holes and install bolts from the inside of the convection chamber. (B) Secure nuts to bolts and tighten. Due to the limited space, it is advisable to use a dime to tighten the screw while the nut is held in place.
3. Once side panels are secured, position the top panel (C) over the stove. Now align clips and slide over side panel flanges and the top of the stove heat chamber. Press down firmly for a secure fit.

Panel trim should be installed now

1. Place trim face down on the floor as it would appear on the insert.
2. Place corner brackets in appropriate slots. Small corner brackets go to the front face of the trim, large corner brackets with screw holes go in back.
3. Once in place, insert set screws and firmly secure with provided allen wrench.
4. Slide completed trim over panels. You may wish to use two sided tape at the ends of the trim to hold it firmly against the bottom of the side panels.

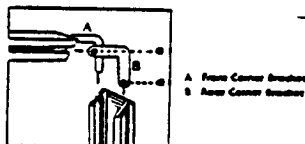

To make the fireplace airtight, remove thick wide strip of insulation that was included inside the firebox. Attach the insulation on the backside of the panels, completely around the outside perimeter, allowing a little of the insulation to stick out past the panel edge.

Now, slide your insert in so that the panels are flush to the fireplace opening, being careful not to scratch the hearth underneath.

With a screwdriver, tuck the exposed insulation behind the panels for an airtight fit. Check for a good seal by holding a match around the perimeter of the facing panels to determine if any drafts are occurring. If so fill the spot with more insulation and re-check.

FIREBRICK FLOOR LAYOUT:

For your convenience, the firebrick has been installed the factory to protect and extend the life of the steel and to help radiate heat evenly throughout the stove.

MODEL X

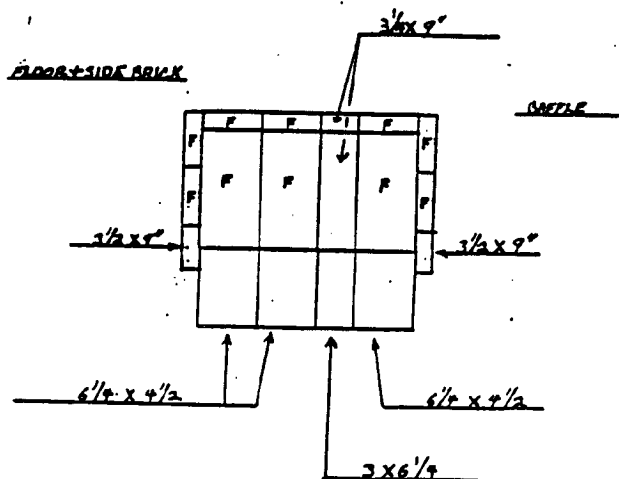

MASONRY BAFFLE INSTALLATION:

The masonry baffle is designed to retain and ignite unburned volatile gases that would otherwise escape up the flue. This results in high efficiency, low particulate emissions and greater heat transfer.

DO NOT OPERATE INSERT WITHOUT THE BAFFLE IN PLACE, DOING SO CAN RESULT IN AN UNSAFE OPERATING CONDITION AND VOID YOUR WARRANTY.

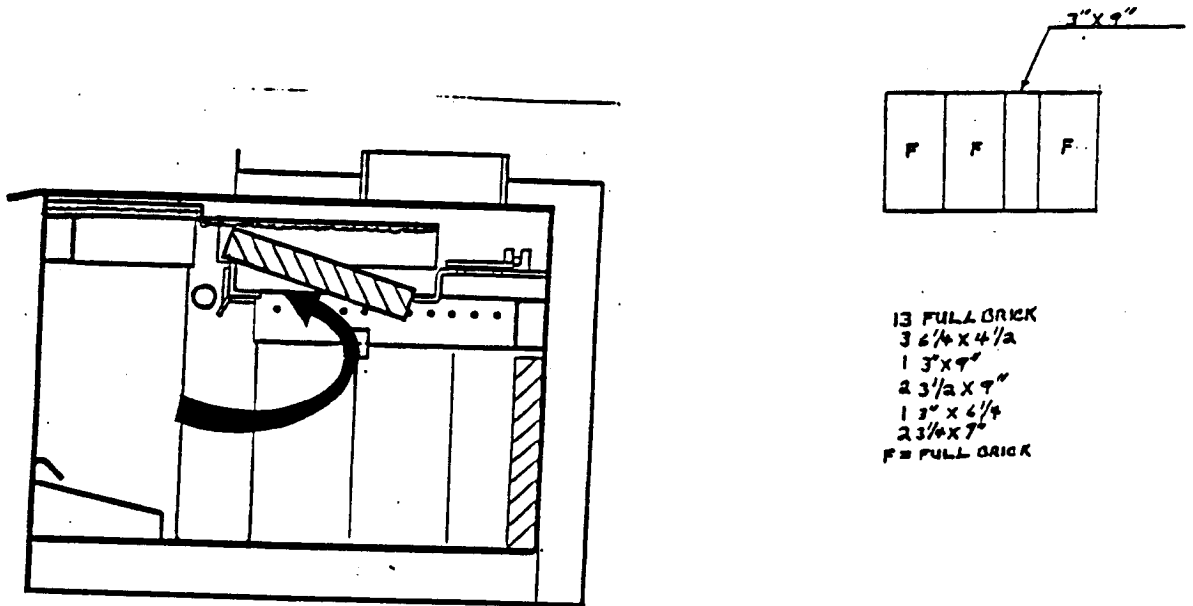

GLASS INSTALLATION:

Read all instructions before starting.

1. Glass Gasketing:

CENTER AND WRAP AROUND GLASS

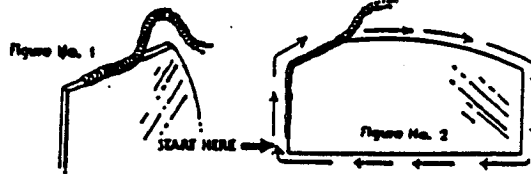

- A. From glass kit box, remove the glass and gasketing material.
- B. The gasketing is provided to ensure a proper airtight seal between the glass and the door.
- C. To attach the gasketing material, simply remove the paper backing, center and wrap around the edge of the glass.
- D. When applying gasketing material, always start on the outside lower corner (Figure 2). This will ensure that the frayed ends will not be visible when the doors are installed.
- E. Trim off any excess material.

INSTALLING GLASS IN DOOR:

First, remove door from stove by lifting up, pulling door off hinges. Remove door handle from door next remove inner door retainer

To install glass and reassemble door.

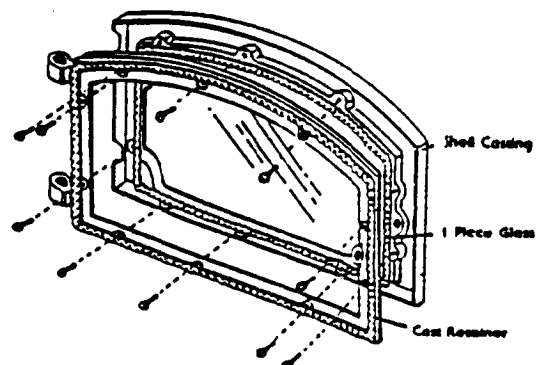
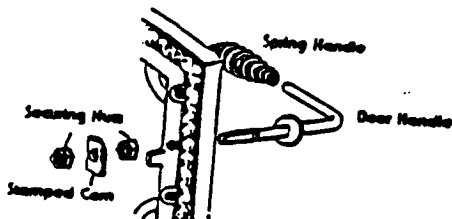

1. Place the cast retainer face down so the hinges face out to the right side (see illustration). Next place the gasketed glass into the cast retainer. If the glass is etched, the etched surface is facing out toward you. The glass fits snugly within the recesses of the cast retainer.

2. Next position the door shell over the top of the glass and retainer. Once the shell has been positioned over the glass and retainer, squeeze all three pieces tightly together with both hands and gently flip over. Be careful not to dislodge any of the pieces.

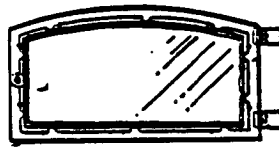

3. Once the door parts have been flipped over, adjust the cast retainer so the securing holes on the retainer align with those on the shell. Secure the door, glass and retainer together with the 10 self-tapping screws. Tighten screws in the configuration shown. Tighten the screws in an even manner to ensure equal distribution of pressure on the glass. Failure to do so could result in glass breakage.

4. Once the door is assembled, place the hinge pins into the door and hang the door onto the face of the stove.

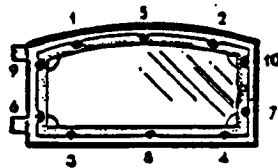

5. Finally assemble the door handle. To do this, first swing the door open and run the door handle through the handle hole in the door. Next take one of the securing nuts and tighten it down with your hand until snug. Then place the cam over the shaft as shown and tighten remaining nut down on door handle shaft.

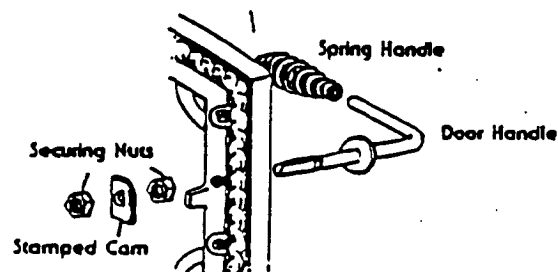

OPERATION

When your installation has been completed and inspected, you are ready to build your first fire.

To learn the proper operation and maintenance of your newly purchased and installed LOPI woodstove, please completely read this handbook. You may wish to highlight portions for easy referral in areas that you are unfamiliar with. It is recommended that you keep this manual as a handy reference guide for questions that may arise in the future, as varying conditions can greatly alter the way your woodstove burns.

The more familiar you become with your new LOPI stove the more enjoyment you will experience from being able to operate it at its peak level.

THERMOMETER

Purchasing a stove thermometer is highly recommended for monitoring the stove temperature. On an insert, the thermometer should be located on the center of the top panels, about 1" from panels.

STOVE TOP TEMPERATURES

Approximate burning temperatures for a LOW BURN MODE (Overnight burn) is 200-400 degrees Fahrenheit. MEDIUM BURN MODE is 400-600 degrees Fahrenheit and HIGH BURN MODE is 600-800 degrees Fahrenheit. It is recommended that the stove be burned very hot (850 degrees F.) for approximately 30 minutes in order to burn the creosote out of the firebox, flue and off the glass after an overnight or low burn. The burn mode recommended for normal operation, achieving a high efficiency level, is medium high (approximately 600 - 675 degrees).

It will probably take a couple of weeks to become familiar with what settings achieve the desired burning temperatures. There is no set position on the draft control as each persons installation and wood type varies.

SEASONING THE PAINT

Burn the stove at a low to medium burn for the first few days to allow the seasoning of the paint to take place. High temperatures will damage the paint.

For the first few days the stove, and pipe if freestanding, will give off an odor and a small amount of smoke. This is to be expected as the high temperature paint becomes seasoned to the metal. During the first few days allow adequate ventilation for smoke and odor.

NOTE: TO PREVENT THE DOOR GASKETING FROM STICKING TO THE SEASONING PAINT OPEN THE LOADING DOOR "SLOWLY" AND OFTEN DURING THE FIRST WEEK OF OPERATION.

LOPI MODEL X - CONTROLS

The LOPI Model X is equipped with front controls. The combustion air control (draft) is located under the ashlip, the by-pass control (damper) on top of the stove (see illustration), both are operated with a simple push/pull movement.

When both controls are completely pulled out the stove is in the "start up" position. The combustion air control allowing maximum air entry and the by-pass control allowing fuel gases to by-pass the flame impingement chamber. (Refer page 16 for first fire operation).

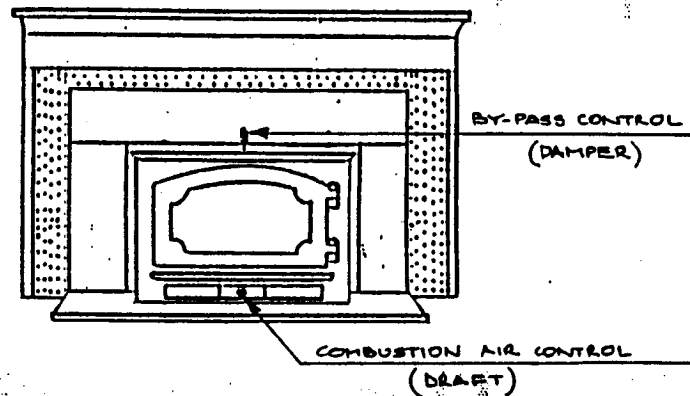

NOTICE

IT IS VERY IMPORTANT TO REMEMBER TO OPEN THE BYPASS BEFORE OPENING THE LOADING DOOR!

THIS WILL PREVENT THE POSSIBILITY OF SMOKE SPILLAGE INTO YOUR HOME DURING STOVE OPERATION!

FIRST FIRE:

1. To operate this unit, set the DRAFT and BY-PASS controls to their open positions. Open the loading door and build a small fire directly on the firebrick floor by using paper and dry kindling. Close and secure the doors on the insert and wait for a draft to establish the fire. Continue to add kindling and small pieces of wood until a firm layer of hot coals has been established on the firebox floor. (NOTE: IT MAY BE REQUIRED TO CRACK DOOR OPEN ABOUT 1/4" TO ESTABLISH AN UP-DRAFT IN YOUR CHIMNEY).

NOTE: When reloading the insert always form a 4" to 6" wide trench in front of the wood load to allow the lower primary air to enter the fire box unrestricted.

During the first few fires it may be a little harder to start the fire as the firebricks will contain some moisture. As the bricks dry and a good bed of ash is established. The fire will be easier to start up.

2. Once you have established a hot bed of coals, place two or three thoroughly dried (seasoned) logs on the coals and close the doors. REMEMBER: WHEN ADDING WOOD TO THE FIRE, FIRST OPEN DAMPER BEFORE OPENING THE LOADING DOORS. THIS WILL PREVENT THE POSSIBILITY OF SMOKE SPILLAGE INTO YOUR HOME.

3. After about 35 to 40 minutes the wood should be burning intensely. After about one hour the insert should reach optimum burning conditions. (This may take a little longer at higher elevations). At this point the insert can be dampered down by adjusting the draft controls toward the closed position and by completely closing the damper control. Take time to experiment with the draft controls to see how it alters the burn rate of the fire. By adjusting the draft control, you will be able to fine-tune the fire to your desired burn rate.

4. For the first few fires, keep the combustion rate at a MEDIUM-BURN rate (400-600 degrees). Avoid burning the fires with the draft and damper controls in the wide open position for long periods of time. This will result in very short, hot burning fires with most of the heat escaping up the chimney.

WARNINGS FOR ALL STOVES:

NEVER BUILD A ROARING FIRE IN A COLD STOVE. ALWAYS WARM YOUR STOVE UP SLOWLY AND TO A MODERATE LEVEL.

NEVER OPEN LOADING DOORS OF A BURNING STOVE WHEN THE COMBUSTION AIR INLETS HAVE BEEN CLOSED. DOING SO COULD RESULT IN A SUDDEN FLASH OF FLAME AS THE FIRE REIGNITES. ALWAYS OPEN DRAFT AND DAMPER CONTROLS BEFORE OPENING LOADING DOORS.

ALWAYS OPEN THE DOOR ABOUT HALF AN INCH OR SO AND WAIT A MINUTE. THIS WILL ALLOW THE PRESSURE INSIDE THE CONTROLLED COMBUSTION FIREBOX TO EQUALIZE WITH THE ROOM PRESSURE AND REDUCE THE POSSIBILITY OF SMOKE POURING INTO THE ROOM.

MANY NEWER HOMES ARE BUILT AIR TIGHT TO CONSERVE ENERGY. IN THESE CASES, FRESH AIR FROM THE OUTSIDE MUST BE PROVIDED IN THE FORM OF A COMBUSTION AIR INLET. VENTILATION IS NEEDED NOT JUST FOR PROPER COMBUSTION, BUT FOR THE OCCUPANTS OF A HOME. IN MOST HOMES THERE IS AN AIR LEAKAGE SUFFICIENT TO SUPPORT STOVE COMBUSTION. IN WELL-INSULATED "TIGHT" HOMES, PROPER DRAFT FOR STOVE BURNING CANNOT BE ACHIEVED WITHOUT VENTILATION. IT IS ADVISABLE UNDER ALL CONDITIONS TO LEAVE THE COMBUSTION AIR INLET OPEN OR A WINDOW SLIGHTLY OPEN TO ALLOW A CONSTANT SOURCE OF AIR WHEN YOUR STOVE IS IN OPERATION.

IT IS NORMAL FOR A STOVE TO MAKE POPPING AND CRACKING NOISES AS IT EXPANDS DURING THE "HEATING UP" PROCESS. THESE NOISES SHOULD BE MINIMAL ONCE OPERATING TEMPERATURES ARE REACHED.

ARTIFICIAL FIRE LOGS AND MANUFACTURED COAL BRICKS ARE NOT RECOMMENDED FOR USE IN YOUR LOPI. MOST MANUFACTURERS USE COAL OIL, PARAFFIN, OR OTHER FLAMMABLE LIQUIDS IN THE MANUFACTURING OF LOGS AND BRICKS THAT MAY CAUSE AN UNCONTROLLABLE FIRE.

Now that you are aware of how your controls are operated and the proper technique for the start-up and first fire of your stove you are ready to learn more about the fuel used - wood.

WOOD

Choosing the kind of firewood to burn in your stove depends on what is available to you. If all you can obtain is softwoods, obviously, that will be your choice.

Softwoods such as pine and fir are easily ignited and burn rapidly with hot flames. But, since they burn so easily and quickly you will have to spend more time loading your firebox, especially in the high burn mode. With soft woods it will be much more difficult to achieve an overnight burn.

If you do have a choice, it is best to use the more dense hardwoods for a longer lasting fire. Also, it is a good idea once the fire is established, to use larger diameter logs stacked tightly together. This will promote a longer burn time.

The ultimate arrangement would be to have a mix of softwoods and hardwoods. This way you could use the softwood for ease in startup and the hardwood for longer burn times.

So that you have an idea of how firewood is sold, you should first know that the most common measurement is the standard "cord". A cord is a nicely stacked pile of logs measuring 4 feet by 4 feet by 8 feet. ALWAYS look for the driest wood especially if you must purchase wood by weight. Unseasoned, wet wood is much heavier.

AVERAGE HOURS PER CORD

SPECIES	WEIGHT	BTU'S	HR/PER CORD
	PER CORD		AT 40K BTU'S PER HOUR
ALDER	2540	19,050,000	476.
APPLE	4400	33,000,000	825.
ASH	3440	25,800,000	645.
BIRCH, WHITE	3040	22,800,000	705.
CEDAR	2060	15,450,000	386.
COTTONWOOD	2160	16,200,000	405.
DOGWOOD	4230	31,725,000	793.
ELM	2260	16,950,000	423.
FIR, DOUG	2970	22,275,000	556.
HEMLOCK	2700	20,250,000	506.
MAPLE, RED	3200	24,000,000	600.
OAK, RED	3680	27,600,000	690.
OAK, WHITE	4200	31,500,000	787.

AVERAGE HOURS PER CORD CONTINUED:

PINE, WHITE	2250	16,875,000	421.
REDWOOD	2400	18,000,000	450.
SPRUCE, NORWAY	2240	16,800,000	420.

***AT 20% MOISTURE CONTENT.**

USE DRY, SEASONED WOOD

Moisture content of the wood affects the way any stove operates. Well seasoned wood (split, stacked and kept dry for at least 12 months) is your best fuel choice.

Wet wood not only causes more work for you due to the increase in weight making it more burdensome to carry, but most importantly it will not burn as efficiently. You will receive less heat output from a wet piece of wood because it takes energy to evaporate the water, energy that should be used for heating your home. When a wet piece of wood is placed in your stove it will also cause more creosote deposit on the glass and in the stove, flue and chimney. The primary reason for this is as the water evaporates from the wood it will "spit" creosote-like material. If you can hear your wood sizzle or you can see moisture bubbling from the ends of the logs placed in a hot stove, your wood is too wet!!

Another big advantage to burning seasoned wood, aside from higher efficiency and less creosote, is **LESS POLLUTION!!!!**

Your wood should be stored in a well sheltered, ventilated area to allow proper drying during the year to come. This is necessary even if you've purchased seasoned wood.

NOTE: Be careful not to dislodge the firebrick baffle when loading your firebox.

CREOSOTE

Creosote is a tarry liquid or solid resulting from the distilling of wood during the combustion process. Using wet wood or burning at lower temperatures will result in a heavier creosote deposit forming. Creosote vapors will condense in a relatively cool chimney flue of a slow burning fire. As a result, creosote residue accumulates on the interior surface of the chimney and flue pipes, considerably reducing their diameter. When ignited, this creosote makes an extremely hot and dangerous fire. The chimney should be inspected at least once every 2 months during the heating season to determine if a creosote build-up of approximately 1/4" has accumulated. If this is the case, the creosote should be removed to reduce the risk of a chimney fire.

Most problems with creosote are due to poor chimneys with low draft and cold walls, and to a low rate of burning when little heat is needed during the spring and fall months. Burning green and resinous wood also creates creosote.

WAYS TO PREVENT AND KEEP UNIT FREE OF CREOSOTE

1. Burn your stove with draft and damper controls wide open for about 35-45 minutes daily during the burning season (850 degrees F.). This will burn out creosote deposits within the heating system.
2. Burn the stove with draft and damper controls wide open for about 20 minutes every time you apply fresh wood. This allows wood to achieve the charcoal stage faster and burns wood vapors which might otherwise be deposited within the system.
3. **BURN ONLY SEASONED WOOD:** Avoid burning wet or green wood. Seasoned wood has been dried at least one year.
4. A small more intense fire is preferable to a large smoldering one that will deposit creosote within the system.
5. Never completely close the damper control while the unit is in operation. Closing the control while burning will allow unburned gas vapors to escape and be deposited within the chimney.
6. Establish a routine for using your new stove. Check daily for creosote build-up until experience shows how often you need to clean it to be safe. Be aware that the hotter the fire, the less creosote is deposited on the glass and chimney system. Weekly inspection and cleaning may be necessary during times of heavy stove use. Contact your local fire authority for information on how to handle a chimney fire. Have a clearly understood plan to handle such a fire.
7. Have your chimney system and unit cleaned by a competent chimney sweep twice a year during your first burning season, and at least once a year thereafter.

WARNING: THINGS TO REMEMBER IN CASE OF A CHIMNEY FIRE:

1. CLOSE ALL DRAFT AND DAMPER CONTROLS.
2. DO NOT OPEN LOADING DOORS.
3. CALL THE FIRE DEPARTMENT.

BURNING YOUR STOVE EFFICIENTLY

Your LOPI woodstove is designed to heat your home as efficiently as possible with the lowest amount of creosote build-up and pollutants being emitted. There are a few things you can do to aid in this.....

On cold days, when you wish for high heat output from your stove, load the stove fully after the fire has been established and burn at a medium - high to high burn mode. When a comfortable heat level in your home has been reached, subsequent loadings should be of lesser amounts of wood. On warmer days, burn smaller fires (using less wood). This method will give you the most efficient burn possible from your LOPI.

Although the fire will burn longer at a lower setting, your stove will not produce as much heat and it will leave the stove, chimney, and glass sooted and will emit a larger amount of pollutants into the environment.

For an overnight burn establish a well burning fire. Before you are ready to retire, completely fill the stove with wood. With the controls in the fully open position let the fire burn intensely for 20-30 minutes. Next, close the damper and adjust the draft control so that a low, lazy flame is visible. In the overnight burn you should be able to maintain a fire about 6-9 hours (depending on wood type used) and have a coal bed, no visible flame, left to start the morning fire. After an overnight burn, to re-establish a fire, open the controls fully and stir the ashes to bring the hot coals to the surface. Then, follow instructions under "first fire". If you dampen the fire down too low you will not only lower the heat output but you'll be promoting creosote build-up. Again, it will take a few days practice to achieve the desired setting.

CHIMNEY SIZE AND PROPER DRAFT

The performance of your unit depends a great deal on the type and size of your chimney and connector as well as its location. Your dealer should have covered the importance of this when you purchased your unit.

If you own an insert you will want to make sure that your existing fireplace is in sound condition and has a proper and correctly sized flue. The answer insert has a 6" flue opening. The x inserts have a 6" flue opening. If the flue opening of your fireplace is too large you will not be able to reach optimum burning temperatures with your insert and you may experience smoke feed-back. This is because the large flue opening will not heat up enough to provide sufficient draft for your unit.

If you experience problems check for the following and correct:

1. Leaky chimney-air leaking around a loose fitting cleanout door, flue pipe joints not tight or defective masonry.
2. Improper chimney height-your chimney must extend above the roof to the proper height in order to promote sufficient draft. If it does not, you will experience a slow burn and smoke feedback. The chimney should extend at least 3 feet above flat roofs. On pitched roofs, chimneys should be at least two feet higher than any point on the roof within 10 feet. A high chimney produces better draft and reduces chances of downdrafts caused by wind being deflected from the roof.
3. Chimney size-If your masonry chimney is too large or small it will not adequately vent your stove. Minimum height should be 13 feet with a minimum inside cross-sectional area of 64 square inches. The diameter should be sized appropriately for your model of stove.
4. Obstructions-your chimney should be examined regularly for creosote build-up or other obstructions. If you have a chimney cap be certain to check this also.
5. Elbow Restrictions- If your flue pipe connector has too many elbows this will reduce the draft. Whenever possible there should be NO elbows. The connector should be as short and straight as possible and enter the chimney higher than the outlet on the stove. Avoid long horizontal runs. Instead use adjustable elbows, if needed, to create an upward slope to the pipe.
6. Cold air- block - if your chimney and/or connector pipe is located outside of your home it will not heat up as well, especially under cold weather conditions, promoting a slower draft.
7. Trees or other Topographical Barriers close to the chimney - these will hinder the operation possibly causing a down draft or slow insufficient draft to take place.

MOST IMPORTANTLY KEEP YOUR CHIMNEY FREE OF CREOSOTE. IT WILL REDUCE THE POSSIBILITY OF A CHIMNEY FIRE!!!

DO NOT use the chimney if it is unlined. Also, DO NOT connect the insert to a chimney system serving another appliance.

ASH DISPOSAL

LOPI stoves feature a convenient ashlip for easy removal of ash. During constant use, ashes should be removed every few days. **DO NOT ALLOW ASHES TO BUILD UP TO THE LOADING DOORS!!!!**

Only remove ashes when the fire has died down. Even then, expect to find a few hot embers.

Ashes should be placed in a metal container with a tight fitting lid. The closed container of ashes should be placed on a non-combustible floor or on the ground, well away from all combustible materials, pending final disposal. If the ashes are disposed of by burial in soil or otherwise locally dispensed, they should be retained in the closed container until all cinders have thoroughly cooled. Other waste should not be placed in the ash container.

* Please take care to prevent the build-up of ash around the start-up air housing located inside the stovebox, under the loading door lip.

OPTIONAL FAN OPERATION:

All fans have a built in thermostat. All fans are operated by selecting either the automatic (thermostatically controlled) or manual mode and the desired blower speed.

NOTE: ALWAYS TURN THE BLOWER OFF WHEN THE STOVE IS NOT IN OPERATION.

When the fan is on the AUTO position, it will automatically turn on at approximately 125 degrees fahrenheit (activated by thermostat) and shut off when the stove cools to approximately 85 degrees F. Using the speed control switch you may vary the speed or shut off the fan at any time.

GENERAL MAINTENANCE

FAN MAINTENANCE

You should remove your fan from the unit at least twice a year for cleaning. Dust will accumulate on the fan cover as well as the fan motor and impellers. These parts should be cleaned to insure adequate flow of air and minimize strain on the motor. At this time the motor should be lubricated using a light gauge machine oil (i.e. sewing machine oil).

STOVE MAINTENANCE

It is highly recommended that you periodically lubricate any moving parts such as the door hinges, draft, damper and start-up control rods. This will eliminate any scraping or squeaking noises as well as allow the parts to move more freely. A high temperature lubricant (i.e. Permatex Industrial (R) anti-seize lubricant) is required for this. Graphite or low temperature lubricants will only last for a few days.

At the end of each heating season, remove all ashes from your stove. With a wire brush remove any scale on the inside of the firebox. Replace any broken firebrick, worn glass, and door gasketing material. The exterior of the stove can be touched up using high temperature "Forrest" paint, available at your LOPI dealer. To touch up paint, first sand the area to be painted with 120 grit sandpaper, clean with water only and dry with a clean cloth. Paint using a "light" covering coat. The area painted may appear darker until the paint has gone through the curing process described on page 2.

BRASS MAINTENANCE

If your unit is purchased with solid brass door(s), and brass ashlip trim, be sure to use only brass cleaner approved by LOPI, purchased at your LOPI dealer. DO NOT UNDER ANY CIRCUMSTANCES CLEAN BRASS WITH AN ABRASIVE CLEANER.

GLASS MAINTENANCE

Should soot or creosote appear on the glass during operation, clean when the stove is cold with a non-abrasive glass cleaner available through your stove dealer. Creosote deposits on the glass indicate the wood being burned is not properly seasoned or that the stove is being burned at low temperatures. Remember to fire at a medium-high burn mode, because dampering the unit down too low will result in a low burning, smoldering fire that can deposit creosote throughout the system.

If the glass should break, wait until the stove and glass is cool before removing. Do not leave the fire unattended during this cool down period in case sparks should escape through the broken glass.

To replace the glass, simply remove the door and unscrew the glass retainer. Replace the broken glass with only LOPI's Glass Kit , available at all authorized LOPI Dealers. The replacement glass is high temperature, high shock glass of Corning Pyroceram(R) or Technical Neoceram(R) (5mm thick). Under normal operating conditions the glass will not break.

JUNE 1988

TO LOPI OWNERS:

TRAVIS INDUSTRIES, INC. warrants LOPI woodstoves, hearth heaters and fireplace inserts to be defect-free in material and workmanship for five (5) years from the date of purchase, with the exception of the unit's fan, which is warranted for one (1) year from the date of purchase to be defect free in material and workmanship.

Exclusions to this limited warranty include: Injury malfunction of the product, loss, damage, defect, failure to function due to accident, negligence, misuse, improper installation, lack of proper and regular maintenance, damage incurred while the unit is in transit, alteration, or act of God. In addition, this warranty excludes paint discoloration, chipping paint, firebricks, glass and gasketing. Catalytic units are covered by a separate warranty by the manufacturer of that part.

This limited warranty excludes damage caused by normal wear and tear, such as paint discoloration or chipping, worn or torn gasketing, eroded or cracked firebricks, etc. Also excluded is damage to the unit caused by abuse, improper installation or use not set forth in the LOPI Owner's Manual. Creating an overfired condition in the unit voids this warranty. An overfired condition is defined as a condition in which the unit is allowed to glow red. Warped metal parts and discolored or burned-off paint result from an over fired condition.

Also excluded is deformation of metal parts due to heat. Because of the range of temperature extremes during normal operation, expansion and contraction of metal parts and noises associated with expansion and contraction of metal parts is considered normal and is not covered by this warranty. Permanent deformation of metal parts of one and a half times the metal thickness or less when measured at room temperature is permissible and is not covered by this warranty.

TRAVIS INDUSTRIES, INC. is free of liability for any damages caused by the unit, as well as inconvenience expenses, material and labor charges incurred by the removal or reinstallation of any LOPI unit. Incidental or consequential damages are not covered by this warranty. In some states, the exclusion of incidental or consequential damage may not apply.

It is the responsibility of the purchaser to obey all Federal, State and Local regulations that apply to the installation and operation of wood burning appliances. LOPI is not responsible for any fines or costs incurred in order to meet such regulations or for any upgrading or retro-fitting required to meet any Federal, State or Local regulations for safety or air quality.

Only the original purchaser of a LOPI appliance is covered by this warranty. If the unit is used for commercial purposes, it is excluded from this warranty.

This warranty does not cover any loss or damage incurred by the use or removal of any component or apparatus to or from the LOPI unit without the express written permission of TRAVIS INDUSTRIES, INC. This includes the use of any fan not approved by TRAVIS INDUSTRIES, INC. and not bearing a TRAVIS INDUSTRIES, INC. label of approval.

No dealer, distributor, or similar person has the authority to represent or warrant LOPI products beyond the terms contained within this warranty. TRAVIS INDUSTRIES, INC. assumes no liability for such warranties or representations..pa

Any statement or representation of LOPI products and their performance contained in LOPI advertising, packaging literature, or printed material is not part of this limited warranty.

This warranty is automatically voided if the unit's serial number has been removed or altered in any way.

This warranty is limited to the time frame set forth above. In some states, time limitations on warranties do not apply.

TRAVIS INDUSTRIES, INC. LIMITED FIVE YEAR WARRANTY

THIS LIMITED WARRANTY IS THE ONLY WARRANTY SUPPLIED BY TRAVIS, THE MANUFACTURER OF THE UNITS. ALL OTHER WARRANTIES, WHETHER EXPRESS OR IMPLIED, ARE HEREBY EXPRESSLY DISCLAIMED AND PURCHASER'S RECOURSE IS EXPRESSLY LIMITED TO THE WARRANTIES SET FORTH HEREIN.

HOW TO USE YOUR LOPI FIVE YEAR WARRANTY: If you find your unit to be defective in workmanship or material within a 5 year period from the date purchased contact your local authorized LOPI dealer. If your dealer is unable to repair your units defect, he may process a warranty claim through TRAVIS INDUSTRIES, INC., including the name of the dealership where you purchased the unit, your receipt showing the date of the units purchased, and the serial number on your unit. At that time, you will be asked to ship your unit, freight charges prepaid, to TRAVIS INDUSTRIES, INC. TRAVIS, at its option, will repair or replace, free of charge, your LOPI unit if it is found to be defective in material or workmanship within the time frame stated within this limited warranty. In addition, TRAVIS will refurbish your unit at no charge to you, restoring its appearance and condition. TRAVIS INDUSTRIES, INC. will ship your unit, freight charges prepaid by TRAVIS, to your regional distributor, or your dealership, which ever you find more convenient.

To register your TRAVIS INDUSTRIES, INC. Five Year Warranty, complete the enclosed warranty card and mail it within ten (10) days of the unit purchase date to: TRAVIS INDUSTRIES, INC., 10850 117th PL N.E., Kirkland, WA 98033.

OTHER RIGHTS: This warranty provides you with certain legal rights. You may have additional rights, which vary from state to state, in regards to this warranty.

UNIT SERIAL NUMBER _____

DATE OF PURCHASE _____

DEALER NAME & ADDRESS WHERE UNIT WAS PURCHASED _____

(Complete the above information, and save this page, with purchase receipt, for your records).

TRAVIS INDUSTRIES, INC.
10850 117TH PL N.E.,
KIRKLAND, WA 98033