

# Berkshire GS2

(with screen)

## Owner's Manual



**⚠ WARNING: FIRE OR EXPLOSION HAZARD**

Failure to follow safety warnings exactly could result in serious injury, death, or property damage.

- Do not store or use gasoline or other flammable vapors and liquids in the vicinity of this or any other appliance.
- **WHAT TO DO IF YOU SMELL GAS**
  - Do not try to light any appliance.
  - Do not touch any electrical switch; do not use any phone in your building.
  - Leave the building immediately
  - Immediately call your gas supplier from a neighbor's phone. Follow the gas supplier's instructions.
  - If you cannot reach your gas supplier, call the fire department.
- Installation and service must be performed by a qualified installer, service agency or the gas supplier.



**HOT GLASS WILL CAUSE BURNS**

**DO NOT TOUCH GLASS UNTIL COOLED**

**NEVER ALLOW CHILDREN TO TOUCH GLASS**

**A barrier designed to reduce the risk of burns from the hot viewing glass is provided with this appliance and shall be installed for the protection of children and other at-risk individuals.**

Tested and Listed by



**Intertek**

ANSI Z21.88-2014  
CSA 2.33-2014

- Built-In Direct Vent Stove
- Natural Gas or Propane
- Residential or Mobile Home

**This appliance may be installed in an aftermarket, permanently located, manufactured home (USA only) or mobile home, where not prohibited by local codes.**

**This appliance is only for use with the type of gas indicated on the rating plate. A conversion kit is supplied with the appliance.**

**INSTALLER: Leave this manual with the appliance.**

**CONSUMER: Retain this manual for future reference.**

## Introduction

We welcome you as a new owner of a Lopi Berkshire GS2 stove. In purchasing a Berkshire you have joined the growing ranks of concerned individuals whose selection of an energy system reflects both a concern for the environment and aesthetics. The Berkshire is one of the finest home heaters the world over. This manual will explain the installation, operation, and maintenance of this stove. Please familiarize yourself with the Owner's Manual before operating your heater and save the manual for future reference. Included are helpful hints and suggestions that will make the operation and maintenance of your new stove an easier and more enjoyable experience. We offer our continual support and guidance to help you achieve the maximum benefit and enjoyment from your heater.

## Important Information

No other Berkshire Stove has the same serial number as yours. The serial number is on the listing plate chained to the gas control valve.

This serial number will be needed in case you require service of any type.

Model:           Lopi Berkshire GS2 Stove          

Serial Number: \_\_\_\_\_

Purchase Date: \_\_\_\_\_

Purchased From: \_\_\_\_\_

\_\_\_\_\_

\_\_\_\_\_

### Mail your Warranty Card Today, and Save Your Bill of Sale.

To receive full warranty coverage, you will need to show evidence of the date you purchased your heater. Do not mail your Bill of Sale to us.

We suggest that you attach your Bill of Sale to this page so that you will have all the information you need in one place should the need for service or information occur.

## Listing Details

This appliance was listed to ANSI Z21.88. The listing label is attached to the appliance near the gas control valve. A copy is shown on page 40.

### Massachusetts Approval

This manual has been submitted to the Massachusetts Board of State Examiners of Plumbers and Gas Fitters.

### National Fireplace Institute



<b>Introduction</b> .....	<b>2</b>	<b>Log Installation</b> .....	<b>27</b>
<b>Important Information</b> .....	<b>2</b>	Rear Log Placement .....	27
<b>Listing Details</b> .....	<b>2</b>	Left Front Log Placement .....	28
Features: .....	6	Right Twig Placement .....	28
Installation Options: .....	6	Right Front Log Placement .....	29
<b>Heating Specifications</b> .....	<b>6</b>	Left Cross Log Placement .....	29
<b>Dimensions &amp; Weight</b> .....	<b>6</b>	Right Cross Log Placement .....	30
<b>Electrical Specifications (for optional blower)</b>	<b>6</b>	Left Twig Placement .....	30
<b>Fuel</b> .....	<b>6</b>	Center Twig Placement .....	31
<b>Packing List</b> .....	<b>7</b>	Ember Placement .....	32
<b>Additional Items Required</b> .....	<b>7</b>	Rockwool Installation .....	32
<b>Installation Overview</b> .....	<b>7</b>	<b>Before You Begin</b> .....	<b>33</b>
<b>Stove Clearances</b> .....	<b>8</b>	<b>Location of Controls - See explanation below</b>	<b>33</b>
<b>Mobile Home Requirements</b> .....	<b>8</b>	<b>Starting the Stove for the First Time</b> .....	<b>34</b>
<b>Heater Placement Requirements</b> .....	<b>9</b>	<b>Turning the Stove On and Off</b> .....	<b>34</b>
<b>Floor Protection Requirements</b> .....	<b>9</b>	<b>Comfort Control</b> .....	<b>34</b>
<b>Electrical Requirements</b> .....	<b>9</b>	<b>Adjusting the Flame Height</b> .....	<b>34</b>
<b>Optional Wall Switch or Thermostat</b>		<b>Accent Light</b> .....	<b>35</b>
<b>Installation</b> .....	<b>10</b>	<b>Adjusting the Optional Blower Speed</b> .....	<b>35</b>
Parallel Connection   Series Connection .....	10	<b>Continuous Pilot / GreenSmart™ Pilot Switch</b>	<b>35</b>
<b>Gas Line Installation</b> .....	<b>11</b>	<b>Normal Operating Sounds</b> .....	<b>36</b>
Gas Inlet Pressure .....	11	<b>Normal Operating Odors</b> .....	<b>36</b>
<b>Vent Requirements</b> .....	<b>12</b>	<b>Maintaining Your Stove's Appearance</b> .....	<b>37</b>
Altitude Considerations .....	12	Painted Surfaces .....	37
Approved Vent .....	12	Enamel Surfaces .....	37
Vent Installation .....	12	Patina Surfaces .....	37
<b>Approved Vent Configurations</b> .....	<b>13</b>	Front Glass .....	37
Restrictor Position .....	13	<b>Battery Replacement</b> .....	<b>37</b>
Measuring Vent Lengths .....	13	Power Backup Batteries .....	37
<b>Vertical Terminations with Zero, Two, or Four</b>		Control Panel Light Battery .....	37
<b>45° Elbows</b> .....	<b>14</b>	<b>Accent Light Replacement</b> .....	<b>38</b>
<b>Horizontal Termination with One 90° Elbow</b>	<b>15</b>	<b>Yearly Service Procedure</b> .....	<b>38</b>
<b>Horizontal Termination with Two Elbows</b>		<b>Troubleshooting Table</b> .....	<b>39</b>
<b>(one 90° vertical and one 90° or 45°</b>		<b>Replacement Parts List</b> .....	<b>39</b>
<b>horizontal elbow)</b> .....	<b>16</b>	Safety Label .....	40
<b>Horizontal Termination with Three 90°</b>		<b>CONDITIONS &amp; EXCLUSIONS</b> .....	<b>41</b>
<b>Elbows (all vertical)</b> .....	<b>17</b>	<b>IF WARRANTY SERVICE IS NEEDED:</b> .....	<b>41</b>
<b>Vertical Terminations with Two 90° Elbows</b>	<b>18</b>	<b>LP Conversion Instructions</b> .....	<b>42</b>
<b>Vertical Terminations with Three 90° Elbows</b>		<b>GS2 Remote Installation</b> .....	<b>46</b>
<b>(Two 90° Vertical and One 45° or 90°</b>		Packing List .....	46
<b>Horizontal Elbow)</b> .....	<b>19</b>	Warnings .....	46
<b>Vent Termination Requirements (see</b>		Remote Control / Pilot Warnings .....	46
<b>illustration below)</b> .....	<b>20</b>	Base Wiring Diagram .....	47
<b>Class A Chimney Conversion Kit</b> .....	<b>21</b>	GS2 Remote Wiring Diagram .....	48
<b>Interior Masonry Chimney Conversions</b> .....	<b>22</b>	Installation .....	49
<b>Steps for Finalizing the Installation</b> .....	<b>23</b>	Order of Installation .....	54
Air Shutter Adjustment .....	24	Wiring the Blower to the GSR2 IFC (Bypassing the	
<b>Face and Glass Removal</b> .....	<b>25</b>	Rheostat) .....	54
		<b>Index</b> .....	<b>60</b>

- Failure to follow all of the requirements may result in property damage, bodily injury, or even death.

**Young children should be carefully supervised when they are in the same room as the appliance. Toddlers, young children and others may be susceptible to accidental contact burns. A physical barrier is recommended if there are at risk individuals in the house. To restrict access to a fireplace or stove, install an adjustable safety gate to keep toddlers, young children and other at risk individuals out of the room and away from hot surfaces.**

**Children and adults should be alerted to the hazards of high surface temperature and should stay away to avoid burns or clothing ignition. Do not touch the hot surfaces of the heater. Educate all children of the danger of a high-temperature heater.**

**Due to the high temperature, the heater should be located out of traffic and away from furniture and draperies.**

- This unit must be installed by a qualified installer to prevent the possibility of an explosion.
- This appliance must be installed in accordance with all local codes, if any; if not, in U.S.A. follow ANSI Z223.1 and NFPA 54(88), in Canada follow CSA B149.1.
- A manufactured home (USA only) or mobile home OEM installation must conform with the Manufactured Home Construction and Safety Standard, Title 24 CFR, Part 3280, or, when such a standard is not applicable, the Standard for Manufactured Home Installations, ANSI/NCSCS A225.1, or Standard for Gas Equipped Recreational Vehicles and Mobile Housing, CSA Z240.4. This appliance may be installed in Manufactured Housing only after the home is site located.
- All exhaust gases must be vented outside the structure of the living-area. Combustion air is drawn from outside the living-area structure. The venting must not be connected to a chimney flue serving a separate solid-fuel burning appliance.
- Notify your insurance company before hooking up this fireplace.
- The instructions in this manual must be strictly adhered to. Do not use makeshift methods or compromise in the installation. Improper installation will void the warranty and safety listing.
- This heater is approved for use with natural gas (NG) or propane (LP). Burning the incorrect fuel will void the warranty and safety listing and may cause an extreme safety hazard. Direct questions about the type of fuel used to your dealer.
- Contact your local building officials to obtain a permit and information on any installation restrictions or inspection requirements in your area.
- If the flame becomes sooty, dark orange in color, or extremely tall, do not operate the heater. Call your dealer and arrange for proper servicing.
- It is imperative that control compartments, screens, or circulating air passageways of the heater be kept clean and free of obstructions. These areas provide the air necessary for safe operation.
- Do not operate the heater if it is not operating properly in any fashion or if you are uncertain. Call your dealer for a full explanation of your heater and what to expect.
- Do not store or use gasoline or other flammable liquids in the vicinity of this heater.
- Do not operate if any portion of the heater was submerged in water or if any corrosion occurs. Immediately call a qualified service technician to inspect the appliance and to replace any part of the control system and any gas control which has been under water.

## ***Safety Warnings (continued)***

---

- Because this heater can be controlled by a thermostat there is a possibility of the heater turning on and igniting any items placed on or near the appliance.
- Light the heater using the built-in igniter. Do not use matches or any other external device to light your heater.
- Never remove, replace, modify or substitute any part of the heater unless instructions are given in this manual. All other work must be done by a trained technician. Don't modify or replace orifices.
- The viewing glass should be opened only for conducting service.
- Allow the heater to cool before carrying out any maintenance or cleaning.
- Operate the heater according to the instructions included in this manual.
- If the main burners do not start correctly turn the gas off and call your dealer for service.
- This unit is not for use with solid fuel.
- Do not place anything inside the firebox (except the optional artwork).
- **Warning:** Do not operate appliance with the glass front removed, cracked or broken. Replacement of the glass should be done by a licensed or qualified service person.
- Do not throw this manual away. This manual has important operating and maintenance instructions that you will need at a later time. Always follow the instructions in this manual.
- Instruct everyone in the house how to shut gas off to the appliance and at the gas main shutoff valve. The gas main shutoff valve is usually next to the gas meter or propane tank and requires a wrench to shut off.
- A barrier designed to reduce the risk of burns from the hot viewing glass is provided with this appliance and shall be installed for the protection of children and other at-risk individuals.
- If the barrier becomes damaged, the barrier shall be replaced with the manufacturer's barrier for this appliance.
- Clothing or other flammable material should not be placed on or near the appliance.
- Any safety screen, guard, or barrier removed for servicing an appliance must be replaced prior to operating the appliance.
- Installation and repair should be done by a qualified service person. The appliance should be inspected before use and at least annually by a professional service person. More frequent cleaning might be required due to excessive lint from carpeting, bedding material, et cetera. It is imperative that control compartments, burners, and circulating air passageways of the appliance be kept clean.
- **Travis Industries, Inc. grants no warranty, implied or stated, for the installation or maintenance of your heater, and assumes no responsibility of any consequential damage(s).**

**Proposition 65 Warning:** Fuels used in gas, woodburning or oil fired appliances, and the products of combustion of such fuels, contain chemicals known to the State of California to cause cancer, birth defects and other reproductive harm. California Health & Safety Code Sec. 25249.6

## Features:

- Ember Fyre™ Burner for "Wood Fire" Look
- Works During Power Outages (battery backup system)
- High Efficiency
- Optional Thermostat or Remote Control
- Optional Blower for Quicker Heat Distribution
- Convenient Operating Controls
- Variable-Rate Heat Output
- Accent Light

## Installation Options:

- Freestanding Stove
- Horizontal or Vertical Vent
- Residential or Mobile Home
- Straight or Corner Placement
- Bedroom Approved

## Heating Specifications

Approximate Heating Capacity (in square feet)\* ..... 500 - 1,500 with blower, 500 to 1,200 without

Maximum Input ..... 31,000 BTU's

- Heating capacity will vary depending on the home's floor plan, degree of insulation, and the outside temperature.

## Dimensions & Weight

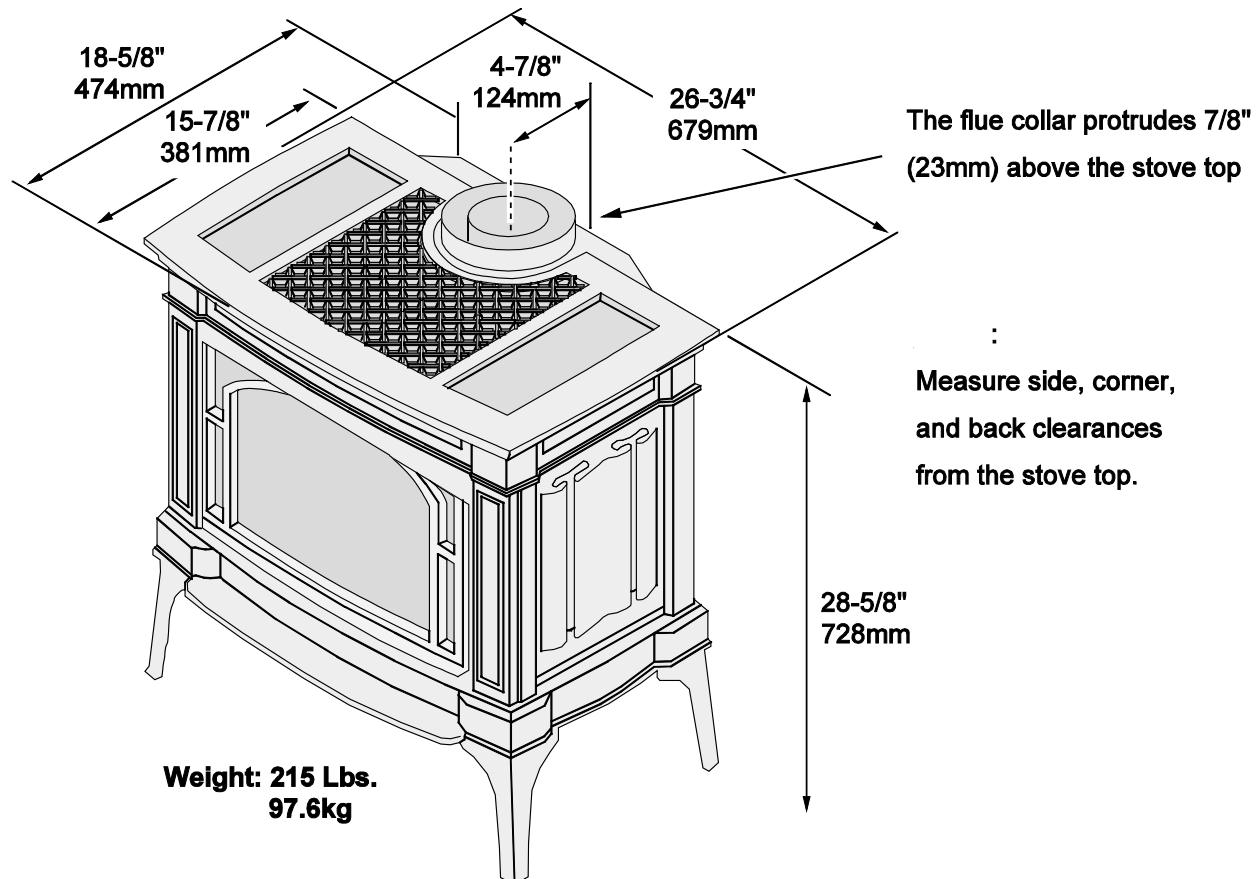

## Electrical Specifications (for optional blower)

Electrical Rating ..... 115 Volts, 1.5 Amps, 60 Hz (180 watt)

## Fuel

This heater is shipped in natural gas (NG) configuration but may be converted to propane (LP) using the included LP conversion kit. The sticker on top of the gas control valve will verify the correct fuel.

## **Installation Warnings**

- ! Failure to follow all of the requirements may result in property damage, bodily injury, or even death.
- ! This heater must be installed by a qualified installer who has gone through a training program for the installation of direct vent gas appliances.
- ! This appliance must be installed in accordance with all local codes, if any; if not, in U.S.A. follow ANSI Z223.1 and NFPA 54(88), in Canada follow B-149.
- ! In Manufactured or Mobile Homes must conform with: In USA, Manufactured Home Construction and Safety Standard, Title 24 CFR, Part 3280; In Canada, CSA Z240.4 and Gas-Equipped Recreational Vehicles and Mobile Housing. This appliance may be installed in Manufactured Housing only after the home is site located.
- ! This stove is designed to operate on natural gas or propane (LP).
- ! All exhaust gases must be vented outside the structure of the living area. Combustion air is drawn from outside the living area structure.
- ! Notify your insurance company before hooking up this stove.
- ! The requirements listed below are divided into sections. All requirements must be met simultaneously. The order of installation is not rigid – the qualified installer should follow the procedure best suited for the installation.

## **Packing List**

- Propane Conversion Kit
- Log Set
- Touch-Up Paint

## **Additional Items Required**

- Vent (see "Venting Requirements" for details)
- Gas Line Equipment (shutoff valve, pipe, etc.)

## **Installation Overview**

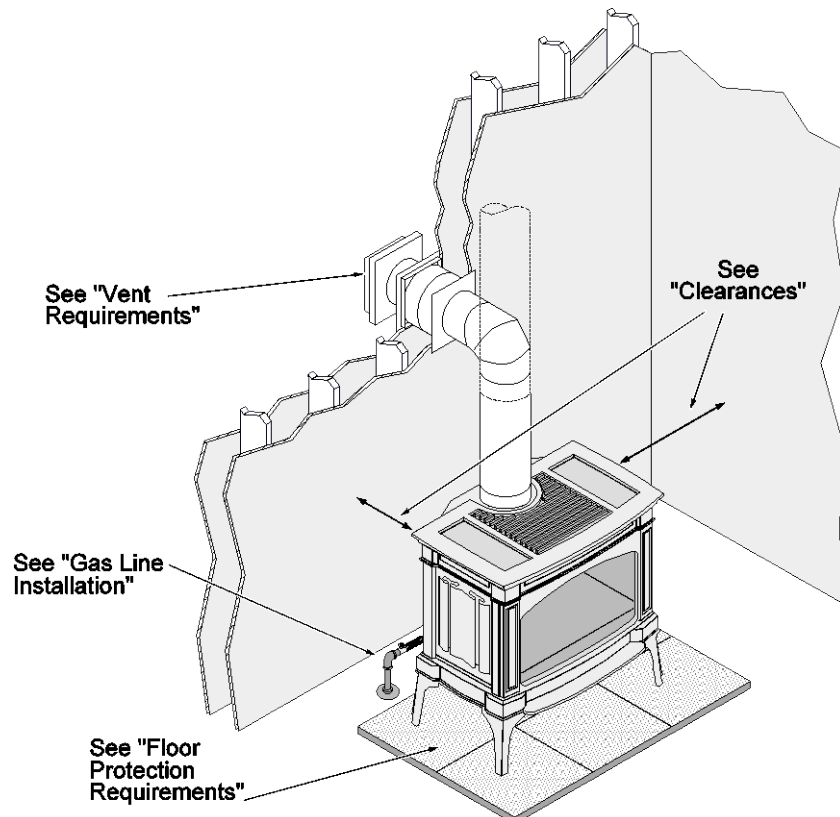



## Installation Hints

- If converting to LP, convert the appliance prior to installation.
- Install the logs last - they are fragile.
- When determining the location of the stove, locate the wall studs (for horizontal penetrations) and ceiling trusses (for vertical penetrations). You may wish to adjust the stove position slightly to ensure the vent does not intersect with a framing member.
- Fumes and smoke from the paint curing and oil burning off the steel may occur the first time you start this heater. This is normal. We recommend you open windows to vent the room.

## Stove Clearances

### Straight Installations

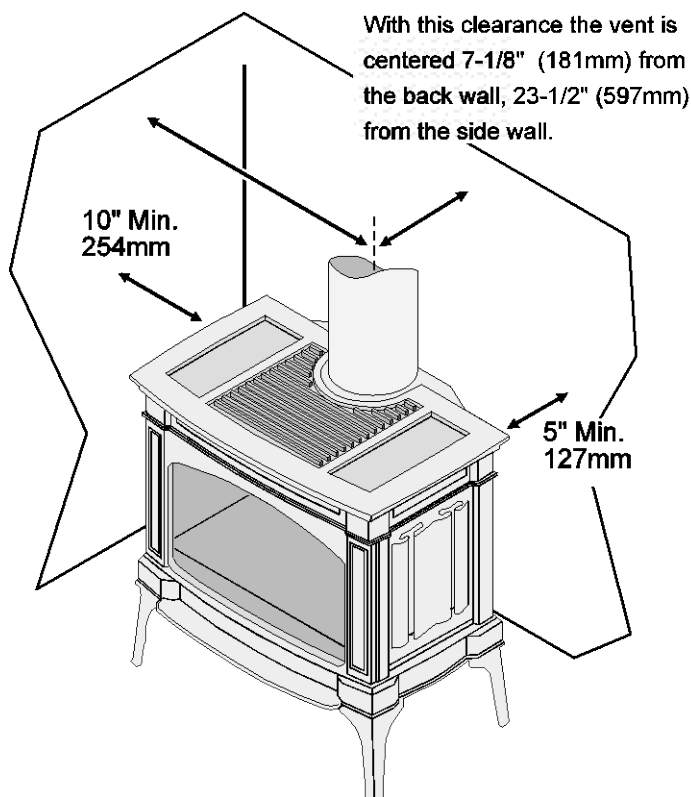

### Corner Installations

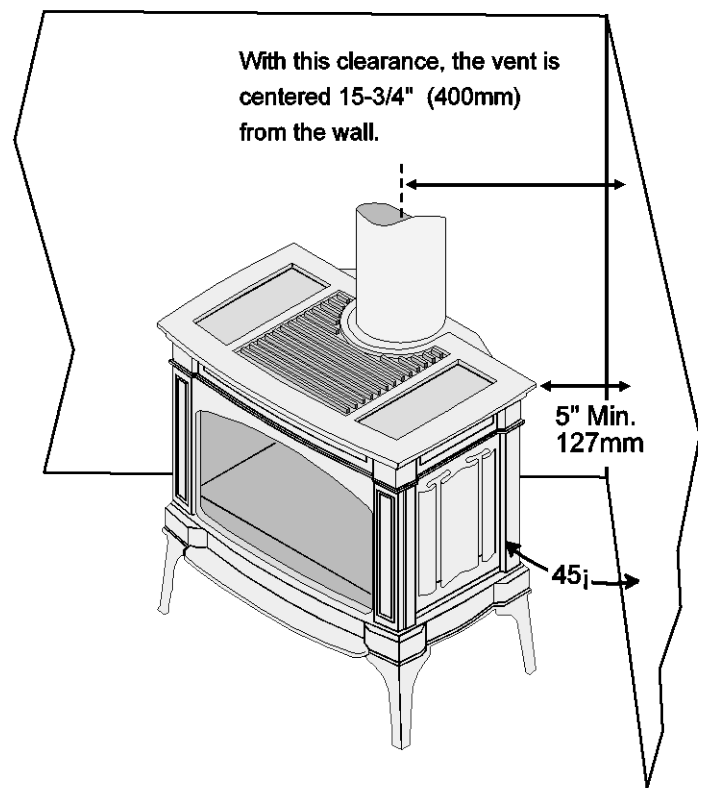

## Mobile Home Requirements

- When the stove is installed in a mobile home, it must be bolted to the floor and the appliance grounded (use the optional blower with a grounded circuit or other suitable grounding method - current ANSI/NFPA 70 or CSA C22.1).



## ***Heater Placement Requirements***

---

- Heater must be installed on a level surface capable of supporting the heater and vent.
- Due to the high temperature, the heater should be located out of traffic and away from furniture and draperies.
- When placed in a location where the floor to ceiling height is under 7 feet (2.134 M), the installation is considered an alcove and must meet the following requirements:
  - The alcove floor to ceiling height must be at least 58" (1474mm) tall
  - The alcove must not be more than 45" (1143) deep before the ceiling returns to 7' (2134mm).
  - The alcove must be at least 46-3/4" (1188mm) wide
- The heater must not be placed so the vents below or above the door, along the sides of heater, or along the back of the heater can become blocked.
- This heater may be placed in a bedroom. Please be aware of the large amount of heat this appliance produces when determining a location.

## ***Floor Protection Requirements***

---

- When the stove is installed directly on carpeting, vinyl or other combustible material other than wood flooring or a high pressure laminate wood floor, the stove must be installed on a metal or wood protection panel extending the full width and depth of the heater (Minimum 26-3/4" (680mm) wide by 19" (483) deep).

**Make sure these rubber tipped bolts on each leg contact the floor (they dampen any noise that may transmit through the hearth). Do not adjust with weight on the legs, the rubber tips may tear.**

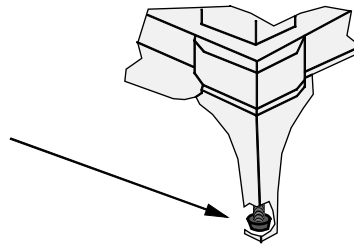

## ***Electrical Requirements***

---

- Plug the stove into a grounded receptacle supplying a minimum 1.5 amps (115 Volts, 60 Hz, 180 watts).

## Optional Wall Switch or Thermostat Installation



Do not connect 110-120 VAC to the gas control valve or wiring system of this stove. The switch must be installed by a qualified installer.

**Caution:** Label all wires prior to disconnection when servicing controls. Wiring errors can cause improper and dangerous operation.

**Note:** When using a GreenSmart™ remote, use the receiver for on/off operation (do not use a wall switch or thermostat).

**Warning:** Make sure all wiring is secure and does not contact hot or moving components.

The wall switch (or thermostat) may bypass the fireplace on/off switch or be installed in parallel or series configuration (see below).

### Parallel Connection

	On / Off Switch <u>ON</u>	On / Off Switch <u>OFF</u>
Thermostat / External Switch <u>ON</u>	Heater is <u>ON</u>	Heater is <u>ON</u>
Thermostat / External Switch <u>OFF</u>	Heater is <u>ON</u>	Heater is <u>OFF</u>

To wire the heater in parallel, follow the directions below:

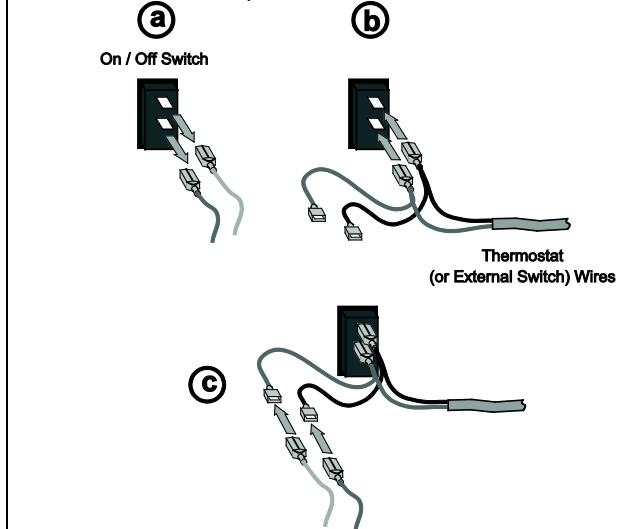

### Series Connection

	On / Off Switch <u>ON</u>	On / Off Switch <u>OFF</u>
Thermostat / External Switch <u>ON</u>	Heater is <u>ON</u>	Heater is <u>OFF</u>
Thermostat / External Switch <u>OFF</u>	Heater is <u>OFF</u>	Heater is <u>OFF</u>

To wire the heater in series, follow the directions below:

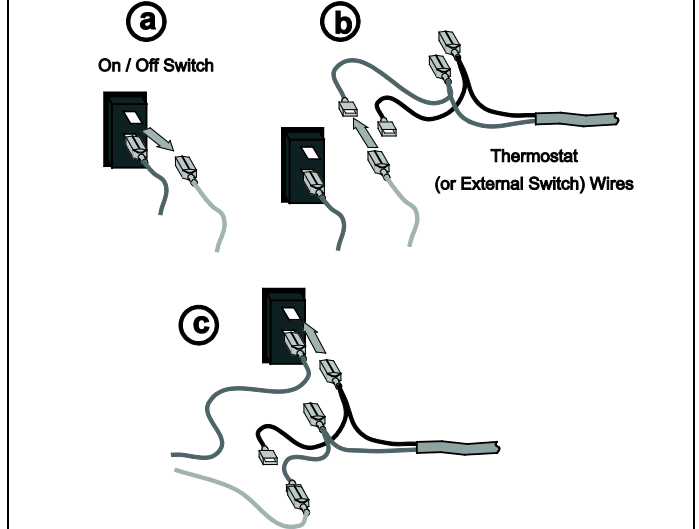

## Gas Line Installation

- ! DO NOT CONNECT THIS UNIT TO A CHIMNEY FLUE SERVING ANOTHER APPLIANCE. The gas line must be installed in accordance with all local codes, if any; if not, follow current ANSI Z223.1 or NFPA 54 in the USA and the current CGA B149 in Canada.
- ! The heater and gas control valve must be disconnected from the gas supply piping during any pressure testing of that system at test pressures in excess of 1/2 psig (3.45 kPa). For pressures under 1/2 psig (3.45 kPa), isolate the gas supply piping by closing the manual shutoff valve.
- This heater is designed for natural gas but can be converted to propane. Check the sticker on top of the gas control valve to verify the correct fuel is used (see page 4).
- Leak test all gas line joints and the gas control valve prior to and after starting the heater.
- The location of the gas inlet is shown below
- A manual shutoff valve is required for installation (it must be located within 3' (915mm) of the heater). T-Handle gas cocks are required in Massachusetts in compliance with code 248CMR.
- This stove is shipped with a 24" (610) long, 3/8" (10mm) diameter flex gas line attached to an elbow on the gas control valve (see illustration below for location). The flex gas line accepts a 3/8" flare fitting.

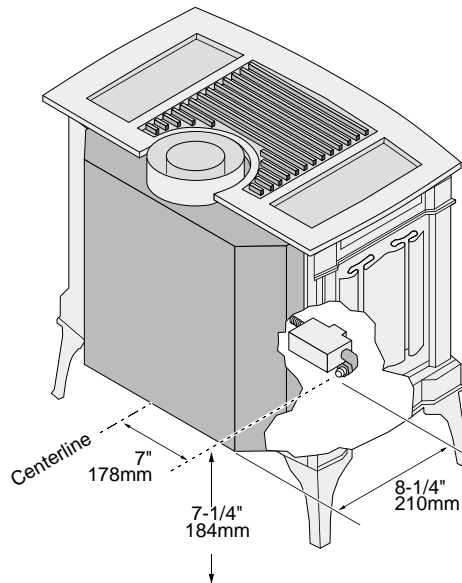

### Gas Inlet Pressure

<b>Gas Pressure</b>	Max. Input Pressure	Min. Input Pressure	Max. Manifold Pressure	Min. Manifold Pressure
<b>Natural Gas</b>	7" W.C. (1.74 kPa)	5.5" W.C. (1.37 kPa)	3.5" W.C. (0.87 kPa)	1.6" W.C. (0.40 kPa)
<b>Propane</b>	13" W.C. (3.23 kPa)	11" W.C. (2.74 kPa)	11" W.C. (2.74 kPa)	2.9" W.C. (0.72 kPa)

- If the pressure is not sufficient, make sure the piping used is large enough, the supply regulator is adequately adjusted, and the total gas load for the residence does not exceed the amount supplied.
- The supply regulator (the regulator that attaches directly to the residence inlet or to the propane tank) should supply gas at the suggested input pressure listed above. Contact the local gas supplier if the regulator is at an improper pressure.

#### Directions for Connecting a Gas Pressure Test Gauge

The gas control valve (shown to the right) has two test ports for testing input (line pressure) and output (manifold) pressure. Loosen the brass screw on either test port and place a 5/16" i.d. rubber or plastic tube over the tapered test port. Connect the tube to the test gauge.

**WARNING:** The brass screw must be tightened after testing to prevent gas leakage.

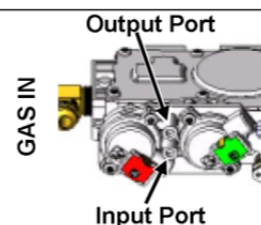

## Vent Requirements

- The gas appliance and vent system must be vented directly to the outside of the building, and never be attached to a chimney serving a separate solid fuel or gas-burning appliance. Each direct vent gas appliance must use its own separate vent system.
- In addition to the requirements listed here, follow the requirements provided with the vent.
- When the vent passes through a wall a wall thimble is required. When the vent passes through a ceiling a support box or firestop is required. When the vent passes through the roof, a roof flashing and storm collar are required. Follow the instructions provided with the vent for installing these items. NOTE: Wall thimbles may have different dimensions than what is required by this heater.
- The vent must maintain the required 1" (26mm) clearance to combustible materials to prevent a fire. Do not fill air spaces with insulation.

## Altitude Considerations

- Failure to adjust the air shutter properly may lead to improper combustion which can create a safety hazard. Consult your dealer or installer if you suspect an improperly adjusted air shutter.
- This heater has been tested at altitudes ranging from sea level to 6,000 feet (1,800 M). In this testing we have found that the heater, with its standard orifice, burns correctly with just an air shutter adjustment.

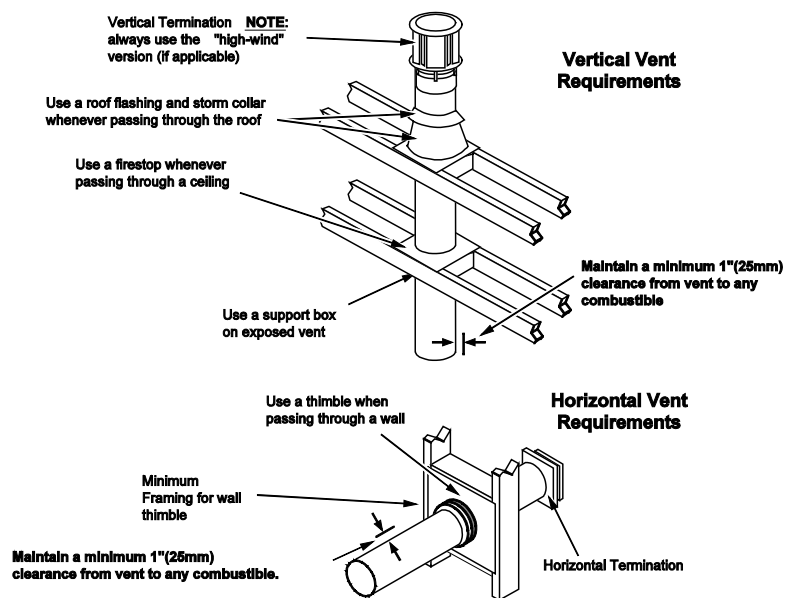

## Approved Vent

- Use 6-5/8" (168mm) diameter Simpson Dura-Vent Direct-Vent Pro (or GS)\*.
  - \* Other vent may be approved with this stove. Check with the vent manufacturer for details.
- Always use the high-wind cap (or high-wind scone cap, part # 46DVA-HSCH).
- Installation instructions for Simpson Dura-Vent may be found at [www.duravent.com](http://www.duravent.com)

## Vent Installation

- Slide the vent sections together and turn 1/4 turn until the sections lock in place.
- Screws are not required to secure the vent. However, three screws may be used to secure vent sections together if desired.
- High temperature sealant is recommended at the appliance starter section connection (use high-temperature silicone or Mill-Pac®).
- If disassembly is required, at time of re-assembly check to see if the vent creates a tight fit. If it does not, apply high temperature sealant to the joints of the affected sections.
- Horizontal sections require a 1/4" (7mm) rise every 12" (305mm) of travel
- Horizontal sections require non-combustible support every three feet (e.g.: plumbing tape)

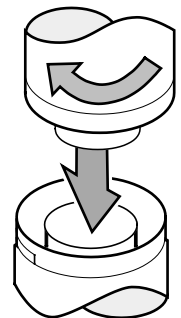

## Approved Vent Configurations

### Restrictor Position

- A restrictor is built into the appliance to control the flow rate of exhaust gases. This ensures proper flames for the wide variety of vent configurations. Depending upon the vent configuration, you may be required to adjust the restrictor position. The charts for approved vent configurations describe which position the vent restrictor must be in.

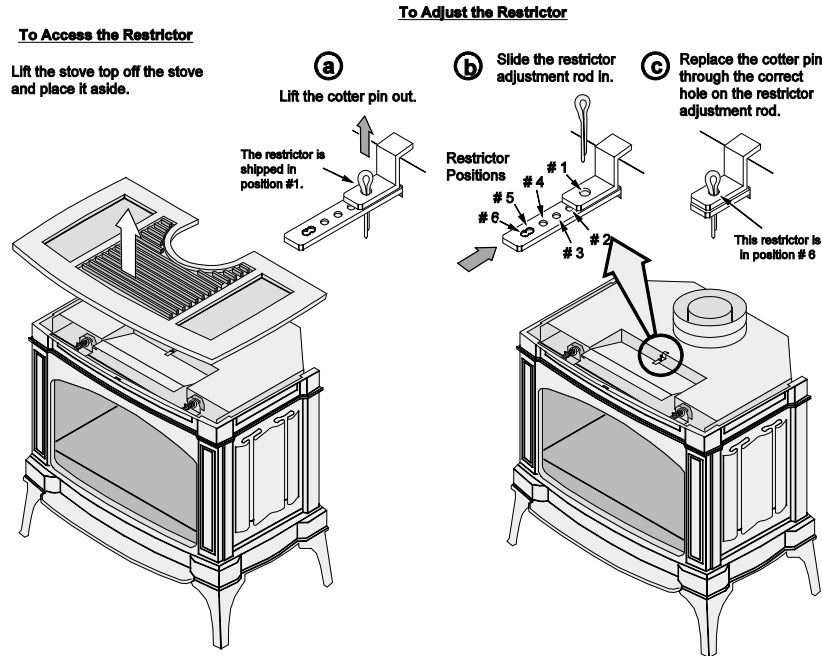

### Measuring Vent Lengths

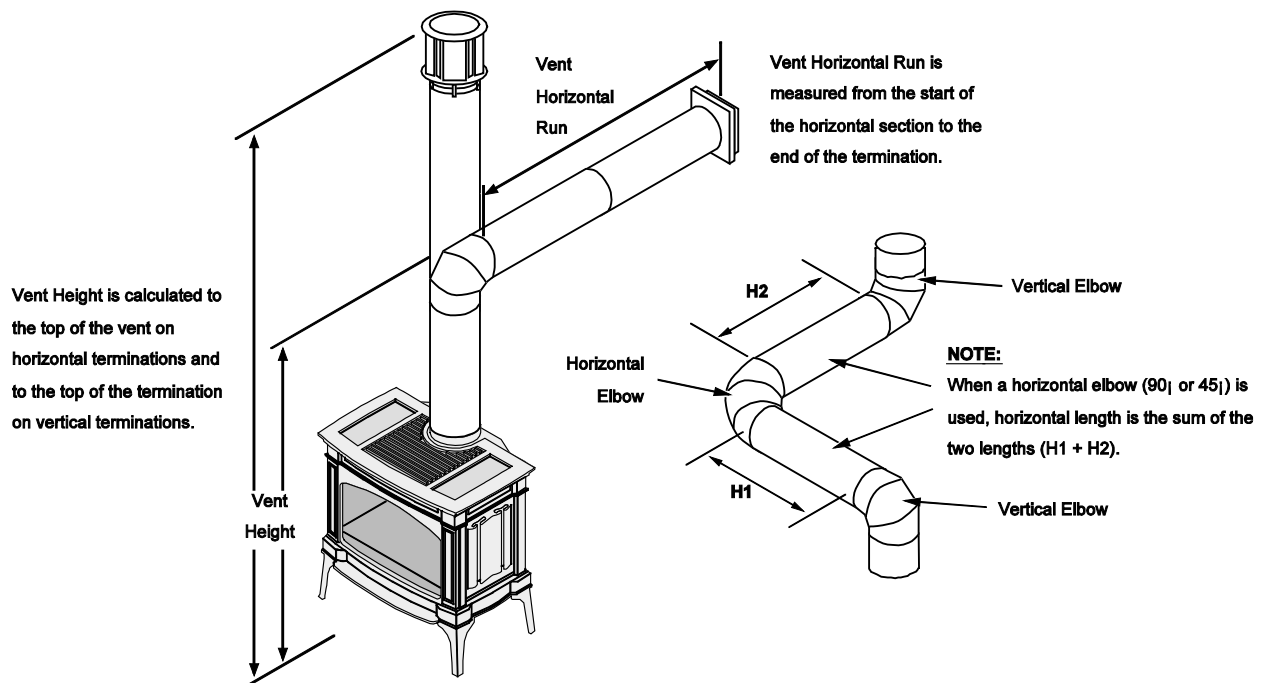

## Vertical Terminations with Zero, Two, or Four 45° Elbows

- 10' (3.1M) Minimum System Height (with or without offsets)
- 40' (12.2M) Maximum System Height
- 24' (7.3M) Maximum Offset
- The termination must fall within the shaded area shown in the chart. Use the indicated restrictor position.

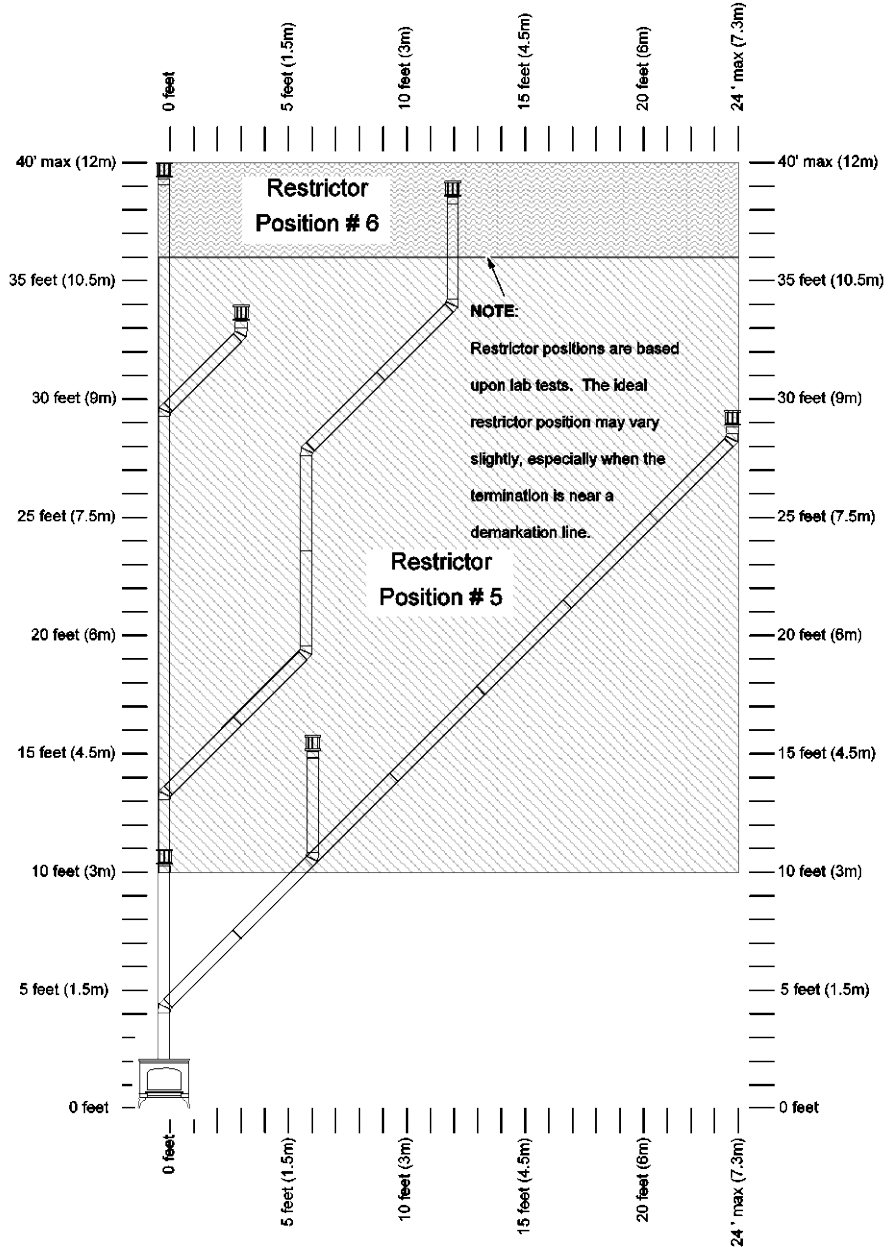

## Horizontal Termination with One 90° Elbow

- If using a Snorkel Termination (14" (356mm) or 36" (915mm)) add the snorkel height to the vertical height (snorkel terminations are used primarily for basement installations).
- The termination must fall within the shaded area shown in the chart. Use the indicated restrictor position.

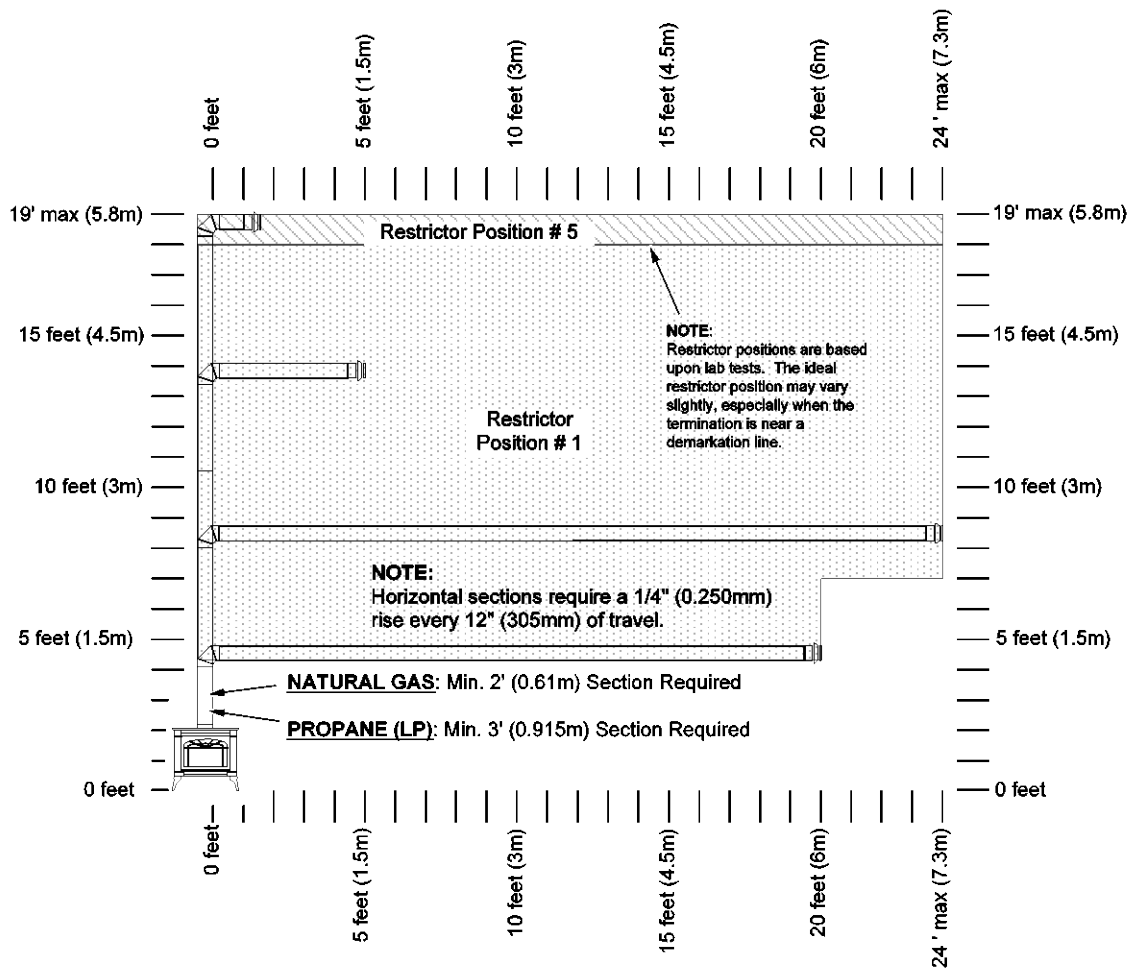

## Horizontal Termination with Two Elbows (one 90° vertical and one 90° or 45° horizontal elbow)

- If using a Snorkel Termination (14" (356mm) or 36" (915mm)) add the snorkel height to the vertical height (snorkel terminations are used primarily for basement installations).
- The termination must fall within the shaded area shown in the chart. Use the indicated restrictor position.

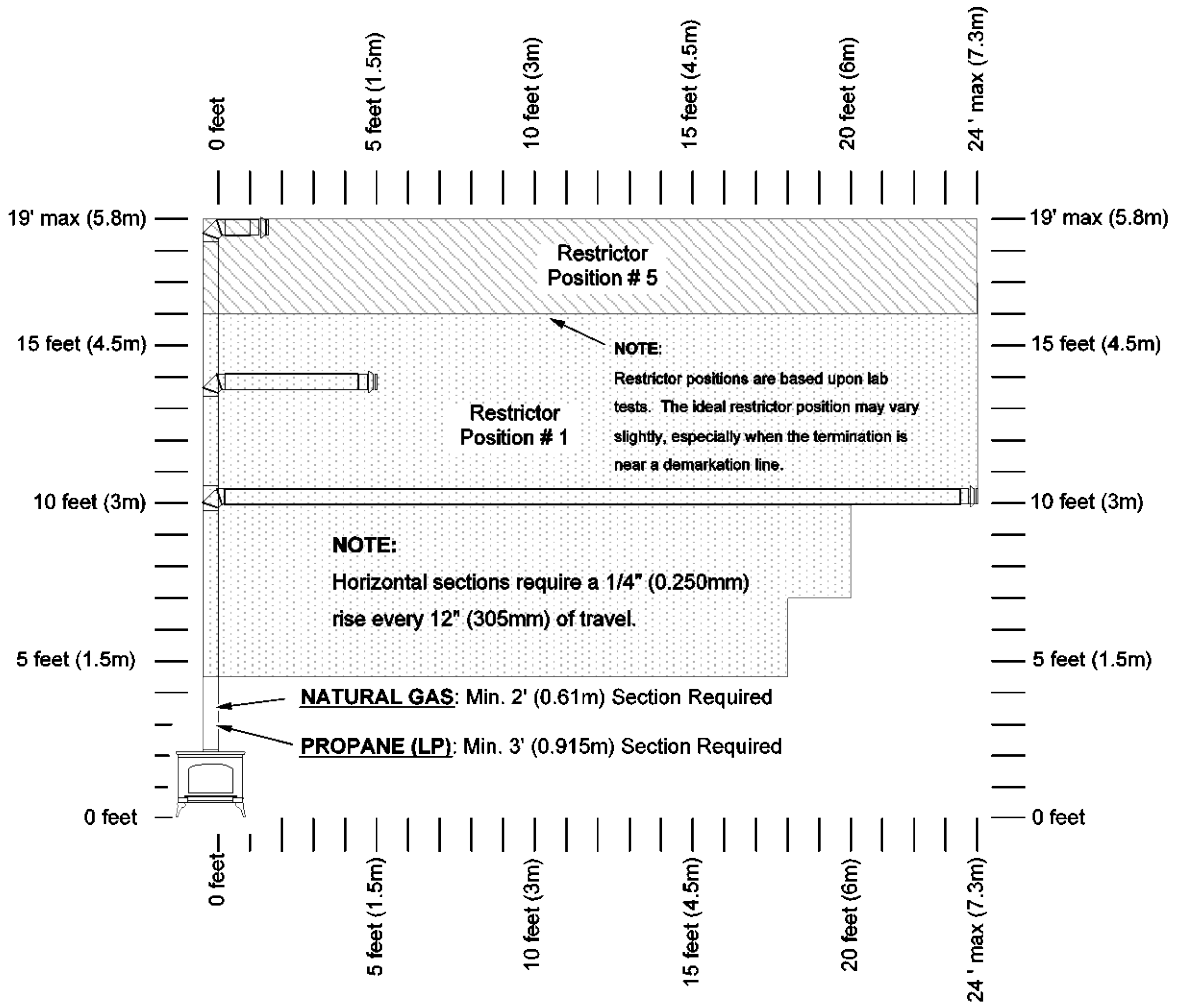



## Horizontal Termination with Three 90° Elbows (all vertical)

- If using a Snorkel Termination (14" (356mm) or 36" (915mm)) add the snorkel height to the vertical height (snorkel terminations are used primarily for basement installations).
- The termination must fall within the shaded area shown in the chart. Use the indicated restrictor position.

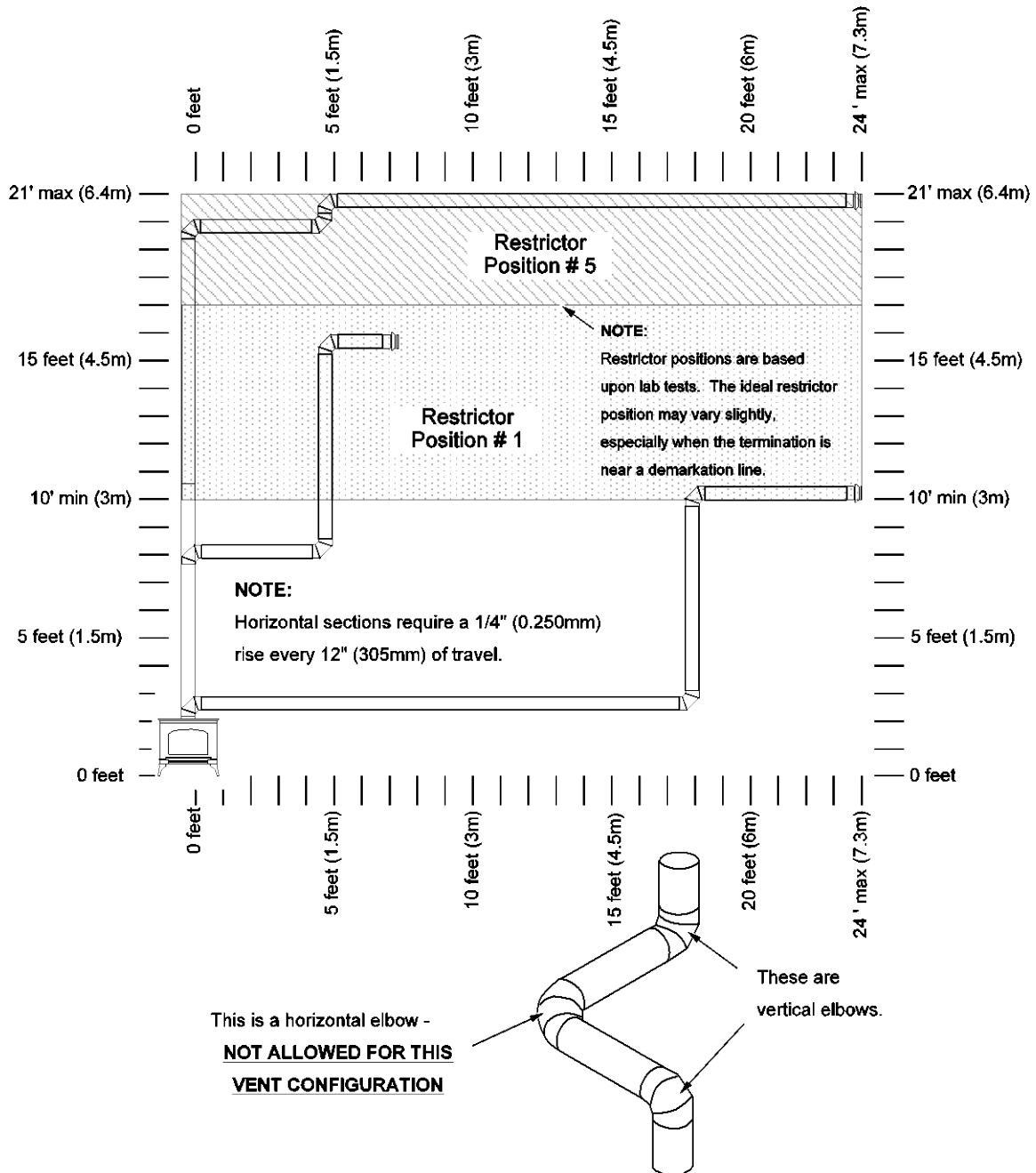

## Vertical Terminations with Two 90° Elbows

- The termination must fall within the shaded area shown in the chart. Use the indicated restrictor position.

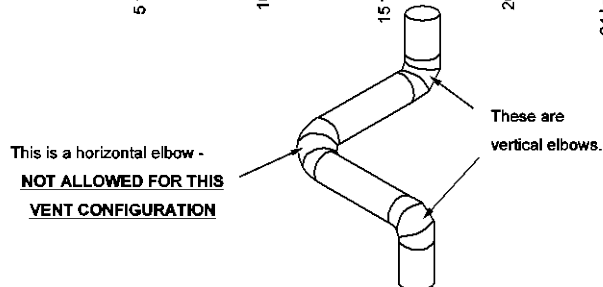
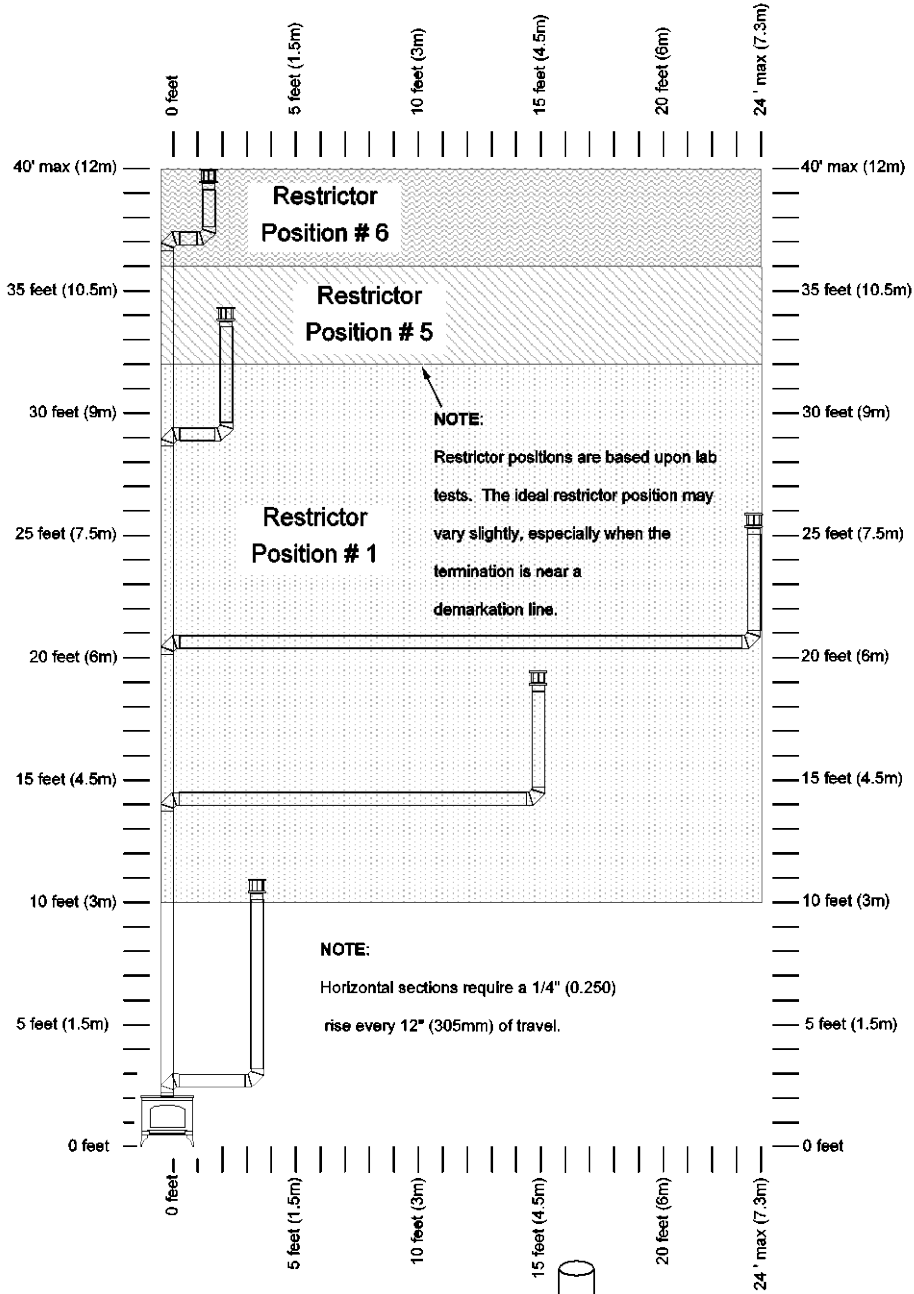

## Vertical Terminations with Three 90° Elbows (Two 90° Vertical and One 45° or 90° Horizontal Elbow)

- The termination must fall within the shaded area shown in the chart. Use the indicated restrictor position.

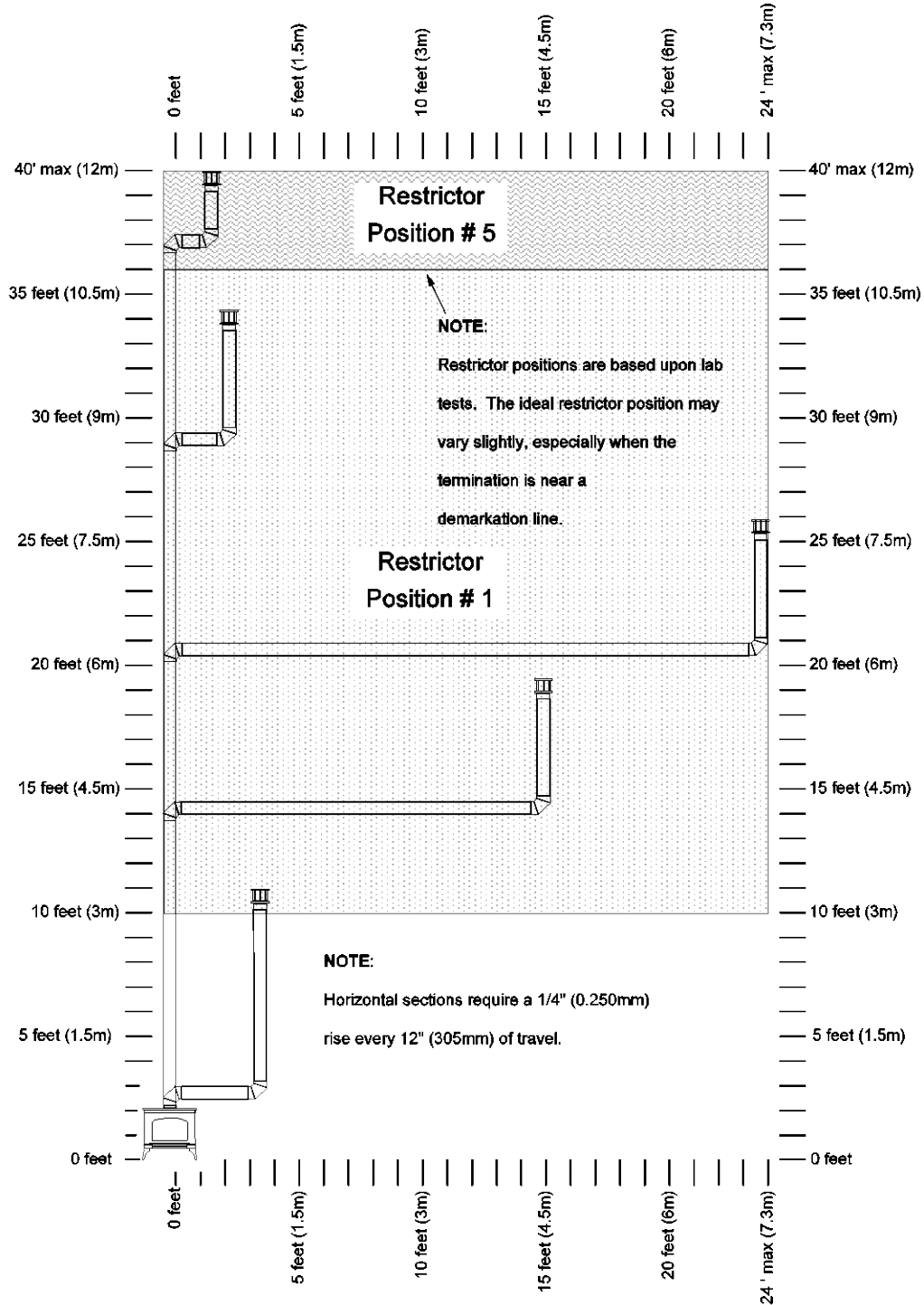

## Vent Termination Requirements *(see illustration below)*

### ! Venting terminals shall not be recessed into a wall or siding.

- A Minimum 9" (229mm) clearance from any door or window
- B Minimum 12" (305mm) above any grade, veranda, porch, deck or balcony
- C Minimum 1" (25mm) from outside corner walls  
**NOTE:** Clearance in accordance with local installation codes and the requirements of the gas supplier.
- D Minimum 12" (305mm) from inside corner walls  
**NOTE:** Clearance in accordance with local installation codes and the requirements of the gas supplier.
- E Minimum 11" (279mm) clearance below unventilated soffits or roof surfaces  
 Minimum 18" (457mm) clearance below ventilated soffits  
 Minimum 6" (152mm) clearance below roof eaves  
**NOTE:** Vinyl surfaces require 24" (610mm)  
**NOTE:** Clearance in accordance with local installation codes and the requirements of the gas supplier.
- F Minimum 12" (305mm) clearance below a veranda, porch, deck or balcony  
**NOTE:** Permitted only if veranda, porch, deck, or balcony is fully open on a minimum of two sides beneath the floor.  
**NOTE:** Clearance in accordance with local installation codes and the requirements of the gas supplier.
- G Minimum 48" (1219mm) clearance from any adjacent building
- H Minimum 84" (2134mm) clearance above any grade when adjacent to public walkways or driveways  
**NOTE:** may not be used over a walkway or driveway shared by an adjacent building
- I Minimum 9" (229mm) clearance to any non-mechanical air supply inlet to the building or the combustion air inlet to any other appliance.
- J Minimum 36" (914mm) clearance above any mechanical air supply inlet if within 10' (3M) horizontally
- K Minimum 36" (914mm) from the area above the meter/regulator (vent outlet) - this extends 15' (4.5M) above the regulator  
**NOTE:** Clearance in accordance with local installation codes and the requirements of the gas supplier.
- L Minimum 36" (914mm) from the meter/regulator (vent outlet)  
**NOTE:** Clearance in accordance with local installation codes and the requirements of the gas supplier.
- M Minimum 12" (305mm) above the roof line (for vertical terminations)
- N Minimum 24" (610mm) horizontal clearance to any surface (such as an exterior wall) – for vertical terminations

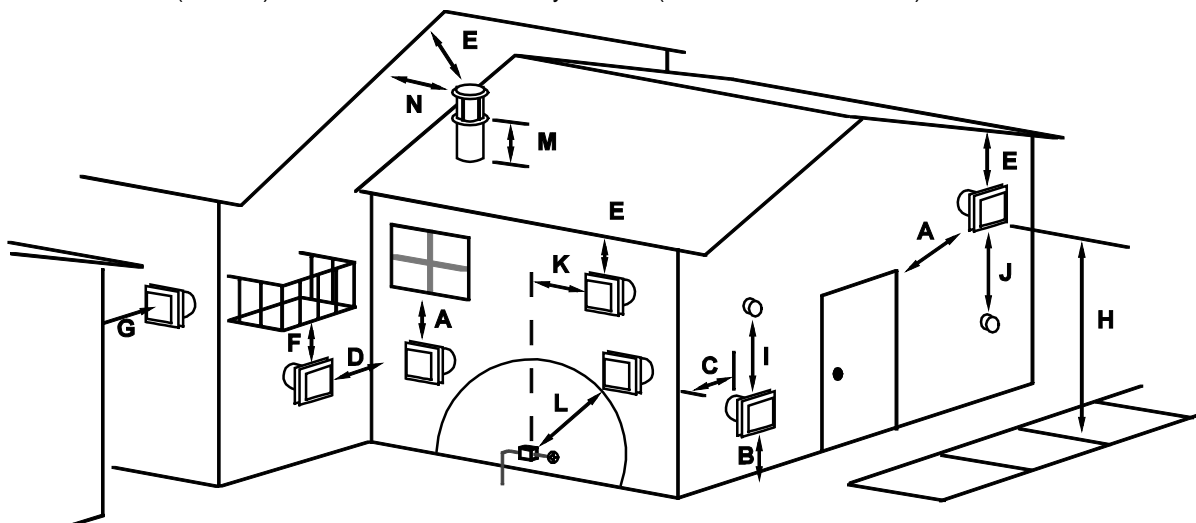
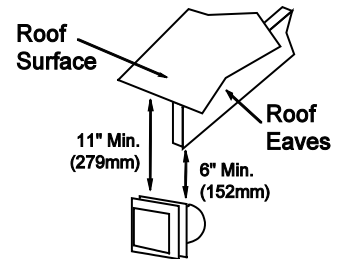

### **NOTE: Measure clearances to the nearest edge of the exhaust hood.**

- Use the vinyl siding standoff when installing on an exterior with vinyl siding.
- Vent termination must not be located where it will become plugged by snow or other material

## Class A Chimney Conversion Kit

Simpson DuraVent provides a conversion kit for those wishing to use an existing wood stove chimney to vent this direct vent stove. The illustration below gives an overview of this type of installation. See the instructions included with the kit for details.

- ! Do not exceed the maximum vertical rise (see the section "Approved Vent Configurations" starting on page 13) allowable. Remember to set the restrictor position to the correct position (based upon the vertical rise height - see the chart on page 14).
- ! The conversion kit does not work on interior masonry chimneys.

### Chimney Conversion Kit A (# 931)

Metalbestos 6" I.D.  
Security Chimneys 6" I.D.  
Jacks-Evans 6" I.D.  
Hart & Cooley 6" I.D.  
Pro-Jet 6" I.D.

### Chimney Conversion Kit B (# 932)

Simpson Dura-Vent 6" I.D.  
Air-Jet 6" I.D.  
Metal-Fab 6" and 7" I.D.  
Amer. Metals 6" & 7" I.D.  
Metalbestos 7" and 8" I.D.  
Jacks-Evans 7" and 8" I.D.  
Hart & Cooley 7" and 8" I.D.  
Pro-Jet 7" and 8" I.D.  
Security Chimneys 8" I.D.

### Chimney Conversion Kit C (# 933)

Simpson Dura-Vent 7" and 8" I.D.  
American Metals 8" I.D.  
Air-Jet 8" I.D.  
Metal-Fab 8" I.D.  
American Metals 8" I.D.

### Each Kit Contains:

Retro Connector  
Retro Vertical Top

### Additional Required Equipment:

4" Flex (#711 or U.L. 1777)  
Termination (#991)  
Co-Axial Sections

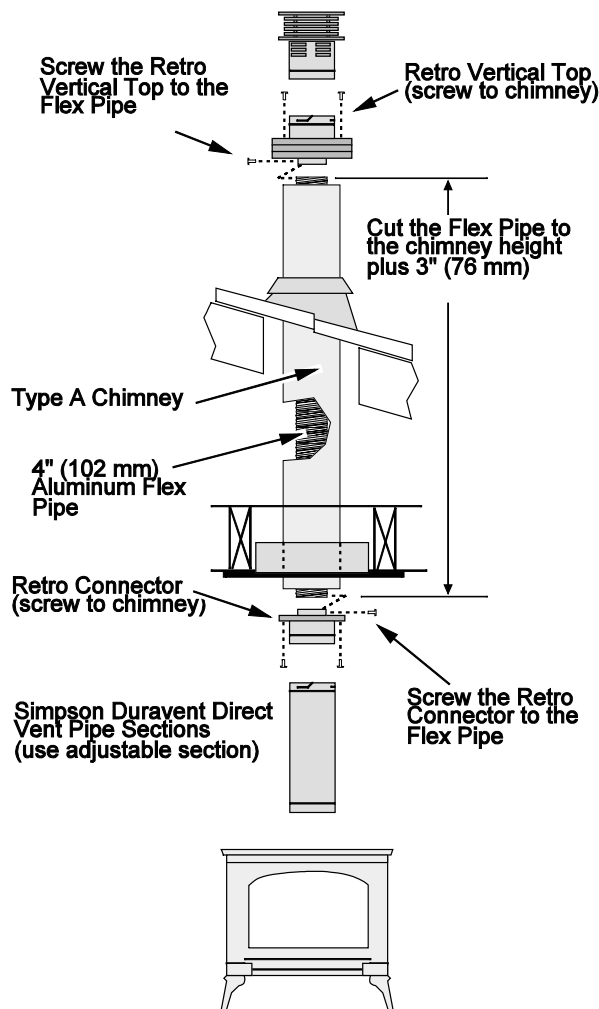

## Interior Masonry Chimney Conversions

- Follow the requirements and use the equipment listed in the illustration below to install this appliance into an interior masonry chimney.
- Maximum vertical rise is 40' (12M)
- Minimum vertical rise is 10' (3M)
- See the chart on page 18 for determining the correct restrictor position.  
**NOTE:** these restrictor positions are based upon lab tests. The ideal restrictor position may vary slightly.

### Interior Masonry Chimney

The entire chimney system must be air-tight. Make sure to seal the flashing, clean-out, and thimble connection, and to inspect the chimney.

Make sure the coaxial pipe maintains a 1" clearance to any combustible. The vent must be sealed air-tight.

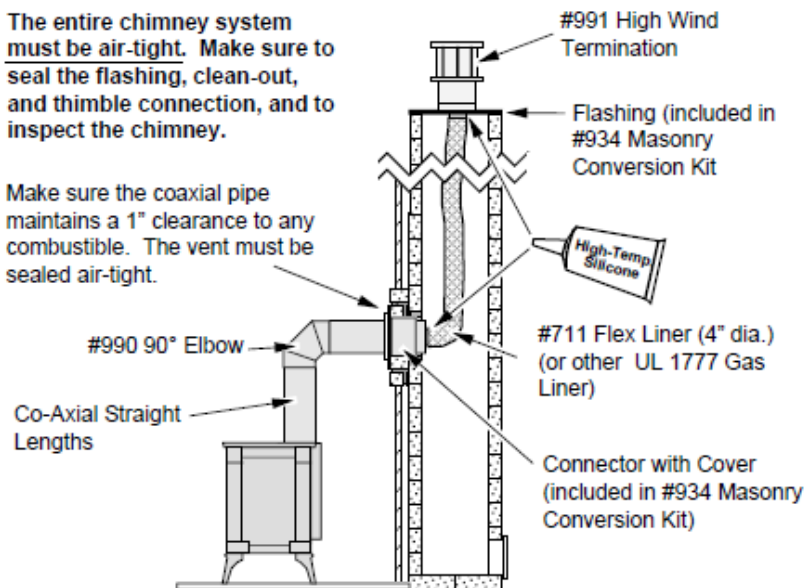

### Standard Masonry Fireplace

The entire chimney system must be air-tight. Seal the connector cover and inspect the chimney.

Make sure the coaxial pipe maintains a 1" clearance to any combustible. The vent must be sealed air-tight.

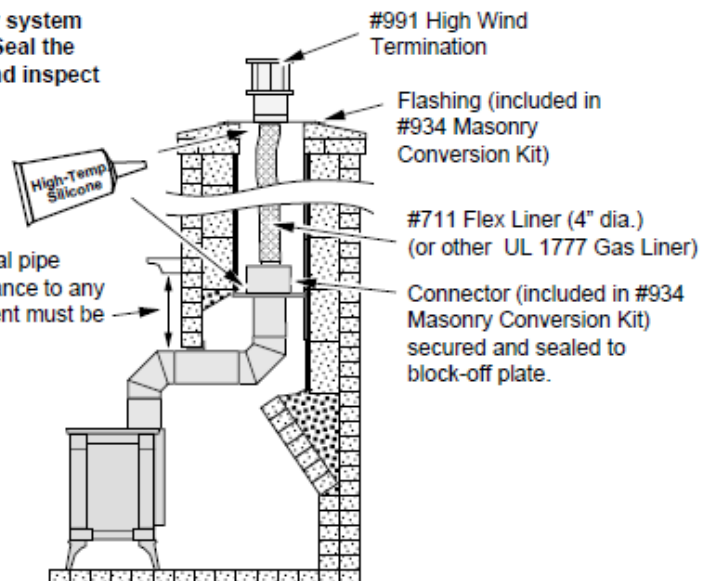

## Steps for Finalizing the Installation

1. Remove the glass (see page 25).

**NOTE:** If using propane (LP) convert the appliance prior to installing the logs.

2. We recommend you purge the gas line at this time (with the glass removed). This allows gas to be detected once it enters the firebox, ensuring gas does not build up.
3. Make sure the accent light bulb is in place.

**NOTE:** Take care to not touch the bulb with your fingers – use a cloth or paper towel).

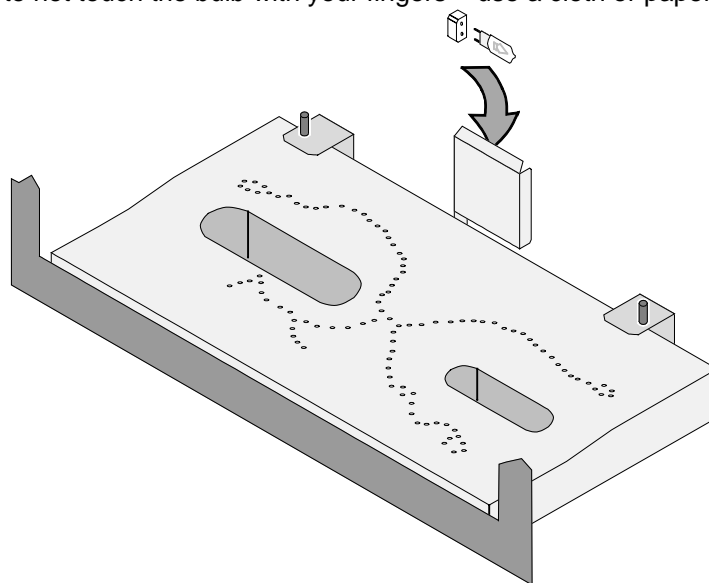

4. Install the four AA batteries (included in the owner's pack) into battery holder (see the illustration below). The AA batteries act as a power backup in case the household (AC) power goes out. Install the 9v battery (included in the owner's pack) into control panel light assembly (see the illustration below). The battery holder is held in place with Velcro and may be removed for easier access.

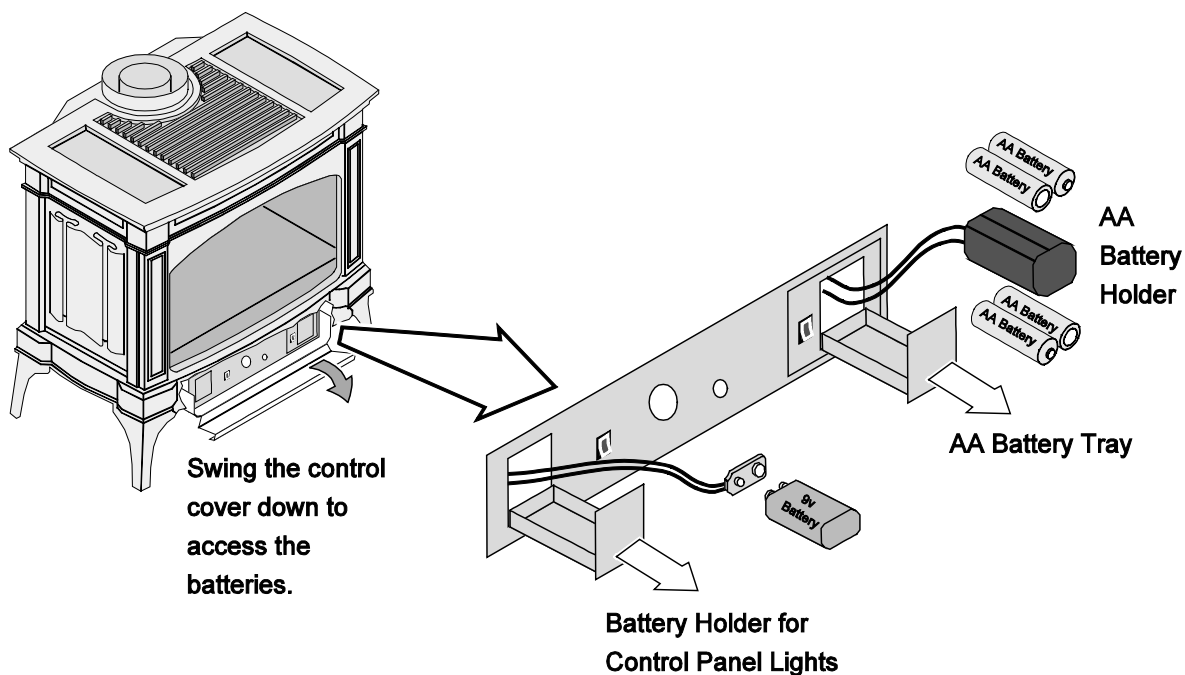

5. Install the logs (see page 27).
6. Replace the glass.
7. Start the heater.
8. Leak test all gas joints.
9. Check the air shutter following the directions below.

## Air Shutter Adjustment

Let the heater burn for fifteen minutes (make sure the logs and glass are in place). The flames should be yellow with no sooting. Adjust the air shutter, if necessary, to achieve the correct looking flame.

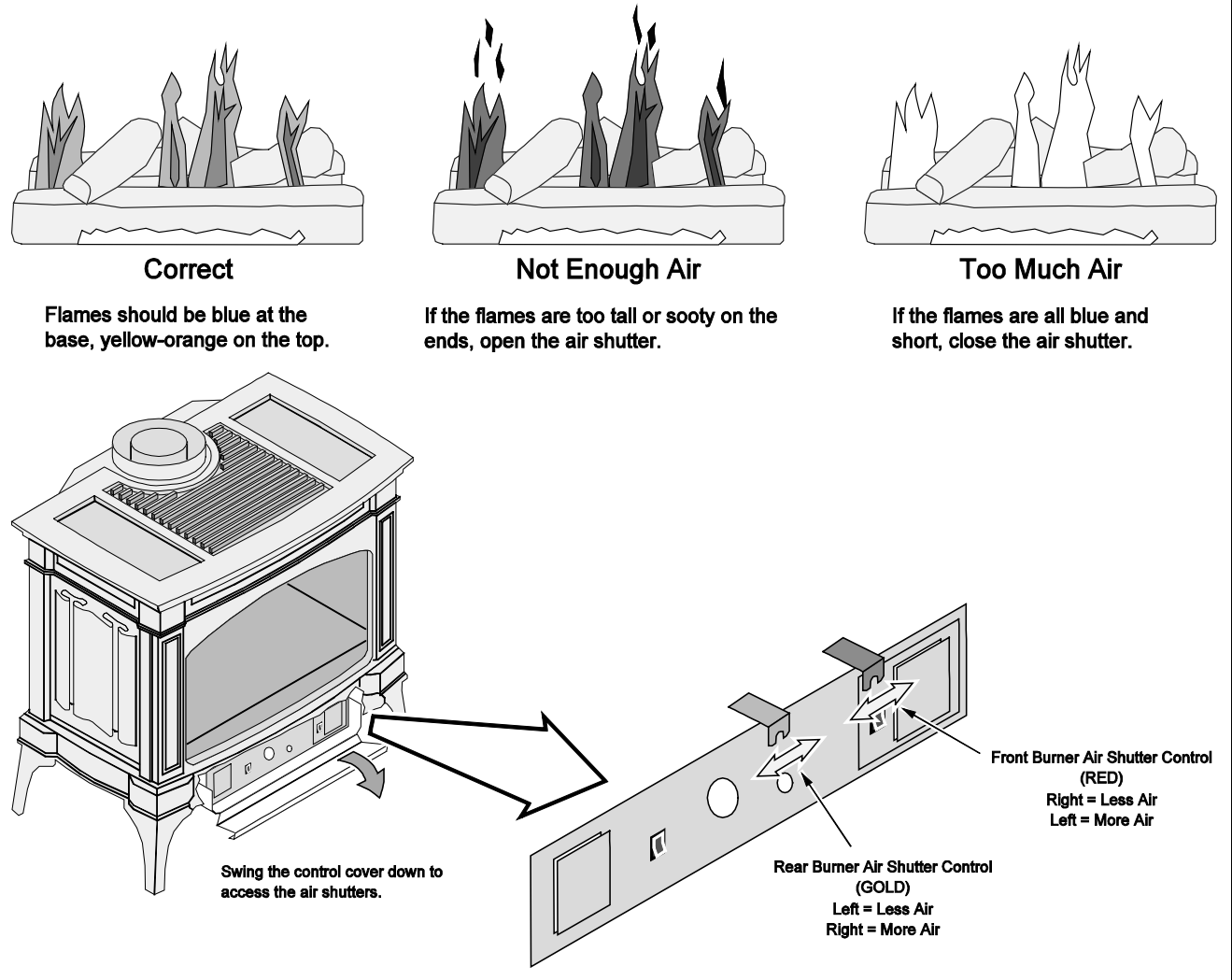

10. Turn the flame adjust knob to its highest position - the flames should not contact the top of the firebox. Check the flame on low position. The flames should burn off of each burner hole. If the heater does not work correctly, contact your Travis dealer for a remedy.
11. Give this manual to the home owner for future reference and fully explain operation of this heater.



## Face and Glass Removal



A barrier designed to reduce the risk of burns from the hot viewing glass is provided with this appliance and shall be installed for the protection of children and other at-risk individuals.



If the barrier becomes damaged, the barrier shall be replaced with the manufacturer's barrier for this appliance.



The appliance must be completely cool before removing the glass.  
Do not strike or slam the glass.

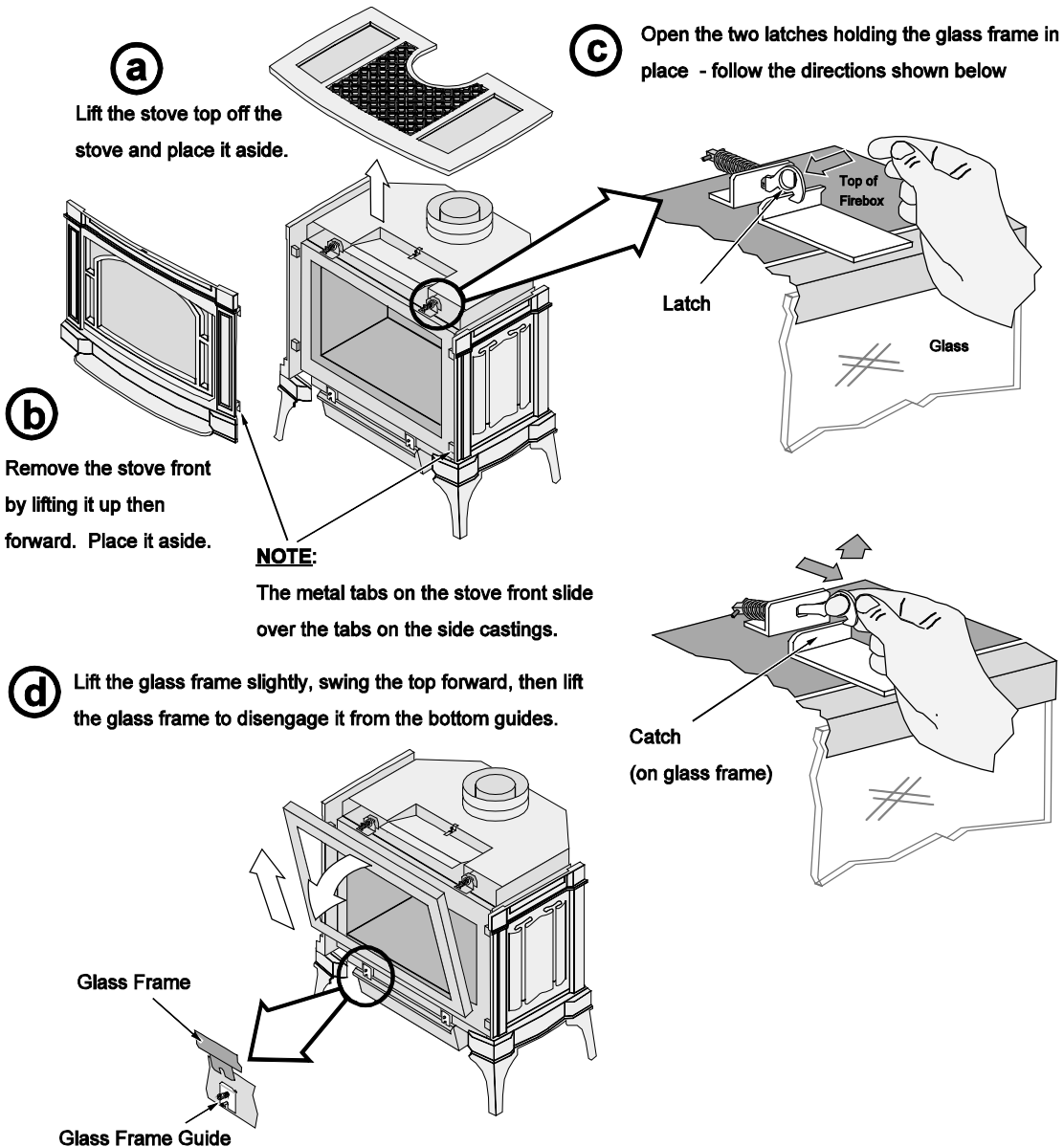

**a** Lift the stove top off the stove and place it aside.

**b** Remove the stove front by lifting it up then forward. Place it aside.

**NOTE:**  
The metal tabs on the stove front slide over the tabs on the side castings.

**d** Lift the glass frame slightly, swing the top forward, then lift the glass frame to disengage it from the bottom guides.

### Re-Attaching the Glass Frame:

- a) Slide the two brackets on the bottom of the glass frame into the glass frame guides (hold the glass frame at a slight angle).
- b) Swing the glass frame into place - you may have to lift it slightly to allow it to fit over the top of the firebox.
- c) Attach the upper latches (follow the instructions above in reverse).

## Glass Frame Removal and Installation (continued)

The latch can come loose from glass frame anchor. This occurs when it is turned 1/4 turn when it is disengaged. Follow the directions below to re-install the latch if it becomes loose.

**Hold the latch at an angle and insert it into the slot on the glass frame anchor.**

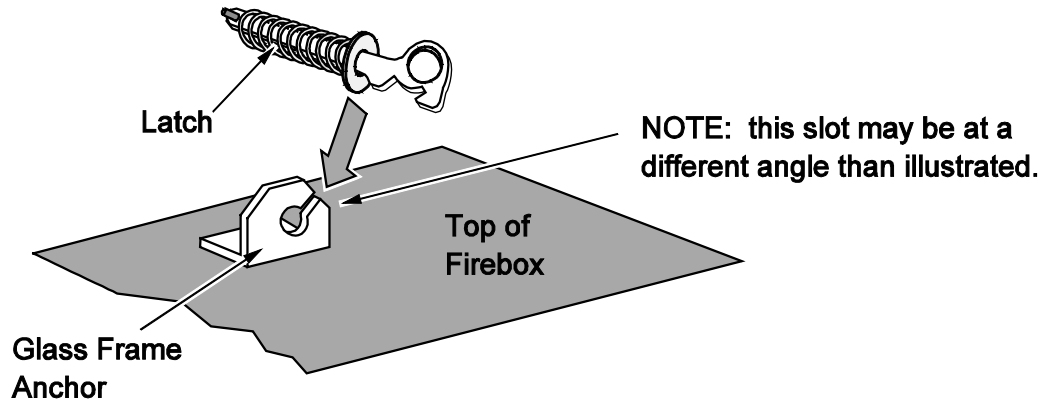

**Note how the washer on the latch fits behind the flange on the glass frame anchor.**

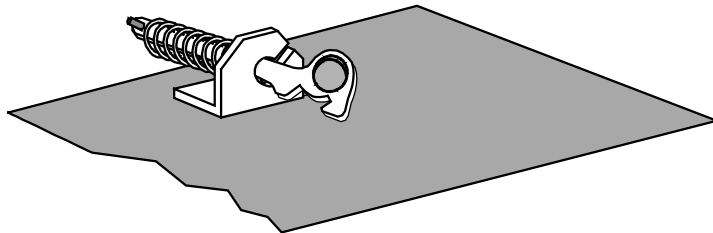

**Once fully inserted, turn the latch until it is upright.**

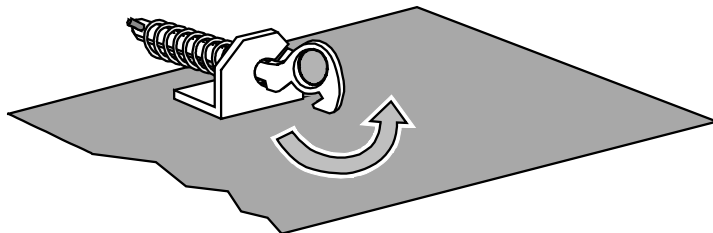

## Log Installation

- ! **The logs are fragile, especially after being exposed to heat.**
- Make sure the gas control valve is "OFF" and the heater is cool prior to conducting service.
- Failure to position the parts in accordance with these diagrams or failure to use only parts specifically approved with this appliance may result in property damage or personal injury.
- If using propane (LP), convert the appliance before installing the logs (see page 42).
- The burner must be correctly positioned before installing the logs. Make sure the burner is fully seated and the pilot is properly aligned. See page 42 for details on burner removal.

### Rear Log Placement

The rear log has two holes on the bottom. Place the log so the pins on the burner insert into the holes on the log (see photos below).

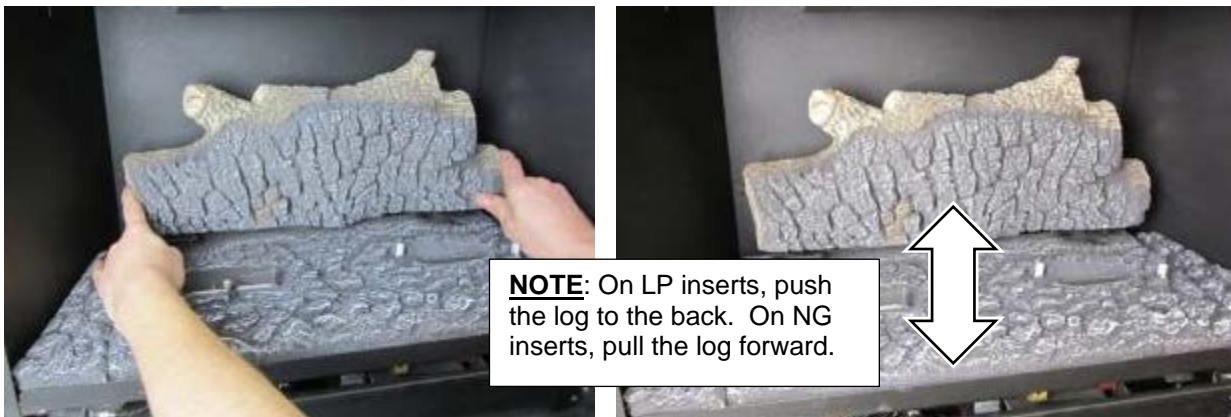

## Left Front Log Placement

The left front log has two holes on the bottom. Place the log so the pin on the burner and the metal bracket insert into the holes on the log (see photos below).

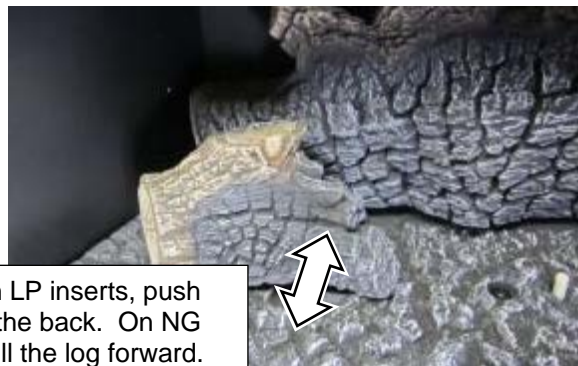

**NOTE:** On LP inserts, push the log to the back. On NG inserts, pull the log forward.

## Right Twig Placement

Place the right twig on the burner as shown below. Make sure it does not cover any burner holes.



## Right Front Log Placement

The right log has two holes on the bottom. Place the log so both burner pins insert into the holes on the log (see photos below). Make sure the log is pushed back so it sits flat.

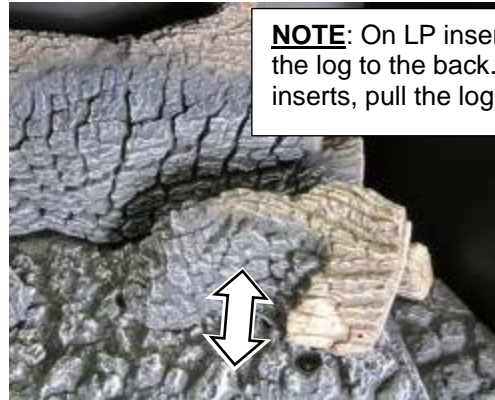
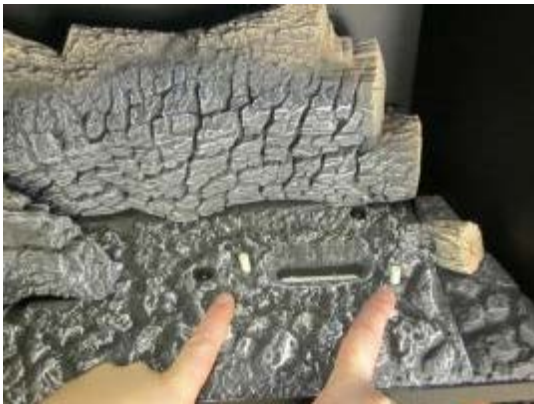

**NOTE:** On LP inserts, push the log to the back. On NG inserts, pull the log forward.



## Left Cross Log Placement

Place left cross log as shown below. Note- how the log rests on the flat spots of the back and left logs.



# 30 Finalizing the Installation (for qualified installers only)

## Right Cross Log Placement

Place the log as shown below. The right cross log rests on the flat spots of the rear and the right front logs.

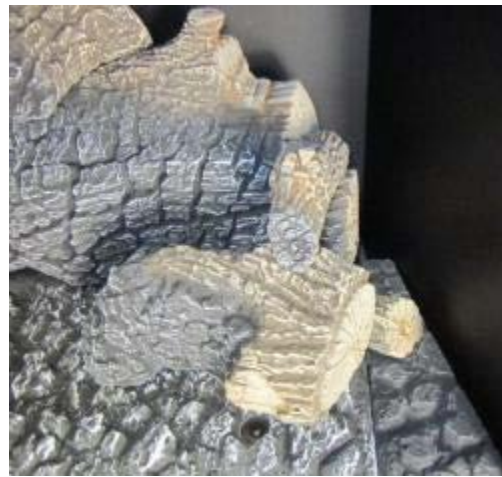

## Left Twig Placement

Place the left twig on the burner as shown below. Make sure it does not cover any burner holes.



## Center Twig Placement

Place the center twig on the burner as shown below. Make sure it does not cover any burner holes.



The completed installation is shown below.



## Ember Placement

Place a layer of embers along any screw heads and visible edges of the burner.



## Rockwool Installation

The included rock wool is placed on top of the burner to enhance the glow from the burner. **The rock wool works best when it is applied in a very thin, porous layer.** The best method for applying the rock wool is to brush it on to the burner. Compress a clump of rock wool between your thumb and forefinger. Use a stiff brush to apply a thin layer of rock wool fibers onto the burner. Do not use the entire bag of rock wool. Use only a small amount and save the remainder. Over-use of rock wool will diminish the glow and may cause sooting or other adverse conditions.

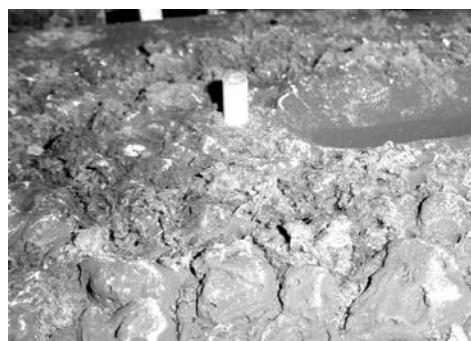



## Before You Begin

**Warning:** Read this entire manual before you use your new stove (especially the section "Safety Precautions" on pages 4 & 5). Failure to follow the instructions may result in property damage, bodily injury, or even death.

**Warning:** Do not operate appliance with the glass front removed, cracked or broken. Replacement of the glass should be done by a licensed or qualified service person.

## Location of Controls - See explanation below

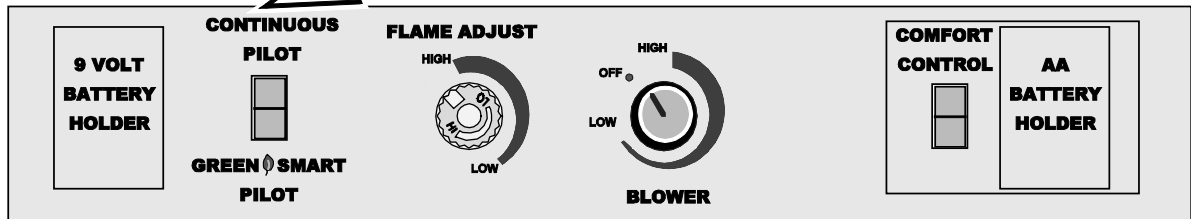
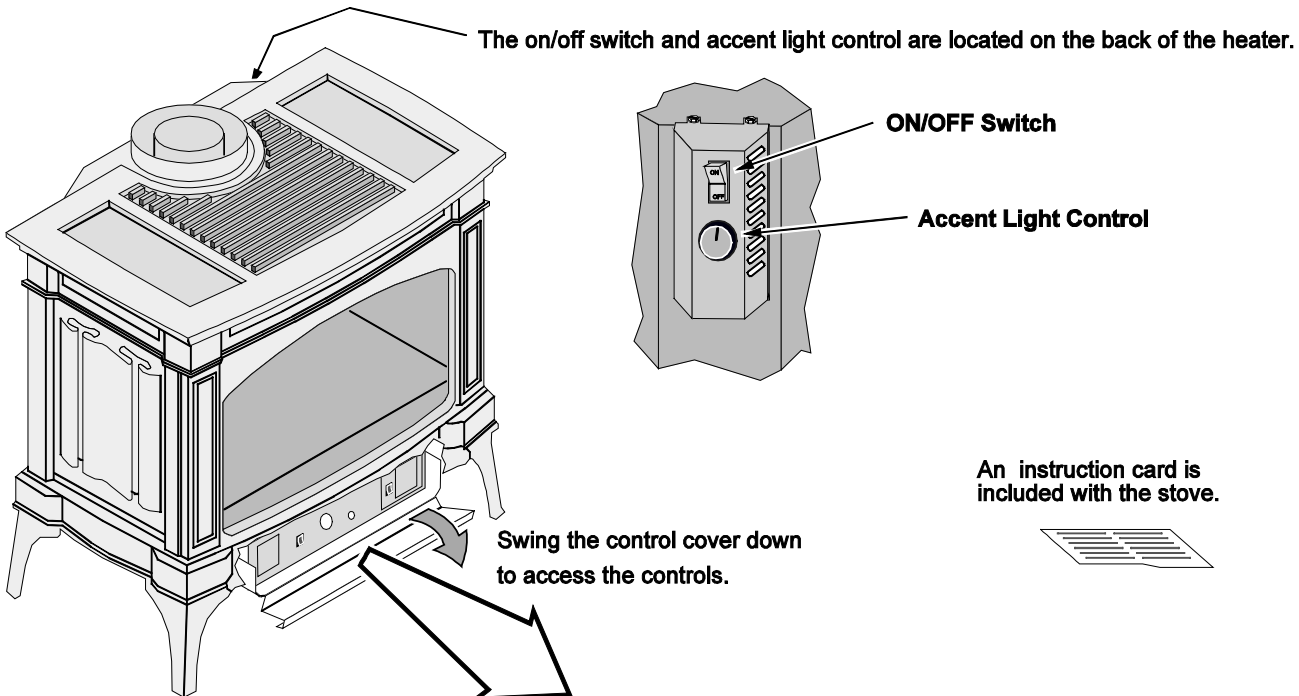

<b>Optional Blower Control</b>	This knob controls the speed of the optional internal convection blower that pushes heated air into the room.
<b>Accent Light</b>	This knob controls the accent lights located behind the logs.
<b>Flame Adjust Knob</b>	This knob controls the flame height from low ("LO") to high ("HI").
<b>Continuous Pilot -- GreenSmart Pilot</b>	This switch controls how the pilot flame works. See the section "Continuous Pilot / GreenSmart Pilot" for details.
<b>Comfort Control</b>	This switch turns the rear burner on and off.
<b>AA Battery Holder</b>	This holder contains 4 AA batteries that allow the stove to operate during power outages.
<b>Main Burner</b>	This switch turns the stove burners on and off.

### ***Starting the Stove for the First Time***

- Burn the heater at a high setting with the blower off for an extended period (up to 48 hours). This will cure the painted surfaces. **Fumes** from the paint curing and oil burning off the steel will occur. This is normal. We recommend opening a window to vent the room.
- **Condensation** may appear on the glass each time you start the stove - this is normal.
- **Blue Flames** will occur on the stove when it first comes on. After fifteen minutes the flames will turn a more realistic yellow and orange color.
- Certain installations use a remote, thermostat, or wall switch to turn the stove on and off. If this is the case, leave the ON/OFF switch "ON".
- Verify the power backup and control light batteries are installed (see page 37).

### ***Turning the Stove On and Off***

Use the main burner switch to turn the main burner on and off.

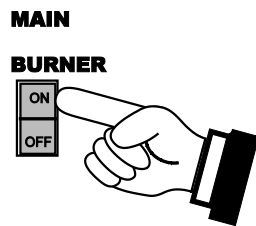

#### **NOTE FOR REMOTES, THERMOSTATS, OR WALL SWITCHES:**

The on/off switch on the stove may be required to be left in the ON or OFF position for the stove to operate. Consult your installer or dealer for details.

- Do not place any combustible items on top of or directly in front of the stove, even temporarily. An optional thermostat may start the stove causing a combustible item to ignite.
- If the stove turns on and off frequently while using a standard thermostat, you may want to adjust the flame height down until it produces just enough heat needed.

### ***Comfort Control***

The rear portion of the burner may be shut off to lower the heat output and flame size from the burner (this is called the comfort control). Use the comfort control switch to adjust this as desired.

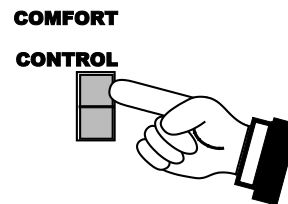

### ***Adjusting the Flame Height***

This stove has an adjustable flame to tailor the look and heat output to your specific needs. It is adjusted by turning the flame adjust knob.

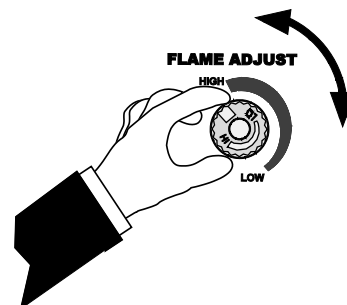

## Accent Light

This stove has a built-in accent light that may be turned on and off and dimmed to your preference. Turn the knob to achieve the desired light output.

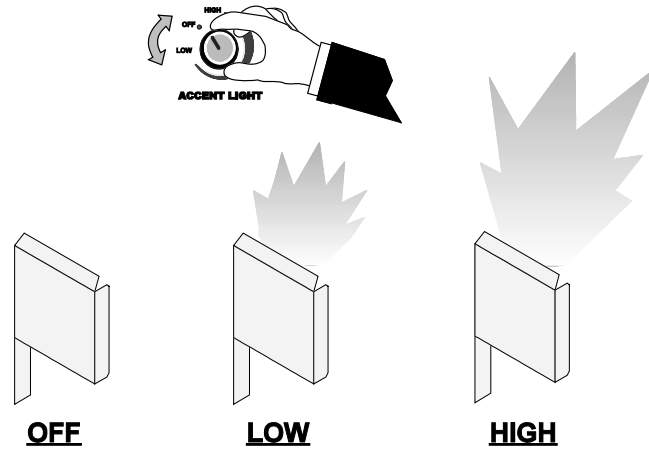

## Adjusting the Optional Blower Speed

The blower helps transfer heat from the heater into the room. It will not turn on until the heater is up to temperature (approximately 15 minutes after starting). See the illustration below for instructions on adjusting the blower speed.

**NOTE:** With the rear burner off (comfort control), the heater may not become hot enough for the blower to turn on.

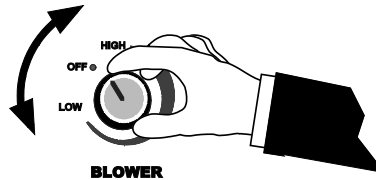

## Continuous Pilot / GreenSmart™ Pilot Switch

This stove may run with the pilot continuously running or in GreenSmart (intermittent) mode. For most homeowners, the GreenSmart mode is preferred (this saves fuel, doesn't give off un-needed heat). However, in some situations the homeowner may prefer to switch the stove to continuous pilot. The most typical reasons for switching to continuous pilot are:

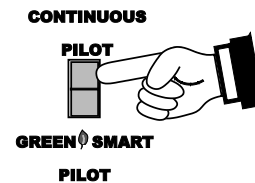

- Very Cold Conditions – in very cold conditions you may notice that the burner does not light quickly, and the flames lift off the burner. If this is situation, we recommend you switch to continuous pilot. This will create a slight draft in the vent, allowing for the burner to light quickly and draft correctly.
- Excessive Condensation on Glass After Startup – certain installations may encounter excessive fogging on the window after startup (not just the first time the stove was started). This is an aesthetic condition that may be remedied by switching the stove to continuous pilot.
- Cold Glass or Stove Front – in very cold conditions you may notice that the stove front and glass become very cold. To remedy this, switch the stove to continuous pilot.
- Frequent On / Off Operation – if you are frequently turning the stove on and off, you may wish to leave it in continuous pilot. This allows the burner to turn on more quickly, without pilot ignition delay.

## Normal Operating Sounds

### Extinction Pops

It is not unusual, especially on Propane (LP) appliances, to experience a "pop" when the burner is shut off.

### Pilot Flame

The pilot flame will make a clicking sound when starting up. When on, it will make a slight whisper sound.

### Gas Control Valve

As the gas control valve is turned on and off you will hear a dull clicking sound. This is the valve opening up and shutting down.

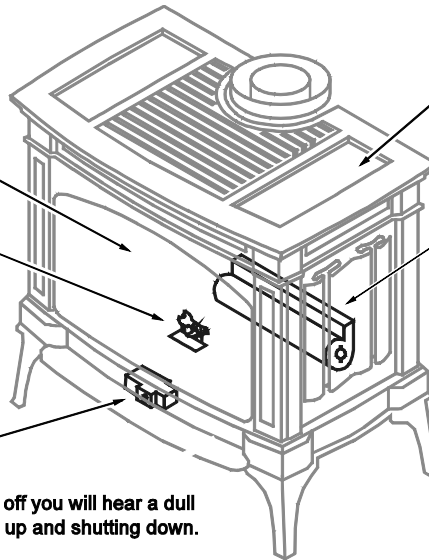

The appliance may creak with change of temperature – THIS IS NORMAL.

### Blowers

This heater has optional blowers to push heated air into the room. You will hear the sound of air movement increase as the speed is of the blower is increased.

## Normal Operating Odors

This appliance has several areas that reach high temperatures. Dust or other particles on these areas may burn and create a burnt-paper smell. This is normal during startup. You may notice the smell is more acute if the appliance was left idle for a long period.

**DANGER HIGH VOLTAGE:** Disconnect power before attempting maintenance or repair.

## Maintaining Your Stove's Appearance

### Painted Surfaces

- Painted surfaces should be cleaned with a duster. If scratches occur, lightly sand the area with fine sandpaper. Clean the area and, with the stove cool, apply one or two thin coats of stove paint to the area (mask the area to avoid overspray). Allow the stove to dry, then turn the stove on to cure the paint (1 hour on medium).

### Enamel Surfaces

- Use only soft cloth and water to clean enamel surfaces. To fix chips in the enamel, follow the directions below:
  - Let the stove cool. Clean the area thoroughly.
  - Shake the Travis Enamel Touch-Up thoroughly. Apply to the damaged area.

### Patina Surfaces

- The patina finish is a "living" color and will age and antique over time. Some portions of the finish may become slightly dull in appearance, especially over the top where it becomes hot. This is normal. The only cleaning we recommend is a light dusting when the appliance is cool.

**DO NOT USE ANY LIQUID, CLEANER, OR ABRASIVES ON THIS FINISH.**

### Front Glass

- Clean the glass with soap and water (do not use abrasive cleaners). Glass removal instructions are on page 25.

## Battery Replacement

### Power Backup Batteries

Four AA batteries are used as a power backup for the stove in case the household (AC) power goes out. They also power the comfort control feature. These batteries must be inserted into battery holder (make sure they contact the terminals - see the illustration below). The fireplace controller will beep once these batteries start to go dead. Replace batteries before each heating season to insure proper operation.

### Control Panel Light Battery

LED lights and a 9v battery are used to illuminate the control panel when the concealment cover is lifted. If the LED lights do not operate, replace the 9v battery (see the illustration below). The battery holder is held in place with Velcro and may be removed for easier access.

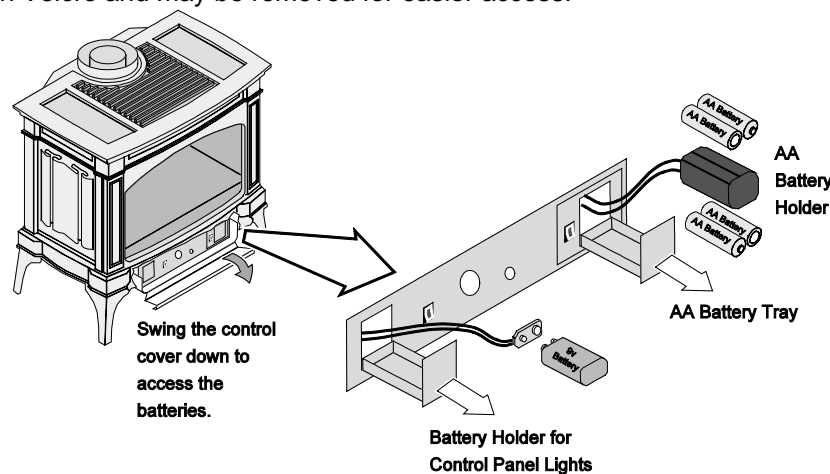

## Accent Light Replacement

An accent light is included in your stove to provide additional lighting. This bulb will burn out over time. To replace, follow the directions below:

- Shut off gas to the stove and let it cool for 15 minutes.
- Remove the glass (see page 25) and logs (see page 27).
- Replace the halogen bulb with the following bulb:  
**NOTE:** Take care to not touch the bulb with your fingers – use foam packing or paper towel to hold the bulb.

35 Watt 120 Volt T4 Halogen Bulb (G6.35 Base)

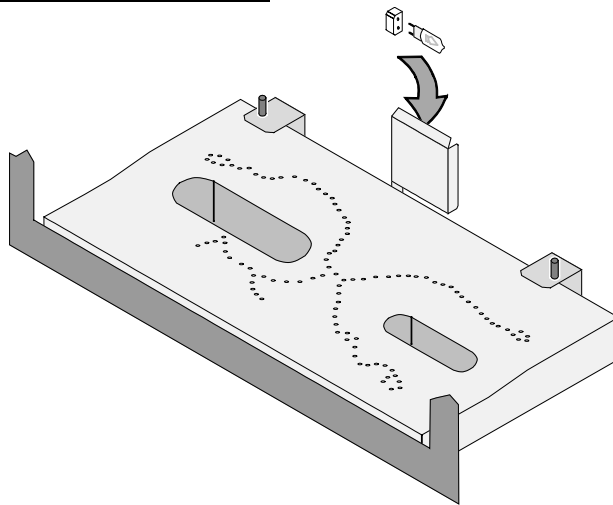

## Yearly Service Procedure

- Failure to inspect and maintain the stove may lead to improper combustion and a potentially dangerous situation. We recommend the following procedures be done by a qualified technician.
1. Turn the pilot flame to continuous. It should touch approximately 3/8" of the top of the flame sensor. If it does not, contact your dealer for service.
  2. Shut off gas to the stove and let it cool for 15 minutes. Remove the glass (see page 25).
  3. Remove the log set (**NOTE: The logs are very fragile** - see page 27). If severely deteriorated, replace. Check the logs for sooting. A small amount of soot along the bottom of the logs is normal. If excessive sooting is found, the stove will require adjustment. Contact your dealer.
  4. Inspect the burner and remove any debris.
    - Make sure the burner is not warped, cracked, or damaged.
    - Check the firebox and area around the pilot to make sure there is no warping or damage.
    - If any problem is found, discontinue use and contact your dealer for service.
  5. Replace the log set. Clean and replace the glass. If the glass is damaged, replace. Make sure the gasket along the perimeter of the glass contacts the face of the firebox and forms an air-tight seal. If it does not, re-align or replace the gasket to insure an air-tight seal.
  6. Inspect the area behind the access door. Clean if necessary. Check the gas control valve and the gas lines. If damage is found, discontinue use and contact your dealer for service. Clean the air channels, ducts, and blower (if applicable).
  7. Start the main burner. After 15 minutes the flames should be orange/yellow and not touch the top of the firebox. If the pilot or main burners do not burn correctly, contact your dealer for service. Monitor blower operation.
  8. Remove any debris or vegetation near the vent termination. Contact your dealer if any sooting or deterioration is found near the vent termination.

## Troubleshooting Table

Problem:	Possible Cause:	Don't Call for Service Until You:
<b>Main Burners Will Not Start</b>	The ON/OFF switch is turned to "OFF" ..... The remote control is not working correctly ..... The thermostat is disconnected or set too low ..... No Propane in Tank.....	Turn the ON/OFF switch to "ON" See the remote control instructions See "Thermostat Operation" Check Tank Level
<b>Heater Beeps</b>	The power backup batteries are dead (heater will beep once repeatedly).....  The heater encountered an error when trying to start (heater beeps 3 times repeatedly) .....  The heater encountered a pilot error (heater beeps 2 times repeatedly) .....	Replace the batteries (see page 37)  Make sure gas is turned on. Turn heater off for 5 seconds (make sure standing pilot is off) – then turn back on.  Contact your dealer if this occurs.
<b>Thermostat Does Not Work</b>	The ON/OFF switch is turned to "OFF" ..... The thermostat is set too low .....	Turn the ON/OFF switch to "ON" Check thermostat
<b>Stove Will Not Distribute Heat</b>	The stove is not getting electricity ..... The stove is not up to temperature.....  The blower fuse may be blown.....	Check the breaker switch Let the stove burn for at least 15 minutes Replace the blower fuse. See fuse location below.
<b>Flames Are Too Blue</b>	The stove has just been started.....  Improper air shutter adjustment.....	This is normal - see "Starting the Stove for the First Time" Adjust Air Shutter - contact your dealer
<b>Flames Are Too Short (Under 6")</b>	The flame height may be turned too low.....	Turn the flame height to "HI" - See "Adjusting the Flame Height"
<b>Comfort Control Does not Work</b>	The AA batteries may be dead.....	Replace the AA batteries (see page 37)
<b>Thin Layer of Soot Covers the Glass</b>	The logs or coals are placed incorrectly..... Improper air shutter adjustment.....	See "Log Set Installation" Adjust Air Shutter - contact your dealer
<b>Accent Light Does Not Work</b>	The bulb may be burned out. .... The accent light fuse may be blown.....	See "Accent Light Replacement" on page 38 Replace the fuse. See fuse location below.

Location of fuses (3 amp):

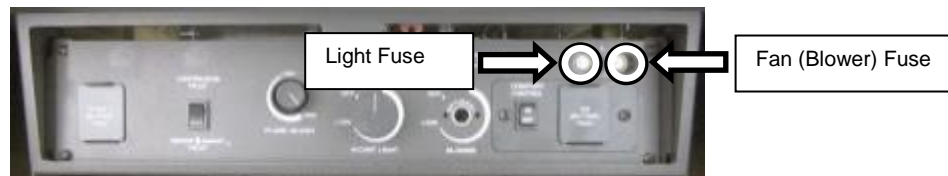

## Replacement Parts List

**Caution:** Use only Travis Industries replacement parts. Do not use substitute materials.

**Warning:** Do not operate appliance with the glass front removed, cracked, or broken. Replacement of the glass should be done by a licensed or qualified service person.



Contact your local Travis Industries Dealer for a Replacement Parts List

## Safety Label

The safety (listing) label is on the back of the stove. A copy is shown below.



Report No. 10142329PFT-001  
Control No. 4000515

Tested to: ANSI Z21.68-2014/CSA 2.33-2014 "Vented Gas Fireplace Heater", CGA 2.17-081 (R2008) "Gas Burning Heating Appliances for Manufactured Homes", and CSA P.A.1-09 Testing method for measuring annual fireplace efficiency.

This appliance must be installed in accordance with local codes, if any; if none, follow the National Fuel Gas Code, ANSI Z223.1/NFPA 54, or Natural Gas and Propane Installation Codes, CSA B149.1.

This appliance must be installed in accordance with the current Standard CAN/CSA Z240 MH, Mobile Housing, in Canada or with the Manufactured Home Construction and Safety Standard, Title 24 CFR, Part 3280, in the United States, or when such a standard is not applicable, ANSI/NCSSBCS A225-1/NFPA 501A, Manufactured Home Installation Standard.

This vented gas fireplace heater is equipped at the factory for use with natural gas. If conversion to propane (LP) is desired, the optional factory conversion kit must be used. Part No. 250-01427 register kit may be used.

This appliance is only for use with the type of gas indicated on the rating plate and may be installed in an attic, permanently located, manufactured home (USA only) or mobile home, where not prohibited by local codes. See owner's manual for details. This appliance is not convertible for use with other gases, unless a certified kit is used.

This vented gas fireplace heater is not for use with air filters.

Keep burner and control compartment clean. See installation and operating instructions accompanying appliance.

This appliance must be properly connected to a venting system in accordance with the manufacturer's installation instructions. Use only approved coaxial direct vent system to vent this appliance to the exterior. See owner's manual for approved brands of venting.

If the vent-air intake system is disconnected for servicing or any other reason, it must be resealed and / or reinstalled.

WARNING: Improper installation, adjustment, alteration, service or maintenance can cause injury or property damage. Refer to the owner's information manual provided with this appliance. For assistance or additional information consult a qualified installer, service agency or the gas supplier.

**Minimum Clearances to Combustibles**

Stove Top to Sidelwall	10" (254mm)	Alcove Minimum Height	58" (1473mm)
Stove Top to Backwall	5" (127mm)	Alcove Maximum Height	45" (1143mm)
Stove Top to Cornerwall	5" (127mm)	Alcove Minimum Width	46.75" (1187mm)
Glass Front of Unit	3 3/8" (914mm)		

**FAN TYPE VENTED CIRCULATOR**

Blower Electrical Rating: 115V, 60 Hz, 1.5 Amps. Part No. 9690159 fan or blower assembly may be used  
DANGER! Risk of Electric Shock. Disconnect power before servicing unit.

	L.P.	N.G.	L.P.	N.G.
Input Rate on "HP" (BTU/HR)	31,000	31,000	11"	5.5"
Input Rate on "LP" (BTU/HR)	12,600	10,700	13"	7"
Orifice Size - Front (DMS)	#58	#50	11"	3.5"
Orifice Size - Rear (DMS)	#66	#47		

Minimum Inlet Pressure (Inches W.C.)  
Maximum Inlet Pressure (Inches W.C.)  
Manifold Pressure on "HP" (Inches W.C.)

This appliance is equipped for use only at altitudes 0-2,000 feet (0-610m) in the USA. In Canada, 0-4,500 feet (0-1370m). For altitudes above 2,000 feet, the vent configuration, orifice, or combination of both may need to be changed. See owner's manual for information on making these changes.

Manufactured by:  
  
TRAVIS INDUSTRIES  
HOUSE OF FIRE  
www.travisproducts.com

**WARNING:** Failure to install this appliance per the manufacturer's instructions or failure to use only parts specifically approved with this appliance may result in property damage or personal injury.

**CAUTION:** Do not operate this appliance with glass removed, cracked or broken. Replacement of the pane(s) should be done by a licensed or qualified service person.



# Warranty

41

Register your TRAVIS INDUSTRIES, INC. Limited 7 Year Warranty online at [traviswarranty.com](http://traviswarranty.com), or complete the enclosed Warranty card and mail it within **ten (10)** days of the appliance purchase date to: TRAVIS INDUSTRIES, INC., 12521 Harbour Reach Drive, Mukilteo, WA 98275. TRAVIS INDUSTRIES, INC. warrants this gas appliance (appliance is defined as the equipment manufactured by Travis Industries, Inc.) to be defect-free in material and workmanship to the original purchaser from the date of purchase as follows:

Check with your dealer in advance for any costs to you when arranging a warranty call. Mileage or service charges are not covered by this warranty. This charge can vary from store to store.

<u>Component</u>	Years 1 & 2 Parts & Labor	Years 3 Through 5 Parts & Labor	Years 6 & 7 Parts Only
<u>Burner Assembly</u> Burner Pan Assembly, Air Shutter Assembly, Main Burner Orifice	✓		
<u>Electrical Assembly (within heater structure):</u> Wiring harness, snap discs, rheostat speed control	✓		
<u>Gas Control Assembly</u> Adjustable control valve, fireplace controller, pilot assembly and pilot wiring	✓		
<u>Glass</u> Glass (breakage from thermal shock)	✓		
<u>Ceramic Logs</u> Log Set, Embers	✓		
<u>Gold, Nickel &amp; Copper Plating</u> Face & Door (see "Conditions and Exclusions" # 9)	✓		
<u>Enamel Finish</u> Warranted against peeling or fading, excluding chipping, mechanical abrasion, or crazing.	✓		
<u>Accessories</u> Firebacks, Power Heat Ducts, Andirons, etc...	✓		
<u>One-Way Freight Allowance</u> One-way freight allowance on pre-authorized repair done at factory is covered.	✓	✓	
<u>Convection Heat Exchanger</u> Convection heat exchanger assembly	✓	✓	
<u>Firebox Assembly</u> Adjustable Air Restrictor, Pressure Relief Mechanisms, Glass Attachment Mechanism	✓	✓	✓

### EXCLUDED COMPONENTS:

Paint, Gasketing, and Accent Light Bulbs

### **CONDITIONS & EXCLUSIONS**

- This new gas appliance must be installed by a qualified gas appliance technician. It must be installed, operated, and maintained at all times in accordance with the instructions in the Owner's Manual. Any alteration, willful abuse, accident, neglect, or misuse of the product shall nullify this warranty.
- This warranty is nontransferable, and is made to the ORIGINAL purchaser, provided that the purchase was made through an authorized TRAVIS dealer.
- Discoloration and some minor expansion, contraction, or movement of certain parts and resulting noise, is normal and not a defect and, therefore, not covered under warranty. The installer must ensure the appliance is burning as per the rating tag at the time of installation. Over-firing (operation above the listed BTU rate) of this appliance can cause serious damage and will nullify this warranty.
- The warranty, as outlined within this document, does not apply to the chimney components or other Non-Travis accessories used in conjunction with the installation of this product. If in doubt as to the extent of this warranty, contact your authorized TRAVIS retailer before installation.
- Travis Industries will not be responsible for inadequate performance caused by environmental conditions such as nearby trees, buildings, roof tops, wind, hills or mountains or negative pressure or other influences from mechanical systems such as furnaces, fans, clothes dryers, etc.
- This Warranty is void if:
  - The unit has been operated in atmospheres contaminated by chlorine, fluorine or other damaging chemicals.
  - The unit is subject to submersion in water or prolonged periods of dampness or condensation.
  - Any damage to the unit, combustion chamber, heat exchanger or other components due to water, or weather damage which is the result of, but not limited to, improper chimney/venting installation.
- Exclusions to this 7 Year Warranty include: injury, loss of use, damage, failure to function due to accident, negligence, misuse, improper installation, alteration or adjustment of the manufacturer's settings of components, lack of proper and regular maintenance, damage incurred while the appliance is in transit, alteration, or act of God.
- This 7 Year warranty excludes damage caused by normal wear and tear, such as paint discoloration or chipping, worn or torn gasketing, corroded or cracked logs, embers, etc. Also excluded is damage to the unit caused by abuse, improper installation, modification of the unit, drilling of the orifices, or the use of fuel other than that for which the unit is configured. Units are shipped for natural gas and must be converted to propane using the included conversion kit. Confirm fuel configuration with your installer.
- Damage to gold or nickel surfaces caused by fingerprints, scratches, melted items-, or other external sources left on the gold or nickel from the use of cleaners other than denatured alcohol is not covered in this warranty.
- TRAVIS INDUSTRIES, INC. is free of liability for any damages caused by the appliance, as well as inconvenience expenses and materials. Incidental or consequential damages are not covered by this warranty. In some states, the exclusion of incidental or consequential damage may not apply.
- This warranty does not cover any loss or damage incurred by the use or removal of any component or apparatus to or from the gas appliance without the express written permission of TRAVIS INDUSTRIES, INC. and bearing a TRAVIS INDUSTRIES, INC. label of approval.
- Any statement or representation of TRAVIS products and their performance contained in TRAVIS advertising, packaging literature, or printed material is not part of this 7 year warranty.
- This warranty is automatically voided if the appliance's serial number has been removed or altered in any way. If the appliance is used for commercial purposes, it is excluded from this warranty.
- No dealer, distributor, or similar person has the authority to represent or warrant TRAVIS products beyond the terms contained within this warranty. TRAVIS INDUSTRIES, INC. assumes no liability for such warranties or representations.
- Travis Industries will not cover the cost of the removal or re-installation of hearths, facing, mantels, venting or other components.
- If for any reason any section of this warranty is declared invalid, the balance of the warranty remains in effect and all other clauses shall remain in effect.
- THIS 7 YEAR WARRANTY IS THE ONLY WARRANTY SUPPLIED BY TRAVIS INDUSTRIES, INC., THE MANUFACTURER OF THE APPLIANCE. ALL OTHER WARRANTIES, WHETHER EXPRESS OR IMPLIED, ARE HEREBY EXPRESSLY DISCLAIMED AND PURCHASER'S RECOURSE IS EXPRESSLY LIMITED TO THE WARRANTIES SET FORTH HEREIN.**

### **IF WARRANTY SERVICE IS NEEDED:**

- If you discover a problem that you believe is covered by this warranty, you MUST REPORT it to your TRAVIS dealer WITHIN 30 DAYS, giving them proof of purchase, the purchase date, and the model name and serial number.
- Travis Industries has the option of either repairing or replacing the defective component.
- If your dealer is unable to repair your appliance's defect, he may process a warranty claim through TRAVIS INDUSTRIES, INC., including the name of the dealership where you purchased the appliance, a copy of your receipt showing the date of the appliance's purchase, and the serial number on your appliance. At that time, you may be asked to ship your appliance, freight charges prepaid, to TRAVIS INDUSTRIES, INC. TRAVIS INDUSTRIES, INC., at its option, will repair or replace, free of charge, your TRAVIS appliance if it is found to be defective in material or workmanship within the time frame stated within this 7 year warranty. TRAVIS INDUSTRIES, INC. will return your appliance, freight charges (years 1 to 5) prepaid by TRAVIS INDUSTRIES, INC., to your regional distributor, or dealership.
- Check with your dealer in advance for any costs to you when arranging a warranty call. Mileage or service charges are not covered by this warranty. This charge can vary from store to store.

## LP Conversion Instructions

### **WARNING**

This conversion kit shall be installed by a qualified service agency in accordance with the manufacturer's instructions and all applicable codes and requirements of the authority having jurisdiction. If the information in these instructions is not followed exactly, a fire, explosion or production of carbon monoxide may result causing property damage, personal injury or loss of life. The qualified service agency is responsible for the proper installation of this kit. The installation is not proper and complete until the operation of the converted appliance is checked as specified in the manufacturer's instructions supplied with the kit.

### **CAUTION:**

The gas supply shall be shut off prior to disconnecting the electrical power, before proceeding with the conversion.

### **IMPORTANT:**

A converted appliance must have a label attached marked with the following:

"This appliance was converted to \_\_\_\_ gas with Kit No. \_\_\_\_ by \_\_\_\_ (name and address of organization making the conversion), which accepts the responsibility that this conversion has been properly made. This control has been converted for use with gas \_\_\_\_."

### **Install the conversion kit prior to installing the gas line to ensure proper gas use.**

- 1 Remove the glass (see page 25). Remove the logs and embers (if installed - page 27).
- 2 Remove the burner (see below). Grasp the burner with both hands and lift it straight up and out of the firebox.

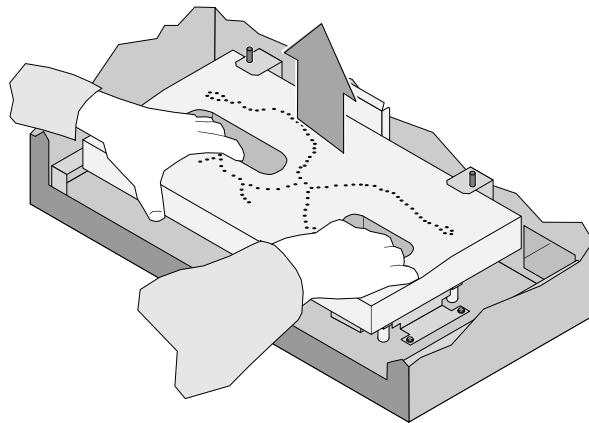

- 3 Remove the manifold cover to access the burner orifices (see below). Replace the manifold cover after the LP burner orifices are installed.

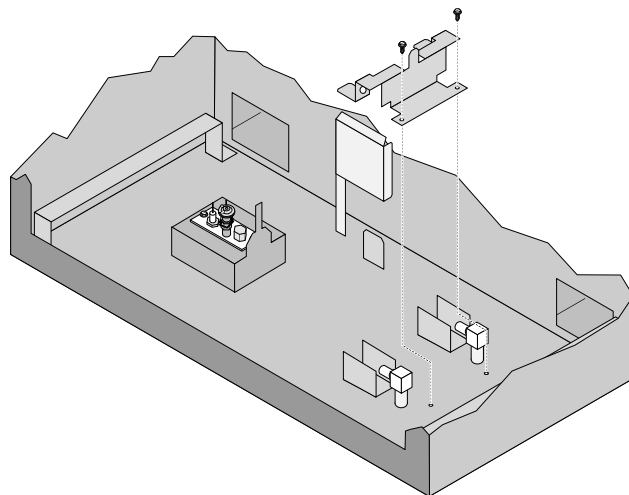

4 Follow the directions below to replace the orifices.

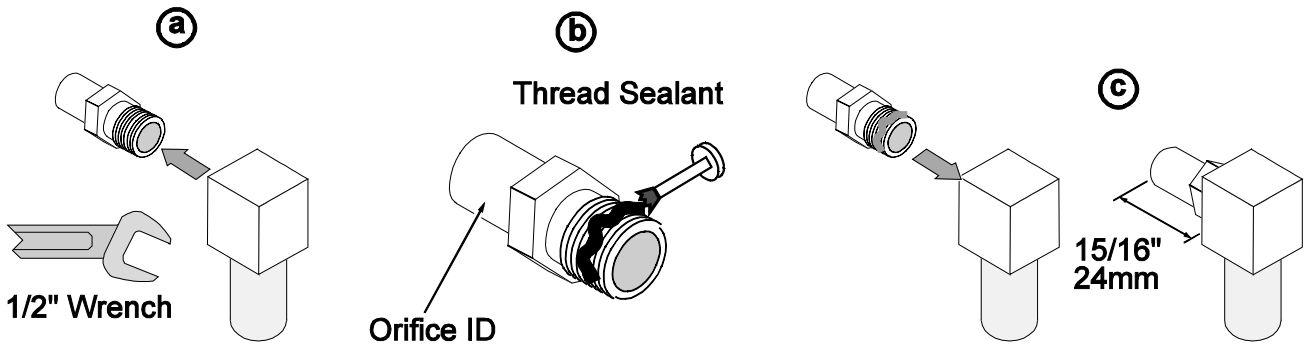
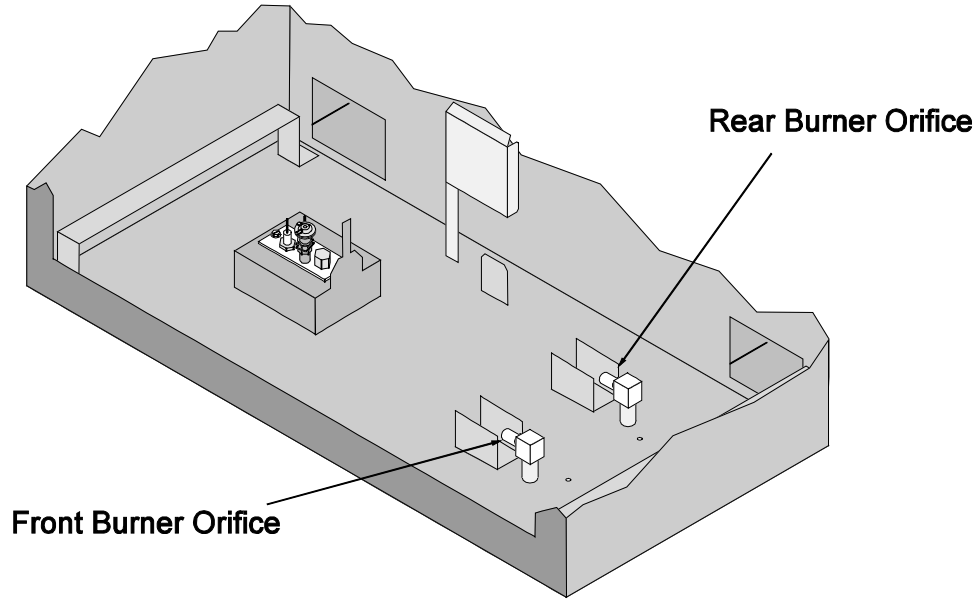

<b>ORIFICE SIZE</b>	<b>Natural Gas</b>	<b>LP (Propane)</b>
Front Burner Orifice	#50 DMS	#58 DMS
Rear Burner Orifice	#47 DMS	#56 DMS

- 5 Remove and discard the NG air deflector. Attach the LP air deflector included with the stove. Note how the LP deflector has a notch along the bottom.

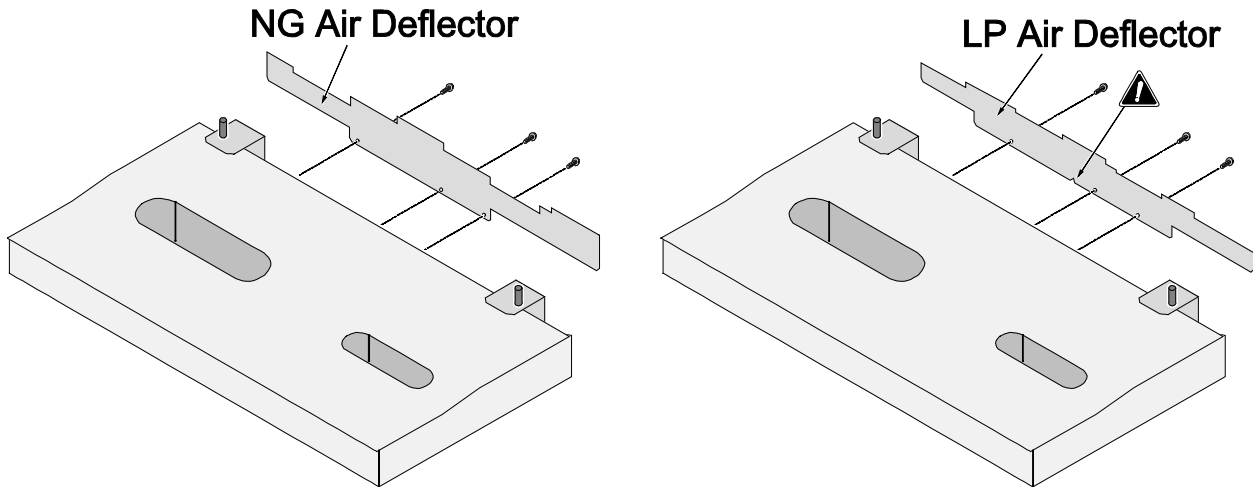

- 6 Install the LP pilot orifice following the directions below.

- (a) Use a 7/16" open-end wrench to remove the pilot hood.
- (b) Remove and discard the Natural Gas (NG) orifice. Place the LP orifice in the pilot assembly then replace the pilot hood, tightening the pilot hood until it is snug (do not over-tighten).

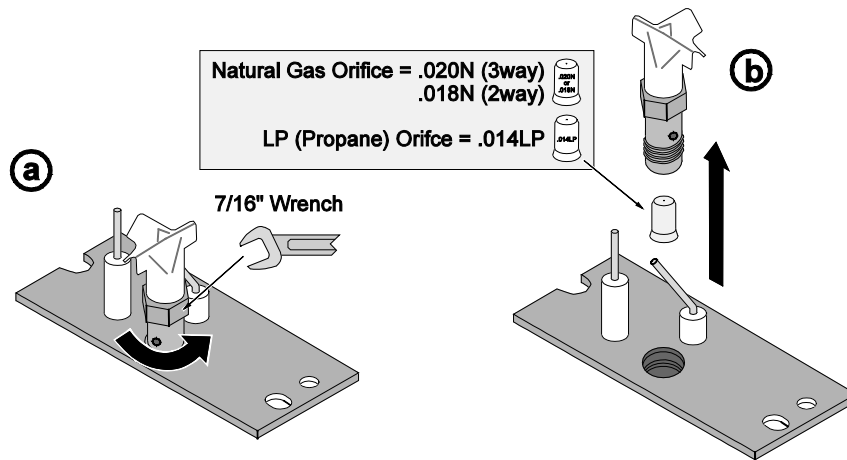

- 7 Replace the firebox components. Install the logs and embers. Replace the glass.

- 8 Remove and discard the screws (see “a” below) holding the stock regulator in place (see “b” below). Remove the stock regulator and gasket (see “c” below). Place the LP regulator in place, making sure the pre-fitted gasket (see “c” below) is in place.

NOTE: There is a label on the base of the regulator knob indicating regulator type (NG or LP). Secure the regulator with the screws included with the regulator – tighten to 25 lb-in of torque. Place the included label on the valve body where it can be easily seen to insure proper identification.

**NOTE: Leak test this area after the heater is installed, gas is connected, and the main burner is lit.**

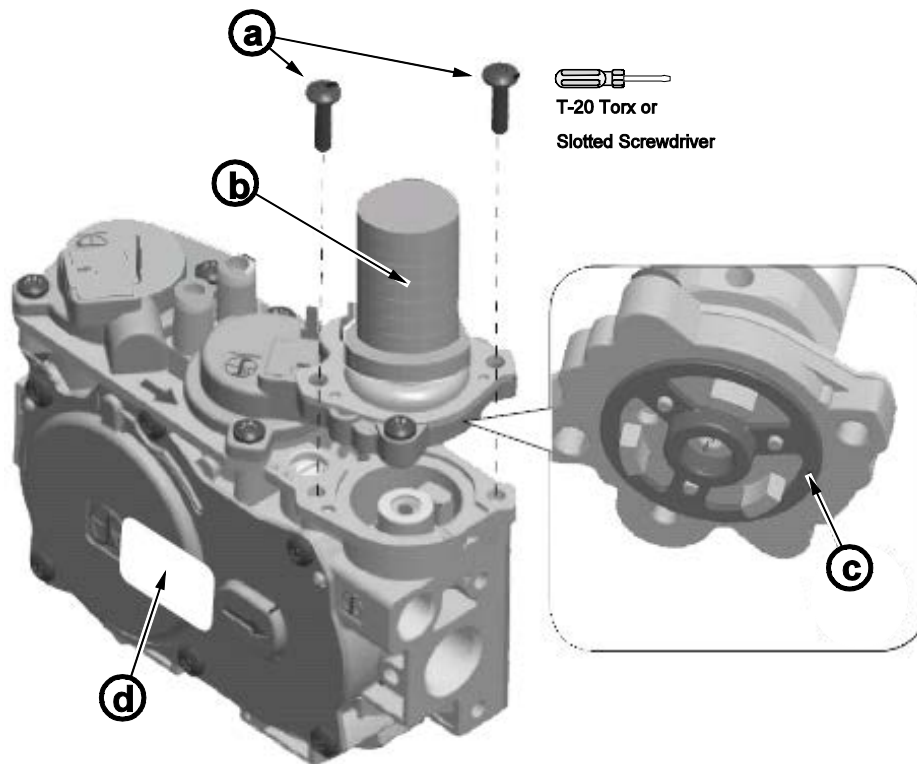

- 9 Make the gas line connection, bleed the gas line (if applicable), start the heater and thoroughly leak-test all gas connections and the gas control valve.

## GS2 Remote Installation

### Packing List

- Transmitter
- Battery Box
- Remote Wall Mount with Attachment Screws and Anchors
- Stepper Motor
- Torx Wrench
- Remote Control DVD
- GSR2 IFC
- Split-flow Harness (attached to IFC)
- System Jumper (attached to IFC)
- Battery Box Harness (attached to IFC)
- Fan/Light Harness (attached to IFC)
- (2) Jumper Wires
- (2) 4" Cable Ties

### Warnings



Turn off power to the heater (unplug or turn off at the breaker).



Shut off gas at the appliance (or at meter).

#### **HINT:**

If using a blower, make sure to have it on hand while installing the remote.

### Remote Control / Pilot Warnings



**Installing batteries in the battery holder or connecting the appliance to power may automatically initiate the CPI pilot mode, resulting in a lit pilot flame. Do not place combustibles in the firebox.**

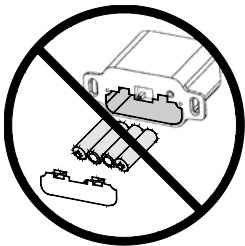

## KEEP BATTERIES AND COVER INSTALLED AT ALL TIMES

The remote control system requires the batteries and battery cover to remain in place at all times. Once the batteries or cover are removed, the system may restart in standing pilot mode. If this occurs when the heater is in Remote Mode, you will not be able to turn the heater off manually from the battery box.

If you need to replace dead batteries, make sure to **turn the appliance off** before removing the batteries.

**NOTE:** If the batteries go dead, the system will operate normally as long as household power (120v AC) is present.

## Base Wiring Diagram

**Caution:** Label all wires prior to disconnection when servicing controls. Wiring errors can cause improper and dangerous operation.

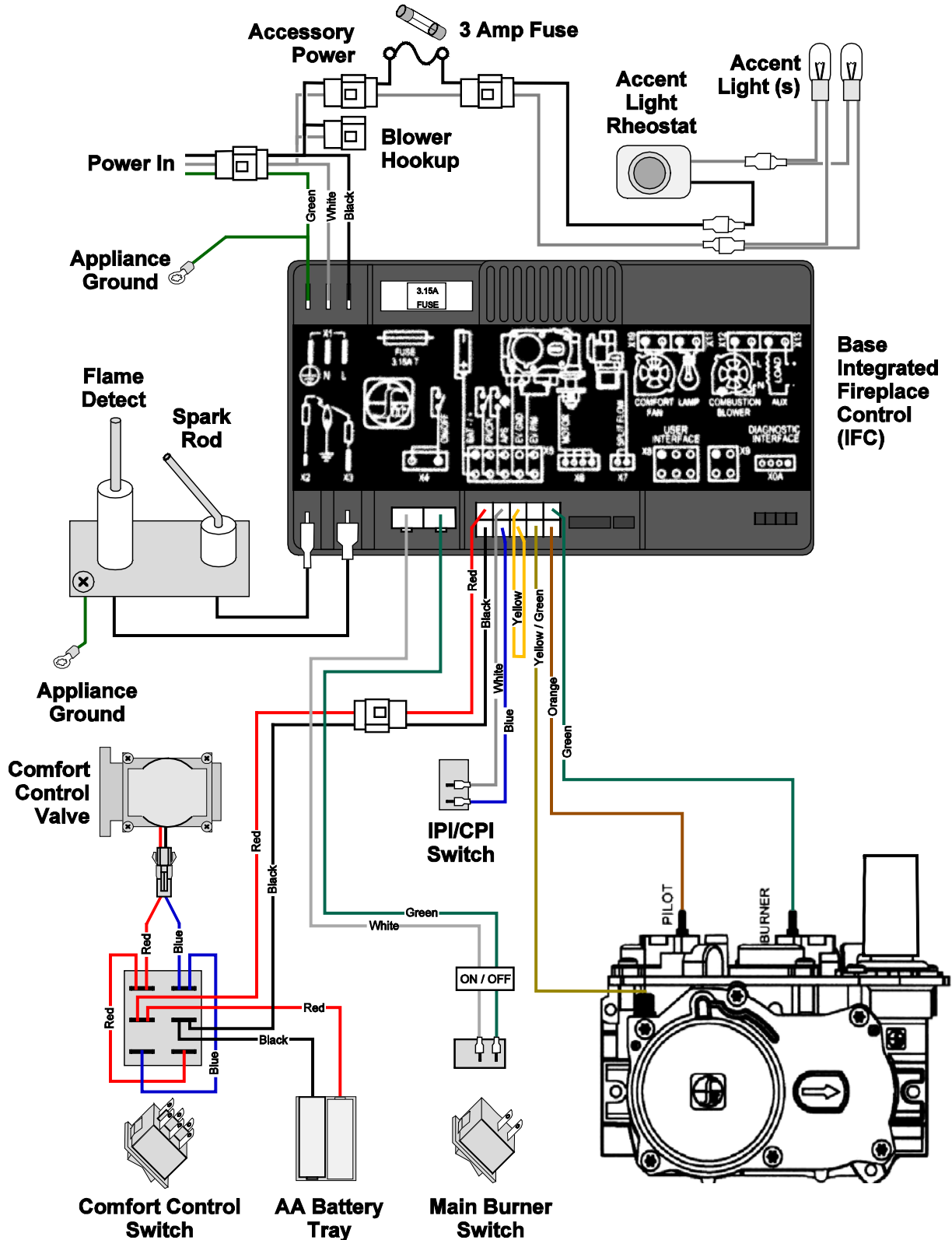

## GS2 Remote Wiring Diagram

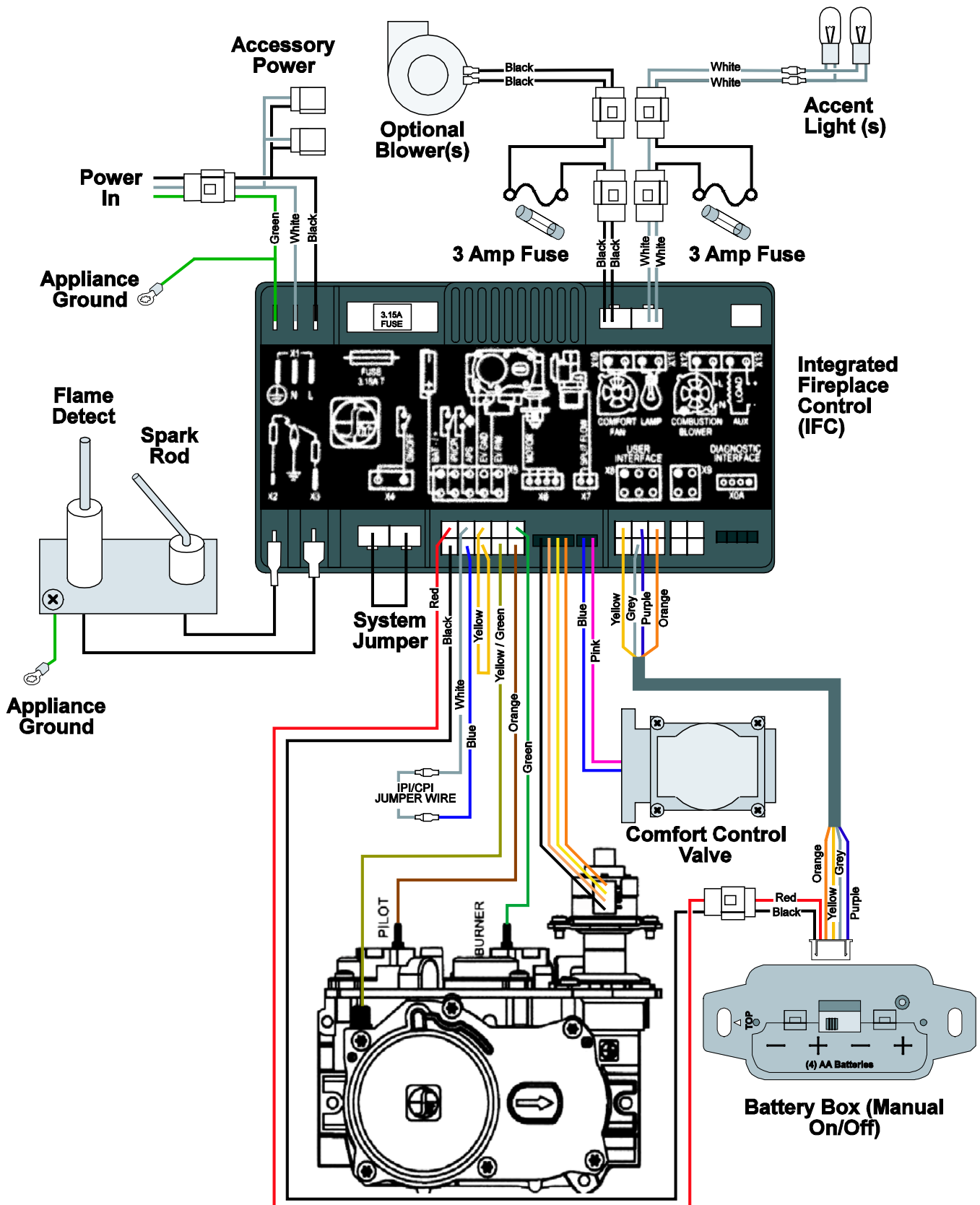



## Installation

1. Remove the Comfort Control–Battery Plate from the control panel (keep the screws).



2. Disconnect the comfort control and battery backup wires. The Comfort Control–Battery Plate may be discarded or kept for spare parts.



3. The component tray may be disconnected and dropped to access the internal components. Loosen the 4 thumb-screws on the sides of the tray, slide it forward, and let it rest under the stove.

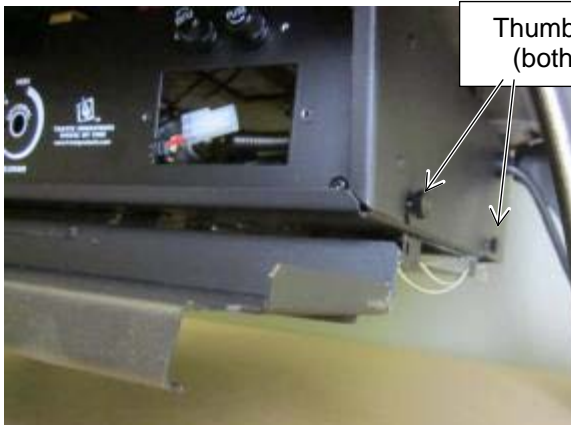

Thumb Screws  
(both sides)



4. Remove the control panel and place face-down in front of the heater (keep the 4 screws).

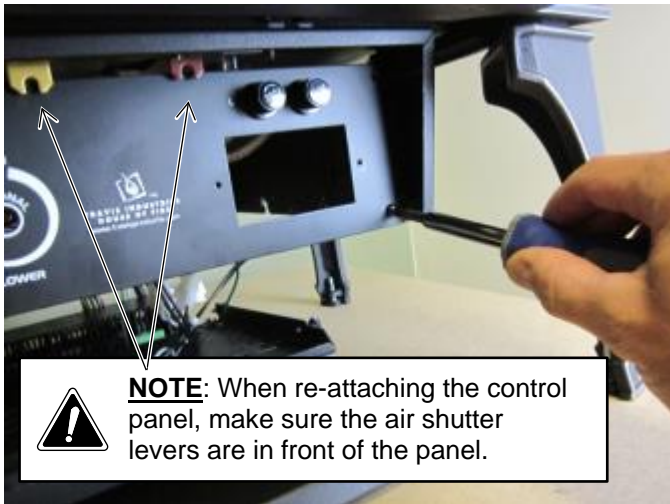

5. The internal components of the stove may now be accessed.



6. Disconnect the input power near the power cord.

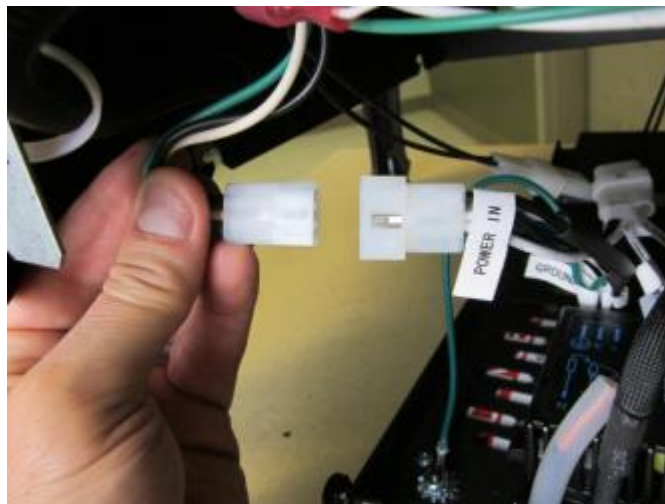

7. Disconnect the following:

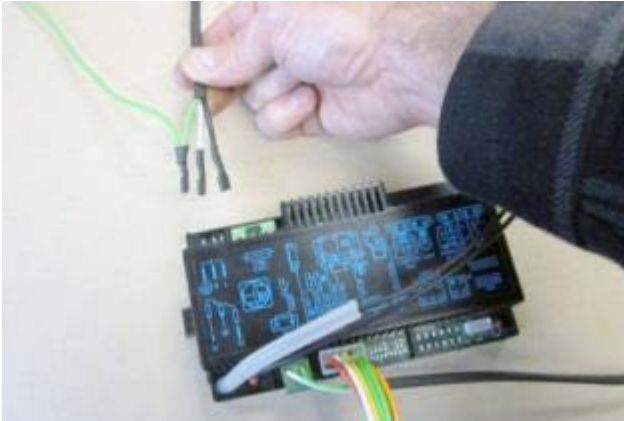

Power (3 wires)

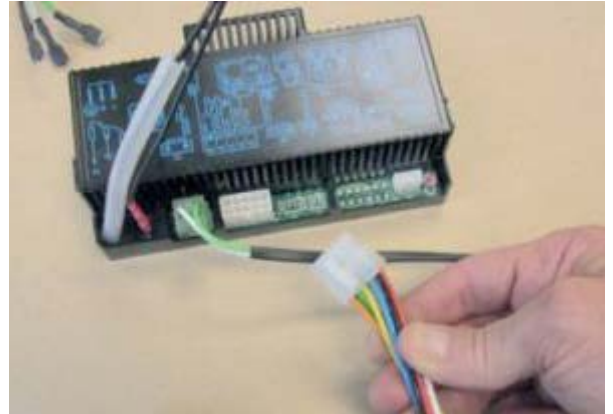

Main harness



On/Off wires

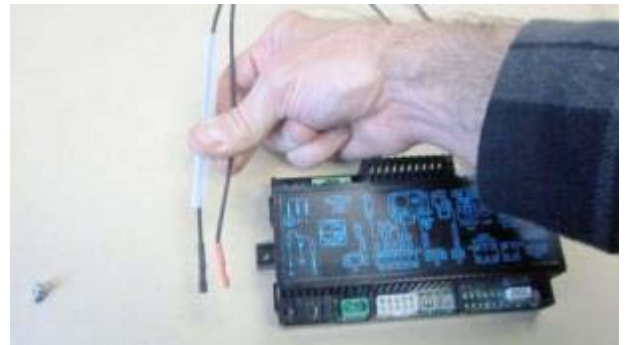

Pilot connections (slide silicone tubing up)

8. Remove and place aside the base IFC (it may be kept for spare parts).  
9. Remove the on/off switch by prying it out. Disconnect the wires.

10. Push the wires back into the holder to conceal them.



11. Remove and discard the screws (see “a” below) holding the stock regulator in place (see “b” below). Remove and discard the stock regulator, spring, and gasket (see “c” below).

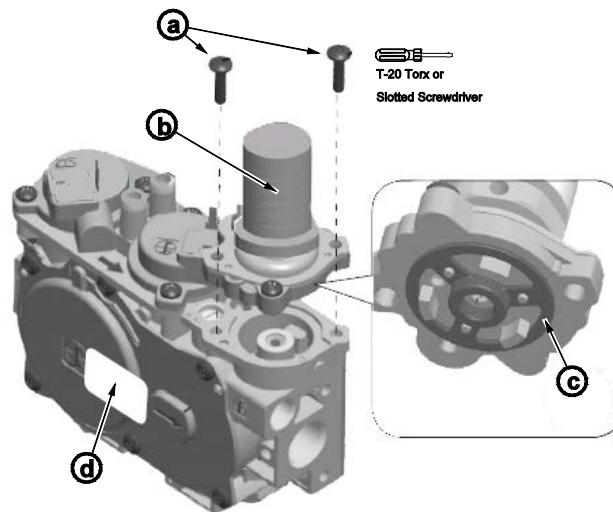

12. The stepper motor (adjustable regulator) has an installation sheet included with it – make sure to follow all of the directions. Place the stepper motor on the gas control valve (see below) – **MAKE SURE IT IS CORRECTLY ORIENTED.** Secure using the screws included with the motor – tighten to 25 Lb-inches. Leak-test this area after installation to verify proper installation. Route the stepper motor wire near the IFC location.

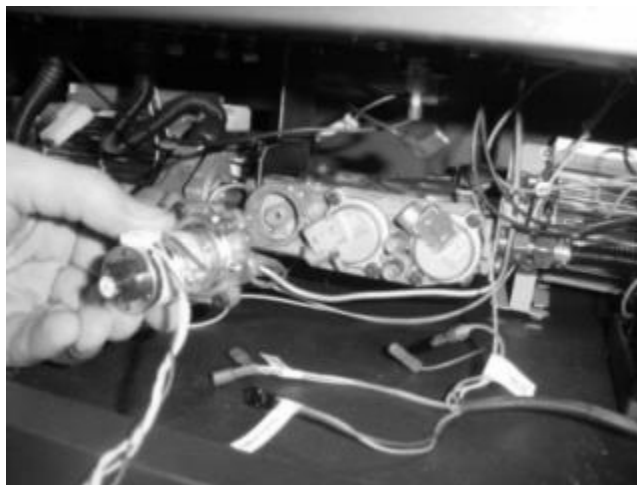

## **Instructions for Using the Optional Blower with GS2 Remote**

When using the GreenSmart™ 2 remote, the power for the blower will be routed through the fuse and IFC, bypassing the rheostat and snap disc included with the blower kit.

### **Order of Installation**

Install the blower assemblies with the IFC removed (see instructions included with the blower for details). Connect the wiring as shown below, attaching the power input to the IFC after the IFC is placed in location (see “e” below).

### **Wiring the Blower to the GSR2 IFC (Bypassing the Rheostat and Snap Disc)**

Disconnect the blower power input (see “a” below). Connect the blower wiring harness to the fuse output (see “b” below). Disconnect and discard the electrical line intended to connect the snap disk to the rheostat (carefully remove the wire tie from the wiring harness – see “c”). Attach the jumper wire (included with the remote) to the wires labeled “SNAP DISC” (see “d” below). Attach the blower power input (see “e”) to “FAN” lead on the fuse harness (pre-connected to the IFC). This circuit bypasses the rheostat and snap disc (these components included with the blower kit are not used and may be kept for replacement part purposes).

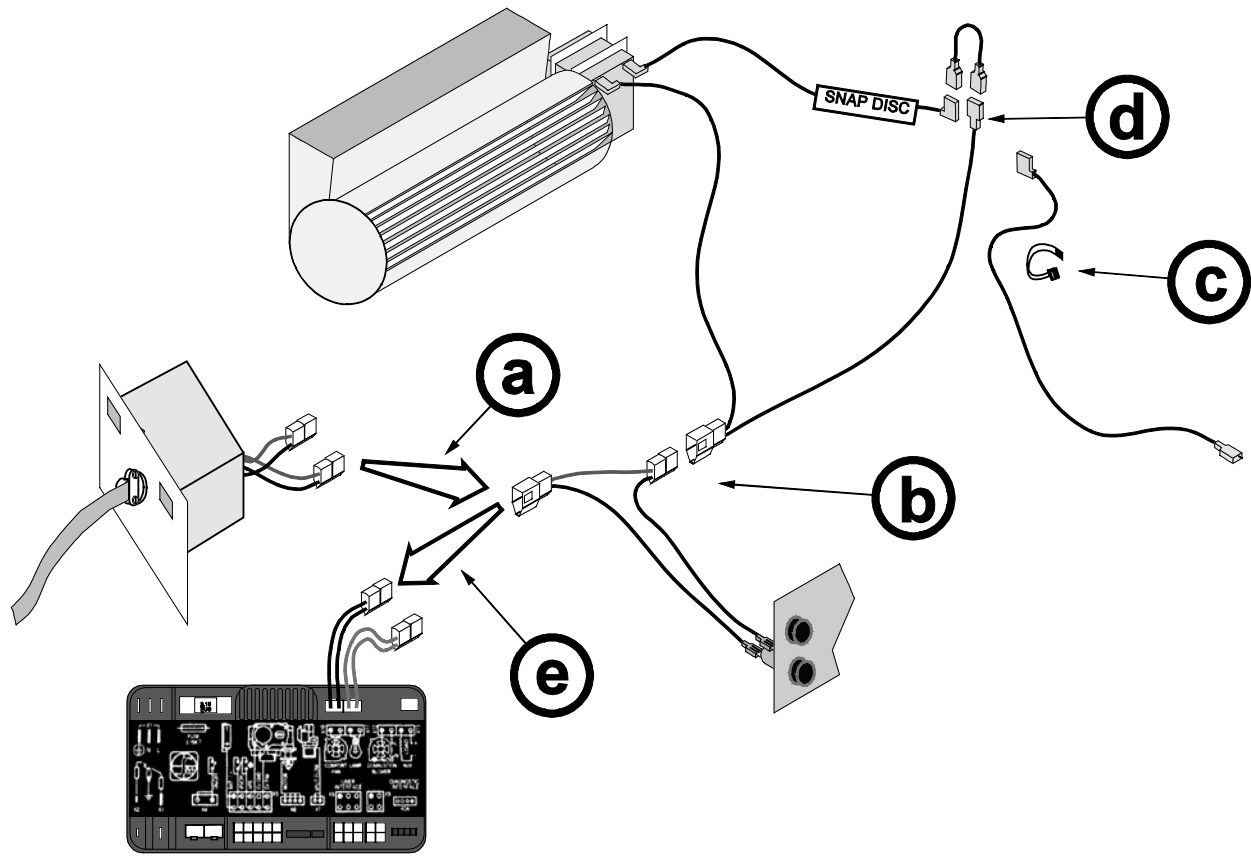

## 13. Wire the accent light for remote operation.

When using the GreenSmart™ 2 remote, the power for the accent light(s) will be routed through the fuse and IFC, bypassing the rheostat.

### Order of Installation

Connect the wiring with the IFC removed as shown below. Attach the power input to the IFC after the IFC is placed in location (see “a” below).

### Wiring the Blower to the GSR2 IFC (Bypassing the Rheostat)

Disconnect the accent light power input (see “a” below). Disconnect the two wires leading to the rheostat and attach them together (see “b” below). Remove the rheostat from the control panel (see “c” below). Attach the accent light power input (see “d”) to “LIGHT” lead on the fuse harness (pre-connected to the IFC). This circuit bypasses the rheostat (this component is not used and may be kept for replacement part purposes).

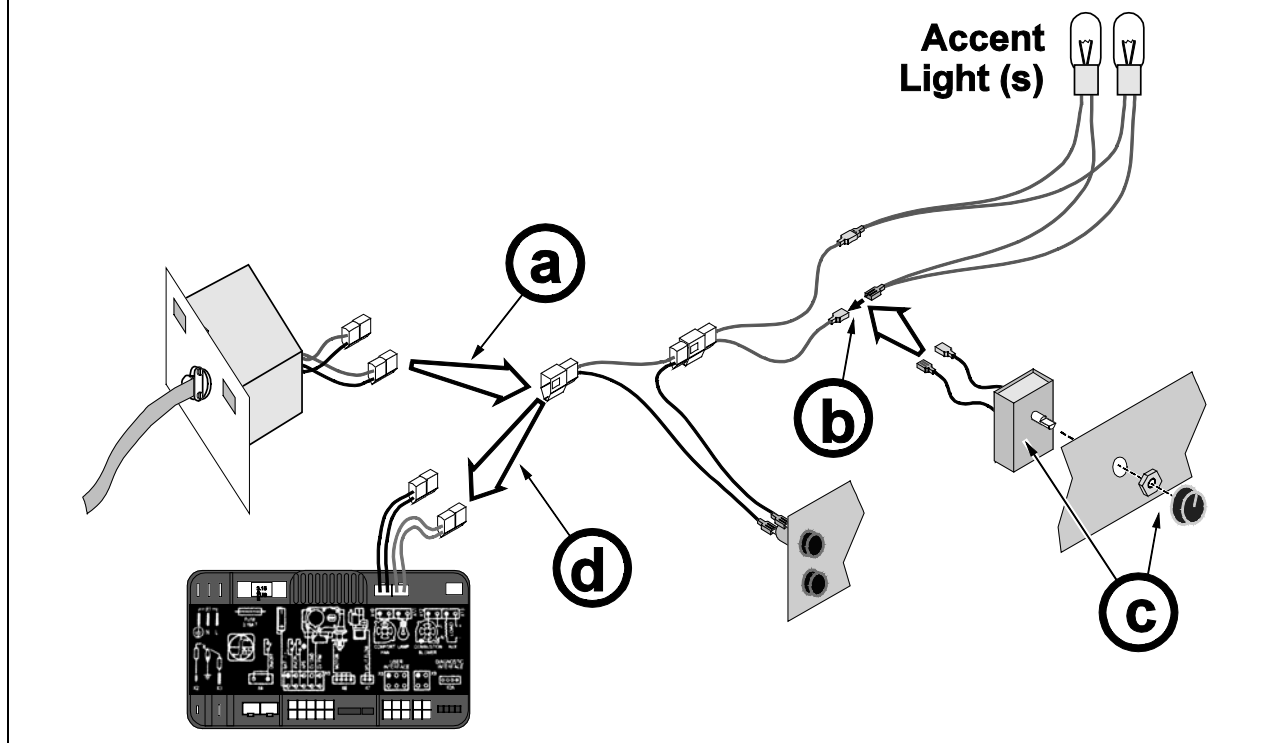

## 14. Place the GSR2 IFC near the appliance.

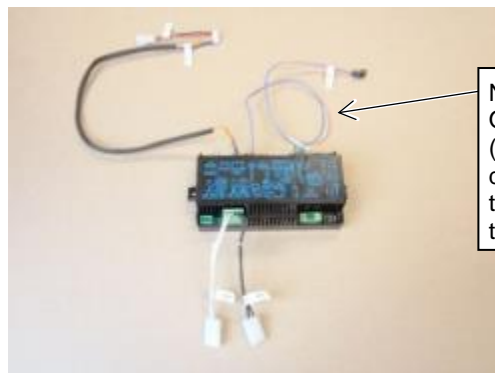

**NOTE:**  
On newer units the comfort control (splitflow) jumper is removed and discarded. It is not needed because the splitflow wire connects directly to the IFC.

15. Attach the following:

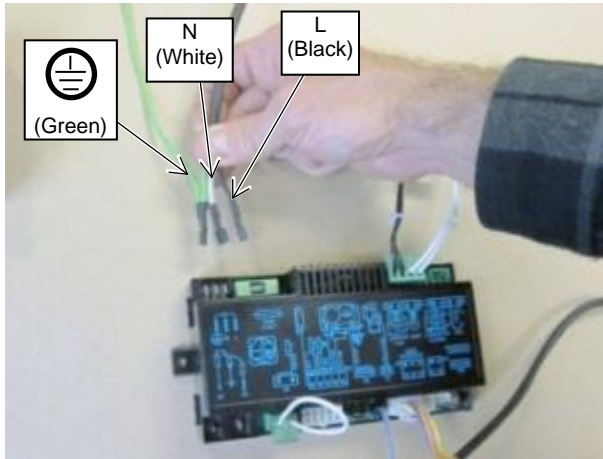

Power (3 wires – make sure orientation is correct)

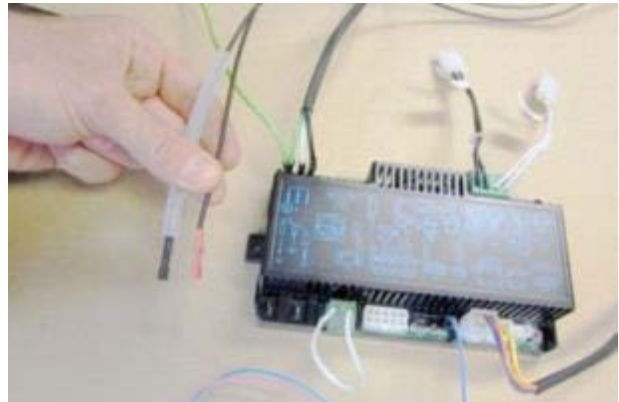

Pilot connections

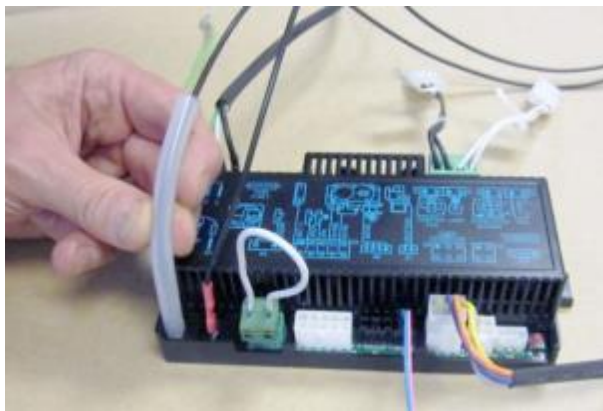

Make sure silicone tubing is pushed down

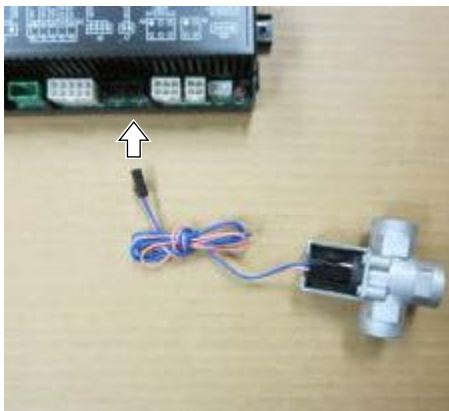

Comfort Control connection

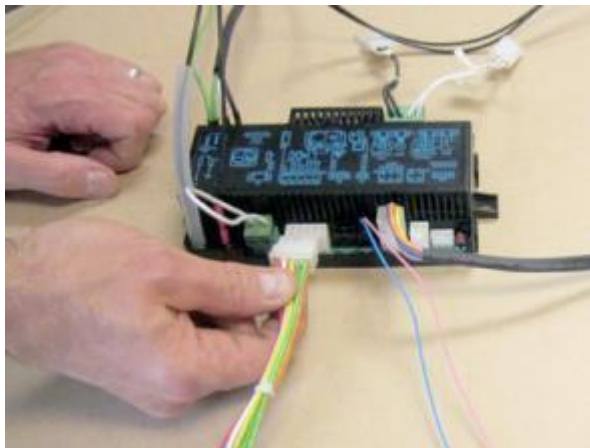

Main Harness

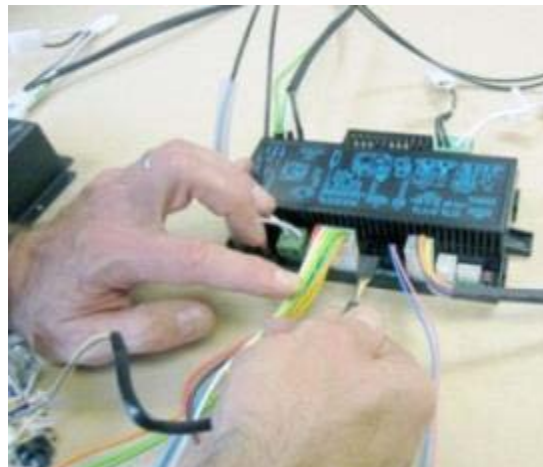

Stepper Motor

16. Disconnect the IPI/CP switch from IPI/CP wires. Attach one of the jumper wires to the two wires. Discard the IPI/CP switch.

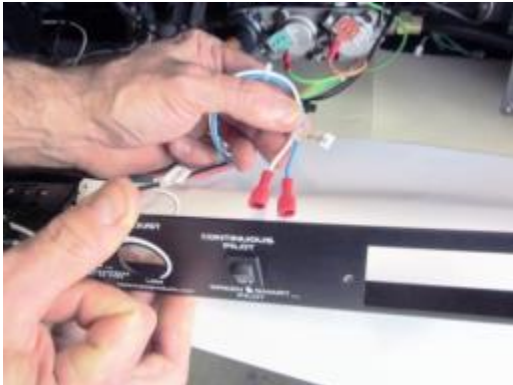

17. Remove the IPI/CPI switch and place aside (may be kept for spare parts).



18. Connect the accent light wires to the GSR2 IFC.



NOTE: If using a blower, connect the power input to the GSR2 IFC.



19. Connect the battery box power molex connector to the main harness molex connector.

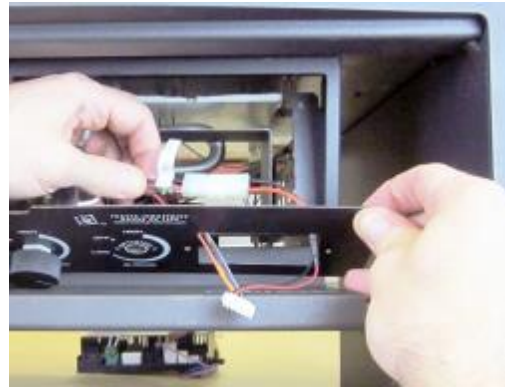
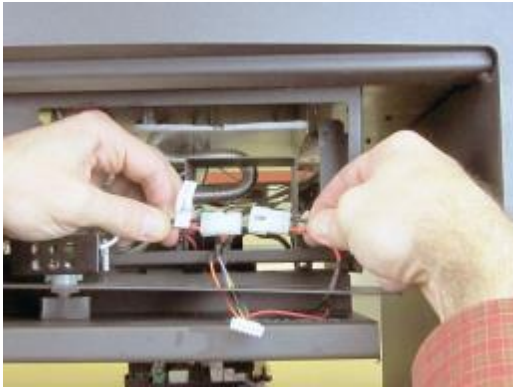

20. Route the battery box harness through the control panel and attach to the battery box.



21. Place the IFC on the component tray using the supplied velcro tape.
22. Use the two included cable ties to make sure all wiring is secure and does not contact any hot or moving parts.
23. The component tray may be re-attached at this time.

24. Re-attach the control panel.



25. Attach the battery box to the control panel using the screws removed earlier.



26. Re-connect the input power.

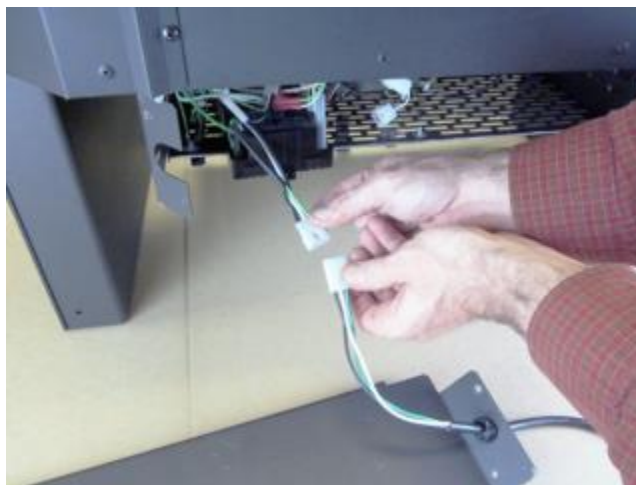

27. Replace the rear panel and restore the stove to the correct configuration (turn on power and gas).

**See the instructions included with the remote for synchronizing the remote and the operating instructions.**

**Index**

Accent Light .....	35	Installation Hints.....	8
Accent Light Replacement .....	38	Installation Overview.....	7
Additional Accessories Required .....	7	Installation Warnings .....	7
Additional Items Required .....	7	Interior Masonry Chimney Conversions .....	22
Adjusting the Flame Height.....	34	Introduction .....	2
Adjusting the Optional Blower Speed .....	35	Listing Details.....	2
Approved Vent Configurations .....	13	Location of Controls.....	33
Battery Replacement.....	37	Log Installation.....	27
Before You Begin .....	33	LP Conversion Instructions.....	42
Class A Chimney Conversion Kit .....	21	Maintaining Your Stove's Appearance.....	37
Comfort Control.....	34	Mobile Home Requirements .....	8
Continuous Pilot / GreenSmart™ Pilot Switch .....	35	Normal Operating Odors.....	36
Dimensions & Weight.....	6	Normal Operating Sounds .....	36
Electrical Requirements .....	9	Packing List.....	7
Electrical Specifications .....	6	Replacement Parts List.....	39
Face and Glass Removal.....	25	Starting the Stove for the First Time .....	34
Floor Protection Requirements .....	9	Steps for Finalizing the Installation .....	23
Fuel .....	6	Stove Clearances.....	8
Gas Line Installation.....	11	Troubleshooting Table .....	39
GS2 Remote Installation .....	46	Turning the Stove On and Off.....	34
Heater Placement Requirements .....	9	Vent Requirements .....	12
Heating Specifications.....	6	Vent Termination Requirements.....	20
Horizontal Termination with One 90° Elbow ....	15	Vertical Terminations with Three 90° Elbows ..	19
Horizontal Termination with Three 90° Elbows (all vertical).....	17	Vertical Terminations with Two 90° Elbows.....	18
Horizontal Termination with Two Elbows .....	16	Vertical Terminations with Zero, Two, or Four 45° Elbows.....	14
Important Information.....	2	Yearly Service Procedure .....	38