

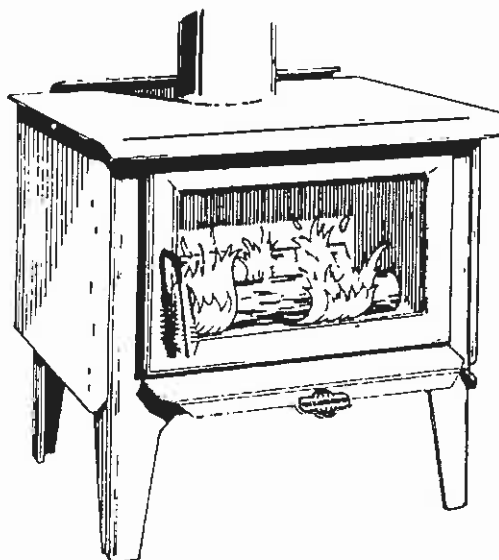

INSTALLATION AND OPERATION MANUAL

**EPA CERTIFIED
NONCATALYTIC
FREESTANDING
WOODSTOVE**



RETAIN THESE
INSTRUCTIONS
FOR FUTURE
REFERENCE

MODEL 1400HT

**THIS APPLIANCE MUST BE INSTALLED BY A QUALIFIED TECHNICIAN.
READ MANUAL THOROUGHLY BEFORE INSTALLATION.**

Tested &
Listed By



Beaverton
Oregon USA

OMNI - Test Laboratories, Inc.

P/N 775000M, Rev. E, 04/02

IMPORTANT WARNINGS

CAUTION: PLEASE READ THIS ENTIRE MANUAL BEFORE YOU INSTALL AND USE YOUR NEW ROOM HEATER. FOR YOUR SAFETY, FOLLOW THE INSTALLATION, OPERATION AND MAINTENANCE INSTRUCTIONS EXACTLY, WITHOUT DEVIATION. FAILURE TO FOLLOW THESE INSTRUCTIONS MAY RESULT IN PROPERTY DAMAGE, BODILY INJURY, OR EVEN DEATH. IF THIS APPLIANCE IS NOT PROPERLY INSTALLED, A HOUSE FIRE MAY RESULT. CONTACT YOUR LOCAL BUILDING OR FIRE OFFICIALS ABOUT RESTRICTIONS AND INSTALLATION INSPECTION REQUIREMENTS IN YOUR AREA.

1. If utilizing an older chimney, it must be inspected for adequate serviceability. Refer to the heading *Chimney Inspection* on page 8 of this manual.
2. The minimum clearances must be maintained for all combustible surfaces and materials including; furniture, carpet, drapes, clothing, wood, papers, etc. Do not store firewood within this clearance space. Failure to maintain clearances to all combustibles may result in a house fire.
3. This appliance requires non-combustible floor protection as outlined in this manual (see *Floor Protection* on page 6 for additional information).
4. Minimum ceiling height must be 7 feet (213 cm) (measured from base of appliance to ceiling).
5. **DO NOT CONNECT THIS UNIT TO A CHIMNEY FLUE CONNECTED TO ANOTHER APPLIANCE.**
6. Do not connect this appliance to air ducts or any air distribution system.
7. **PREVENT CREOSOTE FIRE:** Inspect and clean chimney frequently. Under certain conditions of use, creosote buildup may occur rapidly. Inspect chimney connector and chimney twice monthly and clean if necessary. Using green or inadequately seasoned wood can greatly increase creosote buildup. Use dry wood to minimize creosote buildup.
8. **USE SOLID WOOD FUEL ONLY:** This appliance is approved for burning dry seasoned natural wood only. **CAUTION: BURN UNTREATED WOOD ONLY. DO NOT BURN GARBAGE OR FLAMMABLE FLUIDS SUCH AS GASOLINE, NAPHTHA OR ENGINE OIL.**
9. Never use gasoline, gasoline-type lantern fuel, kerosene, charcoal lighter fluid, or similar liquids to start or "freshen up" a fire in this heater. Keep all such liquids well away from the heater while it is in use.
10. **DO NOT OVERFIRE:** If heater or chimney connector glows, you are overfiring. Overfiring this appliance could cause a house fire. Overfiring is a condition where the appliance is operated at temperatures above its design capabilities. Overfiring can be caused by improper installation, improper operation, lack of maintenance or improper fuel usage. Damage caused from overfiring is NOT covered under the manufacturer's limited warranty.
11. **NEVER LEAVE AN UNATTENDED STOVE BURNING ON HIGH.** Operation of the stove with the primary air control at its highest burn rate setting for extended periods can cause dangerous overfiring conditions. The primary air control should only be positioned at the highest setting during start-up procedures and for short durations. When leaving the stove unattended ensure that the primary air control is set to the low or medium low range.
12. Use a metal container with a tight fitting lid to dispose of ashes.
13. **IN THE EVENT OF A COMPONENT FAILURE, USE ONLY COMPONENTS PROVIDED BY THE MANUFACTURER AS REPLACEMENT PARTS.**
14. Burning any kind of fuel uses oxygen from the dwelling. Be sure that you allow an adequate source of fresh air into the room where the stove is operating (see *Ventilation and Outside Air* on page 6).
15. **CAUTION: HOT WHILE IN OPERATION.** An appliance hot enough to warm your home can severely burn anyone touching it. Keep children, clothing and furniture away. Contact may cause skin burns. Do not let children touch the appliance. Train them to stay a safe distance from the unit.
16. Do not operate this appliance without the fire-box baffle brick properly installed.
17. Build fires directly upon the brick hearth inside the stove. Do not use grates, irons or any other method to elevate the fire.
18. **SAVE THESE INSTRUCTIONS.**
19. See the listing label located on the back of stove (or see Safety/Listing Label on page 22).

TABLE OF CONTENTS

Important Warnings	2
Testing/Listing, EPA, Using this Manual	3
Planning Your Installation	4-6
Manufactured (Mobile) Home Requirements	6
Installation	7-11
Product Features and Controls	12
Care and Operation.....	12-13
Recommended Fuel.....	14
Maintenance.....	14-15
Troubleshooting	16-17
Specifications	18
Replacement Parts List.....	19-20
Optional Accessories	21
Safety/Listing Label	22
EPA Label	23
Ownership Records	24

TESTING/LISTING

Model 1400HT has been tested to UL Standards 1482 and ULC-S627 for installation in residential and manufactured (mobile) home construction. The listing laboratory is OMNI Environmental Services, Beaverton, Oregon, Report #030-S-03-02.

EPA CERTIFICATION

This stove has been tested to rigorous emissions standard, and has been certified by the Environmental Protection Agency.

PACKAGING LIST

This appliance is packaged with an accessory package, which contains the following:

- One - Installation and operation instructions manual.
- One - Warranty.
- Five - Baffle brick.

USING THIS MANUAL

Please read and carefully follow all of the instructions found in this manual. Please pay special attention to the safety instructions provided in this manual. The Homeowner's Care and Operation Instructions included here will assure you have many years of dependable and enjoyable service from your appliance.

CONGRATULATIONS ON THE PURCHASE OF YOUR NEW WOODSTOVE MANUFACTURED BY LENNOX HEARTH PRODUCTS.

When you purchased your new woodstove, you joined the ranks of thousands of concerned individuals whose answer to their home heating needs reflects their concern for aesthetics, efficiency and our environment. We extend our continued support to help you achieve the maximum benefit and enjoyment available from your new wood stove.

It is our goal at Lennox Hearth Products to provide you, our valued customer, with an appliance that will ensure you years of trouble free warmth and pleasure.

Thank you for selecting a Lennox Hearth Products stove as the answer to your home heating needs.

Sincerely,
All of us at Lennox Hearth Products

PLANNING YOUR INSTALLATION

QUESTIONS TO ASK LOCAL BUILDING OFFICIAL

A correct installation is critical and imperative for reducing fire hazards and perilous conditions that can arise when wood burning appliances are improperly installed. The installer must follow all of the manufacturer's instructions.

The installation of a wood burning appliance must conform to local codes and applicable state and federal requirements. Familiarity with these requirements before installation is essential. Important considerations to discuss with local building officials include:

1. Applicable codes (i.e. Uniform Mechanical Code, State or Regional Codes)?
Electrical codes: Optional Blower Assemblies have a flexible electrical cord that must be electrically grounded per local codes or per electrical codes:
In USA, NEC, ANSI/NFPA 70-1987
In Canada, CSA C22.1

WARNING: ELECTRICAL GROUNDING INSTRUCTIONS: THIS APPLIANCE IS EQUIPPED WITH A THREE-PRONG (GROUNDING) PLUG FOR YOUR PROTECTION AGAINST SHOCK HAZARD AND SHOULD BE PLUGGED DIRECTLY INTO A PROPERLY GROUNDED THREE-PRONG RECEPTACLE. DO NOT CUT OR REMOVE THE GROUNDING PRONG FROM THIS PLUG.

DO NOT ROUTE POWER CORD UNDER OR IN FRONT OF APPLIANCE.

2. Local amendments?
3. Is a permit required - cost? (You may wish to contact your insurance company to ask if they require this).
4. Is outside combustion air required?
5. Rooms where the installation is not allowed?

SMOKE DETECTORS

Since there are always several potential sources of fire in any home, we recommend installing smoke detectors. If possible, install the smoke detector in a hallway adjacent to the room (to reduce the possibility of occasional false activation from the heat produced by the stove). If your local code requires a smoke detector be installed within the same room, you must follow the requirements of your local code. Check with your local building department for requirements in your area.

NOTE – This appliance is NOT approved for installation into a Manufactured (Mobile) Home in Canada

SELECTING A LOCATION

The design of your home and where you place your stove will determine its value as a source of heat. A wood stove depends primarily on air circulation (convection) to disperse its heat, and therefore, a central location is often best. There are other practical considerations, which must be considered before a final selection of locations is made.

- ◆ Existing Chimneys
- ◆ Wood Storage
- ◆ Aesthetic Considerations
- ◆ Roof Design (Rafter Locations & Roof Pitch)
- ◆ Room Traffic
- ◆ Proximity to Combustibles
- ◆ Electrical Wiring

The installation of this stove will require some research. Once your options are determined, consult with your local building department who will be able to give you the necessary installation requirements for your area (Is a building permit required, Rooms where installation may not be allowed, etc.).

WARNING: CHECK ALL LOCAL BUILDING AND SAFETY CODES BEFORE INSTALLATION. THE INSTALLATION INSTRUCTIONS AND APPROPRIATE CODE REQUIREMENTS MUST BE FOLLOWED EXACTLY AND WITHOUT COMPROMISE. ALTERATIONS TO THE STOVE ARE NOT ALLOWED. DO NOT CONNECT THE STOVE TO A CHIMNEY SYSTEM SERVING ANOTHER STOVE, APPLIANCE, OR ANY AIR DISTRIBUTION DUCT. FAILURE TO FOLLOW THESE INSTRUCTIONS WILL VOID THE MANUFACTURER'S WARRANTY.

If you plan to vent your stove into an existing masonry chimney, have it inspected by a local fire marshal or qualified installer. Remember that a stove's performance is heavily influenced by the chimney and its location on the roof. An oversized flue may not provide effective draw, and a flue liner may be required (see *Draft Requirements* on page 9). Consult your dealer or qualified installer before final selection is made.

This stove requires pre-installation work to be completed before installation can take place. This will include the preparation of the floor and appropriate hearth pad for acceptance of outside air (if applicable), and for modification for flue and chimney.

PLANNING YOUR INSTALLATION

COMBUSTIBLE WALL CLEARANCE

WARNING: IT IS VERY IMPORTANT THAT YOU OBSERVE THE MINIMUM CLEARANCES.

There are listed clearances for your stove which were determined in a Laboratory test using various "classes" of stove pipe or chimney. Minimums are first established for the stove itself and increased based on how much heat is transferred by each class of pipe.

Note: Manufactured (mobile) home installations require the use of a Type L Vent Chimney connector only. Use of a single wall flue pipe connection is not permitted.

Residential Reduced Clearance

Using Listed L-Vent pipe (double wall air insulated) to the top of the stove. Approved brands are: Jakes-Evans, Dura-Vent, Security, Pro-Vent, Ameri-Tek, Metal Bestos.

Clearances (Inches / millimeters)

- | | | |
|-----------------|-------------|----------------|
| A. 10 1/2 / 267 | C. 15 / 381 | E. 9 1/2 / 241 |
| B. 20 / 508 | D. 8 / 203 | F. 5 / 127 |

Residential Standard (not approved for manufactured [mobile] homes)

Using single wall pipe connector to the top of the stove.

Clearances (Inches / millimeters)

- | | | |
|-------------|-------------|----------------|
| A. 15 / 381 | C. 15 / 381 | E. 8 1/2 / 216 |
| B. 19 / 483 | D. 13 / 330 | F. 5 / 127 |

Manufactured (Mobile) Home Standard Clearance

Using Approved L-Vent only. Approved brands are Dura-Vent, Security, Pro-Vent, and Ameri-Tek. Manufactured (Mobile) Home installations must use a rain cap with a spark arrester.

Clearances (Inches / millimeters)

- | | | |
|-----------------|-------------|----------------|
| A. 10 1/2 / 267 | C. 15 / 381 | E. 9 1/2 / 241 |
| B. 20 / 508 | D. 8 / 203 | F. 5 / 127 |

CORNER INSTALLATION

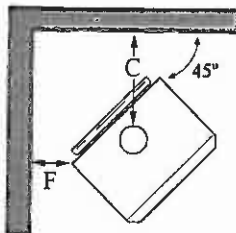

PARALLEL INSTALLATION

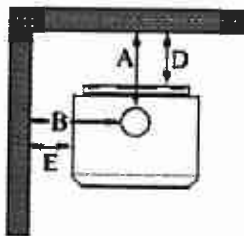

*ALCOVE CLEARANCE

Required pipe: Type L-Vent pipe to top of stove. Approved brands are Dura-Vent, Pro-Vent, Ameri-I-Tek, Standex, and Metal Bestos.

Alcoves must have minimum dimensions of 84" (213 cm) height minimum, 46" (117 cm) width minimum and 24" (610 mm) depth maximum.

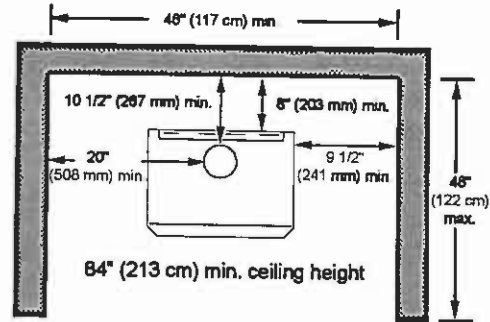

ALCOVE CLEARANCES:

- | | |
|------------------------|--------------------------|
| Back wall to pipe O.D. | 10 1/2" (267 mm) Minimum |
| Side wall to pipe O.D. | 20" (508 mm) Minimum |
| Back wall to stove | 8" (203 mm) Minimum |
| Side wall to stove | 9 1/2" (241 mm) Minimum |

* NOTE: Alcove dimensions cannot be reduced by the use of non-combustible materials such as brick, stone, etc. Alcove dimensions listed are minimum dimensions and are not measurements for building an Alcove. You will need to consider these clearances, as well as other dimensional requirements before you build the alcove and install this appliance.

OPTIONAL ARCH TREATMENT

An alcove depth of 24" (610 mm) (or less) will allow for a minimum height of 84" (213 cm) and may be trimmed with a 2 1/4" (57 mm) maximum arch treatment if desired.

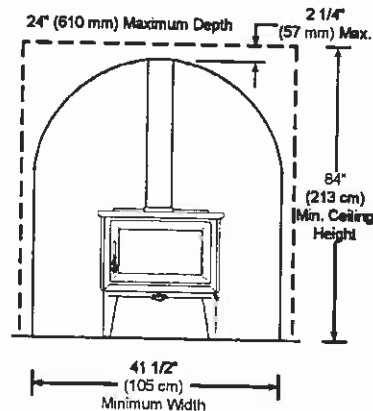

PLANNING YOUR INSTALLATION

REDUCED MASONRY STRUCTURE CLEARANCE (ALCOVE)

Your Earth Stove can be installed in a masonry structure with reduced clearances if the structure was built to National Building Code for fireplaces and chimneys (UBC 37).

The firebox of the masonry structure must be of adequate size to allow a minimum of 6" (152 mm) clearance to the sides and top of the stove and 2" (51 mm) clearance to the rear. All stove models must be installed on their original listed legs or base unless otherwise specified by OMNI Testing Laboratory.

FLOOR PROTECTION

This appliance requires a non-combustible floor protection for ember protection. If the floor protection is to be stone, tile, brick, etc., it must be mortared or grouted to form a continuous non-combustible surface. If a chimney connector extends horizontally over the floor, protection must cover the floor under the connector and at least 2" (51 mm) to either side.

The floor protection must extend completely beneath the stove and to the front, sides, and rear as indicated:

USA Requirements

16" (406 mm) min. to the front of the fuel door glass
8" (203 mm) min. beyond the sides of the fuel door opening

Canada Requirements

18" (457 mm) min. to the front of the fuel door glass
8" (203 mm) min. beyond the sides of the stove body

STANDARD PARALLEL HEARTH PAD SHOWN

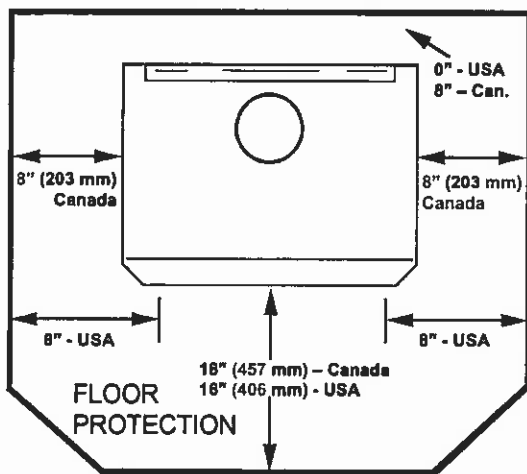

PROTECTED WALL CLEARANCE

Some local codes will allow reduced clearances when the stove is installed adjacent to a protected wall system. The variance must be approved by your local building official. Normally, the protected wall system is defined as a non-combustible material with a minimum of 1" (25.4 mm) air space behind. Check your local building codes or with a qualified installer (Ref. NFPA 211).

VENTILATION REQUIREMENTS

THE FRESH AIR REQUIREMENTS OF THIS APPLIANCE MUST BE MET WITHIN THE SPACE WHERE IT WILL BE INSTALLED.

Ventilation is essential when using a solid fuel burning heater. The combustion process of this heater uses oxygen from inside the dwelling and it may be necessary to open a window or to duct outside combustion air directly to the appliance (as outlined in this manual). Modern construction standards have resulted in homes that are highly energy-efficient and that allow little heat loss and air transfer. Other appliances in the dwelling also contribute to removing air from the dwelling (i.e. clothes dryers, exhaust fans, fireplaces, and other fuel burning appliances). If the available fresh air delivery in the dwelling is insufficient to support the demands of these appliances, problems can result (i.e. excessive negative pressure can develop in the dwelling which will affect the rate at which this appliance can draft [see *Draft Requirements* on page 9], icing can develop in some environments, etc.).

OUTSIDE AIR

In all manufactured (mobile) homes and in many site built residences (subject to local code), a stove may be required to use outside air for combustion. A 3" (76 mm) diameter outside air floor duct is available through your dealer.

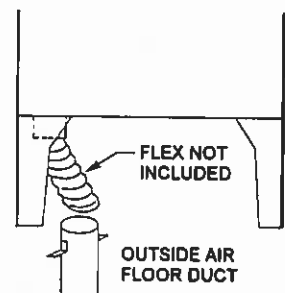

This appliance utilizes a 3" (76 mm) diameter outside air floor duct (Catalog # 14M66). Outside air can be taken from beneath the home or through an outside wall. The collar for connecting flex to stove is on the underside of the stove as shown here.

INSTALLATION

MANUFACTURED (MOBILE) HOME REQUIREMENTS

This stove is certified as a Room Heater, Solid Fuel Type and may be used in Manufactured Housing providing the following requirements are followed:

- An outside air inlet must be provided for combustion and be unrestricted while unit is in use.
- **WARNING: DO NOT INSTALL APPLIANCE IN A SLEEPING ROOM.**
- **CAUTION: THE STRUCTURAL INTEGRITY OF THE MOBILE HOME FLOOR, WALL, AND CEILING/ROOF MUST BE MAINTAINED.**
- Regulations require that the appliance must be secured to the floor and grounded to the chassis. See *Securing the Stove to the Floor (and) Grounding Stove* below.
- Required venting is 6" (152 mm) diameter Type L-Vent connector pipe with listed factory-built 103HT chimney suitable for use with solid fuels or a code approved masonry chimney. Approved brands of factory built chimney are listed in this manual. A rain cap and spark arrestor are required (see *Clearances*, page 5).
- The chimney must provide for a section joint so that any parts extending above 13' 6" (343 mm) from ground level can be removed for transportation of the mobile dwelling.

SECURING THE STOVE TO THE FLOOR

Manufactured (Mobile) Homes Only

Once the outside air floor duct is in position, replace the floor protector. Make sure that the floor protector's hole is aligned with the outside air opening. Next position and align the stove on the hearth pad. Manufactured (Mobile) home installations require that the stove be secured to the floor.

This ensures that the stove will not shift when the manufactured (mobile) home is moved. To do this, mark where the holes are to be drilled using a marking instrument long enough and small enough to fit through the (4) four holes in the stove legs. Mark holes, then remove the stove. Drill the (4) four holes, with a 1/4" (7 mm) drill bit. Drill down through the floor protector and the manufactured (mobile) home floor. Use 1/4" (7 mm) lag bolts and secure to the manufactured (mobile) home floor.

NOTE: If the composition of the manufactured (mobile) home floor is of light particleboard construction, you will be required to secure the stove with regular hex head bolts and nuts. This will ensure that the bolts will not rip out of the floor when the manufactured (mobile) home is being moved.

GROUNDING STOVE

Manufactured (Mobile) Homes Only

Regulations require that all stoves installed in manufactured (mobile) homes must be grounded. To do this simply attach a piece of No. 8 copper wire, at least 18" (457 mm) in length from the stove to the chassis of the manufactured (mobile) home.

INSTALLING THE BAFFLE BRICK

There are 2 brick retainer tube assemblies located below the ceiling of the firebox which require baffle brick before the stove can be operated. Install the baffle brick as follows:

1. Place the first three brick onto the brick retainers with the notch facing up and toward the front. Next, slide the three brick all the way to the right (as you face the stove. See top view illustration below).
2. Place the fourth brick on top of the three brick. Position it so the notch is facing up and pointing to the left.
3. Install the fifth brick and slide all the way to the left.
4. Rotate the fourth brick into position (notch to the front and facing up) until it drops into place.

IMPORTANT: The baffle brick requires periodic inspection and replacement for proper operation. If the baffle brick are fractured or crumbling, they should be replaced. Do not operate this appliance without the baffle brick properly installed.

TOP VIEW OF BAFFLE BRICK

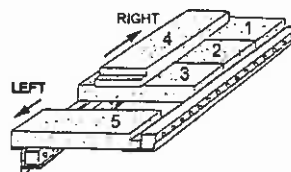

SIDE VIEW OF BAFFLE BRICK

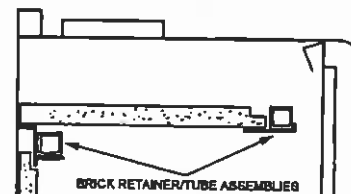

INSTALLATION

TYPES OF CHIMNEYS

The chimney is a vital part of your stove installation. A properly built masonry chimney or a properly installed factory built chimney will assure a consistent draft under a variety of weather conditions (a smoking stove is usually caused by a chimney problem). The stove flue size is 6 (152 mm) inches diameter, which is approximately 28 square inches (711 square mm) minimum. The maximum flue size should be no more than (3)-three times the cross sectional area of the size of the stove flue collar. In this case, that would be no larger than a 10-inch (254 mm) diameter stack, or approximately 85 square inches (216 square cm) maximum.

All chimneys must be installed as specified by local building codes and according to the chimney manufacturer instructions (in the case of a factory built chimney). See the chimney manufacturer instructions for exact specifications. Factory built chimneys must comply with UL 103HT or ULC S629.

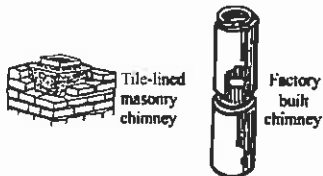

ACCEPTABLE CONNECTOR PIPE FOR INSTALLATIONS

For Standard Residential Clearances: Six (6) inch (152 mm) minimum, single wall, 25 gage minimum thickness, stove pipe is acceptable. Three (3) pre-drilled holes are provided in the flue collar for fastening the pipe securely to the stove. Use sheet metal screws to do this. Additional sections of single wall pipe should be fastened together with at least three (3) sheet metal screws each section. When connecting to the factory built ceiling support package, use the manufacturer's transition piece, usually called a dripless connector, to join single wall pipe to their factory built chimney section.

Minimum Flue Size: The required minimum diameter and area required for the flue size is (respectively) 6 inches / 152 mm diameter, which is approximately 28 square inches / 711 square mm. The maximum flue size should be no more than (3) three times the cross sectional area of the size of the 6 inches / 152 mm diameter flue collar. In this case, that would be no larger than a 10 inch (254 mm) diameter (area = approx. 85 sq. inches [216 sq. cm]).

Connection To A Factory Built Chimney: This space heater is to be connected to a factory-built chimney conforming to CAN / ULC – S629, Standard for 650°C Factory-Built Chimneys.

For Reduced Residential Clearances: Type L and listed double wall connector pipe is acceptable. Install any factory built brand of pipe according to the manufacturer's instructions.

Vapor Barrier at Chimney Penetration

Install all venting components per the Vent Manufacturer's installation instructions. Ensure that there is an effective vapor barrier at the location where the chimney penetrates to the exterior of the structure. This can be accomplished by applying a non-hardening waterproof sealant to the following components:

- Around the chimney at the point where the storm collar will meet the chimney just above the Flashing.
- Along the vertical seam of the chimney pipe, where it is exposed to the weather.
- On each nail head on the flashing.
- Around the chimney at the point where the storm collar will meet the chimney just above the flashing.

Notes:

- On a flat or tarred and graveled roofs, nail and seal the flat roof flashing to the roof on all sides with roofing compound.
- Do not put screws through the flashing into the chimney pipe.

CHIMNEY INSPECTION

Existing chimneys must be inspected before installing your stove. Consult your local building department for chimney code requirements. A masonry chimney must have a code approved liner. This liner must not have broken or missing pieces. Some non-code masonry chimneys may be brought up to code by being relined. (Consult your dealer or qualified chimney sweep). Factory built chimneys should also be inspected, first for creosote deposits (which should be removed), and then for integrity of the stainless steel liner. Look for obvious bulges in the lining which may indicate the need to replace that section (use a bright flashlight). Also, inspect the attic to see that the chimney has proper clearance to combustible framing members. For interior masonry chimneys and most factory built chimneys, this must be a (2) two inch (51 mm) air space clearance, which must not be filled with insulation or any other material. An exterior masonry chimney must have a (1) one-inch (25.4 mm) air space clearance.

INSTALLATION

CHIMNEY HEIGHT REQUIREMENTS

The chimney must extend 3 feet (915 mm) above the level of roof penetration and a minimum of 2 feet (610 mm) higher than any roof surface within 10 feet (305 cm) (see below). Check with your local building officials for any additional requirements for your area.

Due to prevailing winds, local terrain, adjacent tall trees, a hill, or ravine near the home, or adjacent structures, additional chimney height or a special chimney cap may be required to ensure optimum performance.

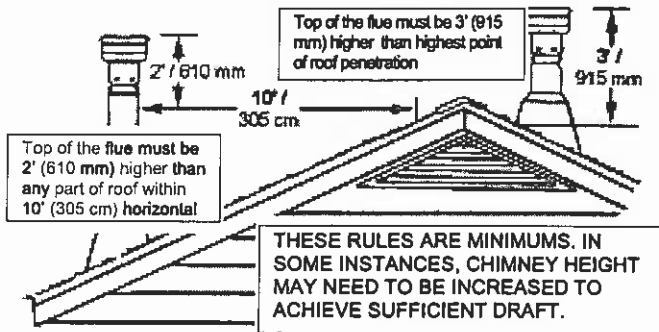

To achieve a stable draft, the total flue height required (from the appliance to termination) is 12 to 15 feet (366 to 457 cm) minimum.

For Manufactured (Mobile) Homes Only: Portions of the chimney and termination that exceed an elevation of 13½ feet above ground level may be designed to be removed for transporting the manufactured home.

DRAFT REQUIREMENTS

The appliance is merely one component of a larger system. The other equally important component is the venting system. This is necessary for achieving the required flow of combustion air to the fire chamber and for safely removing unwanted combustion byproducts from the appliance. If the venting system's design does not promote these ends, the system may not function properly. Poorly functioning venting systems may create performance problems as well as be a safety hazard (i.e. an oversized chimney may result in less than optimum performance. Installations into a large, masonry chimney may require a liner to improve performance). A draft test should read greater than .04' W.C. (inches water column) and less than .08" W.C.

American National Standards Institute ANSI/NFPA 211-92, draft 1-7: A chimney or vent shall be so designed and constructed to develop a flow sufficient to completely remove all flue and vent gases to the outside atmosphere. The venting system shall satisfy the draft requirements of the connected appliance in accordance with the manufacturer's instructions.

INSTALLATION

RESIDENTIAL STANDARD

Using 6" (152 mm) Diameter Single Wall Connector Pipe. Not Approved For Manufactured (Mobile) Homes.

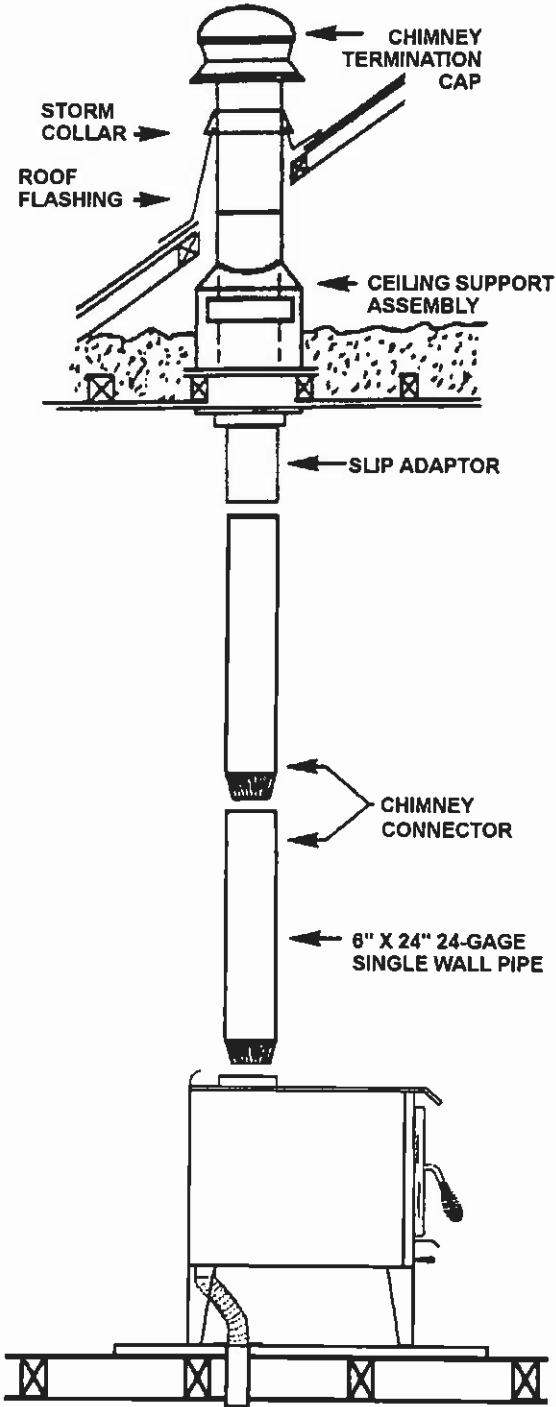

MANUFACTURED (MOBILE) HOME STANDARD

Using 6" (152 mm) Diameter Type L-Vent Connector Pipe

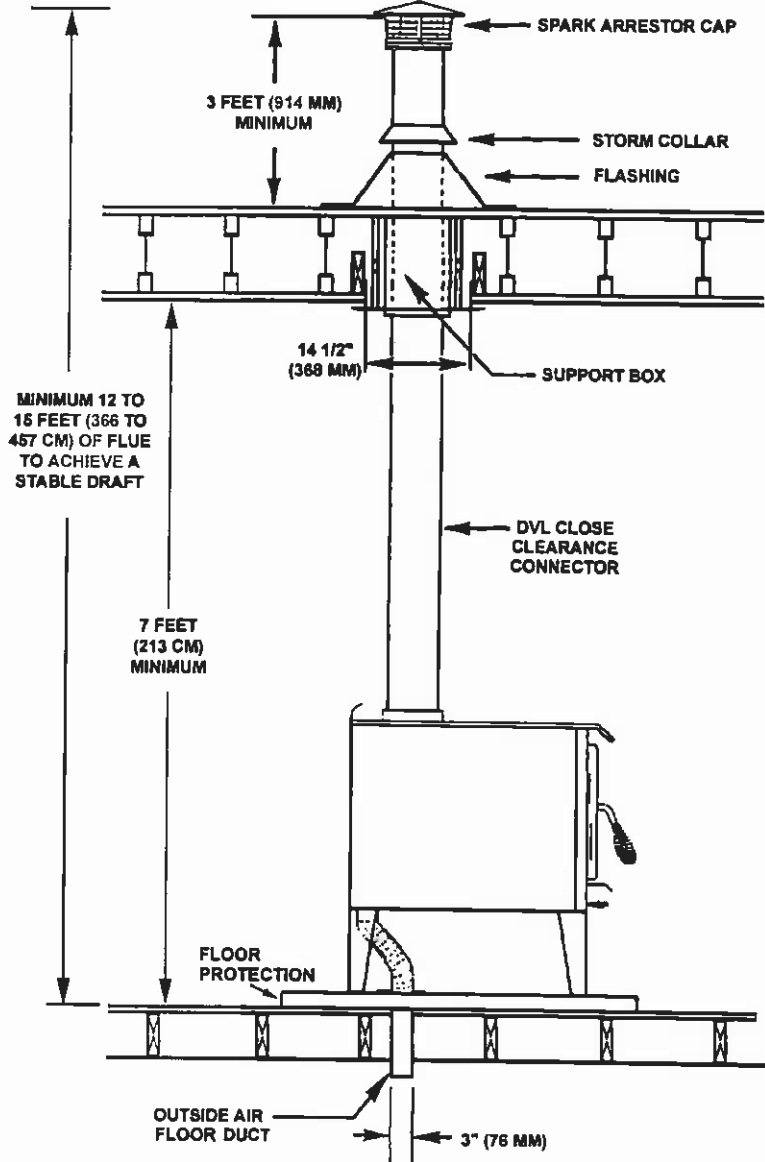

INSTALLATION

Combustible Wall Chimney Connector Pass-Throughs

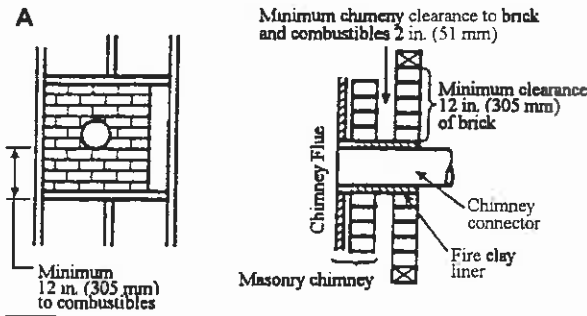

Method A. 12 inch (305 mm) Clearance to Combustible Wall Member: Using a minimum thickness 3.5 inch (90 mm) brick and a 5/8 inch (16 mm) minimum wall thickness clay liner, construct a wall pass-through. The clay liner must conform to ASTM C315 (Standard Specification for Clay Fire Linings) or its equivalent. Keep a minimum of 12 inches (305 mm) of brick masonry between the clay liner and wall combustibles. The clay liner shall run from the brick masonry outer surface to the inner surface of the chimney flue liner but not past the inner surface. Firmly grout or cement the clay liner in place to the chimney flue liner.

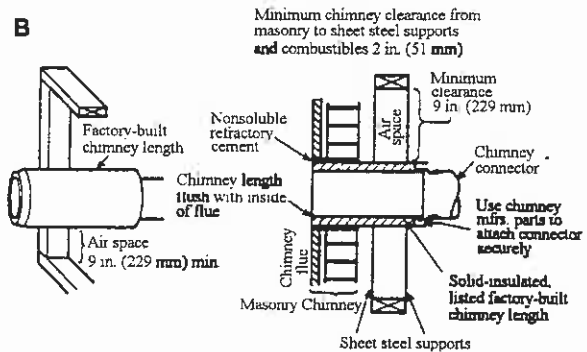

Method B. 9 inch (229 mm) Clearance to Combustible Wall Member: Using a 6 inch (152 mm) inside diameter, listed, factory-built Solid-Pak chimney section with insulation of 1 inch (25.4 mm) or more, build a wall pass-through with a minimum 9 inch (229 mm) air space between the outer wall of the chimney length and wall combustibles. Use sheet metal supports fastened securely to wall surfaces on all sides, to maintain the 9 inch (229 mm) air space. When fastening supports to chimney length, do not penetrate the chimney liner (the inside wall of the Solid-Pak chimney). The inner end of the Solid-Pak chimney section shall be flush with the inside of the masonry chimney flue, and sealed with a non-water soluble refractory cement. Use this cement to also seal to the brick masonry penetration.

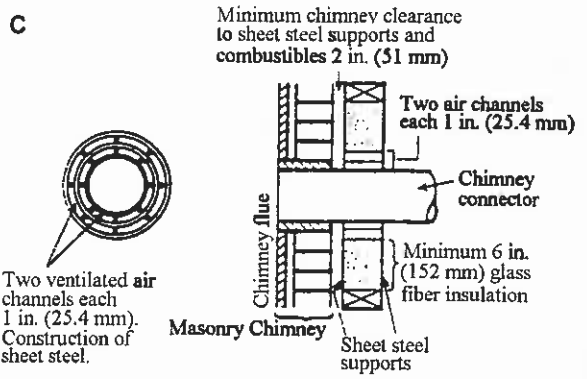

Method C. 6 inch (152 mm) Clearance to Combustible Wall Member: Starting with a minimum 24 gage (.024 inch [.61 mm]) 6-inch (152 mm) metal chimney connector, and a minimum 24 gage ventilated wall thimble which has two air channels of 1 inch (25.4 mm) each, construct a wall pass-through. There shall be a minimum 6 inch (152 mm) separation area containing fiber glass insulation, from the outer surface of the wall thimble to wall combustibles. Support the wall thimble, and cover its opening with a 24-gage minimum sheet metal support. Maintain the 6 inch (152 mm) space. There should also be a support sized to fit and hold the metal chimney connector. See that the supports are fastened securely to wall surfaces on all sides. Make sure fasteners used to secure the metal chimney connector do not penetrate chimney flue liner.

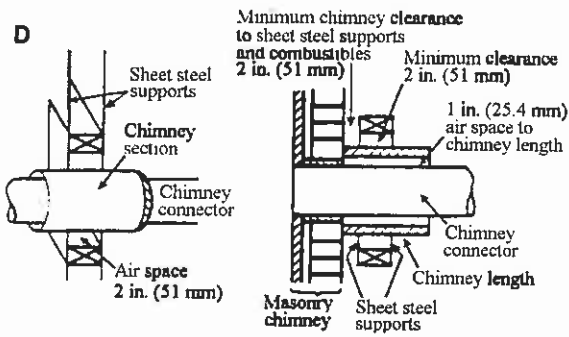

Method D. 2 inch (51 mm) Clearance to Combustible Wall Member: Start with a solid-pak listed factory built chimney section at least 12 inches (305 mm) long, with insulation of 1 inch (25.4 mm) more, and an inside diameter of 8 inches (203 mm) (2 inches [51 mm] larger than the 6 inch [152 mm] chimney connector). Use this as a pass-through for a minimum 24-gage single wall steel chimney connector. Keep solid-pak section concentric with and spaced 1 inch (25.4 mm) off chimney connector by way of sheet metal support plates at both ends of chimney section. Cover opening with and support chimney section on both sides with 24 gage minimum sheet metal supports. See that the supports are fastened securely to wall surfaces on all sides. Make sure fasteners used to secure chimney section do not penetrate chimney flue liner.

NOTES:

1. Connectors to a masonry chimney, excepting method B, shall extend in one continuous section through the wall pass-through system and the chimney wall, to but not past the inner flue liner face.
2. A chimney connector shall not pass through an attic or roof space, closet or similar concealed space, or a floor, or ceiling.
3. Where passage through a wall, or partition of combustible construction is desired, the installation shall conform to CAN/CSA-B385.

PRODUCT FEATURES AND CONTROLS

PRIMARY AIR CONTROL

The primary combustion air delivery is controlled by the Primary Air Control Assembly (The control handle is located below the fuel door). The heat output can be controlled by sliding the handle to a higher or lower heat output setting (See Care and Operation Section – *Primary Air Control*, page 12). The fuel, the amount of heat and burn times desired, the type of installation are all variables that will affect the control setting. The same control settings in a variety of installations will produce different results. You will need to try different settings so you can learn how much heat to expect and how long the fire will burn.

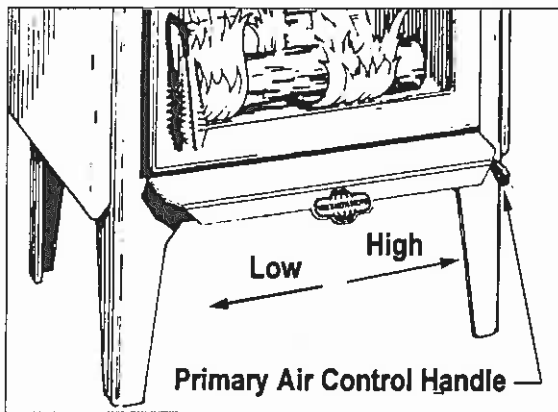

CARE AND OPERATION

FUEL DOOR

CAUTION: WHEN OPENING THE DOOR, DO NOT EXTEND IT BEYOND ITS NORMAL TRAVEL. OVEREXTENDING THE DOOR TO A FURTHER OPEN POSITION CAN PUT EXCESSIVE STRESS ON HINGE AREA OF DOOR AND HINGE PINS AND MAY RESULT IN BREAKAGE.

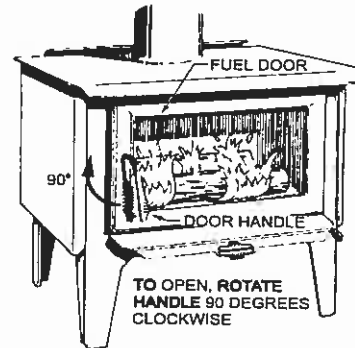

DOOR OPERATION

The door handle assembly opens and securely latches the fuel door closed. To open the door, rotate the coil handle to the 9:00 position until door releases. To close and latch, hold the coil handle in the 9:00 position, close the door, then rotate the handle to the 6:00 position. See illustration above.

GLASS

The Glass is a super heat resistant ceramic that withstands continuous temperatures up to 1390° F. This temperature is well beyond the temperatures in which you operate your stove.

This unit is designed to provide a flow of air over the inside of the glass, where along with high heat helps keep it clean. When operating the stove on low for extended periods of time, the glass may get dirty. A short, hot fire (15 - 20 minutes) will help clean off much of the normal buildup (see *Troubleshooting*, pages 16-17). A commercial glass cleaner designed for stoves is recommended for cleaning.

The glass should be cleaned thoroughly with glass cleaner and a soft cloth BEFORE the stove is burned.

CARE AND OPERATION

PRIMARY AIR CONTROL

This appliance is equipped with a control for the combustion air, located on the lower right side (front) of the stove. Sliding the control to the right increases the burn rate, to the left decreases the burn rate.

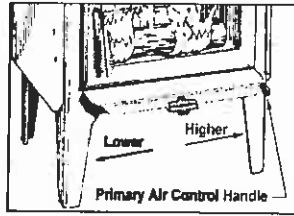

You will generally want to set the control in the low or medium range. The stove is safe burning on any setting as long as combustibles are kept at the specified safe distances.

PROVIDE ADEQUATE AIR FOR COMBUSTION

In well insulated and weather tight homes, it may be difficult to establish a good draft up your chimney. The poor draft is caused by a shortage of air in the house. To provide the needed air, crack a window on the windward side of the house.

In some cases, you may want to duct air directly from the outside to your firebox (See *Outside Air*, page 6), or to a nearby floor or wall vent.

USE CONTROL SETTINGS THAT WORK FOR YOU

The fuel, the amount of heat you want, the type of installation you have and how long you wish the fire to burn are all variables that will affect the control setting. The same control settings in a variety of installations will produce different results.

Familiarize yourself with your stove by trying different settings so you can learn how much heat to expect and how long the fire will burn. It may take a week or two to learn but your patience will be rewarded by the warmth and pleasant satisfaction that only a wood fire can provide.

BREAK-IN PERIOD

Your stove finish is a high temperature paint that requires time and temperature to completely cure. We recommend that you ventilate the house during the initial burns. The paint emits non-toxic odors during this process.

KEEP YOUR HOUSE WELL VENTILATED DURING THE CURING PROCESS TO PREVENT ACTIVATION OF YOUR HOME SMOKE DETECTOR.

The paint manufacturer recommends three burn cycles to cure the paint. The first two burns should be low heat, approximately 250°F., for 20 minutes each, using paper and light kindling.

After each 20-minute burn, allow the appliance to cool completely. The third burn should be at least medium high or about 450°F. for 45 - 60 minutes. The paint will become soft and emit non-toxic haze during these burns. Keep the area well ventilated.

As the paint cures it will become slightly lighter in color. Eventually the entire surface will become an even color. Once the paint has been softened and cooled two or three times, it will harden. Do not turn on a blower during the curing process. Do not place anything on the stove surface until the paint is completely cured. Do not attempt to repaint the stove until the paint is completely cured. If the surface later becomes stained or marred, it may be lightly sanded and touched up with spray paint from the same paint (See *Maintenance*, pages 14-15). Paint is available at your local authorized Lennox Hearth Products dealer. Never attempt to paint a hot stove.

HOW TO START AND MAINTAIN A FIRE

1. OPEN the Primary Air Control by sliding it to the right. This allows the firebox and fresh fuel to quickly come up to ideal operating temperature.
2. Build your fire directly on the Firebrick covering the bottom of the stove.
 - a. Place five or six loosely crumpled sheets of newspaper in the stove.
 - b. Add a small amount of dry kindling randomly on the top of the newspaper.
 - c. Place a few more loosely crumpled newspapers on top of the kindling and light the bottom paper first, then light the top paper. Once the fire is well underway, close the fuel door. The upper fire should preheat the chimney and create an effective draft while the lower fire ignites the kindling.
3. After the kindling is burning well, add increasingly larger pieces of wood until the fire is actively burning.
4. When the fire is well-established slide the air control lever for the desired heat output.

REFUELING

To refuel the stove, first slide the air control to high. Let the fire "liven up" for about one minute. Open the fuel door about 1/2" (1 cm) and hold in this position for 30 seconds or until stove is drafting well. Open door and add wood. If the fire or coal bed is almost depleted and a full load of cord wood is added, it may be necessary to leave the air control on the high setting for a while to re-establish a lively fire. Once the wood is burning at a brisk rate, slide the air control for the desired heat output.

FUEL

BURN RECOMMENDED FUEL

This appliance is approved for use with untreated natural dry wood only (see *Important Warnings*, page 2, #8). Do not burn particleboard scraps or pressed logs using bonding agents because they can produce conditions which will deteriorate metal. Green or uncured wood does not work well as fuel, and can cause increased creosote buildups. The value of green wood as a source of heat is limited. Do not overload or use kindling wood or mill ends as primary fuel as this may cause overfiring. Overfiring is a condition where excessive temperatures are reached, beyond the design capabilities of the stove. The damage that occurs from overfiring is not covered under the stove warranty.

WARNING: BURNING IMPROPER FUEL (I.E. CHARCOAL) CAN RESULT IN CARBON MONOXIDE POISONING WHICH MAY LEAD TO DEATH!

CARBON MONOXIDE POISONING – EARLY SIGNS OF CARBON MONOXIDE POISONING RESEMBLE THE FLU WITH HEADACHES, DIZZINESS, OR NAUSEA. IF YOU HAVE THESE SIGNS, GET FRESH AIR AT ONCE! HAVE THE HEATER INSPECTED BY A QUALIFIED SERVICE TECHNICIAN. SOME PEOPLE ARE MORE AFFECTED BY CARBON MONOXIDE THAN OTHERS. THESE INCLUDE PREGNANT WOMEN, PEOPLE WITH HEART OR LUNG DISEASE OR ANEMIA, THOSE UNDER THE INFLUENCE OF ALCOHOL, AND THOSE AT HIGH ALTITUDES.

WHY SEASONED WOOD?

The key to the success of a good fire that produces heat from a woodstove is the wood. It needs to be well-seasoned natural wood.

What does "Well-Seasoned" mean? When a tree is cut down, the wood is green, full of sap and moisture. This moisture content can exceed 80%, which must be reduced to less than 20%. Wood properly seasoned is then capable of generating the heat the stove was designed to provide. Green wood does not burn easily. Attempting to burn green wood often results in a lot of smoke and very little fire. Time is the most important factor in seasoning wood. Ideally the moisture content should be reduced to 11-20%, although very few of us will be able to check that figure. There are several steps that should be taken to ensure that you come close to these figures.

SEASONING GUIDE

Softwoods – 6 months to 18 months
Hardwoods – 12 months to 24 months

Logs that are 5" (127 mm) diameter across or larger should be split in half, three pieces if over 8 inches (203 mm), and four pieces when over a foot (305 mm) across. If the tree fell 2 to 4 years ago, it still needs to be cut, split, and seasoned for 6 to 24 months depending on the wood.

WOOD STORAGE

Wood to be seasoned should be stacked in an area open enough to ensure good air circulation on both sides – leaving adequate space between woodpiles to walk comfortable. Do not stack wood against a wall or building. It helps to elevate the woodpiles off the ground (two 2 x 4's running lengthwise beneath the woodpile works well). This allows air to flow under the bottom logs. Wood that is kept outdoors, either covered with a tarp, or not covered at all, will not burn well until it has been in an enclosed space for one to two months.

MAINTENANCE

SMALL AREA PAINT TOUCH-UP

The stove body is painted with a quality high-temperature stove paint. Use only model TSPK-B Stove Paint, Catalog # 70K99. Do not touch-up your stove with any other paint.

Using one small piece of 320 grit sand paper and lightly sand the blemish so that the edges are "feathered" or smooth to the touch between the painted and bare surfaces. Do not let the sand paper gum up with paint, as this will cause scratches on the metal surface. If there are any scratches, use 600 grit sandpaper instead. Mask off surfaces you do not want painted. Paint lightly over the bare surface first as this will act as an undercoat. Then paint over a larger area in smooth even strokes to blend.

See Break-In Period on page 13 for information on curing the paint.

ASH REMOVAL AND DISPOSAL

CAUTION: MAKE SURE THAT THE FIRE IS OUT AND THE STOVE IS COLD BEFORE REMOVING ASHES FROM FIREBOX!

Ashes can hold live embers for several days, and must be disposed of with care.

NEVER place ashes in a cardboard box or any other combustible receptacle.

Proper Disposal of Ashes:

Ashes should be placed in a metal container with a tight fitting lid. The closed container of ashes should be placed on a noncombustible floor or on the ground, well away from all combustible materials, pending final disposal. If the ashes are disposed of by burial in soil or other wise locally dispersed, they should be retained in the closed container until all cinders have thoroughly cooled.

DOOR AND GLASS GASKETS

A 3/4" (19 mm) spun fiberglass rope gasket provides the seal around the fuel door and a 1/8" x 1" (3 mm x 25.4 mm) flat woven gasket glass provides the seal around the glass. Should these gaskets become frayed or damaged they should be replaced with the same size and type as the original gasket. Contact your dealer for ordering. Use high temperature silicone sealer as an adhesive for the door gasket. The glass gasket has a self-adhesive backing (see *Replacement Parts*, pages 19-20).

WARNING: THE GASKETS MUST BE KEPT IN GOOD CONDITION. DO NOT LEAVE THE STOVE BURNING WITH THE DOOR OPEN OR AJAR. THIS WILL CAUSE EXCESSIVE HEAT BUILD UP IN THE UNIT AND COULD IGNITE SURROUNDING COMBUSTIBLES AS WELL AS DAMAGE THE STOVE BY OVERFIRING IT. OVERFIRING IS A CONDITION WHERE EXCESSIVE TEMPERATURES ARE REACHED, BEYOND THE DESIGN CAPABILITIES OF THE STOVE (SUCH DAMAGE IS NOT COVERED BY THE MANUFACTURER'S WARRANTY).

MAINTENANCE

SERVICING GLASS

CAUTION: BE CAREFUL NOT TO ABUSE DOOR ASSEMBLY BY STRIKING OR SLAMMING IT. IF THE DOOR ASSEMBLY OR GLASS IS BROKEN OR DAMAGED, THEY MUST BE REPLACED BEFORE HEATER CAN BE SAFELY OPERATED. USE ONLY COMPONENTS PROVIDED BY THE MANUFACTURER AS REPLACEMENT PARTS.

Cleaning Glass: Ensure stove is cold prior to cleaning glass. A commercial glass cleaner designed for stoves is recommended. Do not use abrasive cleaners.

Replacing Glass:

1. Remove door from stove by lifting door up and off hinge pins: Place the door on a flat protected (towel) clean flat surface with the inside of the door facing up. Remove the glass clips (by removing screws holding clips), then carefully remove broken glass one piece at a time (protective gloves are recommended).
2. Clean the area where the glass with gasket will be installed.
3. Install new glass with gasket (use only factory 5 mm glass with glass channel gasket. Do not substitute). Carefully reinstall glass clips. Be very careful not to overtighten screws.
4. Reinstall door.

CREOSOTE FORMATION AND NEED FOR REMOVAL

What Is Creosote - When wood is burned slowly, it produces tar and other organic vapors, which combine with expelled moisture to form creosote. The creosote vapors condense in the relatively cool chimney flue of a slow-burning fire. As a result, creosote residue accumulates on the flue lining. When ignited this creosote makes an extremely hot fire. Also, creosote deposits tend to form in long runs of venting where gases become too cool prior to exhausting. Note: Single wall pipe cools rapidly, therefore installations using this type of flue are more susceptible to creosote deposits.

To inhibit the build up of creosote, adjust the primary air control to a medium-high or high setting for a 10-minute period each day. Do not attempt to burn out heavy creosote accumulations in this manner. This must be removed from the chimney by scraping or brushing to reduce the risk of a chimney fire.

Burn Approved Fuel Only - This stove is approved for burning dry seasoned natural wood only. Using green or inadequately seasoned wood may increase creosote buildup.

Inspection Frequency - The chimney connector and chimney should be inspected at least twice monthly during the heating season to determine if a creosote buildup has occurred. If creosote has accumulated it should be removed to reduce the risk of a chimney fire.

Cleaning - Remove the brick baffle in the firebox prior to having your chimney cleaned (should be done by a qualified chimney sweep). See *Installing the Baffle Brick* on page 7 and reverse steps to remove baffle brick).

In the event of a chimney fire - Make sure the fuel door is securely closed. Adjust the primary air control to the lowest (most closed) setting. Call the fire department immediately. After a chimney fire, the complete chimney system should be checked by a qualified technician before further use.

Consult your dealer for suggestions on proper chimney care. Contact your local municipal or provincial fire authority for information on how to handle a chimney fire. Have a clearly understood plan for handling a chimney fire.

FIREBRICK

The firebrick should be inspected periodically and replaced if damaged (crumbling or excessively cracked).

REINSTALL Baffle BRICK

After your chimney has been swept, reinstall the brick baffle (see *Installing the Baffle Brick* on page 7).

CLEANING BLOWER INTAKE

If an optional blower kit (catalog #14M22) is installed, the blower air intake requires cleaning at least once a year to remove lint, dust, etc. If there are pets in the dwelling, the intake should be cleaned at least twice a year.

TROUBLESHOOTING

SMOKES OUT FUEL DOOR WHEN OPEN (see *)

1. The primary air control is closed.
2. The chimney is too cool. Set the primary air control on "HIGH" for a few minutes before opening the fuel door.
3. Excess creosote will not only restrict your draft but it will create a risk of a creosote fire. Strictly adhere to maintenance requirements as outlined in this manual. If excess creosote has built up on the inside of the firebox sides and door, burn a small hot fire at intervals that are more frequent with air control on HIGH for a few minutes.
4. Deposits may have built up in the chimney and are restricting the draft, or the spark arrester on top of the chimney may be plugged.
5. Chimney diameter too large or too small to provide adequate draft.
6. The house is too airtight (usually takes 20 to 30 minutes for problem to appear as stove lowers air pressure in house). Crack a window open or provide an outside source of air near stove.
7. Insufficient vertical height to chimney to achieve adequate draft.

DOES NOT PRODUCE ENOUGH HEAT (*)

1. Using green or insufficiently cured wood.
2. Excessive draft.
3. High ceilings (heat rises quickly, but can be recirculated by a well-placed ceiling fan with a winter/summer switch).
4. The area to heat is too large (square foot heating estimates are based on "average" climates and home design).
5. There is an obstruction in the chimney. The chimney or chimney cap is restricted by creosote preventing enough draw to sustain a "high" heat output rate.

DOES NOT MAINTAIN A FIRE (*)

1. Soft wood does not burn as long or as well as seasoned hardwood resulting in a short burn time.
2. Wood size too small. Burns at too rapid a rate.
3. The gasket seal on the fuel door or glass is leaking air. Repair or replace it if necessary.
4. Excessive Draft. There may be an obstruction in the chimney.

BACKPUFFING (*)

1. Downdraft in the chimney (a special wind cap may be needed).
2. The house is too air tight (ventilation is needed).
3. Insufficient vertical height to chimney to achieve adequate draft.

ODORS

1. Creosote accumulation in firebox (brush out on next cleaning).
2. Chimney downdraft when stove is not operating (close the primary air control).
3. Paint curing on first several burns.

DIRTY GLASS (*)

1. Poor draft conditions.
2. Long burn periods at low draft settings.
3. Burning wet, pitchy or spongy wood.
4. Poorly arranged logs (too close to glass).

(*) **Draft problems; If installing into a larger flue, it may be necessary to use a full length liner to achieve adequate draft for the appliance. A draft gauge should read a minimum of .05" w.c. (Inches water column) not to exceed .07" w.c. for optimum performance (See Draft Requirements, page 9).**

TROUBLESHOOTING

OVERFIRING DAMAGE

If the heater or chimney connector glows, you are overfiring. Other symptoms may include: Cracking, warping or burning out of components, stove glass may develop a haze, which will not come off with cleaning.

Overfiring of a stove is a condition where excessive temperatures are reached, beyond the design capabilities of the appliance. The damage that occurs from overfiring is not covered under the manufacturer's limited warranty.

The following are a few conditions that should be evaluated and (corrected if necessary) if an overfiring condition is suspected:

Overfiring Caused From Improper Installation - Ensure that all installation requirements have been met as outlined in the installation manual. The chimney should be clean and in good repair. A draft test should be performed to determine if the draft requirements of the appliance are being met. A draft gauge should read between .05 and .07 inches water column (" W.C.). Excessive draft (above .07 " W.C.) will allow too much combustion air to be pulled in which results in hotter burns. Too little draft (below .05 " W.C.) will not allow enough combustion air delivery to maintain a fire (this may result in improper operation of appliance, i.e. won't maintain fire unless fuel door is left open. See *Care and Operation* section).

Overfiring Caused From Improper Operation - Operate this appliance only as outlined in this manual. Never burn the appliance with the fuel door open or ajar. Do not operate this stove with the Air Control in the "open" position (pulled out) for extended periods. This wastes fuel and can cause dangerous overfiring conditions. NEVER leave the stove unattended on high settings.

Overfiring Caused From Improper Maintenance - Strictly adhere to all maintenance requirements at frequent intervals as prescribed in this manual including cleaning of flue and stove. Should the fuel door gasket or glass gasket become worn or damaged, it should be replaced.

Overfiring Caused From Improper Fuel - This appliance is approved for use with natural dry well seasoned wood only (ask your authorized dealer what are approved fuels for your area). Do not burn garbage, particleboard scraps, or pressed logs using bonding agents because they can produce conditions that will deteriorate metal. Do not overload or use kindling wood or mill ends as primary fuel as this may cause overfiring.

SPECIFICATIONS: Model 1400HT

Approx. heat capacity	~1500 Sq. Ft.* ~450 sq. M.
Outside air provision	Yes
Log length	20" (508 mm)
Flue position	Top
Flue collar size	6" (152 mm)
Width	27" (686 mm)
Depth	21 1/2" (546 mm)
Height (to flue)	28" (711 mm)
Height	26" (660 mm)
Approx. burn time	6 - 8 hours
Fuel capacity	35 lbs. (16 kg)
Firebox Size	1.85 cubic feet (564 cubic mm)
Maximum Burn Rate (BTU)	58,730
EPA BTU Range	11,700-37,000
EPA Efficiency	63%
Emissions Rate (grams/hour)	6.6 gph
Loading	Front
Approx. weight with brick	285 lbs. (130 kg)
Blower (Optional) W/ speed control	160 CFM, .9 amp, Rheostat (75v - 110v)

Note: Dimensions shown are approximations only (+/- 1/4" [6.4 mm])

~ Square feet (square meters) heating capacity and burn time are approximations only. They will vary depending upon the level of insulation, climate, house design, ceiling height, ambient outside temperatures and how the stove is operated.

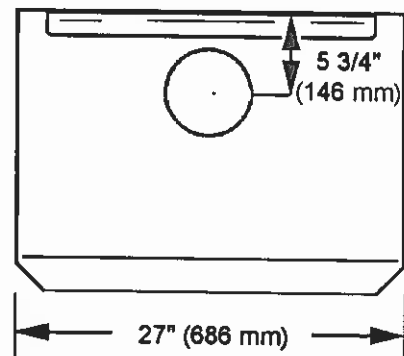
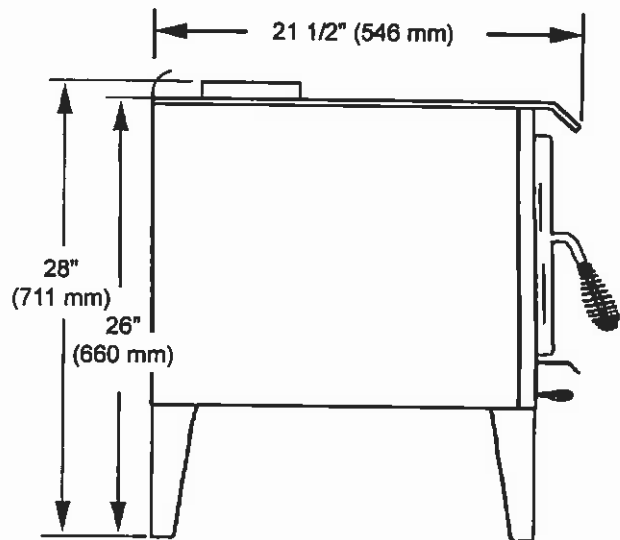
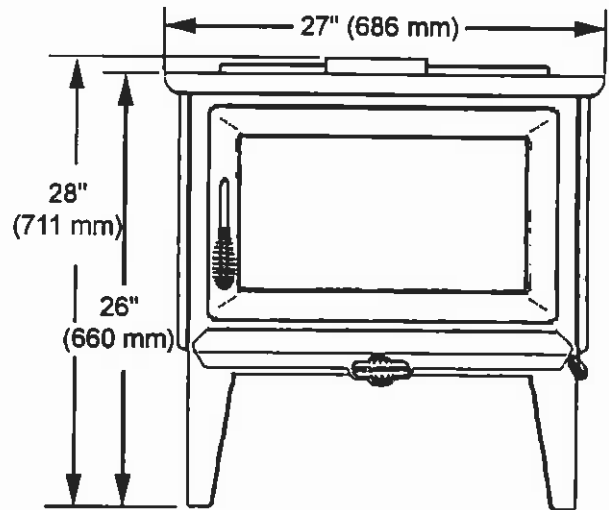

REPLACEMENT PARTS – Model 1400HT

PART NO. / CAT. NO.	DESCRIPTION
	Door Parts
10500	Door Assembly, Cast Black (handle included)
27M67	Clip Set, Glass
86-128	Door Gasket Kit, 3/4" Rope (includes adhesive)
27M81	Gasket, Glass Channel (self adhesive backed)
10514	Glass, Rectangular 9 1/2 X 17" (glass gasket not included)
10300	Handle Assembly
11530	Hinge, Pin Short (Requires Welding) - Requires 2
10362	Torque Plate (latch)
	Draft Module Parts
26M28	Module Assembly, Draft (flame height control)
	Firebox Parts (see firebrick diagram, page 20) note: all firebrick are 1 1/4" thick
12020	Front, Air Tube Assembly (includes brick retainer)
12030	Rear, Air Tube Assembly (includes brick retainer)
FB-1	Firebrick, 9 x 4 1/2"
FB-2	Firebrick, 9 x 4 1/2" w/notch
10545	Firebrick, 9 x 4 1/2" w/notch (baffle brick are a special denser brick. Do not substitute with FB-2)
FB11	Firebrick, 4 1/2 x 4 3/8"
FB5	Firebrick, 9 x 2 1/2" w/hole
	Fan System Parts (if optional kit(s) installed)
14440	Dial - A - Temp (rheostat)
	Misc. Component Parts
775000M	Installation / Operation Manual

For the location of the nearest Dealer for replacement parts, contact:

**Lennox Hearth Products
1110 West Taft Avenue
Orange, CA 92865**

REPLACEMENT PARTS – Model 1400HT

FIREBRICK DIAGRAM

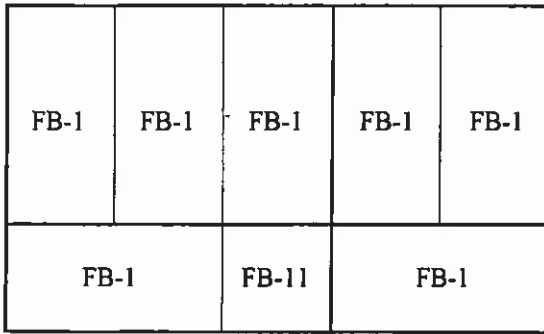

BOTTOM

Must Chip Approx.
1" x 1" Notches

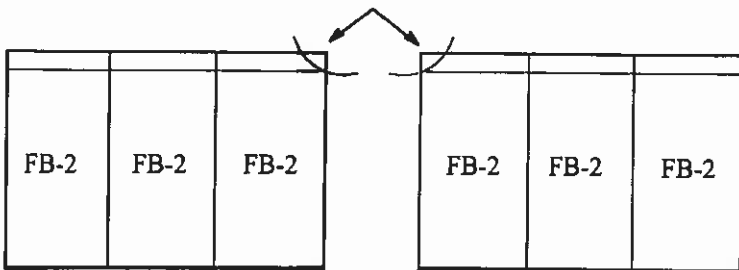

LEFT

RIGHT

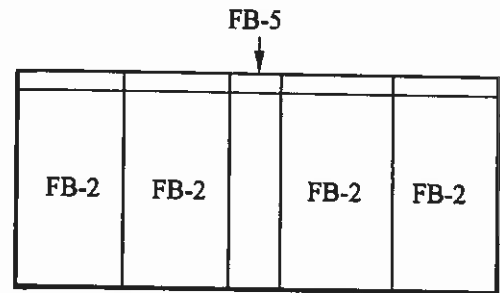

BACK

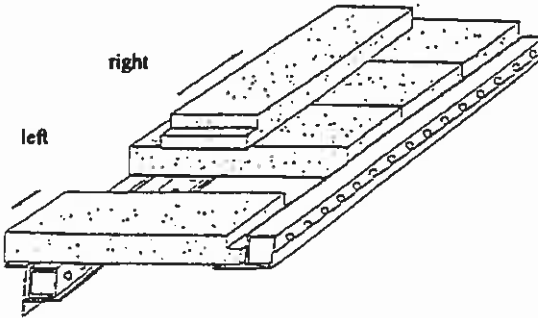

Baffle Brick - p/n 10545 (5 ea)

DOOR ASSEMBLY

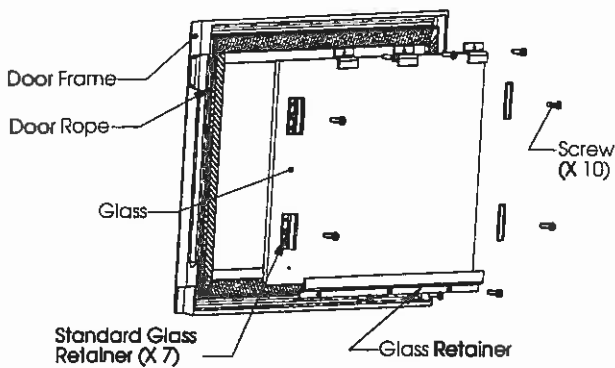

HANDLE ASSEMBLY

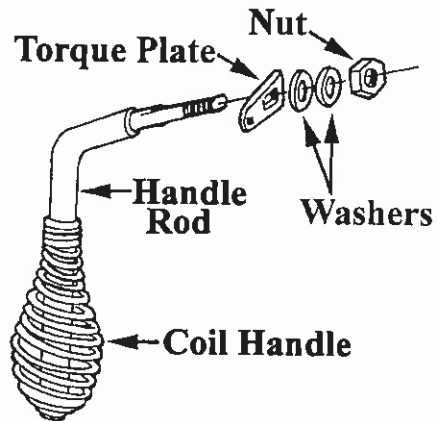

OPTIONAL ACCESSORIES – Model 1400HT

Note: Install and use accessories per instructions provided with the accessory kit.

Catalog #	Description(Model)	Notes
14M66	Outside Air Floor Duct (OAFD-R)	3" Diameter Round
14M22	Blower Kit (BK-100)	Includes Dial-A-Temp for Variable Speed Control
14M21	Stove Stat Kit (SSK)	Thermally Controls Blower
70K99	Touch-up Spray Paint Kit, Black (TSPK-B)	12 oz Spray Can

Outside Air Floor Duct (OAFD-R)

Outside air can be delivered for combustion air by utilizing this floor penetration duct.

(Duct penetration measures 3" [76 mm] diameter round)

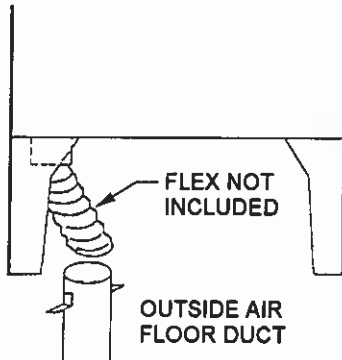

Blower Kit (BK-100)

A Blower Kit (includes rheostat for variable speed control) is available for increased heat circulation.

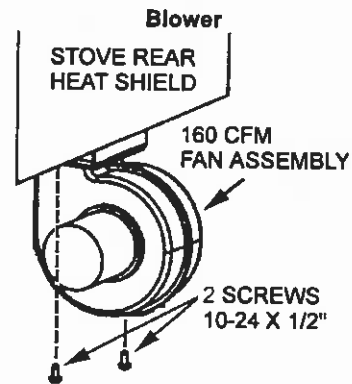

Variable Speed Control, Dial-A-Temp

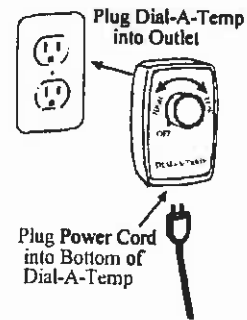

Stove-Stat Kit (SSK)

To automate the blower system an additional Stove-Stat kit can be purchased. The Stove-Stat is a heat sensor switch that will automatically turn on the blower when the stove is hot and automatically turn it off when the stove is cool.

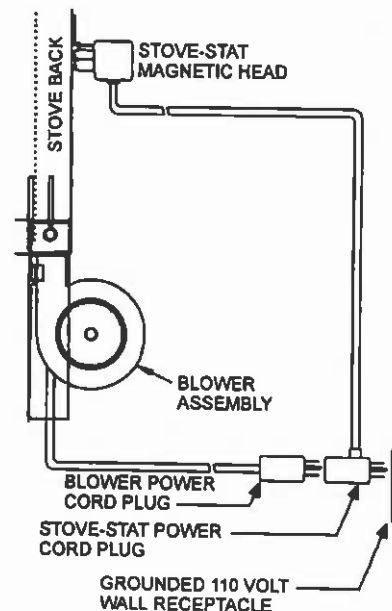

SAFETY/LISTING LABEL

CONTACT YOUR LOCAL BUILDING OR FIRE OFFICIALS ABOUT RESTRICTIONS AND INSTALLATION INSPECTION IN YOUR AREA
CONTACTEZ LE BUREAU DE LA CONSTRUCTION OU LE BUREAU DES INCENDIES AU SUJET DES RESTRICTIONS ET DES INSPECTIONS D'INSTALLATION DANS VOTRE VOISINAGE

Listed Room Heater, Solid Fuel Type. Listed Fireplace Accessory/Insert Also Suitable for Manufactured (Mobile) Home Installation Permitted to (UM)84-HUD
 Appareil de chauffage de pièce, de combustibles solides. enregistré pour usage avec accessoires pour foyer inséré, pour usage dans les maisons mobiles selon les codes d'installation (UM)84-HUD
 FOR USE WITH SOLID WOOD FUEL ONLY / POUR USAGE AVEC LE BOIS SEULEMENT.



MODEL / MODÈLE: 1400 HT/1500 HT
SERIAL NO. / NUMÉRO DE SÉRIE

Manufactured by / Manufacturé par:
LENNOX HEARTH PRODUCTS
 1110 West Tait Avenue
 Orange, CA 92665



"PREVENT HOUSE FIRES"

Install and use only in accordance with manufacturer's installation and operating instructions and your local building codes.

CAUTION: Special methods are required when passing chimney through a wall or ceiling, refer to local building codes. Do not pass chimney connector through a combustible surface. Do not connect this unit to a chimney flue serving another appliance.

WARNING: (MOBILE HOME) An outside air Inlet must be provided for combustion and be unrestricted while unit is in use. Do not install appliance in a sleeping room. The structural integrity of the mobile home floor, walls and ceiling/roof must be maintained. Not approved for mobile home in Canada.

TESTED TO: UL 1482, ULC S-627

DESIGN NO: ES-22

Electrical Rating: 115 VAC .9 Amps 60 Hz

Optional Kit #14M22 on Freestanding.

DANGER: Risk of electrical shock. Disconnect power before servicing unit. Do not route power cord under or in front of appliance.

NOTE: Replace glass only with 5mm ceramic.

"PRÉVENTION DES FEUX DE MAISON"

Installez et utilisez en accord avec les instructions d'installation et d'opération du fabricant et des codes locaux.

AVIS: Prenez des précautions spéciales lorsque vous faites passer une cheminée à travers un mur ou un plafond, référez-vous aux codes locaux de la construction. Ne pas faire passer le tuyau de cheminée à travers une surface combustible. Ne pas connecter cet appareil à un tuyau de cheminée servant un autre appareil.

ATTENTION: (MAISON MOBILE) Un tuyau d'air extérieur doit être fourni pour la combustion et ne doit pas être restrictif pendant l'usage. Ne pas installer cet appareil dans une chambre à coucher. L'intégrité de la structure du plancher, des murs et des plafonds/toits doit être maintenue. Cet appareil n'est pas approuvé pour les maisons mobiles au Canada.

TESTÉ À: UL 1482, ULC S-627

NUMÉRO DE CRÉATION: ES-22

Puissance Électrique: 115 VAC .9 Amps 60 Hz

Matériel Optionnel: #14M22 sur pieds

DANGER: Il y a risque de décharge électrique. Déconnectez le fil électrique de la prise de contact avant le service. Ne pas faire passer le fil électrique sous ou en avant de l'appareil.

NOTE: Remplacez la vitre avec une céramique de 5mm aulement.

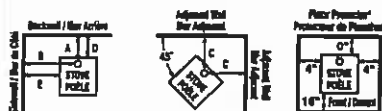

Floor protector must be non-combustible material, extending beneath heater end to the front/sides/rear as indicated. Le protecteur de plancher doit être de matériel incombustible, s'étendant en dessous de l'appareil de chauffage et de l'avant/des côtés/et de l'arrière comme indiqué.

*In Canada, required floor protection must be 18" (450mm) in front and 8" (200mm) on all other sides of the appliance. *Au Canada, la protection du plancher doit s'étendre de 18" (450mm) en avant et de 8" (200mm) sur tous les autres côtés de l'appareil.

Minimum Clearances to Combustible Materials (In Inches) / Espaces Libres Minimum Aux Combustibles (en pouces)

Installation	Clearance Espaces Libres	Chimney & Connector Cheminée et Tuyau	Dimensions					
			A	B	C	D	E	F
Residential / Résidentielle	Standard	Note: 1	15.0	19.0	15.0	13.0	8.5	5.0
Residential / Résidentielle	Reduced / Réduits	Note: 2	10.5	20.0	15.0	8.0	9.5	5.0
Mobile Home / Maison Mobile	Standard	Note: 2	10.5	20.0	15.0	8.0	9.5	5.0
Alcove / Alcôve	Standard	Note: 2,3	10.5	20.0	N/A	8.0	9.5	N/A

Note 1: 6 inch diameter, single wall, minimum 25 MSG black or 25 MSG blue steel connector pipe with a listed factory-built UL103 HT (In Canada, ULC S629 [650°C]) chimney suitable for use with solid fuels or masonry chimney.

Note 1: Le tuyau connecteur en acier bleu ou noir de minimum 25 MSG, de 6" de diamètre, mur simple, avec cheminée faite en usine, enregistrée sous UL-103HT (au Canada, ULC S629 [650°C]) pour usage avec les combustibles solides ou une cheminée de briques approuvée.

Note 2: 6 inch diameter, L-Vent (See manual for Mobile Home) Insulated connector pipe with listed factory-built Class "A" chimney or a masonry chimney. (Mobile Home must be equipped with a spark arrester).

Note 2: Le tuyau connecteur isolé, L-Vent (référez-vous au manuel d'installation du propriétaire), de 6" de diamètre, avec cheminée faite en usine de Classe A ou cheminée en briques. (Les maisons mobiles doivent être équipées avec d'un arrêt d'étincelles).

Note 3: Alcove Dimensions: 7' high min., 48" wide min. with 48" depth max.

Note 3: Les dimensions de l'alcôve sont de 7' d'hauteur minimum, 48" de largeur minimum, avec 48" de profondeur maximum.

CAUTION: HOT WHILE IN OPERATION. DO NOT TOUCH. CONTACT MAY CAUSE SKIN BURNS. KEEP CHILDREN, CLOTHING, FURNISHINGS AND COMBUSTIBLE MATERIAL A CONSIDERABLE DISTANCE AWAY. SEE NAMEPLATE AND INSTRUCTIONS. DO NOT OVERFIRE. IF HEATER OR CHIMNEY CONNECTOR GLOWS, YOU ARE OVERFIRING. INSPECT AND CLEAN CHIMNEY AND CONNECTOR FREQUENTLY. UNDER CERTAIN CONDITIONS OF USE, CREOSOTE BUILDUP MAY OCCUR RAPIDLY. DO NOT USE GRATE OR ELEVATE FIRE - BUILD WOOD FIRE DIRECTLY ON HEARTH. DO NOT BURN WITH FEED DOOR OPEN. FEED DOOR MUST BE CLOSED DURING FIRING EXCEPT WHEN ADDING FUEL. OPEN COMBUSTION AIR CONTROL BEFORE OPENING FEED DOOR.



ATTENTION: CHAUD LORS DE L'OPÉRATION. NE PAS TOUCHER. LE CONTACT PEUT CAUSER DES BRÛLURES À LA PEAU. GARDEZ LES ENFANTS, LES VÊTEMENTS, LES MEUBLES ET LES MATÉRIAUX COMBUSTIBLES LOIN DE L'ESPACE DESIGNÉ DE L'APPAREIL. VOIR L'ÉTIQUETTE ET LES INSTRUCTIONS. NE PAS SURCHAUFFER. SI L'APPAREIL DE CHAUFFAGE OU LE TUYAU DE CHEMINÉE ROUGISSENT, VOUS SURCHAUFFEZ. INSPECTEZ ET NETTOYEZ LA CHEMINÉE ET LE TUYAU CONNECTEUR FREQUENTEMENT. SOUS CERTAINES CONDITIONS, IL SE PEUT QUE LA CRÉOSOTE S'ACCUMULE RAPIDEMENT. N'ÉLEVEZ PAS LE FEU. BÂTISSEZ LE FEU DE BOIS DIRECTEMENT SUR L'ÂTRE. NE PAS BRÛLER LORSQUE LA PORTE D'OUVERTURE EST OUVERTE. LA PORTE D'OUVERTURE DOIT ÊTRE FERMÉE PENDANT L'USAGE EXCEPTÉ PENDANT QUE VOUS AJOUTEZ DU FEU. OUVREZ LE TUYAU D'AIR AVANT D'OUVRIR LA PORTE D'OUVERTURE.

U.S. ENVIRONMENTAL PROTECTION AGENCY
 Certified to comply with July 1990 particulate emission standards.

Date of Manufacture / Date de Fabrication
 2002 2003 2004 Jan. Feb. Mar. Apr. May June July Aug. Sept. Oct. Nov. Dec.

DO NOT REMOVE THIS LABEL / NE PAS ENLEVER CETTE ÉTIQUETTE

Made in U.S.A. / Fait aux États-Unis

PN 12096
 REV. C

EPA LABEL

Manufactured by: Lennox Hearth Products Model: 1400 MT/1500 HT/2500 MT

US ENVIRONMENTAL PROTECTION AGENCY

MEETS EPA PARTICULATE MATTER (SMOKE) CONTROL REQUIREMENTS FOR
NONCATALYTIC WOOD HEATERS BUILT ON OR AFTER JULY 1, 1990.

SMOKE

THIS MODEL

0 (Grams Per Hour) 8.5

EFFICIENCY

50% 60% 70% 80% 90% 100%

Wood heaters with higher efficiencies cost less to operate.
*(NOT TESTED FOR EFFICIENCY. THE VALUE INDICATED IS FOR SIMILAR
NONCATALYTIC WOOD HEATERS.)

HEAT OUTPUT
11,700 to 37,000 Btu/Hr

Use this to choose the right size appliance for your needs.
ASK DEALER FOR HELP

This wood heater will achieve low smoke output and high efficiency only if properly
operated and maintained. See owner's manual.

LENNOX[®]

HEARTH PRODUCTS

1110 West Taft Avenue

Orange, CA 92865

Herrera, Judy

From: Roberts, Francine
Sent: Thursday, April 04, 2002 8:50 AM
To: Herrera, Judy
Subject: Claim Forms

Judy,

Could you please send me a couple packs of claim forms? Thanks.

Thank you,

Francine V. Roberts

Warranty Tech

Lennox Hearth Products

Phone: (360) 757-5833 or (800) 299-0027 Ext. 833

Fax: (360) 757-9720

E-Mail: Francine.Roberts@LennoxHP.com

Herrera, Judy

From: Roberts, Francine
Sent: Thursday, April 04, 2002 8:50 AM
To: Herrera, Judy
Subject: Claim Forms

Judy,

Could you please send me a couple packs of claim forms? Thanks.

Thank you,

Francine V. Roberts

Warranty Tech

Lennox Hearth Products

Phone: (360) 757-5833 or (800) 299-0027 Ext. 833

Fax: (360) 757-9720

E-Mail: Francine.Roberts@LennoxHP.com

