

**CJW1000, CJW1500, CJW2000 SERIES
HIGH EFFICIENCY AIR TIGHT WOOD STOVE**

For Residential Installation

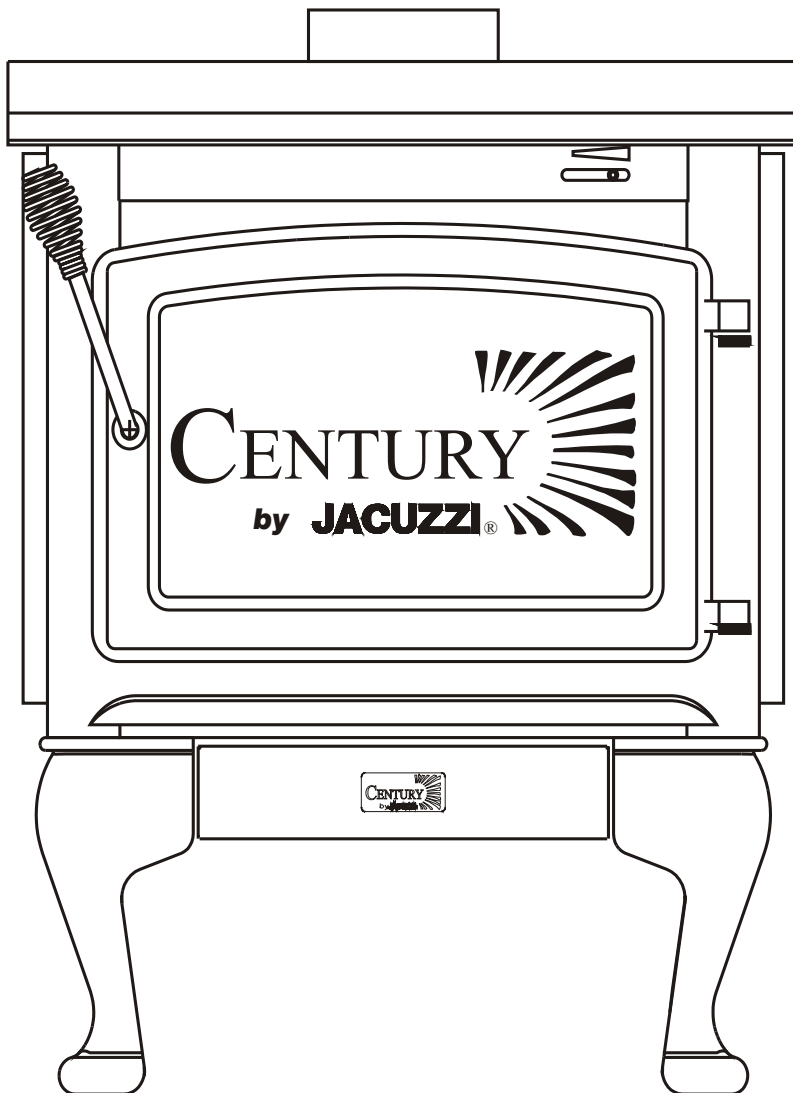

6" (152mm) FLUE REQUIRED



SAVE THIS MANUAL FOR FUTURE REFERENCE

SAFETY NOTICE

Read this entire manual before you install and use your Appliance.

If not properly installed, a house fire may result.

To reduce the risk of fire, follow the installation instructions.

Failure to follow instructions may result in property damage, bodily injury, or even death.

Contact local building, fire officials or authorities having jurisdiction about permits, restrictions and installation

inspection requirements in your area.

This unit is not mobile home approved.



TO HELP US HELP YOU]

Fill-in the Information requested below And Retain Proof Of Purchase.

Date Of Purchase

Product Serial Number

Model Number

Model and product serial number can be found on the certification label of your stove.

CAUTION

After reading these instructions if you have any doubt about your ability to complete your installation in a professional like manner you should obtain the services of an installer versed in all aspects as to the correct and safe installation **DO NOT** use temporary makeshift compromises during installation.

BEFORE INSTALLATION OF YOUR APPLIANCE

1. **HOT WHILE IN OPERATION. KEEP CHILDREN, CLOTHING AND FURNITURE AWAY. CONTACT MAY CAUSE SKIN BURNS.**
2. **DO NOT BURN GARBAGE OR FLAMMABLE FLUIDS.**
3. Check with the building inspector's office for compliance with local codes; a permit may be required.
4. This appliance requires a masonry or prefabricated chimney listed to ULC S629 (Canada) and UI103ht (U.S.) Sized correctly.
5. A 6" (152mm) diameter flue is required for proper performance.
6. Always connect this unit to a chimney and **NEVER** vent to another room or inside a building.
7. **DO NOT** connect to any duct work to which another appliance is connected such as a furnace.
8. **DO NOT** connect this unit to a chimney flue serving another appliance.
9. **DO NOT USE CHEMICALS OR FLUIDS TO START THE FIRE.**
10. The connector pipe and chimney should be inspected periodically and cleaned if necessary.
11. Remember the clearance distances when you place furniture or other objects within the area. **DO NOT** store wood, flammable liquids or other combustible materials too close to the unit.
12. Contact your local municipal or provincial fire authority for information on how to handle a chimney fire. Have a clearly understood plan to handle a chimney fire. In the event of a chimney fire, turn air control to closed position and **CALL THE FIRE DEPARTMENT.**
13. **DO NOT** tamper with combustion air control beyond normal adjustment.
14. Once the required draw is obtained, operate only with doors closed and open doors slowly when re-fueling. (This will reduce or eliminate smoke from entering the room).
15. **DO NOT** install these units in a mobile home or trailer. These units are **NOT** mobile home

WHY THE CORRECT FLUE SIZE IS IMPORTANT - 6"(152mm)

Draft is the force, which moves air from the appliance up through the chimney. The amount of draft in your chimney depends on the length of the chimney, local geography, nearby obstructions, and other factors. Too much draft may cause excessive temperatures in the appliance. An uncontrolled burn or a glowing red part or chimney connector indicates excessive draft. Inadequate draft may cause back puffing into the room and "plugging" of the chimney and/or cause the appliance to leak smoke into the room through appliance and chimney connector joints.

Today's solid fuel appliances are much more efficient than in the past. The units are designed to give you controlled combustion, as well as maximum heat transfer, using less fuel to do so.

The design of your new appliance is such that the exhaust "smoke" is now at lower temperatures than in the past, therefore requiring proper chimney size to give adequate draft. If your chimney is too large, the heating appliance will have a difficult time to raise the "chimney flue" temperature to give adequate draft, therefore causing a smoke back up, poor burn, or both.

Should you experience such a problem call in a local chimney expert.

With the door closed, the rate of burning is regulated by the amount of air allowed to enter the unit through the air control. With experience you will be able to set the control for heat and burning time desired.

Attempts to achieve higher output rates that exceed heater design specifications can result in permanent damage to the heater. The recommended wood load is level with the top of the firebricks. Overloading may prevent sufficient air entering the heater to properly fuel the fire.

Do not tamper with combustion air control beyond the normal adjustment capacity.

Operate this heater only with the door closed.

ALWAYS PROVIDE A SOURCE OF FRESH AIR INTO THE ROOM WHERE THE UNIT IS INSTALLED. FAILURE TO DO SO MAY RESULT IN AIR STARVATION OF OTHER FUEL BURNING APPLIANCES AND THE POSSIBLE DEVELOPMENT OF HAZARDOUS CONDITIONS.

THIS HEATER IS EXTREMELY HOT WHILE IN OPERATION. SERIOUS BURNS CAN RESULT FROM CONTACT. CAUTION SHOULD BE OBSERVED ESPECIALLY WHEN CHILDREN ARE PRESENT.

OPTIONAL BLOWER: MODEL S31105
120 VOLTS FREQ 60Hz 0.75AMPS 2900RPM
DANGER: RISK OF ELECTRIC SHOCK. DISCONNECT POWER BEFORE SERVICING UNIT.

IMPORTANT: FOR OPTIMUM HEATER PERFORMANCE AT "LOW" BURN RATE, OPERATE THE FAN AT LOW SPEED.

INSTALLATION

1. Remove all parts from inside the stove body.
2. Select the proper location for the stove. These appliances must not be installed any closer than the minimum clearance to combustible materials shown on page 7 of this manual. The stove must be installed on a non combustible surface as shown on page 7 of this manual.

FAILURE TO FOLLOW THE MINIMUM CLEARANCE REQUIREMENTS MAY RESULT IN AN UNSAFE INSTALLATION.

3. If non combustible materials have been installed on the walls, obtain the minimum clearances from either the manufacture of these materials or the local building inspectors office.
4. Install the refractory bricks (see page 6 of this manual).
5. Install the stovepipe **INSIDE** the flue collar on the top of the stove between the stove and chimney.
6. **DO NOT** use a grate to elevate the fire.

STOVE PIPE

1. A clearance of 18 inch (457mm) between the stovepipe and combustible materials may be required. Check with authorities having jurisdiction in your area.
2. All pipe sections must be connected with the male end (crimped end) toward the stove.
3. Fasten the stove pipe to the flue collar by the use of three sheet metal screws. Do the same at each additional joint to make the entire installation rigid.
4. Maintain the required diameter flue for the entire installation.
5. If you are connecting the stove to an old masonry flue, be sure to have it inspected for cracks and general condition. Resizing with a stainless steel liner may be required.
6. It is recommended that no more than two 90 degree bends be used in the stovepipe installation. More than two 90 degree bends may decrease the amount of draw and possibly cause smoke spillage.
7. A damper is not required in this installation. Remove damper plate in the chimney or secure in the **OPEN** position.
8. Single wall flue pipe assemblies must not exceed 10 feet (3 metres) in overall length.

BRICK DIAGRAMS

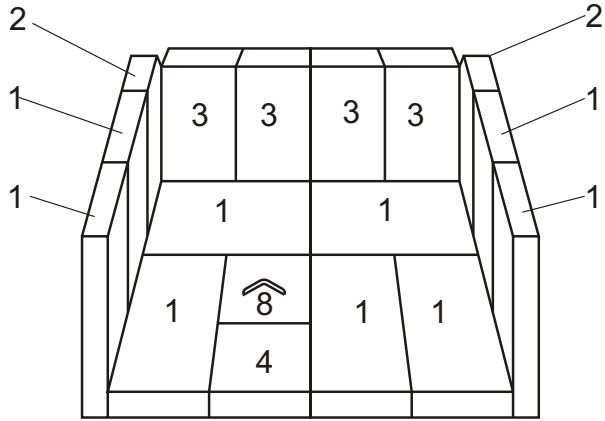

CJW 1000 SERIES

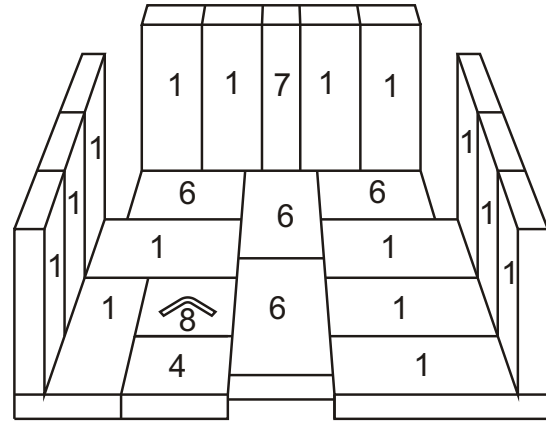

CJW 2000 SERIES

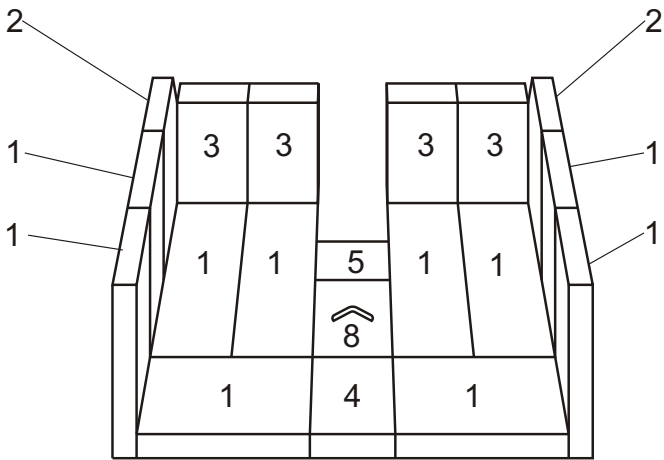

CJW 1500 SERIES

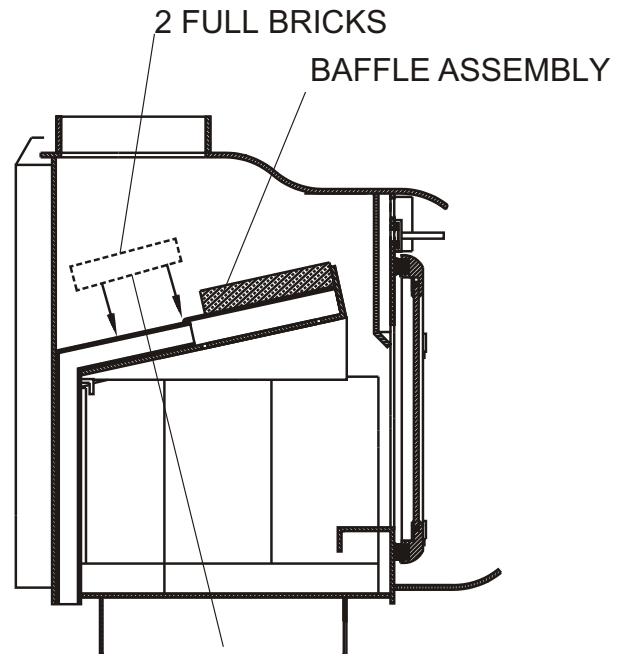

BE SURE TO INSTALL TWO
FULL BRICKS (S16040) IN
BAFFLE AS SHOWN

**BAFFLE BRICK INSTALLATION
CJW 1000 AND CJW 1500 SERIES**

PARTS LIST					
ITEM	DESCRIPTION	PART #	SERIES		
			CJW1000	CJW1500	CJW2000
1	FIREBRICK LT9"(229mm)x4-7/16"(113mm)x1-1/4"(32mm)	S16040	11	12	15
2	FIREBRICK LT-ANGLE CUT	S16042	2	2	
3	FIREBRICK LT7-1/4"(184mm)x4-7/16"(113mm)x1-1/4"(32mm)	S16043	4	4	
4	FIREBRICK LT4-1/2"(114mm)x4-7/16"(113mm)x1-1/4"(32mm)	S16046	1	1	1
5	FIREBRICK LT2-3/4"(70mm)x4-7/16"(113mm)x1-1/4"(32mm)	S16224		1	
6	FIREBRICK LT7-3/4"(197mm)x4-7/16"(113mm)x1-1/4"(32mm)	S16222			4
7	FIREBRICK LT9"(229mm)x2-1/2"(64mm)x1-1/4"(32mm)	S16216			1
8	BRICK FOR ASH DRAWER	S16214	1	1	1

CLEARANCES

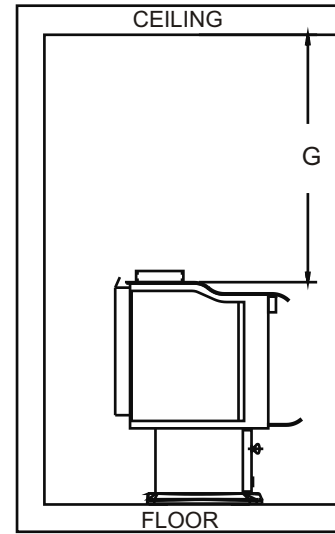
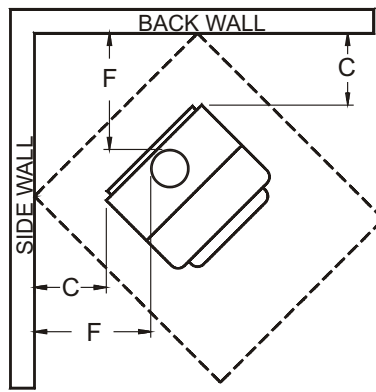
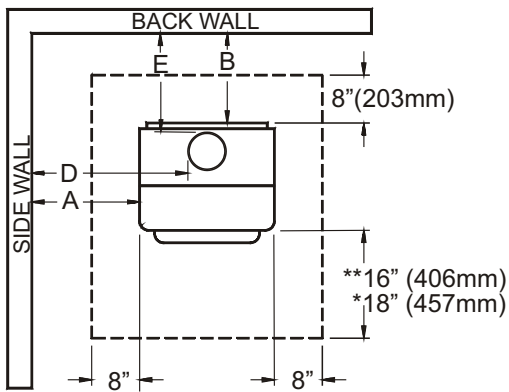

* CANADA **U.S.A

DIMENSIONS: INCHES (mm)

CJW1000 SERIES		CLEARANCE TO COMBUSTIBLES					
	A	B	C	D	E	F	G
WITH SINGLE WALL CONNECTOR	12 (305)	12-1/2 (318)	7 (178)	19-1/2 (495)	15 (381)	15 (381)	56 (1422)
WITH DOUBLE WALL CONNECTOR	8-1/2 (216)	8 (203)	5-1/2 (140)	15-1/2 (394)	10 (254)	13 (330)	56 (1422)
CJW1500 SERIES		CLEARANCE TO COMBUSTIBLES					
	A	B	C	D	E	F	G
WITH SINGLE WALL CONNECTOR	11-1/2 (292)	9 (229)	7 (178)	21 (533)	11-1/2 (292)	18 (457)	54-1/2 (1384)
WITH DOUBLE WALL CONNECTOR	6 (152)	6 (152)	4 (102)	15 (381)	8 (203)	14 (356)	54-1/2 (1384)
CJW2000 SERIES		CLEARANCE TO COMBUSTIBLES					
	A	B	C	D	E	F	G
WITH SINGLE WALL CONNECTOR	15 (381)	10 (254)	9 (229)	24-1/2 (622)	18-1/2 (470)	19-1/2 (495)	54 (1372)
WITH DOUBLE WALL CONNECTOR	14 (356)	10 (254)	8 (203)	23 (584)	15 (381)	18 (457)	54 (1372)

Floor Protector

Installation on a Concrete Floor

An appliance mounted on a concrete floor does not require floor protection.

Carpeting and any other combustible material shall not cover the Floor Protector.

If a combustible surface is applied to the concrete floor, a clearance must be maintained equivalent to the area reserved for the floor protector. See diagram below.

Installation on a Combustible Floor

If the appliance is to be installed on a combustible floor or a combustible floor covering, it must be installed on a 3/8" (10mm) thick non-combustible millboard floor protector or durable equivalent. The pad must be installed beneath the appliance extending 18" (457mm) in Canada, 16" (406mm) in the U.S. on any side equipped with a door, and 8" (203mm) on all other sides. In the U.S. the pad must cover any horizontal chimney connector runs and extend 2" (51mm) beyond each side.

A grouted ceramic floor-tile surface installed per local building code is considered a durable equivalent.

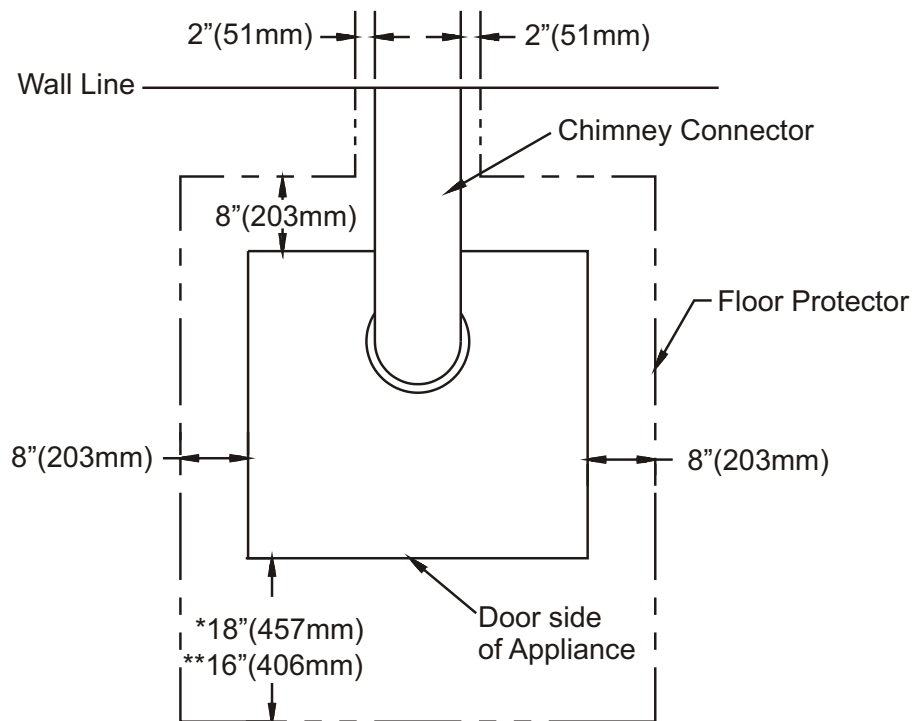

* CANADA

** UNITED STATES

REFER TO CHIMNEY AND CHIMNEY CONNECTOR MANUFACTURER'S INSTRUCTIONS

CHIMNEY

CONTACT YOUR LOCAL BUILDING AUTHORITY FOR APPROVED METHODS OF INSTALLATION

1. This appliance requires a masonry or pre-manufactured chimney listed to ULC S629 (Canada) and UL103HT (USA) sized correctly.
2. If a masonry chimney is used it is advisable to have your chimney inspected for cracks and check the general condition before you install your unit Re-lining may be required to reduce flue diameter to the appropriate functional size.
3. To help ensure a good draft, the top of the chimney should be at least 3 feet (914mm) above the point of penetration through the roof, and be at least 2 (610mm) feet higher than any point of the roof within 10 feet (3M).
4. The chimney connector shall not pass through an attic, roof space, closet, concealed space, floor, ceiling, wall, or any partition of combustible construction.
5. The minimum overall height of your chimney should be 15 feet (5M) from the floor.
6. Do not use makeshift compromises during installation.

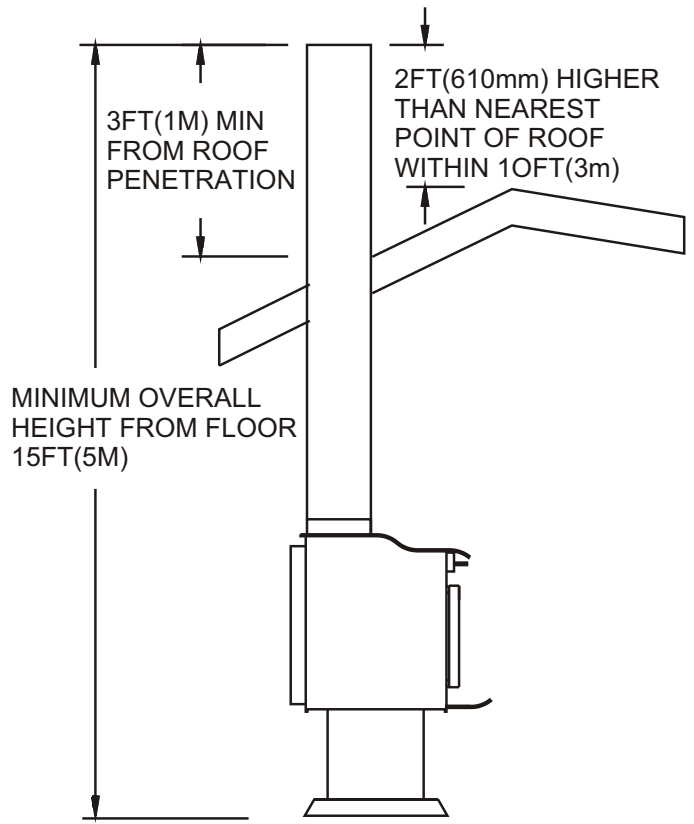

OPERATION

Do not use a grate or elevate fire. Build wood fire directly on hearth. When the stove is used for the first time the solvents in the paint will smoke off.

Wood

This heater is designed to burn natural wood only. Higher efficiencies and lower emissions generally result when burning air dried seasoned hardwoods, as compared to softwoods or to green or freshly cut hardwoods.

Only use dry seasoned wood. Green wood, besides burning at only 60 percent of the fuel value of dry wood, deposits creosote on the inside of your stove and along the chimney. This can cause an extreme danger of chimney fire. To be called "seasoned", wood must be dried for a year. Regardless of whether the wood is green or seasoned, it should be stored in a well-sheltered, ventilated area to allow proper drying during the year to come. Wood should be stored beyond recommended clearance from combustibles.

- DO NOT BURN:** * Treated Wood * Solvents * Trash * Coal
 * Garbage * Cardboard * Coloured Papers

NEVER USE GASOLINE, GASOLINE-TYPE LANTERN FUEL, KEROSENE, CHARCOAL LIGHTER FLUID, OR SIMILAR LIQUIDS TO START OR 'FRESHEN UP' A FIRE IN THIS HEATER. KEEP ALL SUCH LIQUIDS WELL AWAY FROM THE HEATER WHILE IT IS IN USE.

INSTRUCTION FOR FIRST BURN - CURING THE STOVE PAINT

Your stove has been painted with the highest quality stove paint and has special break-in procedures. The heat generated by the normal operation of the stove, will serve to harden the paint.

Ventilate the house during the first three times the stove is used. The paint on the stove will give off smoke, carbon dioxide and an odor. Without adequate ventilation, concentrations of smoke could irritate, or be upsetting. **Open doors and windows and use a fan** if necessary. After the initial burns the paint will be cured and there should be no more smoke.

Each of the initial burns should be conducted as follows:

- A) The 1st 2 burns should be at approximately 250 deg F (120 deg C) for approximately 20 minutes.
- B) The 3rd burn should be between 500 deg F (260 to 370 deg C) for at least 45 minutes. The important fact is the paint should be cured slowly. Avoid hot fires during the curing process.

During the curing process the paint will be gummy. Once cured the paint will remain hard.

It is normal to see flat spots on painted surfaces of the stove. The flat spots on the paint surface indicate the hotter surfaces of the stove, and is caused by the heat radiating through the paint.

It is also expected that shiny spots caused by friction from the packaging materials, will disappear during the curing of the stove.

SO....

- 1) Remember to Ventilate well
- 2) Allow the stove to cure before burning for long periods at high temperatures
- 3) Flat spots on the painted surfaces are normal.
- 4) Shiny spots on the paint surface before burning is normal
- 5) Call your dealer if you have any questions.

BUILDING A FIRE

1. Open inlet air control fully.
2. Place a small amount of crumpled paper in the stove.
3. Cover the paper with a generous amount of kindling in a teepee fashion and a few small pieces of wood.
4. Ignite the paper and close door. If fire dies down substantially, open door slightly.
5. Add larger pieces of wood as the fire progresses being careful not to overload. Do not fill firebox beyond firebrick area. An ideal coal bed of 1" (25mm) to 2" (50mm) should be established to achieve optimum performance.
6. This unit is designed to function most effectively when air is allowed to circulate to all areas of the firebox. An ideal means of achieving this is to rake a slight (1" to 2" wide) trough in the centre of the coal bed from front to back prior to loading the fuel.
7. Once fuel has been loaded, close door and open air inlet control fully until fire is well established (approx. 10 minutes) being careful not to over fire.
8. Re-adjust air inlet control to desired burn rate. If excessive smoke fills firebox, open air inlet control slightly until flames resume and wood is sufficiently ignited. While a basic rule of thumb is "closed - low", "½ way - medium" and "fully open - high". More information is available further in this manual (see page 14 for settings).
9. When refuelling, adjust air control to the fully open position. When fire brightens, slowly and carefully open the door. This procedure will prevent gases from igniting causing smoke and flame spillage.
10. Add fuel being careful not to overload.

GLASS CARE

REPLACE GLASS ONLY WITH HIGH TEMPERATURE ROBAX PYROCERAM OF THE PROPER SIZE AND THICKNESS

The following use and safety tips should be observed:

1. Inspect the glass regularly for cracks and breaks. If you detect a crack or break, extinguish the fire immediately, and contact your dealer for replacement. See page 16 of this manual for replacement parts list.
2. Do not slam door or otherwise impact the glass. When closing doors, make sure that logs or other objects do not protrude to impact the glass.
3. Do not clean the glass with materials which may scratch (or otherwise damage) the glass. Scratches on the glass can develop into cracks or breaks.
4. Never attempt to clean the glass while unit is hot. Light deposits are normal. Heavier deposits may be removed with the use of a readily available oven cleaner.
5. Never put substances which can ignite explosively in the unit since even small explosions in confined areas can blow out the glass.
6. This unit has an air wash system, designed to reduce deposits on glass.

GASKET REPLACEMENT

After extensive use, the sealing material which provides glass and door seal may need to be replaced if it fails to sustain its resilience. Inspect glass and door seal periodically to ensure for proper seal: if gaskets become frayed or worn, replace immediately. Contact your dealer for approved replacement parts. See page 13 of this manual for replacement parts list.

The following steps should be followed for glass gasket replacement:

1. Ensure appliance is not in operation and is thoroughly cooled.
2. Remove screw and glass clips (see page 13 of this manual).
3. Lift glass out.
4. Remove old gasket and clean glass.
5. Replace new gasket starting at the bottom of glass working along edges, being sure to centre gasket channel on glass.
6. Trim to length and butt ends together.
7. Replace glass in door, being sure not to over-tighten screws and clips.

The following steps should be followed for door gasket replacement:

1. Ensure appliance is not in operation and is thoroughly cooled.
2. Remove old door gasket and clean channel.
3. Using an approved high temperature gasket cement, apply a thin coat in bottom of channel.
4. Starting at hinge side of door, work into channel around door unit, end butt and trim to length.
5. Close door and allow three to four hours for cement to set before restarting appliance.

CREOSOTE

When wood is burned slowly, it produces tar and other organic vapours. These combine with moisture to form creosote. Creosote vapours condense in the relatively cool chimney flue of a slow-burning fire. As a result, creosote residue accumulates on the flue lining. When ignited, this creosote makes an extremely hot fire. The chimney should be inspected regularly during the heating season to determine if a creosote build-up has accumulated. If this is the case, the creosote should be removed to reduce the risk of chimney fire.

WARNING: Things to remember in case of chimney fire:

1. CLOSE DRAFT CONTROL. 2. CALL THE FIRE DEPARTMENT.

KEEP UNIT FREE OF CREOSOTE

1. Burn with air control open for several minutes at numerous intervals throughout the day during the heating season, being careful not to over-fire unit. This removes the slight film of creosote accumulated during low burn periods.
2. Burn stove with draft control wide open for several minutes every time you apply fresh wood. This allows wood to achieve the charcoal stage faster and burns wood vapours which might otherwise be deposited within the system.
3. **BURN ONLY SEASONED WOOD.** Avoid burning wet or green wood. Seasoned wood has been dried for at least one year.
4. A small hot fire is preferable to a large smoldering one that can deposit creosote within the system.
5. Establish a routine for the fuel, wood burner and firing technique. Check daily for creosote build-up until experience shows how often you need to clean to be safe. Be aware that the hotter the fire, the less creosote is deposited and weekly cleaning may be necessary in mild weather even though monthly cleaning may be enough in the coldest months. Contact your local municipal authority for information on how to handle a chimney fire. Have a clearly understood plan to handle a chimney fire.

Ash Disposal

This unit features a convenient ash lip for easy removal of ash. During constant use, ashes should be removed every few days, or whenever ashes get to three to four inches deep in the firebox. Remove ashes only when the fire has died down and the ashes have cooled, as in the morning. Even then, expect to find a few hot embers.

Ashes should be placed in a metal container with a tight-fitting lid. The closed container of ashes should be placed on a non-combustible floor or on the ground, well away from all combustible materials, pending final disposal. If the ashes are disposed of by burial in soil or otherwise locally dispersed, they should be retained in the closed container until all cinders have thoroughly cooled. Other waste should not be placed in the ash container.

DOOR REPLACEMENT PARTS

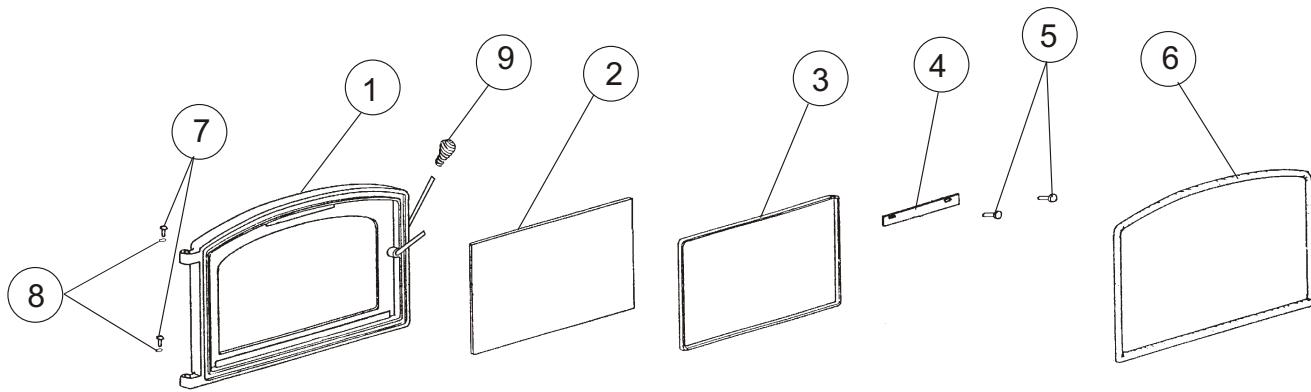

DOOR REPLACEMENT PARTS – CJW1000 SERIES			
ITEM	QTY	DESCRIPTION	PART NO
1	1	DOOR (NO GLASS)	S41105
2&3	1	GLASS AND GASKET	S31117
3	3.5ft (1067mm)	1/8" (3mm) GLASS GASKET ONLY	S15001
4	1	GLASS CLIP	S37018
5	2	SCREW	S11086
6	4.3FT (1311 mm)	5/8" (16mm) DOOR GASKET ONLY	S15011
7	2	HINGE PIN GOLD	S11066
8	2	SPRING NUT	S11090
9	1	SPRING HANDLE	S11007

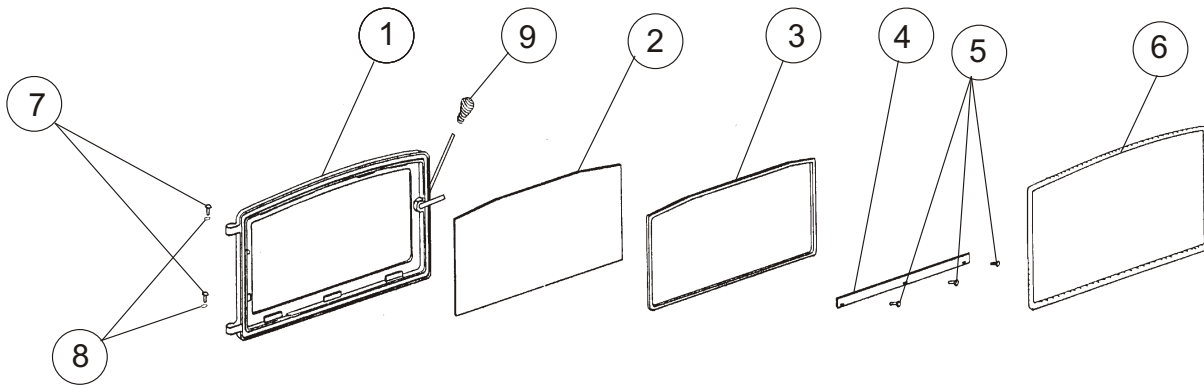

DOOR REPLACEMENT PARTS CJW15000, CJW2000 SERIES			
ITEM	QTY	DESCRIPTION	PART NO
1	1	DOOR (NO GLASS)	S41164
2&3	1	GLASS AND GASKET	S31141
3	4.3ft (1311mm)	1/8" (3mm) GLASS GASKET ONLY	S15001
4	1	GLASS CLIP	S37026
5	3	SCREW	S11086
6	5FT (1524 mm)	5/8" (16mm) DOOR GASKET ONLY	S15011
7	2	HINGE PIN GOLD	S11066
8	2	SPRING NUT	S11090
9	1	SPRING HANDLE	S11007

SPRING HANDLE ASSEMBLY

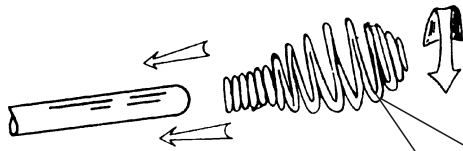

Door Spring Handle
P/N S11007
Air Control- Spring Handle
P/N S11008

Spring Handle

Twist spring handle in a counter clockwise motion while pushing on the handle will "thread" down to desired location

Brass Body Trim
P/N S32217- CJW1000 series
P/N S32098- CJW1500 series
P/N S32592- CJW2000 series

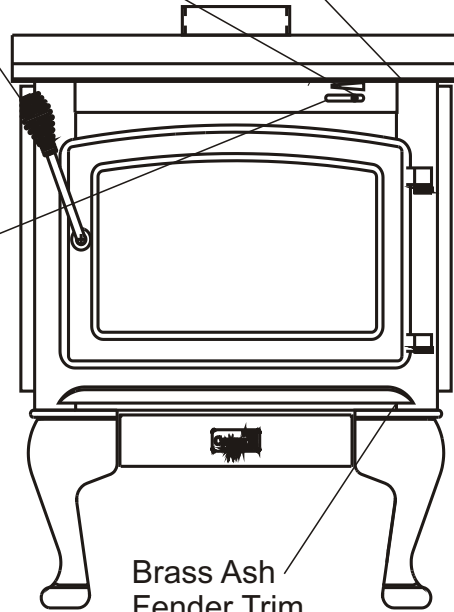
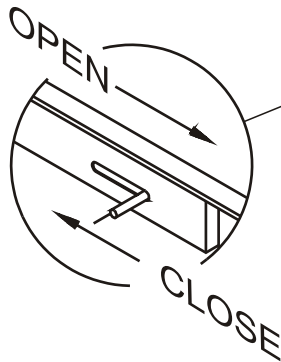

Brass Ash
Fender Trim
P/N S32023- CJW1000 series
P/N S32075- CJW1500 series
P/N S32593- CJW2000 series

Decorative Brass trim

Remove protective plastic coating from Decorative Brass Trim before operating your wood heater.

AIR CONTROL SETTINGS

Model Series	Desired Burn Rate	Inlet Air Setting	**Approximate BTU Output
CJW1000	Low	Fully closed	10,467
	Medium Low	1/4" (6mm) open	12,118
	Medium High	1/2" (13mm) open	19,413
	High	Fully open	26,100
CJW1500	Low	Fully closed	10,370
	Medium Low	1/8" (3mm) open	12,420
	Medium High	1-3/8" (35mm) open	15,676
	High	Fully open	29,301
CJW2000	Low	Fully closed	12,000
	Medium Low	1/8" (3mm) open	13,400
	Medium High	1/4" (6mm) open	17,700
	High	Fully open	55,100

** Performance may vary depending on actual home operating conditions.

IMPORTANT

HELPFUL HINTS WORTH REPEATING

1) What is the correct way to start a fire?

- a.) You will need small pieces of dry wood (kindling) and paper. Use only newspaper or paper that has not been coated or had unknown materials glued or applied to it. **Never** use coated (typically advertising flyers) or coloured paper.
- b.) Open the door of the wood stove.
- c.) Crumple several pieces of paper and place them in the centre of the firebox and directly on to the firebricks of the wood stove (see page 6 of this manual). **Never** use a grate to elevate the fire.
- d.) Place small pieces of dry wood (kindling) over the paper in a "Teepee" manner. This allows for good air circulation, which is critical for good combustion.
- e.) Light the crumpled paper in 2 or 3 locations. *Note: It is important to heat the air in the stovepipe for draft to start.*
- f.) Fully open the air control of the wood stove (see page 14 of this manual) and close the door until it is slightly open, allowing for much needed air to be introduced into the fire box. Never leave the door fully open as sparks from the kindling may occur causing injury. As the fire begins to burn the kindling, some additional kindling may be needed to sustain the fire. **DO NOT** add more paper after the fire has started.
- g.) Once the kindling has started to burn, start by adding some of your smaller pieces of seasoned (dry) firewood. *Note: Adding large pieces at the early stages will only serve to smother the fire.* Continue adding small pieces of seasoned (dry) firewood, keeping the door slightly open until each piece starts to ignite. Remember to always open the door slowly between placing wood into the fire.
- h.) Once the wood has started to ignite and the smoke has reduced, close the wood stove door fully. The reduction of smoke, is a good indication that the draft in the chimney has started and good combustion is now possible. Larger pieces of seasoned (dry) firewood can now be added when there is sufficient space in the firebox. Adjust the air control setting to desired setting (see page 14)
- i.) Note: The lower the air control setting the longer the burn time of your firewood.

2) What type of wood is best to use as Firewood?

Dry seasoned hardwood should be used. Avoid green unseasoned wood. Green wood, besides burning at only 60 percent of the fuel value of dry seasoned wood, will deposit creosote on the inside of your stove and along the inside of your chimney.

3) What does dry seasoned wood mean, and what is considered hardwood?

Wood that has been dried for a period of one year in a well-ventilated and sheltered area would be considered dry seasoned wood. Hardwoods are generally from slow growth trees (*Example: Oak and Fir*). Softwoods are generally from fast growth trees. (*Example: Pine and Spruce*)

HELPFUL HINTS WORTH REPEATING

continued

4.) Will following the above listed steps for starting a fire result in perfect results all the time?

The quick answer is most of the time. There are many variables that may affect your success rate when starting a fire. Most of those variables and how to deal with them will be learned through experience. Your ability to start a good fire will significantly increase with time and patience. Some of the reasons for poor stove performance will be covered in the next section of these instructions.

5.) Why can't I get the fire lit?

Damp or wet wood and poor draft are the main reasons for poor results in starting a fire. Always use dry seasoned wood for your fire. Even wood dried for two years will be difficult to ignite, if it has become wet.

6.) Why is there always a large quantity of thick black smoke present in the firebox?

A large quantity of thick black smoke in the firebox, is a good indication that the draft is poor.

7.) Is it normal for soot to cover the glass at the beginning of a fire?

Your stove has been built with an air wash system that will help keep the glass clear when the firebox has reached a good operating temperature, and has a good draft. Cold firebox temperature and poor draft cause sooting of the glass. Once the firebox temperature and the draft increases, the soot will burn off.

8.) What is draft?

Draft is the ability of the chimney to exhaust draw by-products produced during the normal combustion process.

9.) What can cause a poor draft?

The most common factors for poor draft are:

- a.) Atmospheric pressure and air supply
- b.) Environmental conditions
- c.) Cold chimney temperature
- D.) Poor chimney installation and maintenance

HELPFUL HINTS WORTH REPEATING

continued

a.) Atmospheric Pressure and Air Supply

Atmospheric pressure affecting the draft from a chimney can be either outside the home, inside the home or both. Outside the home, a high-pressure day (clear and cool) generally creates a better draft in the chimney than a low-pressure day (overcast and damp). Inside the home, normal household appliances, such as clothes dryers and forced air furnaces compete for air resulting in inadequate amounts of air available to fuel a fire and create a condition known as negative pressure. Under extreme conditions of negative pressure the combustion by-products can be drawn from the chimney and into the house. This condition is commonly referred to as down drafting.

There are several factors that impact the amount of air available in the home. Increased amounts of insulation vinyl windows, extra caulking in various places and door seals can all keep heat in but may also make a home too airtight. If you are in doubt about whether or not there is sufficient air in your home for your stove, curtail from using those appliances known to consume the air where possible, or open a window or door to allow air to enter the home.

b.) Environmental Conditions

High trees, low lying house location such as in a valley, tall buildings or structures surrounding your house and windy conditions can cause pool draft or down drafting.

c.) Cold Chimney Temperature

Avoid cold chimney temperatures by burning a hot fire for the first fifteen to forty minutes, being careful not to over fire. If any part of the chimney or parts of the stove start to glow, you are over firing the stove. Where possible, install a temperature gauge on the chimney so temperature drops can be seen.

d.) Chimney Installation and Maintenance

Avoid using too many elbows or long horizontal runs. If in doubt, contact a chimney expert and/or chimney manufacturer for help. Clean chimney, rain caps and especially spark arrester regularly, to prevent creosote build-up, which will significantly reduce chimney draw and possibly a chimney fire.

10.) Should I close or open the air control fully when shutting down the stove?

When shutting down the stove, fully open the air control. This allows the chimney temperatures to remain as high as possible for as long as possible. Cold chimney temperatures create creosote.

Note: This sheet is intended as an aid and does not supercede any local, provincial or state requirements. Check with officials or authorities having jurisdiction in your area.

Manufactured by:

Jacuzzi Leisure Products Inc., 330 Humberline Drive, Toronto, Ontario, Canada, M9W-1R5