

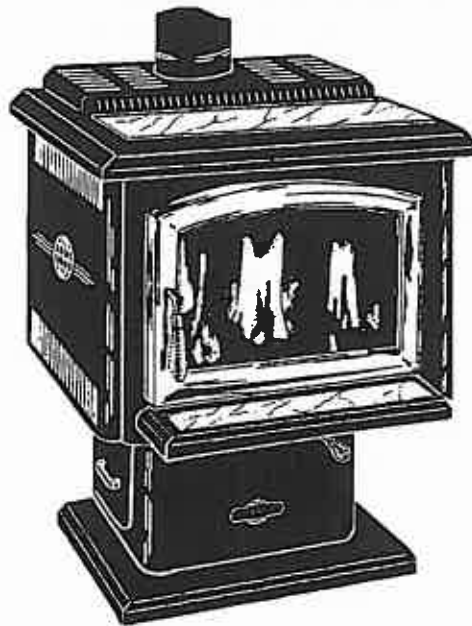

INSTALLATION AND OPERATION MANUAL

**EPA CERTIFIED
NONCATALYTIC
FREESTANDING
WOODSTOVE**



RETAIN THESE
INSTRUCTIONS
FOR FUTURE
REFERENCE

MODEL 1900HT-M

THIS APPLIANCE MUST BE INSTALLED BY A QUALIFIED TECHNICIAN.
READ MANUAL THOROUGHLY BEFORE INSTALLATION.



P/N 775002M, Rev. E, 04/02

IMPORTANT WARNINGS

CAUTION: PLEASE READ THIS ENTIRE MANUAL BEFORE YOU INSTALL AND USE YOUR NEW ROOM HEATER. FOR YOUR SAFETY, FOLLOW THE INSTALLATION, OPERATION AND MAINTENANCE INSTRUCTIONS EXACTLY, WITHOUT DEVIATION. FAILURE TO FOLLOW THESE INSTRUCTIONS MAY RESULT IN PROPERTY DAMAGE, BODILY INJURY, OR EVEN DEATH. IF THIS APPLIANCE IS NOT PROPERLY INSTALLED, A HOUSE FIRE MAY RESULT. CONTACT YOUR LOCAL BUILDING OR FIRE OFFICIALS ABOUT RESTRICTIONS AND INSTALLATION INSPECTION REQUIREMENTS IN YOUR AREA.

1. If utilizing an older chimney, it must be inspected for adequate serviceability. Refer to the heading *Chimney Inspection* on page 9 of this manual.
2. The minimum clearances must be maintained for all combustible surfaces and materials including; furniture, carpet, drapes, clothing, wood, papers, etc. Do not store firewood within this clearance space. Failure to maintain clearances to all combustibles may result in a house fire.
3. This appliance requires non-combustible floor protection as outlined in this manual (see *Floor Protection* on page 5 for additional information).
4. Minimum ceiling height must be 7 feet (213 cm) (measured from base of appliance to ceiling).
5. **DO NOT CONNECT THIS UNIT TO A CHIMNEY FLUE CONNECTED TO ANOTHER APPLIANCE.**
6. Do not connect this appliance to air ducts or any air distribution system.
7. **PREVENT CREOSOTE FIRE:** Inspect and clean chimney frequently. Under certain conditions of use, creosote buildup may occur rapidly. Inspect chimney connector and chimney twice monthly and clean if necessary. Using green or inadequately seasoned wood can greatly increase creosote buildup. Use dry wood to minimize creosote buildup.
8. **USE SOLID WOOD FUEL ONLY:** This appliance is approved for burning dry seasoned natural wood only. **CAUTION: BURN UNTREATED WOOD ONLY. DO NOT BURN GARBAGE OR FLAMMABLE FLUIDS SUCH AS GASOLINE, NAPHTHA OR ENGINE OIL.**
9. Never use gasoline, gasoline-type lantern fuel, kerosene, charcoal lighter fluid, or similar liquids to start or "freshen up" a fire in this heater. Keep all such liquids well away from the heater while it is in use.
10. **DO NOT OVERFIRE:** If heater or chimney connector glows, you are overfiring. Overfiring this appliance could cause a house fire. Overfiring is a condition where the appliance is operated at temperatures above its design capabilities. Overfiring can be caused by improper installation, improper operation, lack of maintenance or improper fuel usage. Damage caused from overfiring is NOT covered under the manufacturer's limited warranty.
11. **NEVER LEAVE AN UNATTENDED STOVE BURNING ON HIGH.** Operation of the stove with the primary air control at its highest burn rate setting for extended periods can cause dangerous overfiring conditions. The primary air control should only be positioned at the highest setting during start-up procedures and for short durations. When leaving the stove unattended ensure that the primary air control is set to the low or medium low range.
12. Use a metal container with a tight fitting lid to dispose of ashes.
13. **IN THE EVENT OF A COMPONENT FAILURE, USE ONLY COMPONENTS PROVIDED BY THE MANUFACTURER AS REPLACEMENT PARTS.**
14. Burning any kind of fuel uses oxygen from the dwelling. Be sure that you allow an adequate source of fresh air into the room where the stove is operating (see *Ventilation and Outside Combustion Air*, page 7).
15. **CAUTION: HOT WHILE IN OPERATION.** An appliance hot enough to warm your home can severely burn anyone touching it. Keep children, clothing and furniture away. Contact may cause skin burns. Do not let children touch the appliance. Train them to stay a safe distance from the unit.
16. Do not operate this appliance without the firebox baffle brick properly installed.
17. Build fires directly upon the brick hearth inside the stove. Do not use grates, irons or any other method to elevate the fire.
18. **SAVE THESE INSTRUCTIONS.**
19. See the listing label located on the back of stove (or see Safety/Listing Label on page 24).

TABLE OF CONTENTS

| | |
|---|-------|
| Important Warnings | 2 |
| Testing/Listing, EPA, Using this Manual | 3 |
| Planning Your Installation | 4-6 |
| Manufactured (Mobile) Home Requirements | 7 |
| Installation | 7-12 |
| Product Features and Controls | 13 |
| Care and Operation | 13-16 |
| Recommended Fuel | 16 |
| Maintenance | 17-18 |
| Troubleshooting | 19 |
| Replacement Parts List | 20-21 |
| Optional Accessories | 22 |
| Specifications | 23 |
| Safety/Listing Label | 24 |
| EPA Label | 25 |
| Ownership Records | 26 |

TESTING/LISTING

Model 1900HT-M has been Safety tested to U. L. Standards #1482, 5th Edition; ULC-S627 by OMNI Environmental Services, Inc.; Beaverton, OR; Report Number #030-S-03-2.

EPA CERTIFICATION

This heater meets EPA particulate matter (smoke) control requirements for noncatalytic wood heaters built on or after July 1, 1990.

PACKAGING LIST

This appliance is packaged with an accessory package, which contains the following:

- One - Installation and operation instructions manual.
- One - Warranty.
- One - Marble set (for stove top and ash lip).
- One - Insulation pad and strips. Place pad and strips under top marble.

USING THIS MANUAL

Please read and carefully follow all of the instructions found in this manual. Please pay special attention to the safety instructions provided in this manual. The Homeowner's Care and Operation Instructions included here will assure you have many years of dependable and enjoyable service from your appliance.

CONGRATULATIONS ON THE PURCHASE OF YOUR NEW WOODSTOVE MANUFACTURED BY LENNOX HEARTH PRODUCTS.

When you purchased your new woodstove, you joined the ranks of thousands of concerned individuals whose answer to their home heating needs reflects their concern for aesthetics, efficiency and our environment. We extend our continued support to help you achieve the maximum benefit and enjoyment available from your new wood stove.

It is our goal at Lennox Hearth Products to provide you, our valued customer, with an appliance that will ensure you years of trouble free warmth and pleasure.

Thank you for selecting a Lennox Hearth Products stove as the answer to your home heating needs.

Sincerely,
All of us at Lennox Hearth Products

PLANNING YOUR INSTALLATION

QUESTIONS TO ASK LOCAL BUILDING OFFICIAL

A correct installation is critical and imperative for reducing fire hazards and perilous conditions that can arise when wood burning appliances are improperly installed. The installer must follow all of the manufacturers' instructions.

The installation of a wood burning appliance must conform to local codes and applicable state and federal requirements. Familiarity with these requirements before installation is essential. Important considerations to discuss with local building officials include:

1. Applicable codes (i.e. Uniform Mechanical Code, State or Regional Codes)

Electrical codes: Optional Blower Assemblies have a flexible electrical cord that must be electrically grounded per local codes or per electrical codes:

In USA, NEC, ANSI/NFPA 70-1987
In Canada, CSA C22.1

WARNING: ELECTRICAL GROUNDING INSTRUCTIONS: THIS APPLIANCE IS EQUIPPED WITH A THREE-PRONG (GROUNDING) PLUG FOR YOUR PROTECTION AGAINST SHOCK HAZARD AND SHOULD BE PLUGGED DIRECTLY INTO A PROPERLY GROUNDED THREE-PRONG RECEPTACLE. DO NOT CUT OR REMOVE THE GROUNDING PRONG FROM THIS PLUG. DO NOT ROUTE POWER CORD UNDER OR IN FRONT OF APPLIANCE.

2. Local amendments?
3. Is a permit required - cost? (You may wish to contact your insurance company to ask if they require this)
4. Is outside combustion air required?
5. Rooms where the installation is not allowed?

SMOKE DETECTORS

Since there are always several potential sources of fire in any home, we recommend installing smoke detectors. If possible, install the smoke detector in a hallway adjacent to the room (to reduce the possibility of occasional false activation from the heat produced by the stove). If your local code requires a smoke detector be installed within the same room, you must follow the requirements of your local code. Check with your local building department for requirements in your area.

PLANNING YOUR INSTALLATION

FLOOR PROTECTION

This appliance requires non-combustible floor protector for ember protection. If the floor protection is to be stone, tile, brick, etc., it must be mortared or grouted to form a continuous non-combustible surface. If a chimney connector extends horizontally over the floor, protection must cover the floor under the connector and at least 2" (51 mm) to either side.

The floor protection must extend completely beneath the stove and to the front, sides, and rear as indicated:

USA REQUIREMENTS:

- 16" to the front of the fuel door glass
- 4½" beyond the sides of the pedestal base
- 0" to the back of the stove body

CANADA REQUIREMENTS:

- 18" (457 mm) to the front of the fuel door glass
- 8" (203 mm) beyond the sides of the pedestal base
- 8" (203 mm) to the back of the stove body

STANDARD PARALLEL HEARTH PAD SHOWN

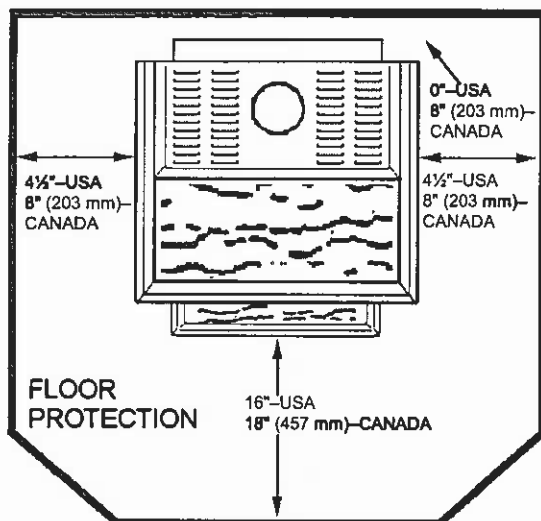

SELECTING A LOCATION

The design of your home and where you place your stove will determine its value as a source of heat. A wood stove depends primarily on air circulation (convection) to disperse its heat, and therefore, a central location is often best. There are other practical considerations, which must be considered before a final selection of locations is made.

- ◆ Existing Chimneys
- ◆ Wood Storage
- ◆ Aesthetic Considerations
- ◆ Roof Design (Rafter Locations & Roof Pitch)
- ◆ Room Traffic
- ◆ Proximity to Combustibles
- ◆ Electrical Wiring

The installation of this stove will require some research. Once your options are determined, consult with your local building department who will be able to give you the necessary installation requirements for your area (Is a building permit required, Rooms where installation may not be allowed, etc.).

WARNING: CHECK ALL LOCAL BUILDING AND SAFETY CODES BEFORE INSTALLATION. THE INSTALLATION INSTRUCTIONS AND APPROPRIATE CODE REQUIREMENTS MUST BE FOLLOWED EXACTLY AND WITHOUT COMPROMISE. ALTERATIONS TO THE STOVE ARE NOT ALLOWED. DO NOT CONNECT THE STOVE TO A CHIMNEY SYSTEM SERVING ANOTHER STOVE, APPLIANCE, OR ANY AIR DISTRIBUTION DUCT. FAILURE TO FOLLOW THESE INSTRUCTIONS WILL VOID THE MANUFACTURERS WARRANTY.

If you plan to vent your stove into an existing masonry chimney, have it inspected by a local fire marshal or qualified installer. Remember that a stove's performance is heavily influenced by the chimney and its location on the roof. An oversized flue may not provide effective draw, and a flue liner may be required (see *Draft Requirements* on page 10). Consult your dealer or qualified installer before final selection is made.

This stove requires pre-installation work to be completed before installation can take place. This will include the preparation of the floor and appropriate hearth pad for acceptance of outside air (if applicable), and for modification for flue and chimney.

PLANNING YOUR INSTALLATION

COMBUSTIBLE WALL CLEARANCE

WARNING: IT IS VERY IMPORTANT THAT YOU OBSERVE THE MINIMUM CLEARANCES.

There are listed clearances for your stove which were determined in a Laboratory test using various "classes" of stove pipe or chimney. Minimums are first established for the stove itself and increased based on how much heat is transferred by each class of pipe.

Note: Manufactured (mobile) home installations require the use of a Type L Vent Chimney connector only. Use of a single wall flue pipe connection is not permitted.

UNITED STATES REQUIREMENTS

Residential Reduced Clearance

Use listed double wall chimney connector or Type L vent pipe to the top of the stove. Clearances (Inches):

| | | |
|----------|--------|----------|
| A. 13.6" | C. 15" | E. 15" * |
| B. 25" | D. 6" | F. 5" * |

RESIDENTIAL STANDARD

Does not apply to manufactured (mobile) home installations. Using single wall connector pipe from the stove top up to the chimney support box. Clearances (inches):

| | | |
|----------|-----------|------------|
| A. 21.6" | C. 18" | E. 15" * |
| B. 25" | D. 13.75" | F. 7.75" * |

MANUFACTURED (MOBILE) HOME CLEARANCE

NOTE: Manufactured (Mobile) home installations require the use of a double wall chimney connector between the stove and the chimney as specified below. Use of a single wall flue pipe connection is not permitted. Chimney must be Simpson Dura-Vent Dura/Plus chimney with manufactured (mobile) home installation kit (Dura-Vent part number 6DP-MH). Chimney connector between stove and chimney must be Simpson Dura-Vent DVL close clearance connector pipe. Manufactured (Mobile) Home installations must use a rain cap with a spark arrester. Clearances (Inches):

| | | |
|----------|--------|----------|
| A. 13.6" | C. 15" | E. 15" * |
| B. 25" | D. 6" | F. 5" * |

PROTECTED WALL CLEARANCE

Some local codes will allow reduced clearances when the stove is installed adjacent to a protected wall system. The variance must be approved by your local building official. Normally, the protected wall system is defined as a non-combustible material with a minimum of 1" air space behind. Check your local building codes or with a qualified installer (Ref. NFPA 211).

CANADA REQUIREMENTS

This appliance is not approved for installation into a manufactured (mobile) home in Canada.

Residential Reduced Clearance

Use listed double wall chimney connector or Type L vent pipe to the top of the stove. Clearances (Centimeters):

| | | |
|------------|------------|--------------|
| A. 44.5 cm | C. 40.5 cm | E. 51.0 cm * |
| B. 76.0 cm | D. 25.5 cm | F. 15.0 cm * |

Residential Standard

Using single wall connector pipe from the stove top up to the chimney support box. Clearances (Centimeters):

| | | |
|------------|------------|--------------|
| A. 62.5 cm | C. 53.5 cm | E. 51.0 cm * |
| B. 76 cm | D. 42.5 cm | F. 27.5 cm * |

Corner Installation

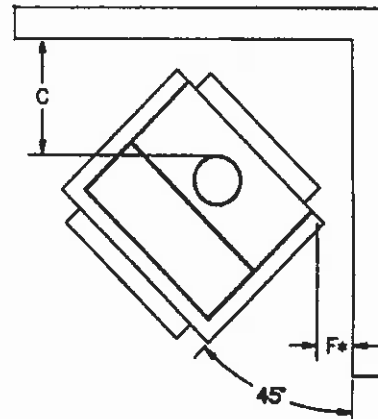

Parallel Installation

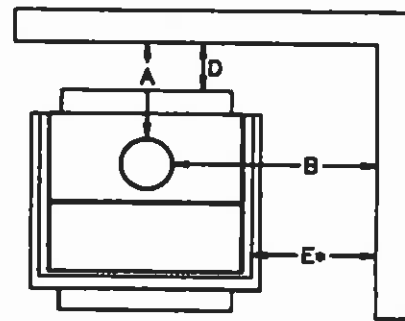

* Note: E and F dimensions are measured to side of stove below the projection of outer top.

INSTALLATION

MANUFACTURED (MOBILE) HOME REQUIREMENTS

Approved for USA only. This appliance is not approved for installation into a manufactured home in Canada.

This stove is certified as a Room Heater, Solid Fuel Type and may be used in Manufactured Housing providing the following requirements are followed:

- **WARNING: DO NOT INSTALL IN SLEEPING ROOM.**
- An outside air inlet must be provided for combustion and be unrestricted while unit is in use.
- Regulations require that the appliance must be secured to the floor and grounded to the chassis. See *Securing the Stove to the Floor (and) Grounding Stove*, following.
- **CAUTION: THE STRUCTURAL INTEGRITY OF THE MOBILE HOME FLOOR, WALL, AND CEILING/ROOF MUST BE MAINTAINED.**

VENTILATION REQUIREMENTS

THE FRESH AIR REQUIREMENTS OF THIS APPLIANCE MUST BE MET WITHIN THE SPACE WHERE IT WILL BE INSTALLED.

Ventilation is essential when using a solid fuel burning heater. The combustion process of this heater uses oxygen from inside the dwelling and it may be necessary to open a window or to duct outside combustion air directly to the appliance (as outlined in this manual). Modern construction standards have resulted in homes that are highly energy-efficient and that allow little heat loss and air transfer. Other appliances in the dwelling also contribute to removing air from the dwelling (i.e. clothes dryers, exhaust fans, fireplaces, and other fuel burning appliances). If the available fresh air delivery in the dwelling is insufficient to support the demands of these appliances, problems can result (i.e. excessive negative pressure can develop in the dwelling which will affect the rate at which this appliance can draft [See *Draft Requirements*, page 10], icing can develop in some environments, etc.).

OUTSIDE COMBUSTION AIR

The following 2 optional kits are required to deliver outside air to this appliance. Contact your dealer to order.

Catalog # 14M67 Outside Air Floor Duct

Catalog # 14M68 Back Cover Plate

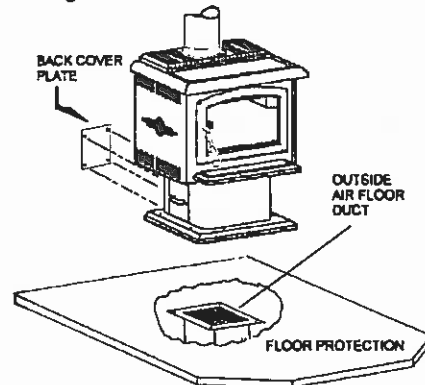

In all manufactured (mobile) homes and in many site built residences (subject to local code), a stove may be required to use outside air for combustion. A 5 1/4" square" outside air floor duct Back Cover Plate is available through your dealer.

This stove can take in outside air directly through the base. This type installation requires a hole through the floor protector and the use of outside air floor duct to penetrate into the air space below the home.

NOTES: The floor air duct can be positioned anywhere 2" in from either side under the pedestal. The floor air duct opening must be protected from any possible obstruction including loose floor insulation. This part can be purchased from your local dealer.

SECURING THE STOVE TO FLOOR

Manufactured (Mobile) Homes Only

Once the floor air duct and hearth pad are in position confirm that the hole of the hearth pad is aligned with the outside air opening. Next position and align the stove on the hearth pad. Manufactured Home installations require that the stove be secured to the floor. This ensures that the stove will not shift if the Manufactured Home is ever moved. To do this, drill two holes (use a marking instrument long enough and small enough to fit through the (4) four holes in the pedestal base and mark the hearth pad. Then remove the stove. Drill the (4) four holes, (2) two on each side of the pedestal base) with a 1/4" drill bit. Drill down through the hearth pad and the Manufactured Home floor. Use 1/4" lag bolts and secure to the Manufactured Home floor.

NOTE: If the composition of the manufactured home floor is of light particleboard construction, you will be required to secure the stove with regular hex head bolts and nuts. This will ensure that the bolts will not rip out of the floor when the manufactured home is being moved.

INSTALLATION

GROUNDING STOVE

Manufactured (Mobile) Homes Only

Regulations require that all stoves installed in Manufactured Homes must be grounded. To do this simply attach a piece of No. 8 copper wire, at least 18" in length from the stove to the chassis of the Manufactured Home.

INSTALLING MARBLE ACCENTS

Marble is a natural product and therefore each piece will have its own unique character. Marble can be scratched so care should be taken to avoid putting heavy or rough objects (trivet/steamers) on the surface. If the marble should become scratched, the scratch may be removed or diminished by polishing it with jewelers rouge (which can be purchased at many hardware stores). Do not install the marble before curing the paint.

The marble set consists of 2 pieces. A large piece which fits onto the stove top and a smaller piece which fits onto the ashlip (located below the fuel door).

Installation Steps:

Install the cerawool blanket, gasket strips and marble set as follows:

1. Place the cerawool blanket and gasket strips onto the stove top as shown in the following illustration.

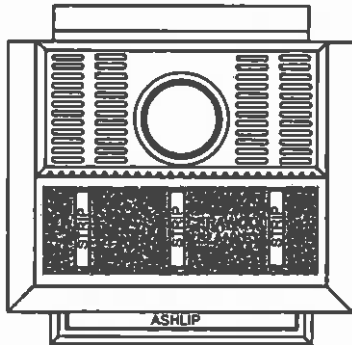

PLACE CERAWOOL BLANKET ON STOVE TOP. PLACE STRIPS ON TOP OF BLANKET AS SHOWN.

2. Place the larger marble piece on top of the cerawool blanket and strips.
3. Place the smaller marble piece into recessed area on the stove ashlip (located below the fuel door). The ashlip marble requires no insulation.

REMOVE ASH DRAWER CLIP

The ash drawer is secured for shipping with a small retaining screw at the top of drawer. Remove and discard this screw.

BAFFLE PLATES

This appliance has two heavy steel baffle plates that are installed in the upper firebox (over the steel secondary air supply tubes). During shipment and installation, the baffle plates might slide around, and may need to be repositioned (lined up to each other) and pushed to the back wall in order for the stove to operate properly. When in the proper position, the rear edges of the baffle plates should be flush to the back wall of the firebox. See *Removing Baffle Plates for Cleaning* on page 17 for additional information on installing baffle plates.

TYPES OF CHIMNEYS

The chimney is a vital part of your stove installation. A properly built masonry chimney or a properly installed factory built chimney will assure a consistent draft under a variety of weather conditions (a smoking stove is usually caused by a chimney problem). The stove flue size is 6 inches diameter, which is approximately 28 square inches minimum. The maximum flue size should be no more than (3)-three times the cross sectional area of the size of the stove flue collar. In this case, that would be no larger than a 10-inch diameter stack, or approximately 85 square inches maximum.

All chimneys must be installed as specified by local building codes and according to the chimney manufacturer instructions (in the case of a factory built chimney). See the chimney manufacturer instructions for exact specifications. Factory built chimneys must comply with UL 103HT or ULC S629.



Tile-lined masonry chimney



Factory built chimney

INSTALLATION

ACCEPTABLE CONNECTOR PIPE FOR INSTALLATIONS

For Standard Residential Clearances: Six (6) inch minimum, single wall, minimum MSG black or 25 MSG blued steel connector pipe with listed factory-built chimney suitable for use with solid fuels or masonry. Three (3) pre-drilled holes are provided in the flue collar for fastening the pipe securely to the stove. Use sheet metal screws to do this. Additional sections of single wall pipe should be fastened together with at least three (3) sheet metal screws each section. When connecting to the factory built ceiling support package, use the manufacturer's transition piece, usually called a dripless connector, to join single wall pipe to their factory built chimney section.

Minimum Flue Size - The required minimum diameter and area required for the flue size is (respectively) 6 inches / 152 mm diameter, which is approximately 28 square inches / 711 square mm. The maximum flue size should be no more than (3) three times the cross sectional area of the size of the 6 inches / 152 mm diameter flue collar. In this case, that would be no larger than a 10 inch (254 mm) diameter (area = approx. 85 sq. inches [216 sq. cm]).

Connection To A Factory Built Chimney - This space heater is to be connected to a factory-built chimney conforming to CAN / ULC – S629, Standard for 650°C Factory-Built Chimneys.

For Reduced Residential Clearances: Type L and listed double wall connector pipe is acceptable. Install any factory built brand of pipe according to the manufacturer's instructions.

Vapor Barrier at Chimney Penetration

Install all venting components per the Vent Manufacturers installation instructions. Ensure that there is an effective vapor barrier at the location where the chimney penetrates to the exterior of the structure. This can be accomplished by applying a non-hardening waterproof sealant to the following components:

- Around the chimney at the point where the storm collar will meet the chimney just above the Flashing.
- Along the vertical seam of the chimney pipe, where it is exposed to the weather.
- On each nail head on the flashing.
- Around the chimney at the point where the storm collar will meet the chimney just above the flashing.

Notes:

- On a flat or tarred and graveled roofs, nail and seal the flat roof flashing to the roof on all sides with roofing compound.
- Do not put screws through the flashing into the chimney pipe.

CHIMNEY INSPECTION

Existing chimneys must be inspected before installing your stove. Consult your local building department for chimney code requirements. A masonry chimney must have a code approved liner. This liner must not have broken or missing pieces. Some non-code masonry chimneys may be brought up to code by being relined. (Consult your dealer or qualified chimney sweep). Factory built chimneys should also be inspected, first for creosote deposits (which should be removed), and then for integrity of the stainless steel liner.

Look for obvious bulges in the lining which may indicate the need to replace that section (use a bright flashlight). Also, inspect the attic to see that the chimney has proper clearance to combustible framing members. For interior masonry chimneys and most factory built chimneys, this must be a (2) two inch air space clearance, which must not be filled with insulation or any other material. An exterior masonry chimney must have a (1) one-inch air space clearance.

INSTALLATION

CHIMNEY HEIGHT REQUIREMENTS

The chimney must extend 3 feet above the level of roof penetration and a minimum of 2 feet higher than any roof surface within 10 feet (see below). Check with your local building officials for any additional requirements for your area.

Due to prevailing winds, local terrain, adjacent tall trees, a hill, or ravine near the home, or adjacent structures, additional chimney height or a special chimney cap may be required to ensure optimum performance.

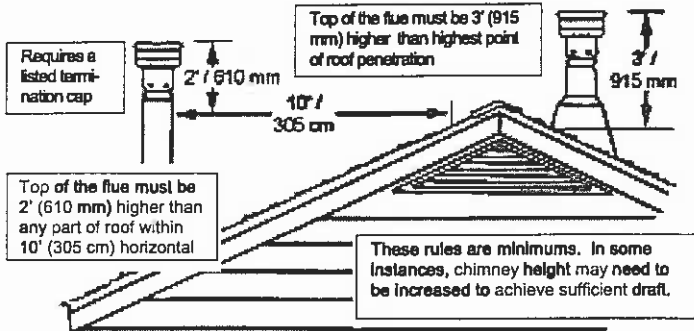

To achieve a stable draft, the total flue height required (from the appliance to termination) is 12 to 15 feet minimum.

For Manufactured (Mobile) Homes Only: Portions of the chimney and termination that exceed an elevation of 13½ feet above ground level may be designed to be removed for transporting the manufactured home.

DRAFT REQUIREMENTS

The appliance is merely one component of a larger system. The other equally important component is the venting system. This is necessary for achieving the required flow of combustion air to the fire chamber and for safely removing unwanted combustion byproducts from the appliance. If the venting system's design does not promote these ends, the system may not function properly. Poorly functioning venting systems may create performance problems as well as be a safety hazard (i.e. an oversized chimney may result in less than optimum performance. Installations into a large, masonry chimney may require a liner to improve performance). A draft test should read greater than .04' W.C. (inches water column) and less than .08" W.C.

American National Standards Institute ANSI/NFPA 211-92, draft 1-7: A chimney or vent shall be so designed and constructed to develop a flow sufficient to completely remove all flue and vent gases to the outside atmosphere. The venting system shall satisfy the draft requirements of the connected appliance in accordance with the manufacturer's instructions.

INSTALLATION

RESIDENTIAL STANDARD

Using 6" Diameter Single Wall Connector Pipe
Not Approved For Manufactured (Mobile) Homes

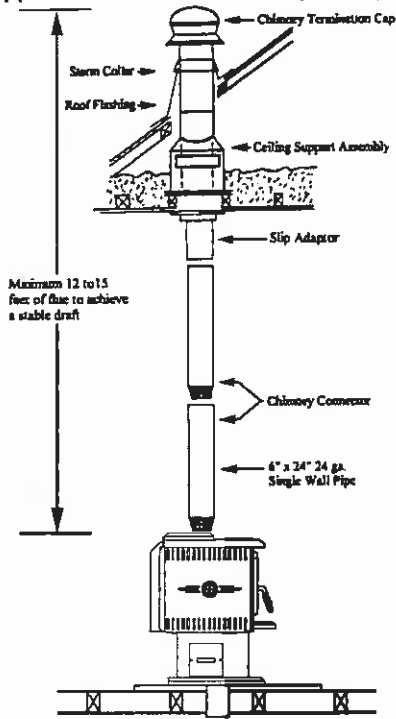

MANUFACTURED (MOBILE) HOME STANDARD - Using 6" Diameter Type L-Vent Connector Pipe

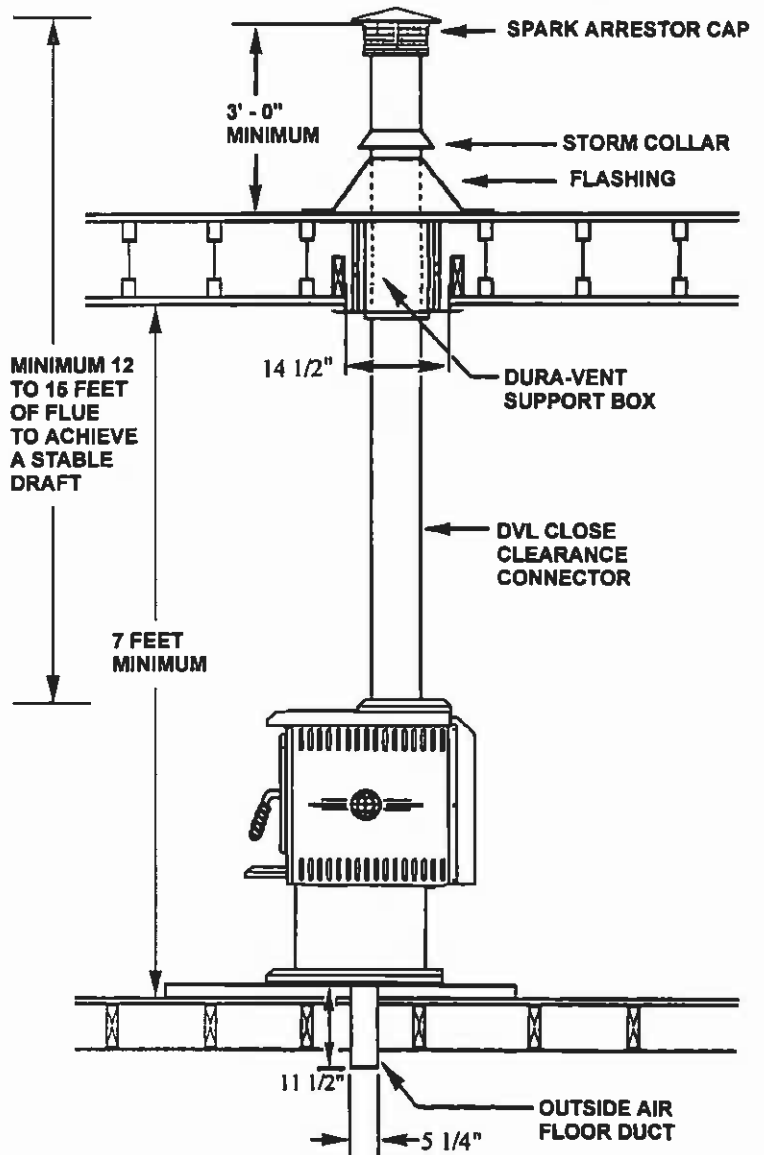

MANUFACTURED (MOBILE) HOME STANDARD - Using 6" Diameter Type L-Vent Connector Pipe

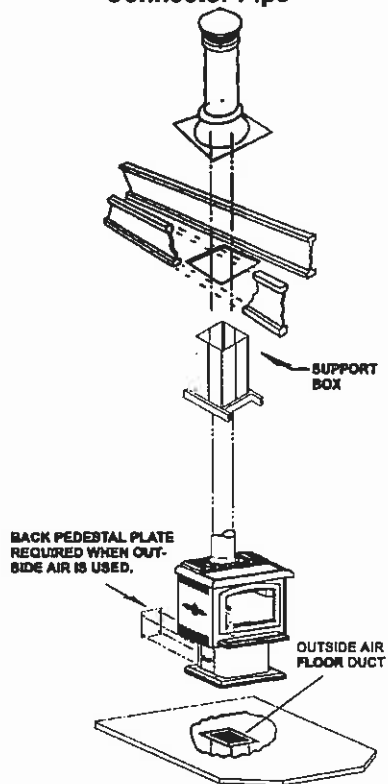

INSTALLATION Combustible Wall Chimney Connector Pass-Throughs

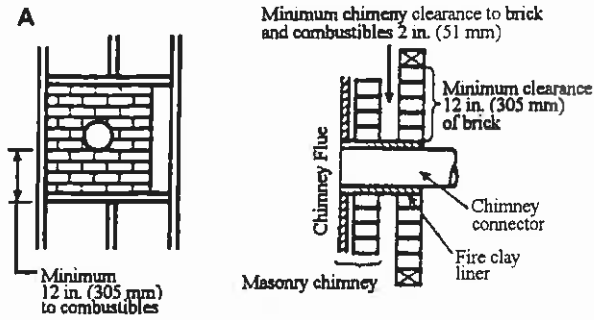

Method A. 12 inch (305mm) Clearance to Combustible Wall Member: Using a minimum thickness 3.5 inch (90 mm) brick and a 5/8 inch (16 mm) minimum wall thickness clay liner, construct a wall pass-through. The clay liner must conform to ASTM C315 (Standard Specification for Clay Fire Linings) or its equivalent. Keep a minimum of 12 inches of brick masonry between the clay liner and wall combustibles. The clay liner shall run from the brick masonry outer surface to the inner surface of the chimney flue liner but not past the inner surface. Firmly grout or cement the clay liner in place to the chimney flue liner.

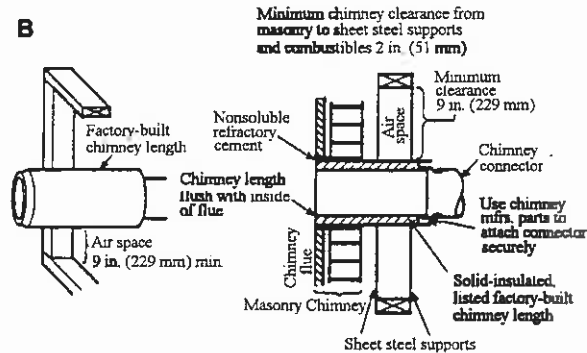

Method B. 9 inch (229mm) Clearance to Combustible Wall Member: Using a 6 inch inside diameter, listed, factory-built Solid-Pak chimney section with insulation of 1 inch (25.4 mm) or more, build a wall pass-through with a minimum 9 inch air space between the outer wall of the chimney length and wall combustibles. Use sheet metal supports fastened securely to wall surfaces on all sides, to maintain the 9-inch air space. When fastening supports to chimney length, do not penetrate the chimney liner (the inside wall of the Solid-Pak chimney). The inner end of the Solid-Pak chimney section shall be flush with the inside of the masonry chimney flue, and sealed with a non-water soluble refractory cement. Use this cement to also seal to the brick masonry penetration.

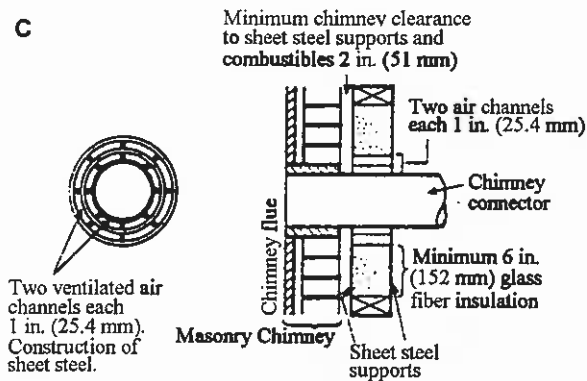

Method C. 6 inch (152mm) Clearance to Combustible Wall Member: Starting with a minimum 24 gage (.024 inch [.61 mm]) 6-inch metal chimney connector, and a minimum 24 gage ventilated wall thimble which has two air channels of 1 inch each, construct a wall pass-through. There shall be a minimum 6 inch separation area containing fiber glass insulation, from the outer surface of the wall thimble to wall combustibles. Support the wall thimble, and cover its opening with a 24-gage minimum sheet metal support. Maintain the 6-inch space. There should also be a support sized to fit and hold the metal chimney connector. See that the supports are fastened securely to wall surfaces on all sides. Make sure fasteners used to secure the metal chimney connector do not penetrate chimney flue liner.

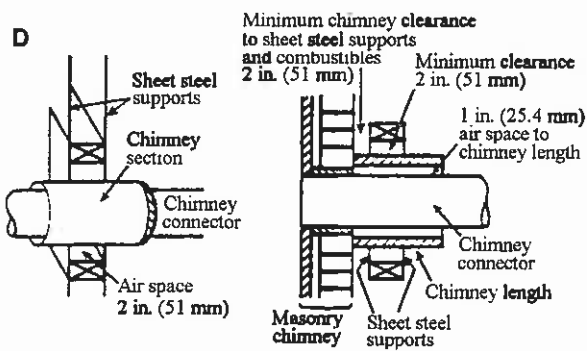

Method D. 2 inch (51mm) Clearance to Combustible Wall Member: Start with a solid-pak listed factory built chimney section at least 12 inches (305mm) long, with insulation of 1 inch (25.4mm) or more, and an inside diameter of 8 inches (2 inches [51 mm] larger than the 6 inch chimney connector). Use this as a pass-through for a minimum 24-gage single wall steel chimney connector. Keep solid-pak section concentric with and spaced 1 inch off the chimney connector by way of sheet metal support plates at both ends of chimney section. Cover opening with and support chimney section on both sides with 24 gage minimum sheet metal supports. See that the supports are fastened securely to wall surfaces on all sides. Make sure fasteners used to secure chimney section do not penetrate chimney flue liner.

Notes:

1. Connectors to a masonry chimney, excepting method B, shall extend in one continuous section through the wall pass-through system and the chimney wall, to but not past the inner flue liner face.
2. A chimney connector shall not pass through an attic or roof space, closet or similar concealed space, or a floor, or ceiling.
3. Where passage through a wall, or partition of combustible construction is desired, the installation shall conform to CAN/CSA-B365.

PRODUCT FEATURES AND CONTROLS

ASH DRAWER

The large ash drawer located on the left side of the pedestal is designed to make cleaning easier by containing the ashes in a removable drawer.

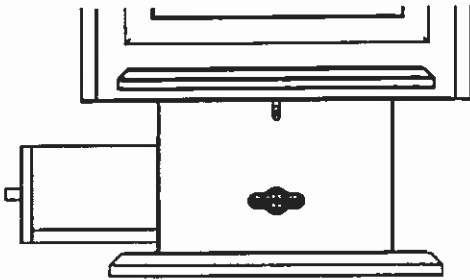

CAUTION: DO NOT OPERATE THE STOVE WITH THE ASH DRAWER OPEN OR AJAR, AS THIS WILL PRODUCE EXTREME TEMPERATURES WITHIN THE STOVE (OVERFIRING) AND COULD CAUSE DAMAGE (SUCH DAMAGE IS NOT COVERED BY THE MANUFACTURERS WARRANTY). REPLACE THE ASH DRAWER GASKET IF IT BECOMES FRAYED OR DAMAGED.

PRIMARY AIR CONTROL

The primary combustion air delivery is controlled by the Primary Air Control Assembly (the control handle is located below the fuel door). The heat output can be controlled by pushing the control handle in, then incrementally pulling out to the desired heat output setting (See Care and Operation Section – *Primary Air Control*, page 14). The fuel, the amount of heat and burn times desired, the type of installation are all variables that will affect the control setting. The same control settings in a variety of installations will produce different results. You will need to try different settings so you can learn how much heat to expect and how long the fire will burn.

Primary Air Control Handle

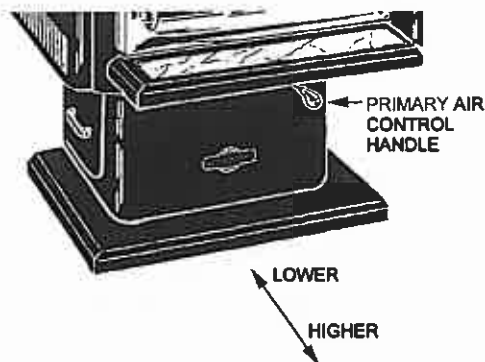

PUSH IN ALL THE WAY (TO RESET CONTROL PLATES), THEN PULL OUT IN INCREMENTS TO DESIRED HEAT OUTPUT SETTING.

CARE AND OPERATION

GOLD DOOR

The doorframe is plated with 24-karat industrial grade gold and requires curing to harden the gold. Once it is cured it will never tarnish. Prior to burning this appliance the doorframe should be cleaned thoroughly with a good window cleaning solution and a soft cloth. Do not use any metal polishes or abrasives to clean the gold surface. Any oils or fingerprints left on the gold could become permanent blemishes if the stove is burned prior to their removal. After the first few fires, the gold will cure. The $\frac{3}{4}$ " diameter door rope gasket is made of highly durable high temperature resistant material. It must be kept in good condition. Do not leave the stove burning with the door ajar or open. Leaving the door ajar or open while the stove is burning will cause excessive heat build up in the stove (overfiring) and could ignite surrounding combustibles as well as damage the stove (such damage is not covered by the manufacturer's warranty).

CAUTION: WHEN OPENING THE DOOR, DO NOT EXTEND IT BEYOND ITS NORMAL TRAVEL. OVEREXTENDING THE DOOR TO A FURTHER OPEN POSITION CAN PUT EXCESSIVE STRESS ON HINGE AREA OF DOOR AND HINGE PINS AND MAY RESULT IN BREAKAGE.

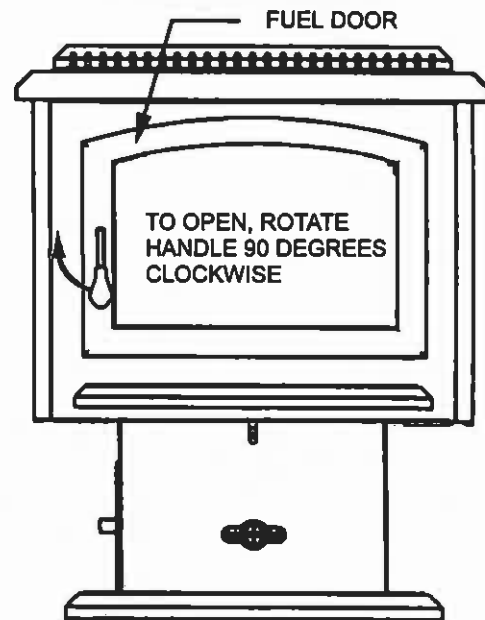

DOOR OPERATION

The door handle assembly opens and securely latches the fuel door closed. To open the door, rotate the coil handle to the 9:00 position until door releases. To close and latch, hold the coil handle in the 9:00 position, close the door, then rotate the handle to the 6:00 position. See illustration above.

CARE AND OPERATION

GLASS

The Glass is a super heat resistant ceramic that withstands continuous temperatures up to 1390° F. This temperature is well beyond the temperatures in which you operate your stove.

This unit is designed to provide a flow of air over the inside of the glass, where along with high heat helps keep it clean. When operating the stove on low for extended periods of time, the glass may get dirty. A short, hot fire (15 - 20 minutes) will help clean off much of the normal buildup (see *Troubleshooting*, page 19). A commercial glass cleaner designed for stoves is recommended for cleaning.

The glass should be cleaned thoroughly with glass cleaner and a soft cloth BEFORE the stove is burned.

PRIMARY AIR CONTROL

The Model 1900HT-M has one combustion air control located under the ash lip.

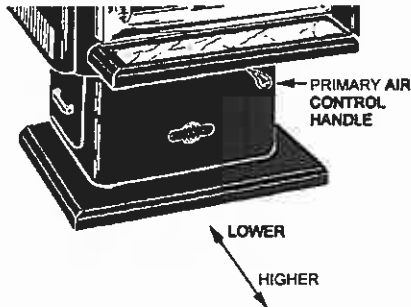

PUSH IN ALL THE WAY (TO RESET CONTROL PLATES). THEN PULL OUT IN INCREMENTS TO DESIRED HEAT OUTPUT SETTING.

Start-up: To provide sufficient combustion air to achieve a clean burn as quickly as possible, the 1900HT-M has the ability to supplement its primary air with extra "Start-Up" air. This is achieved by pulling the air control all the way out, and should only be adjusted to this setting when starting a fire, when refueling or otherwise for short duration's only.

CAUTION: OPERATION WITH PRIMARY AIR CONTROL IN "START-UP" POSITION (PULLED ALL THE WAY OUT) FOR EXTENDED PERIODS, WASTES FUEL AND CAN CAUSE DANGEROUS OVERFIRING CONDITIONS. NEVER LEAVE STOVE UNATTENDED ON HIGH SETTINGS.

Start-up Control Plate Positions



Adjusting Burn Rate: The primary air control handle can be pulled out to the open position for higher temperatures and moved in to a more closed position for lower temperatures.

IMPORTANT: Push air control all the way in (closed) before pulling rod out to set desired burn rate. This clears the high burn control plate so it is not left open.

Generally, you will want to set the air control somewhere in the low or medium range.

Low Burn - (approx. 9,000-13,000 Btu/hr.). Pull control handle out approx. 3/4".

Low Burn Control Plate Positions

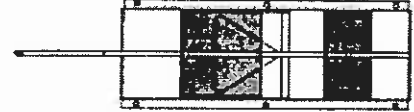

Medium - Burn (approx. 13,000-16,000 Btu/hr.). Pull control handle out approx. 1 1/2".

Medium-Low Burn - Control Plate Positions

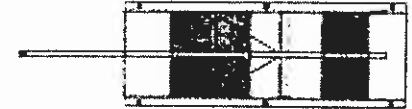

Medium-High Burn (approx. 16,000-25,000 Btu/hr.). Pull control handle out approx. 2 1/2", until small click is felt.

Medium High Burn - Control Plate Posi- tions



High Burn (Maximum - approx. 44,000 Btu/hr.) Pull control handle out to its full extended position.

WARNING: OPERATING STOVE ON HIGH FOR EXTENDED PERIODS WASTES FUEL, AND WILL CAUSE A WHITE BUILD-UP (HAZE) ON GLASS AND CAN CAUSE DANGEROUS OVERFIRING CONDITIONS. NEVER LEAVE STOVE UNATTENDED ON HIGH.

High Burn - Control Plate Positions

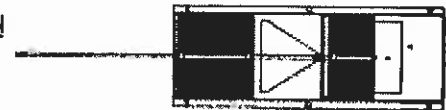

PROVIDE ADEQUATE AIR FOR COMBUSTION

In well insulated and weather tight homes, it may be difficult to establish a good draft up your chimney. The poor draft is caused by a shortage of air in the house. To provide the needed air, crack a window on the windward side of the house.

In some cases, you may want to duct air directly from the outside to your firebox (See *Outside Combustion Air*, page 7), or to a nearby floor or wall vent.

USE CONTROL SETTINGS THAT WORK FOR YOU

The fuel, the amount of heat you want, the type of installation you have and how long you wish the fire to burn are all variables that will affect the control setting. The same control settings in a variety of installations will produce different results.

Familiarize yourself with your stove by trying different settings so you can learn how much heat to expect and how long the fire will burn. It may take a week or two to learn but your patience will be rewarded by the warmth and pleasant satisfaction that only a wood fire can provide.

CARE AND OPERATION

BREAK-IN PERIOD

Your stove finish is a high temperature paint that requires time and temperature to completely cure. We recommend that you ventilate the house during the initial burns. The paint emits non-toxic odors during this process.

KEEP YOUR HOUSE WELL VENTILATED DURING THE CURING PROCESS TO PREVENT ACTIVATION OF YOUR HOME SMOKE DETECTOR.

The paint manufacturer recommends three burn cycles to cure the paint. The first two burns should be low heat, approximately 250°F., for 20 minutes each, using paper and light kindling.

After each 20-minute burn, allow the appliance to cool completely. The third burn should be at least medium high or about 450°F. for 45 - 60 minutes. The paint will become soft and emit non-toxic haze during these burns. Keep the area well ventilated.

As the paint cures it will become slightly lighter in color. Eventually the entire surface will become an even color. Once the paint has been softened and cooled two or three times, it will harden. Do not turn on a blower during the curing process. Do not place anything on the stove surface until the paint is completely cured. Do not attempt to repaint the stove until the paint is completely cured. If the surface later becomes stained or marred, it may be lightly sanded and touched up with spray paint from the same paint (See *Small Area Paint Touch-up*, page 17). Paint is available at your local authorized Lennox Hearth Products dealer. Never attempt to paint a hot stove.

FIRST FIRE

When your installation has been completed and inspected you are ready to build your first fire.

1. Pull the primary air control to the full open position (located below the ash lip).
2. Open door and build a small fire in the stove using paper and dry kindling. Wait a few minutes for a good updraft to establish the fire.
3. Now place two or three thoroughly dried logs on the burning kindling and secure door.
4. After about 25-30 minutes of burning (when fire is well established), push in the primary air draft control (this will reset control plates), then pull out to a medium setting. This will keep the fire burning at a moderate level so heat is transferred through the stove rather than up the chimney.
5. Once a bed of coals has been established, adjust the air-intake draft control to a low by pushing the air control rod all the way in (closed) and then pulling the rod out incrementally to a low or medium-low setting. This action clears the high burn control plate so it is not left open.
6. During the first few fires, keep the combustion rate at a low to moderate level. Avoid burning fires with the draft control wide open for long periods of time. This results in an updraft fire with most of the heat escaping up the chimney.

WARNING! READ AND USE THE INFORMATION PROVIDED IN THIS SECTION. TO DISREGARD THIS MAY CAUSE SERIOUS PERMANENT DAMAGE TO THE STOVE AND VOID YOUR WARRANTY. IT IS BEST TO WARM YOUR STOVE UP SLOWLY AND KEEP IT AT A MODERATE LEVEL.

CARE AND OPERATION

HOW TO START AND MAINTAIN A FIRE

1. Open the primary air control by pulling the handle outward to the full open position. This allows the firebox and fresh fuel to quickly come up to ideal operating temperature.
2. Build your fire directly on the firebrick covering the bottom of the stove.
 - a. Place five or six loosely crumpled sheets of newspaper in the stove.
 - b. Add a small amount of dry kindling randomly on the top of the newspaper.
 - c. Place a few more loosely crumpled newspapers on top of the kindling and light the bottom paper first, then light the top paper. Once the fire is well underway, close the fuel door. The upper fire should preheat the chimney and create an effective draft while the lower fire ignites the kindling.
3. After the kindling is burning well, add increasingly larger pieces of wood until the fire is actively burning.
4. Once a bed of coals has been established, adjust the primary air control to a lower setting by pushing the air control rod all the way in (closed) and then pulling the rod out incrementally to the desired setting. Tips - Adjust the primary air control to a medium to low setting for a slow and more efficient burn. On higher settings, it is more efficient to burn with a bright but not roaring fire.

REFUELING

To refuel the stove, first move the primary air control to high (pulled out). Let the fire "liven up" for about one minute. Open the fuel door about 1/2" and hold in this position about 30 seconds or until stove is drafting well. Open the door and add wood. If the fire or coal bed is almost depleted and a full load of cord wood is added, it may be necessary to adjust the primary air control wide open to re-establish a lively fire. The use of start-up air should only be used for a short period of time.

NOTE: After refueling and the wood is burning at a brisk rate, reset the primary air control to the desired position by pushing the primary air control rod all the way in and then pull it back out to the desired setting.

FUEL

BURN RECOMMENDED FUEL

This appliance is approved for use with untreated natural dry wood only (see *Important Warnings*, page 2, No. 8). Do not burn particleboard scraps or pressed logs using bonding agents because they can produce conditions which will deteriorate metal. Green or uncured wood does not work well as fuel, and can cause increased creosote buildups. The value of green wood as a source of heat is limited. Do not overload or use kindling wood or mill ends as primary fuel as this may cause overfiring. Overfiring is a condition where excessive temperatures are reached, beyond the design capabilities of the stove. The damage that occurs from overfiring is not covered under the stove warranty.

WHY SEASONED WOOD?

The key to the success of a good fire that produces heat from a woodstove is the wood. It needs to be well-seasoned natural wood.

What does "Well-Seasoned" mean?

When a tree is cut down, the wood is green, full of sap and moisture. This moisture content can exceed 80%, which must be reduced to less than 20%. Wood properly seasoned is then capable of generating the heat the stove was designed to provide.

Green wood does not burn easily. Attempting to burn green wood often results in a lot of smoke and very little fire. Time is the most important factor in seasoning wood. Ideally the moisture content should be reduced to 11-20%, although very few of us will be able to check that figure. There are several steps that should be taken to ensure that that you come close to these figures.

SEASONING GUIDE

Softwoods – 6 months to 18 months
Hardwoods – 12 months to 24 months

Logs that are 5" diameter across or larger should be split in half, three pieces if over 8 inches, and four pieces when over a foot across. If the tree fell 2 to 4 years ago, it still needs to be cut, split, and seasoned for 6 to 24 months depending on the wood.

WOOD STORAGE

Wood to be seasoned should be stacked in an area open enough to ensure good air circulation on both sides – leaving adequate space between woodpiles to walk comfortable. Do not stack wood against a wall or building. It helps to elevate the woodpiles off the ground (two 2 x 4's running lengthwise beneath the woodpile works well). This allows air to flow under the bottom logs.

Wood that is kept outdoors, either covered with a tarp, or not covered at all, will not burn well until it has been in an enclosed space for one to two months.

MAINTENANCE

SMALL AREA PAINT TOUCH-UP

The stove body is painted with a quality high-temperature stove paint. Use only model TSPK-B Stove Paint, Catalog # 70K99. Do not touch-up your stove with any other paint.

Using one small piece of 320 grit sand paper and lightly sand the blemish so that the edges are "feathered" or smooth to the touch between the painted and bare surfaces. Do not let the sand paper gum up with paint, as this will cause scratches on the metal surface. If there are any scratches, use 600 grit sandpaper instead. Mask off surfaces you do not want painted. Paint lightly over the bare surface first as this will act as an undercoat. Then paint over a larger area in smooth even strokes to blend.

See **Break-In Period** on page 15 for information on curing the paint.

FIREBRICK

The firebrick should be inspected periodically and replaced if damaged (crumbling or excessively cracked).

ASH REMOVAL AND DISPOSAL

CAUTION: MAKE SURE THAT THE FIRE IS OUT AND THE STOVE IS COLD BEFORE REMOVING ASHES! NEVER BURN YOUR STOVE WITH THE ASH DRAWER OPEN OR UNSECURED!

Ashes can hold live embers for several days, and must be disposed of with care.

Scrape ashes from the firebox through the grate into the ash drawer. After emptying, clean and replace the ash drawer and tighten the securing knobs.

NEVER place ashes in a cardboard box or any other combustible receptacle.

Proper Disposal of Ashes:

Ashes should be placed in a metal container with a tight fitting lid. The closed container of ashes should be placed on a noncombustible floor or on the ground, well away from all combustible materials, pending final disposal. If the ashes are disposed of by burial in soil or other wise locally dispersed, they should be retained in the closed container until all cinders have thoroughly cooled.

Note: The removable ash drawer holds approximately two gallons of ashes.

DOOR, GLASS AND ASH DRAWER GASKETS

A 3/4" spun fiberglass rope gasket provides the seal around the fuel door and a 1/8" x 1" flat woven gasket glass provides the seal around the glass. And a 1/4" spun fiberglass gasket provides a seal around the ash drawer. Should these gaskets become frayed or damaged they should be replaced with the same size and type as the original gasket. Contact your dealer for ordering. Use high temperature silicone sealer as an adhesive for the door gasket. The glass gasket and ash drawer gaskets have a self-adhesive backing (see *Replacement Parts*, pages 20-21).

WARNING: THE GASKETS MUST BE KEPT IN GOOD CONDITION. DO NOT LEAVE THE STOVE BURNING WITH THE DOOR OR ASH DRAWER OPEN OR AJAR. THIS WILL CAUSE EXCESSIVE HEAT BUILD UP IN THE UNIT AND COULD IGNITE SURROUNDING COMBUSTIBLES AS WELL AS DAMAGE THE STOVE BY OVERFIRING IT. OVERFIRING IS A CONDITION WHERE EXCESSIVE TEMPERATURES ARE REACHED, BEYOND THE DESIGN CAPABILITIES OF THE STOVE (SUCH DAMAGE IS NOT COVERED BY THE MANUFACTURERS WARRANTY).

SERVICING GLASS

CAUTION: BE CAREFUL NOT TO ABUSE DOOR ASSEMBLY BY STRIKING OR SLAMMING IT. IF THE DOOR ASSEMBLY OR GLASS IS BROKEN OR DAMAGED, THEY MUST BE REPLACED BEFORE HEATER CAN BE SAFELY OPERATED. USE ONLY COMPONENTS PROVIDED BY THE MANUFACTURER AS REPLACEMENT PARTS.

Cleaning Glass: Ensure stove is cold prior to cleaning glass. A commercial glass cleaner designed for stoves is recommended. Do not use abrasive cleaners.

Replacing Glass:

1. Remove door from stove by lifting door up and off hinge pins: Place the door on a flat protected (towel) clean flat surface with the inside of the door facing up. Remove the glass clips (by removing screws holding clips), then carefully remove broken glass one piece at a time (protective gloves are recommended).
2. Clean the area where the glass with gasket will be installed.
3. Install new glass with gasket (use only factory 5-mm glass with glass channel gasket. Do not substitute). Carefully reinstall glass clips. Be very careful not to overtighten screws.
4. Reinstall door.

MAINTENANCE

CREOSOTE FORMATION AND NEED FOR REMOVAL

What is Creosote - When wood is burned slowly, it produces tar and other organic vapors, which combine with expelled moisture to form creosote. The creosote vapors condense in the relatively cool chimney flue of a slow-burning fire. As a result, creosote residue accumulates on the flue lining. When ignited this creosote makes an extremely hot fire. Also, creosote deposits tend to form in long runs of venting where gases become too cool prior to exhausting. Note: Single wall pipe cools rapidly, therefore installations using this type of flue are more susceptible to creosote deposits.

To inhibit the build up of creosote, adjust the primary air control to a medium-high or high setting for a 10-minute period each day. Do not attempt to burn out heavy creosote accumulations in this manner. This must be removed from the chimney by scraping or brushing to reduce the risk of a chimney fire.

Burn Approved Fuel Only - This stove is approved for burning dry seasoned natural wood only. Using green or inadequately seasoned wood may increase creosote buildup.

Inspection Frequency - The chimney connector and chimney should be inspected at least twice monthly during the heating season to determine if a creosote buildup has occurred. If creosote has accumulated it should be removed to reduce the risk of a chimney fire.

Cleaning - Remove the baffle plates in the firebox prior to having your chimney cleaned (should be done by a qualified chimney sweep). See following – *Removing Baffle Plates for Cleaning*).

Removing Baffle Plates for Cleaning

Note: The smoke baffle in the upper firebox area consists of two heavy gage steel plates. One of these plates has a welded strap to overlap the seam, which runs front to back between the two. Before removing the baffle plates from the firebox, wearing a pair of leather or work gloves is recommended.

1. To remove the baffle, reach inside the firebox and slide one plate over the other.
2. Next move the metal plates, stacked one on top of the other, sideways toward the center of the stove.
3. Then move the two baffle plate toward the front of the stove to clear the ledge they rest on at the rear. Be mindful these metal plates are quite heavy, so use care in lowering them out of the way.
4. Once the baffle plates are out of the firebox, the flue can be cleaned. The accumulated soot that is removed by brushing will fall to the firebox floor where it can be removed and disposed of.

WARNING! DO NOT OPERATE THE STOVE WITHOUT THESE BAFFLE PLATES PROPERLY INSTALLED. THIS WILL VOID WARRANTY.

In the event of a chimney fire - Make sure the fuel door is securely closed. Adjust the primary air control to the lowest (most closed) setting. Call the fire department immediately. After a chimney fire, the complete chimney system should be checked by a qualified technician before further use.

Consult your dealer for suggestions on proper chimney care. Contact your local municipal or provincial fire authority for information on how to handle a chimney fire. Have a clearly understood plan for handling a chimney fire.

REINSTALL BAFFLE PLATES

After your chimney has been swept, reinstall the baffle plates. See – *Removing Baffle Plates for Cleaning* (on this page) and reverse steps.

CLEANING BLOWER INTAKE

If an optional blower kit (catalog #14M22) is installed, the blower air intake requires cleaning at least once a year to remove lint, dust, etc. If there are pets in the dwelling, the intake should be cleaned at least twice a year.

TROUBLESHOOTING

SMOKES OUT FUEL DOOR WHEN OPEN (see ★)

1. The primary air control is closed.
2. The chimney is too cool. Set the primary air control on "HIGH" for a few minutes before opening the fuel door.
3. Excess creosote will not only restrict your draft but it will create a risk of a creosote fire. Strictly adhere to maintenance requirements as outlined in this manual. If excess creosote has built up on the inside of the firebox sides and door, burn a small hot fire at intervals that are more frequent with air control on HIGH for a few minutes.
4. Deposits may have built up in the chimney and are restricting the draft, or the spark arrester on top of the chimney may be plugged.
5. Chimney diameter too large or too small to provide adequate draft.
6. The house is too airtight (usually takes 20 to 30 minutes for problem to appear as stove lowers air pressure in house). Crack a window open or provide an outside source of air near stove.
7. Insufficient vertical height to chimney to achieve adequate draft.

DOES NOT PRODUCE ENOUGH HEAT (★)

1. Using green or insufficiently cured wood.
2. Excessive draft.
3. High ceilings (heat rises quickly, but can be recirculated by a well-placed ceiling fan with a winter/summer switch).
4. The area to heat is too large (square foot heating estimates are based on "average" climates and home design).
5. There is an obstruction in the chimney.
6. The chimney or chimney cap is restricted by creosote preventing enough draw to sustain a "high" heat output rate.

DOES NOT MAINTAIN A FIRE (★)

1. Soft wood does not burn as long or as well as seasoned hardwood resulting in a short burn time.
2. Wood size too small. Burns at too rapid a rate.
3. The gasket seal on the fuel door, ash drawer or glass is leaking air. Repair or replace it if necessary.
4. Excessive Draft.
5. There may be an obstruction in the chimney.

BACKPUFFING (★)

1. Downdraft in the chimney (a special wind cap may be needed).
2. The house is too air tight (ventilation is needed).
3. Insufficient vertical height to chimney to achieve adequate draft.

ODORS

1. Creosote accumulation in firebox (brush out on next cleaning).
2. Chimney downdraft when stove is not operating (close the primary air control).
3. Paint curing on first several burns.

DIRTY GLASS (★)

1. Poor draft conditions.
2. Long burn periods at low draft settings.
3. Burning wet, pitchy or spongy wood.
4. Poorly arranged logs (too close to glass).

★ Draft problems; If installing into a larger flue, it may be necessary to use a full length liner to achieve adequate draft for the appliance. A draft gauge should read a minimum of .05" w.c. (Inches water column) not to exceed .07" w.c. for optimum performance (See *Draft Requirements* on page 10).

OVERFIRING DAMAGE

If the heater or chimney connector glows, you are overfiring. Other symptoms may include: Cracking, warping or burning out of components, gold doors may turn color, stove glass may develop a haze, which will not come off with cleaning.

Overfiring of a stove is a condition where excessive temperatures are reached, beyond the design capabilities of the appliance. The damage that occurs from overfiring is not covered under the manufacturer's limited warranty.

The following are a few conditions that should be evaluated and (corrected if necessary) if an overfiring condition is suspected:

Overfiring Caused From Improper Installation - Ensure that all installation requirements have been met as outlined in the installation manual. The chimney should be clean and in good repair. A draft test should be performed to determine if the draft requirements of the appliance are being met. A draft gauge should read between .05 and .07 inches water column (" W.C.). Excessive draft (above .07 " W.C.) will allow too much combustion air to be pulled in which results in hotter burns. Too little draft (below .05 " W.C.) will not allow enough combustion air delivery to maintain a fire (this may result in improper operation of appliance, i.e. wont maintain fire unless fuel door or ash drawer is left open. See below, *Overfiring Caused From Improper Operation*).

Overfiring Caused From Improper Operation - Operate this appliance only as outlined in this manual. Never burn the appliance with the fuel door or ash drawer open or ajar. Do not operate this stove with the Air Control in the "open" position (pulled out) for extended periods. This wastes fuel and can cause dangerous overfiring conditions. NEVER leave the stove unattended on high settings.

Overfiring Caused From Improper Maintenance - Strictly adhere to all maintenance requirements at frequent intervals as prescribed in this manual including cleaning of flue and stove. Should the fuel door, ash drawer or glass gaskets become worn or damaged, they should be replaced.

Overfiring Caused From Improper Fuel - This appliance is approved for use with natural dry well seasoned wood only (ask your authorized dealer what are approved fuels for your area). Do not burn garbage, particleboard scraps, or pressed logs using bonding agents because they can produce conditions that will deteriorate metal. Do not overload or use kindling wood or mill ends as primary fuel as this may cause overfiring.

REPLACEMENT PARTS FOR MODEL: 1900HT-M

| PART NO. | DESCRIPTION |
|----------|--|
| CAT. NO. | |
| | Door Parts |
| G300 | Door Assembly, Gold (Handle Included) |
| 86-128 | Gasket Kit, 3/4" Door Rope (Includes Adhesive) |
| 27M81 | Gasket, Glass Channel |
| 27M66 | Clip Set, Glass |
| G400-7 | Glass, Large Arched 11x 17" (Glass gasket not included) |
| 10300 | Handle Assembly |
| 11529 | Hinge Pin 10 L 18 (Original) (Requires Welding) |
| 11531 | Hinge Pin 1/4-28 UNF (Retrofit), Requires Drill #3 (.213) & Tap |
| 10362 | Torque Plate (Latch) |
| | Component Parts |
| 1135 | Knob, Ash Drawer |
| 36025 | Panel, Top Slotted Trim (w/hole) |
| 27M80 | Gasket, Ash Drawer 1/2 X 1/8" x 16' |
| 907 | Handle, Air Control |
| 26M19 | Module, Draft Control (controls burn rate. Includes gasket) |
| 14440 | Dial - A - Temp (rheostat) |
| MS1502 | Marble Set, Gray (Also requires 1 each 1054 & 4 each 1051) |
| MS1505 | Marble Set, Green (Also requires 1 each 1054 & 4 each 1051) |
| 775002M | Installation / Operation Manual |
| | Firebox Parts (see firebrick diagram, next page) note: all firebrick are 1 1/4" thick |
| 37200 | Ash Drawer Assembly |
| 26M20 | Plate Set, Baffle |
| 37075 | Grate, Cast Iron (Requires 2) |
| 37023 | Clip W/Tab, Air Tube Retainer Rear |
| 16056 | Clip W/Tab, Air Tube Retainer Front & Middle |
| 26M21 | Tube, Secondary Air (3 each) – Tabs included |

For the location of the nearest Dealer for replacement parts, contact:

**Lennox Hearth Products
1110 West Taft Avenue
Orange, CA 92865**

COMPONENT DIAGRAMS – Model 1900HT-M

Firebrick (Note: All brick are 1 1/4" thick)

| Part/Catalog # | Quantity | Dimensions | Part/Catalog # | Quantity | Dimensions |
|----------------|----------|--------------------|----------------|----------|----------------|
| FB-1 | 10 | 9 x 4 1/2" | FB9 | 2 | 9 x 1" notched |
| FB-2 | 2 | 9 x 4 1/2" w/notch | FB11 | 2 | 4 1/2 x 4 1/2" |
| FB-3 | 2 | 9 x 4 1/2" w/hole | FB23 | 2 | 5 x 1" |
| FB7 | 4 | 9 x 2 1/8" | 37075 (grate) | 2 | 4 1/2 x 4 3/8" |

FIREBRICK DIAGRAM

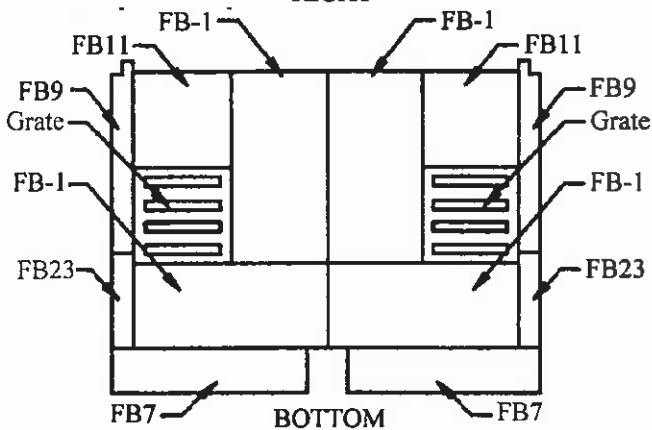
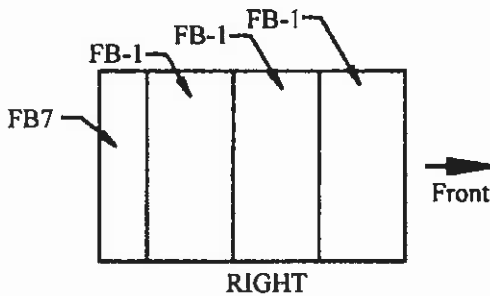
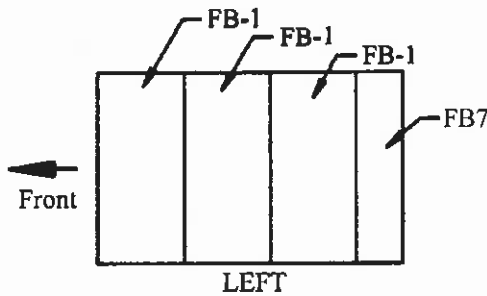
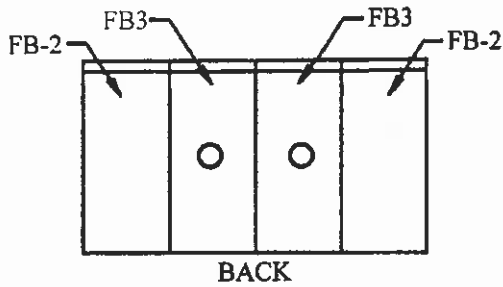

DOOR ASSEMBLY

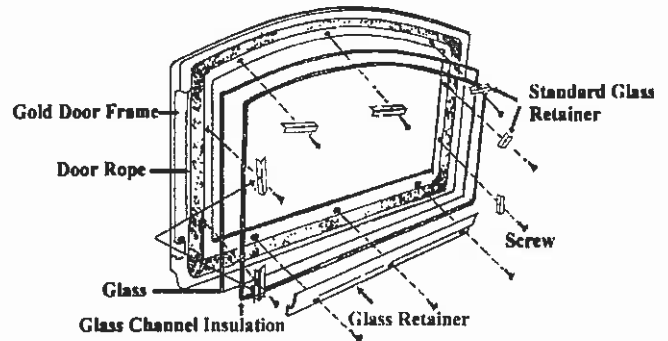

HANDLE ASSEMBLY

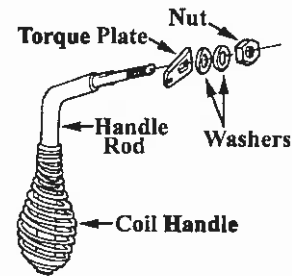

MARBLE SETS

(INSETS FOR STOVE TOP & ASHLIP)

Part/Catalog# MS1502–Gray Marble Set

Part/Catalog# MS1505–Green Marble Set

Marble is a natural product and therefore each piece will have its own unique character.

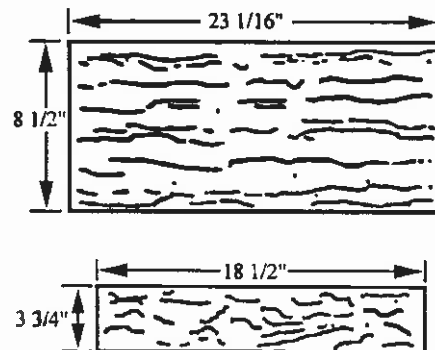

OPTIONAL ACCESSORIES- Model 1900HT-M

Note: Install and use accessories per Instructions provided with the accessory kit.

| Catalog # | Model | Description |
|-----------|--------|--|
| 14M67 | OAFD-S | Outside Air Floor Duct 5 1/4" Square |
| 14M68 | BCP-19 | Back Cover Plate |
| 14M22 | BK-100 | Blower Kit Includes Dial-A-Temp for Variable Speed Control |
| 14M21 | SSK | Stove Stat Kit Thermally Controls Blower |
| 70K99 | TSPK-B | Touch-up Spray Paint Kit, Black 12 oz Spray Can |

Outside Air Floor Duct (OAFD-S)

Outside air can be delivered for combustion air by utilizing this floor penetration duct.

(Duct penetration measures 5 1/4" square)

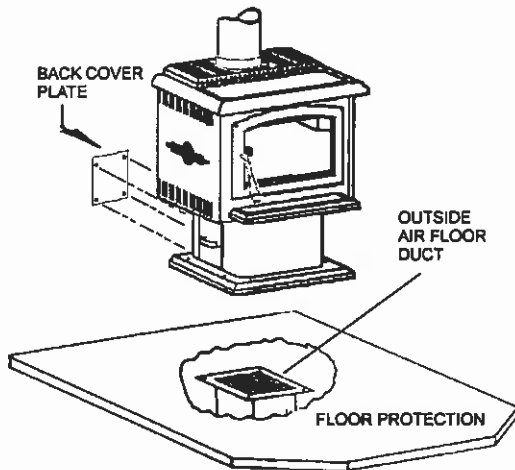

Back Cover Plate (BCP-19)

See illustration above. When using outside combustion air, the back cover plate is required to seal off the primary combustion air intake, so that it can no longer draw air from within the room.

Blower Kit (BK-100)

A Blower Kit (includes rheostat for variable speed control) is available for increased heat circulation.

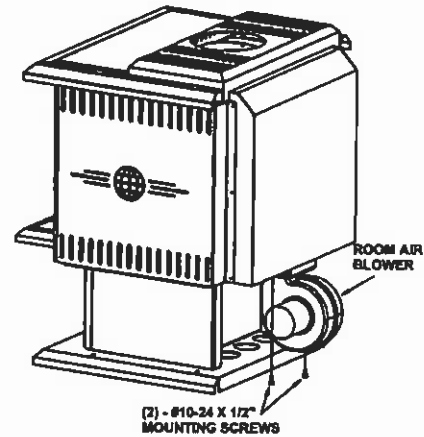

Variable Speed Control, Dial-A-Temp

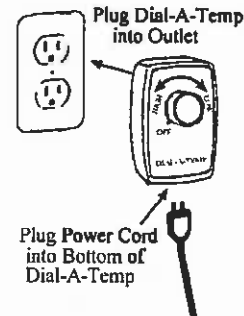

Stove-Stat Kit (SSK)

To automate the blower system an additional Stove-Stat kit can be purchased. The Stove-Stat is a heat sensor switch that will automatically turn on the blower when the stove is hot and automatically turn it off when the stove is cool.

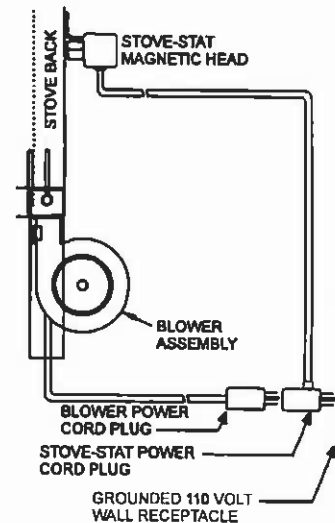

SPECIFICATIONS: Model 1900HT-M

Approximate heating capacity Up to ~2000 Sq. Ft.
 Up to 508 Sq. M

Manufactured (Mobile)

Home Approved Yes, U.S.A. Installations only.

Outside air provision Yes

Flue position Top

Flue collar size 6" (153 mm)

Approx burn time 6 to 8 hours

Maximum burn rate 61,900 BTU

EPA BTU Range 11,500-39,000 BTU

Emissions Rate (grams/hr) 2.5 grams

Efficiency 63%

Maximum Log length 18" (460 mm)

Fuel capacity 45 to 55 lbs. (20-25 kg)

Firebox Size 2 cubic feet (610 mm)

Loading Front

Width (of outer top) 27 3/4" (705 mm)

Depth 27 1/2" (699 mm)
 (stove back to ash lip front edge)

Height (to flue) 32 3/4" (832 mm)

Height (to stove top) 33 1/2" (851 mm)

Back to center line of flue 9"

Approx weight with brick 380 lbs. (173 kg)

Blower (Optional) 160 cfm

~ Square feet heating capacity and burn time are approximations only. They will vary depending upon the level of insulation, climate, house design, ceiling height, ambient outside temperatures and how the stove is operated.

Dimensions shown are approximations only
 (+/- 1/4")

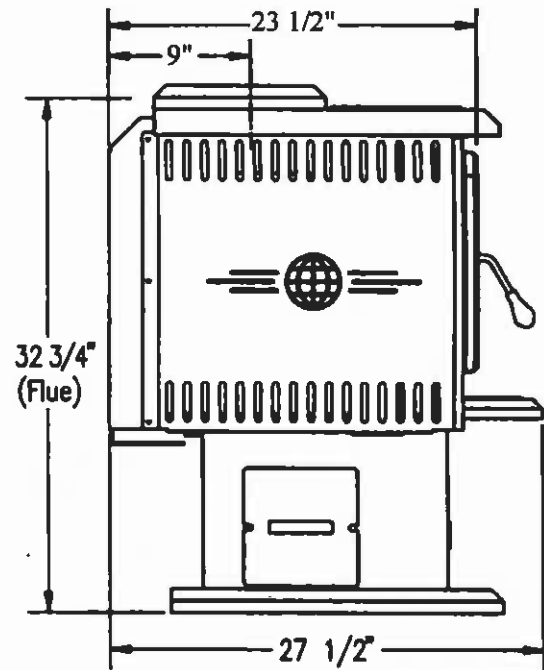
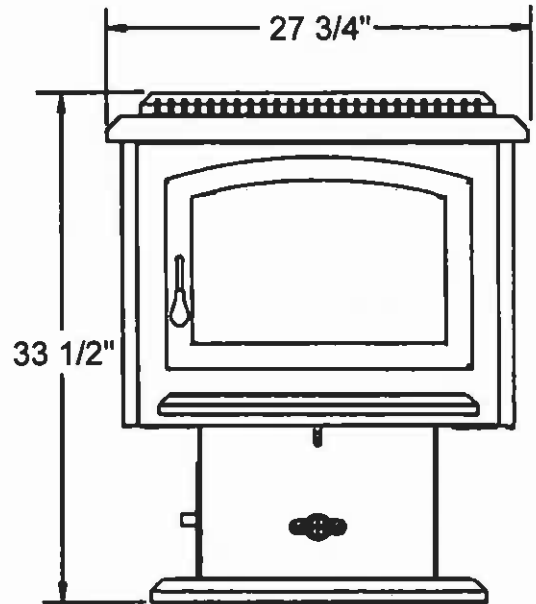

SAFETY/LISTING LABEL

CONTACT YOUR LOCAL BUILDING OR FIRE OFFICIALS ABOUT RESTRICTIONS AND INSTALLATION INSPECTION IN YOUR AREA
CONTACTEZ LE BUREAU DE LA CONSTRUCTION OU LE BUREAU DES INCENDIES AU SUJET DES RESTRICTIONS ET DES INSPECTIONS D'INSTALLATION DANS VOTRE VOISINAGE

Listed Room Heaters, Solid Fuel Type Also Suitable for Mobile Home Installation in the United States Only Pursuant to (UM)84-HUD
 Appareil de Chauffage de Pièce, de Combustibles Solides Pour Usage Pour Les Installations Dans Les Maisons Mobiles Aux États-Unis Selon (UM)84-HUD
FOR USE WITH SOLID WOOD FUEL ONLY / POUR USAGE AVEC LE BOIS SEULEMENT



Serial No. / Numéro de Série

Manufactured by / Manufacturé par:
LENNOX HEARTH PRODUCTS
 1110 West Taft Avenue
 Orange, CA 92665

Tested & Listed By Beaverton Oregon USA
 OMNI-Test Laboratories, Inc.
 Report No. / Numéro de Rapport O30-S-03-2

Model / Modèle: 1900 H.T.-M
 Tested To / Testé à: UL 1482, ULC-S627

PREVENT HOUSE FIRES

Install and use only in accordance with manufacturer's installation instructions and your local building codes.

CAUTION: Special methods are required when passing chimney through a wall or ceiling, refer to installation instructions and local building codes. Do not pass chimney connector through a combustible surface. Do not connect this unit to a chimney flue serving another appliance.

WARNING: (MOBILE HOME) An outside air inlet must be provided for combustion and be unrestricted while unit is in use.

Do not install appliance in a sleeping room.

The structural integrity of the mobile home floor, walls, and ceiling/roof must be maintained.

NOTE: Replace glass only with 5mm ceramic. Operate with the door closed.

DANGER: Risk of electrical shock. Disconnect power before servicing unit. Do not route power cord under or in front of appliance.

Electrical Rating: 115 VAC .9 Amps 60 Hz

Optional Fan Kit #14M22

PRÉVENTION DES FEUX DE MAISON

Installez et utilisez en accord avec les instructions d'installation du fabricant et des codes locaux.

AVIS: Prenez des précautions spéciales lorsque vous faites passer une cheminée à travers un mur ou un plafond, référez-vous aux instructions d'installation et aux codes locaux de la construction. Ne pas faire passer le tuyau de cheminée à travers une surface combustible. Ne pas connecter cet appareil à un tuyau de cheminée servant un autre appareil.

ATTENTION: (MAISON MOBILE) Un tuyau d'air extérieur doit être fourni pour la combustion et ne doit pas être restrictif pendant l'usage. Ne pas installer cet appareil dans une chambre à coucher. L'intégrité de la structure du plancher, des murs et des plafonds/toits doit être maintenue.

NOTE: Remplacez la vitre avec une céramique de 5mm seulement. Opérez avec la porte fermée.

DANGER: Il y a risque de décharge électrique. Déconnectez le fil électrique de la prise de contact avant le service. Ne pas faire passer le fil électrique sous ou en avant de l'appareil.

Puissance Électrique: 115 VAC .9 Amps 60 Hz

Verificateur Optionnel: #14M22

Floor protector must be non-combustible material, extending beneath heater and to the front/sides/rear as indicated.

(* In Canada)

(* See Note Below)

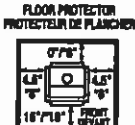
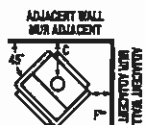
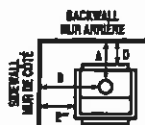

The protector of plancher doit être de matériel incombustible, s'étendant en dessous de l'appareil de chauffage et de l'avant/des côtés/et de l'arrière comme indiqué.

(* Au Canada)

(* Voir la note suivante)

| Installation | | Clearance | Chimney & Connector | Dimensions | | | | | | Installation | | Espaces Libres | Cheminée et Tuyau | Dimensions | | | | | |
|---------------------|-------------|-----------|---------------------|------------|-------|-------|-------|-------|------|-------------------|---------------|----------------|-------------------|------------|------|------|------|------|------|
| | | | | A | B | C | D | E" | F" | | | | | A | B | C | D | E" | F" |
| U.S. (in inches) | Residential | Standard | Note 1 | 21.00 | 25.00 | 18.00 | 13.75 | 15.00 | 7.75 | Canada (en cm) | Résidentielle | Standard | Note: 1 | 53.5 | 76.0 | 53.5 | 42.0 | 51.0 | 27.5 |
| | Residential | Reduced | Note: 2 | 13.00 | 25.00 | 15.00 | 6.00 | 15.00 | 5.00 | | Résidentielle | Réduite | Note: 2 | 44.5 | 76.0 | 40.5 | 25.5 | 51.0 | 15.0 |
| | Mobile Home | Standard | Note: 3 | 13.00 | 25.00 | 15.00 | 6.00 | 15.00 | 5.00 | | | | | | | | | | |

* "E" and "F" dimensions are measured to side of stove below the projection of outer top.
 Note 1: 6 inch diameter, single wall, minimum 24 MSG black or 25 MSG blue steel connector pipe with factory-built chimney listed to either UL 103HT or ULC S629.
 Note 2: 8 inch diameter listed double wall chimney connector or Type L vent pipe between the stove and chimney.
 Note 3: 6 inch diameter listed L-Vent connector pipe with UL103 HT Chimney and Mobile Home Installation Kit. Chimney must be equipped with spark arrester. See installation instructions for approved brands.

* Les dimensions "E" et "F" sont mesurées du côté du poêle en dessous de la projection extérieure du haut du poêle.
 Note 1: Le tuyau connecteur en acier noir de minimum 24 MSG ou en acier bleu de 25 MSG, de 6" de diamètre, pour mur simple, avec cheminée faite en usine, enregistrée sous ULC S-629.
 Note 2: Le tuyau connecteur de 8" de diamètre, pour mur double ou un connecteur de cheminée de type L entre le poêle et la cheminée.

CAUTION: HOT WHILE IN OPERATION. DO NOT TOUCH. CONTACT MAY CAUSE SKIN BURNS. KEEP CHILDREN, CLOTHING, FURNISHINGS AND COMBUSTIBLE MATERIAL A CONSIDERABLE DISTANCE AWAY. SEE NAMEPLATE AND INSTRUCTIONS. DO NOT OVERFIRE. IF HEATER OR CHIMNEY CONNECTOR GLOWS, YOU ARE OVERFIRING. INSPECT AND CLEAN CHIMNEY AND CONNECTOR FREQUENTLY. UNDER CERTAIN CONDITIONS OF USE, CREOSOTE BUILDUP MAY OCCUR RAPIDLY. DO NOT USE GRATE OR ELEVATE FIRE - BUILD WOOD FIRE DIRECTLY ON HEARTH. DO NOT BURN WITH FEED DOOR OR FLUE BYPASS OPEN. FEED DOOR MUST BE CLOSED DURING FIRING EXCEPT WHEN ADDING FUEL. OPEN FLUE DRAFT BEFORE OPENING FEED DOOR.
 TYPE OF FUEL: SOLID WOOD ONLY.



ATTENTION: CHAUD LORS DE L'OPÉRATION. NE PAS TOUCHER. LE CONTACT PEUT CAUSER DES BRÛLURES À LA PEAU. GARDEZ LES ENFANTS, LES VÊTEMENTS, LES MEUBLES ET LES MATÉRIEAUX COMBUSTIBLES LOIN DE L'ESPACE DESIGNÉ DE L'APAREIL. VOIR L'ÉTIQUETTE ET LES INSTRUCTIONS. NE PAS SURCHAUFFER. SI L'APPAREIL DE CHAUFFAGE OU LE TUYAU DE CHEMINÉE ROUGISSENT, VOUS SURCHAUFFEZ. INSPECTEZ ET NETTOYEZ LA CHEMINÉE ET LE TUYAU CONNECTEUR FRÉQUENTMENT. SOUS CERTAINES CONDITIONS, IL SE PEUT QUE LA CRÉOSOTE S'ACCUMULE RAPIDEMENT. N'ÉLEVEZ PAS LE FEU. BÂTISSEZ LE FEU DE BOIS DIRECTEMENT SUR L'ÂTRE. NE PAS BRÛLER LORSQUE LA PORTE D'OUVERTURE OU LA PORTE BY-PASS SONT OUVERTES. LA PORTE D'OUVERTURE DOIT ÊTRE FERMÉE PENDANT L'USAGE EXCEPTÉ PENDANT QUE VOUS AJOUTEZ DU FEU. OUVREZ LE TUYAU D'AIR AVANT D'OUVRIR LA PORTE D'OUVERTURE.
 LE TYPE DE COMBUSTIBLE: SEULEMENT DU BOIS SOLIDE

U.S. ENVIRONMENTAL PROTECTION AGENCY
 Certified to comply with July 1990 particulate emission standards.

Date of Manufacture / Date de Fabrication
 2002 2003 2004 Jan. Feb. Mar. Apr. May June July Aug. Sept. Oct. Nov. Dec.

DO NOT REMOVE THIS LABEL / NE PAS ENLEVER CETTE ÉTIQUETTE

Made in U.S.A. / Fait aux États-Unis

PN 57025 REV. F

EPA LABEL

Manufactured by: Lennox Hearth Products Model: 1P00HT-M

US ENVIRONMENTAL PROTECTION AGENCY

**MEETS EPA PARTICULATE MATTER (SMOKE) CONTROL REQUIREMENTS FOR
NONCATALYTIC WOOD HEATERS BUILT ON OR AFTER JULY 1, 1990.**

SMOKE

↓
THIS MODEL

0 (Grams Per Hour) 8.5

EFFICIENCY

↓

50% 60% 70% 80% 90% 100%

**Wood heaters with higher efficiencies cost less to operate.
(NOT TESTED FOR EFFICIENCY. THE VALUE INDICATED IS FOR SIMILAR
NONCATALYTIC WOOD HEATERS.)**

HEAT OUTPUT
10,700 to 37,400 Btu/Hr

**Use this to choose the right size appliance for your needs.
ASK DEALER FOR HELP**

**This wood heater will achieve low smoke output and high efficiency only if properly
operated and maintained. See owner's manual.**

OWNERSHIP RECORDS

Dealer's Name:

Dealer's Address:

| | | |
|-------|--------|-----------|
| City: | State: | Zip Code: |
|-------|--------|-----------|

| | | |
|----------------|-------------------|-----------------|
| Serial Number: | Date of Purchase: | Date Installed: |
|----------------|-------------------|-----------------|

Notes:

SERVICE AND MAINTENANCE LOG

| Service Date | Service Technician | Service Description |
|--------------|--------------------|---------------------|
|--------------|--------------------|---------------------|

| | | |
|--|--|--|
| | | |
|--|--|--|

| | | |
|--|--|--|
| | | |
|--|--|--|

| | | |
|--|--|--|
| | | |
|--|--|--|

| | | |
|--|--|--|
| | | |
|--|--|--|

| | | |
|--|--|--|
| | | |
|--|--|--|

| | | |
|--|--|--|
| | | |
|--|--|--|

| | | |
|--|--|--|
| | | |
|--|--|--|

| | | |
|--|--|--|
| | | |
|--|--|--|

| | | |
|--|--|--|
| | | |
|--|--|--|

| | | |
|--|--|--|
| | | |
|--|--|--|

| | | |
|--|--|--|
| | | |
|--|--|--|

| | | |
|--|--|--|
| | | |
|--|--|--|

| | | |
|--|--|--|
| | | |
|--|--|--|

| | | |
|--|--|--|
| | | |
|--|--|--|

| | | |
|--|--|--|
| | | |
|--|--|--|

| | | |
|--|--|--|
| | | |
|--|--|--|

| | | |
|--|--|--|
| | | |
|--|--|--|

| | | |
|--|--|--|
| | | |
|--|--|--|

| | | |
|--|--|--|
| | | |
|--|--|--|

LENNOX[®]

HEARTH PRODUCTS
1110 West Taft Avenue
Orange, CA 92865

