



Owner's Manual - August, 1994



WARNING: If the information in this manual is not followed exactly, a fire or explosion may result causing property damage, personal injury or loss of life.

- Do not store or use gasoline or other flammable vapors and liquids in the vicinity of this or any other appliance.
- **WHAT TO DO IF YOU SMELL GAS**
 - Do not try to light any appliance.
 - Do not touch any electrical switch; do not use any phone in your building.
 - Immediately call gas supplier from a neighbor's phone. Follow the gas supplier's instructions.
 - If you cannot reach your gas supplier, call the fire department.
- Installation and service must be performed by a qualified installer, service agency or the gas supplier.

Spirit Bay-Gas Fueled Fireplace Insert

 **Travis Industries, Inc.**
10850 117th Place N.E. Kirkland, WA 98033

Warnock Hersey
 Listed

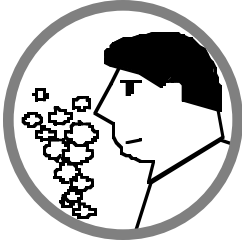

IF YOU SMELL GAS:

- * Do not light any appliance
- * Extinguish any open flame
- * Do not touch any electrical switch or plug or unplug anything
- * Open windows and vacate building
- * Call gas supplier from neighbor's house, if not reached, call fire department

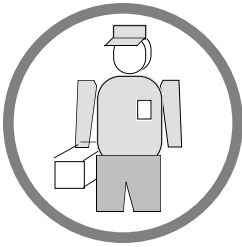

- This unit must be installed by a qualified installer to prevent the possibility of an explosion. Your dealer will know the requirements in your area and can inform you of those people considered qualified. The room heater should be inspected before use and at least annually by a qualified service person. More frequent cleaning may be required due to excessive lint from carpeting, bedding material, etc.
- The instructions in this manual must be strictly adhered to. Do not use makeshift methods or compromise in the installation. Improper installation will void the warranty and safety listing.

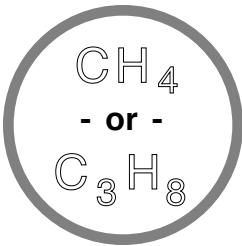

- This heater is either approved for natural gas or for LP (propane). Burning the incorrect fuel will void the warranty and safety listing and may cause an extreme safety hazard. Any questions about the type of fuel used should be directed towards your dealer.

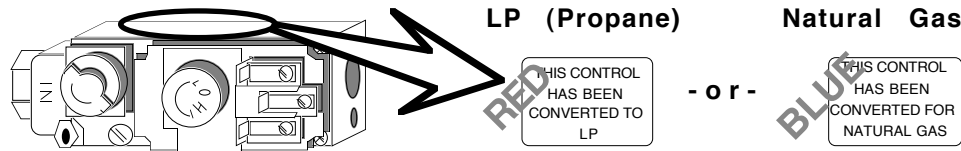

- Contact your local building officials to obtain a permit and information on any installation restrictions or inspection requirements in your area. Notify your insurance company of this heater as well.



- If the flame becomes sooty, dark orange in color, or extremely tall, do not operate the heater. Call your dealer and arrange for proper servicing.

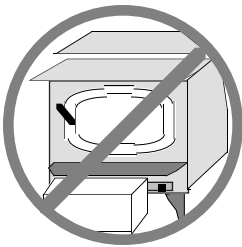

- It is imperative that control compartments, screens, or circulating air passageways of the heater be kept clean and free of obstructions. These areas provide the air necessary for safe operation.



- Do not operate the heater if it is not operating properly in any fashion or if you are uncertain. Call your dealer for a full explanation of your heater and what to expect.



- Do not store or use gasoline or other flammable liquids in the vicinity of this heater.

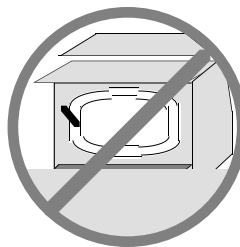

- Do not operate if any portion of the heater was submerged in water or if any corrosion occurs.



- Do not place clothing or other flammable items on or near the heater. Because this heater can be controlled by a thermostat there is a possibility of the heater turning on and igniting any items placed on or near it.



- Light the heater using the built-in piezo igniter. Do not use matches or any other external device to light your heater.

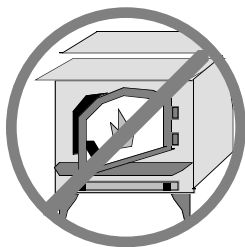

- The viewing door should be opened for service only (see the maintenance section of this manual).
- Any safety screen or guard removed for servicing must be replaced prior to operating the room heater.



- Never remove, replace, modify or substitute any part of the heater unless instructions are given in this manual. All other work must be done by a trained technician. Do not modify or replace orifices.

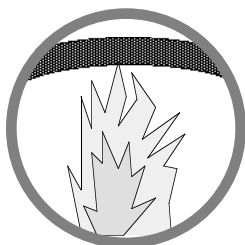

- Operate the heater according to the instructions included in this manual.
- If the main burners do not start correctly turn the gas off at the gas control valve and call your dealer for service.

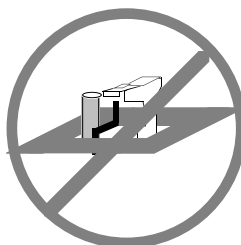

- Do not operate the heater if the pilot flame does not light – turn off the heater and call your dealer for service (see the operating instructions in this manual for lighting the pilot light if the pilot goes out).



- Do not place anything inside the firebox (except the included fiber logs).
- If the fiber logs become damaged, replace with Travis Industries fiber logs.



- Do not throw this manual away. This manual has important operating and maintenance instructions that you will need at a later time. Always follow the instructions in this manual.



- Do not touch the heater while it is hot and educate all children of the danger of a high-temperature heater. Young children should be supervised when they are in the same room as the heater.

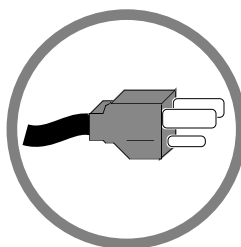

- The heater must be plugged into a 115 V. grounded electrical outlet for the blower to work correctly. Do not use an adapter plug or remove the grounding plug.
- Do not route the electrical cord in front of or over the heater.

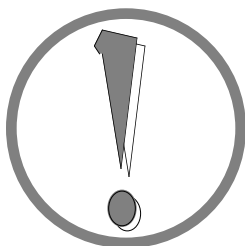

- **Travis Industries, Inc. grants no warranty, implied or stated, for the installation or maintenance of your heater, and assumes no responsibility of any consequential damage(s).**

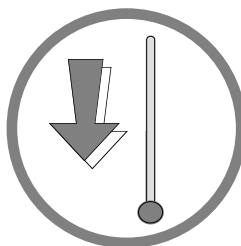

- Allow the heater to cool before carrying out any maintenance or cleaning.

General Information

Introduction & Important Information 1
Safety Precautions..... 2
Features & Specifications 5

Insert Installation

Heater Placement..... 6
Fireplace Sizing 7
Floor Protection 7
Vent Requirements..... 7
Gas Line Install..... 8
Finalizing the Installation 9

Operating Your Heater

Reviewing the Installation..... 10
Before You Begin..... 11
Location of Controls..... 11
Starting The Pilot 12
Running Your Heater 13
 Starting the Heater for the First Time 13
 Turning the Heater On and Off 14
 Adjusting the Flame Height 15
 Adjusting the Blower Speed 15
Normal Operating Sounds 15

Maintaining Your Heater

Inspecting the Firebox 16
Installing and Removing the Logs and Coals 17
Inspecting the Door 18
 Replacing the Door Gasket 18
 Replacing the Glass or Glass Gasket..... 18

Troubleshooting

Troubleshooting Table 19
How this Heater Works..... 20
 What Turns the Main Burners On and Off..... 20
 Why Nothing Should Be Placed Against the Heater..... 20
 What Prevents Gas Buildup 21
 Wiring Diagram 22
 Replacement Parts List 22

Warranty

Warranty 23

Listing Information

Listing Information 24

Optional Equipment

Surround Panel Installation 25
Telescoping Leg Installation 26
Remote Control 27
Thermostat..... 28
Re-Routing the Power Cord to the Left 30

Index

Index..... 32

Features:

- Works During Power Outages (utilizes millivolt system)
- High Efficiency; 80% for Natural Gas, 82% for LP (Steady State)
- Optional Thermostat or Remote Control
- Realistic "Wood Fire" Look
- Convenient Operating Controls
- Variable-Rate Heat Output
- Quiet Blower for Effective Heat Distribution
- Low Maintenance

Heating Specifications:

Approximate Maximum Heating Capacity (in square feet)*
 High Burn Input Rate (In BTU's)**
 Low Burn Input Rate (In BTU's)**
 AFUE Efficiency

**Spirit Bay
Natural Gas**
 900 - 1,500
 31,000
 18,000
 70.0%

**Spirit Bay
LP (propane)**
 900 - 1,500
 31,000
 17,000
 70.0%

- * Heating capacity will vary depending on the home's floor plan, degree of insulation, and the outside temperature. It is also affected by the natural gas or LP BTU rating.
- ** To measure the net BTU's, multiply the BTU input by the efficiency percentage (80% for natural gas, 82% for LP).

Spirit Bay Dimensions

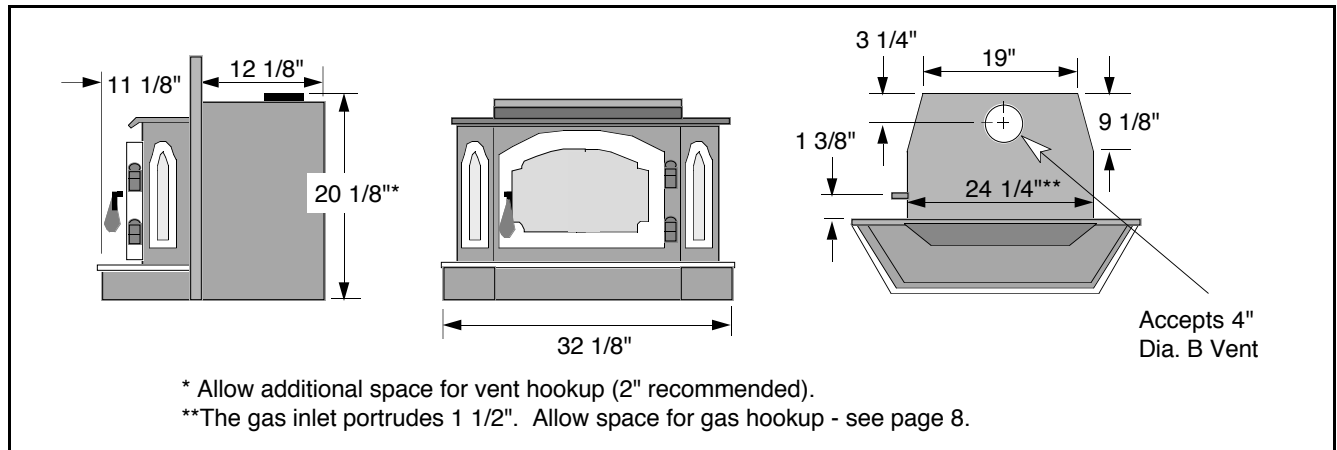

Weight = 200 Pounds

Electrical Specifications:

Blower Electrical Rating:..... 115 Volts, 1.3 Amps, 60 Hz (150 watts on high)

Fuel:

The heater is designed either for natural gas or for propane (but not for both). Check the sticker on the top of the gas control valve.

Emissions:

This unit has passed the ANSI emission standards for vented room heaters as tested by Warnock Hersey, LTD.

This appliance must be installed in accordance with all local codes, if any; if not, follow ANSI Z223.1 and the requirements listed in this manual. Failure to follow all of the requirements may result in property damage, bodily injury, or even death.

Check with local building officials for any permits required for installation of this gas heater and notify your insurance company before hooking up this heater. The requirements listed below are divided into sections. All requirements must be met simultaneously. The order of installation is not rigid – the qualified installer should follow the procedure best suited for the installation.

Heater Placement

The heater may be installed in a masonry or zero-clearance (metal) fireplace with the following requirements:

- The insert must be placed so that no combustibles are within, or can swing within (e.g. drapes, doors), 36" of the front of the heater
- The insert must be installed in a level, undamaged masonry or zero-clearance (metal) fireplace. Any damage must be repaired prior to installation. The heater must not extend beyond the hearth.
- The insert must maintain a 10" clearance to combustible sidewalls
- The non-combustible side facing (e.g. brick, tile, cement board) must extend 8" from the side of the insert
- The non-combustible top facing (e.g. brick, tile, cement board) must extend 8" above the top of the insert
- Combustible mantles must be at least 17 1/2" above the top of the insert



HINT: REDUCING CLEARANCES - Clearances may be reduced by methods specified in NFPA 211, listed wall shields, pipe shields, or other means approved by local building or fire officials.

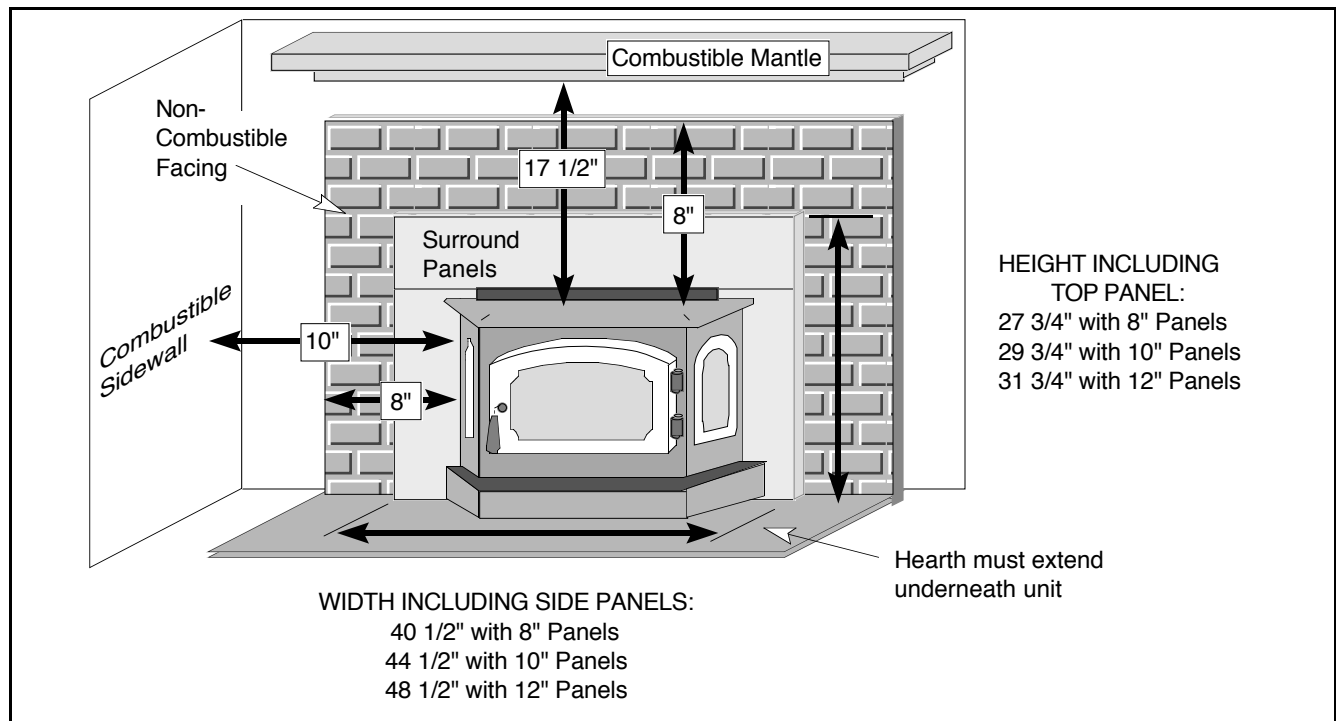

Floor Protection

Install the heater over a non-combustible hearth that extends the full width and depth of the unit. The hearth must be 32 1/8" wide by 11 1/8" deep (see the illustration on the following page).

Fireplace Sizing

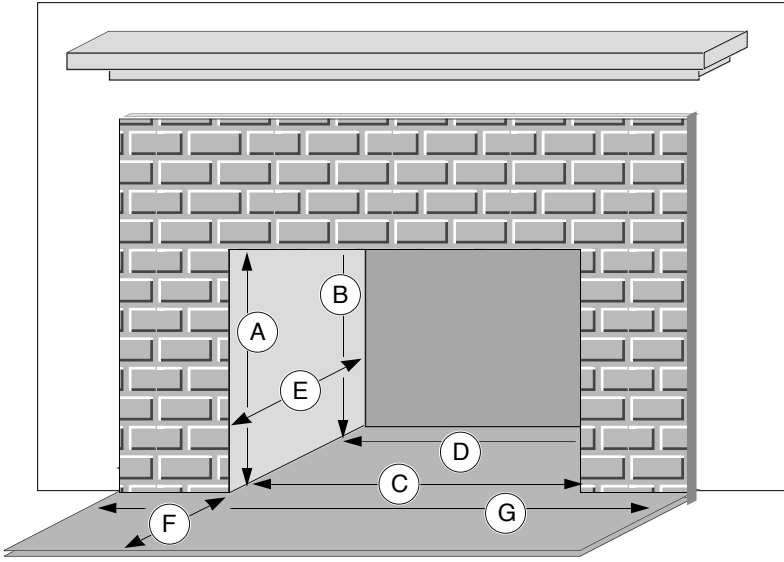

Minimum Fireplace Size

| | |
|------------------|------------|
| A Height (front) | 21"* |
| B Height (rear) | 21"* |
| C Width (front) | 24 1/4"*** |
| D Width (rear) | 19" |
| E Depth | 12 1/8" |
| F Hearth Depth | 11 1/8" |
| G Hearth Width | 32 1/8" |

* Allow space for vent hookup. An additional 2" is recommended.

** The gas inlet exits the heater on the left side. It protrudes 1 1/2" and the center is 1 3/8" back from the fireplace opening. Allow space for gas hookup.

Vent Requirements

The vent must be installed in accordance with all local codes, if any; if not, follow ANSI 223.1 and the requirements listed below. Furthermore, the vent must be installed to meet the installation requirements of the vent manufacturer.

- Minimum 5' vertical rise from top of stove (see the illustration below)
- 4" listed gas chimney liner or B vent from one manufacturer (don't mix brands)
- Vent must reline the entire length of the chimney
- The vent must not service another appliance
- Must meet all of the vent manufacturer's requirements

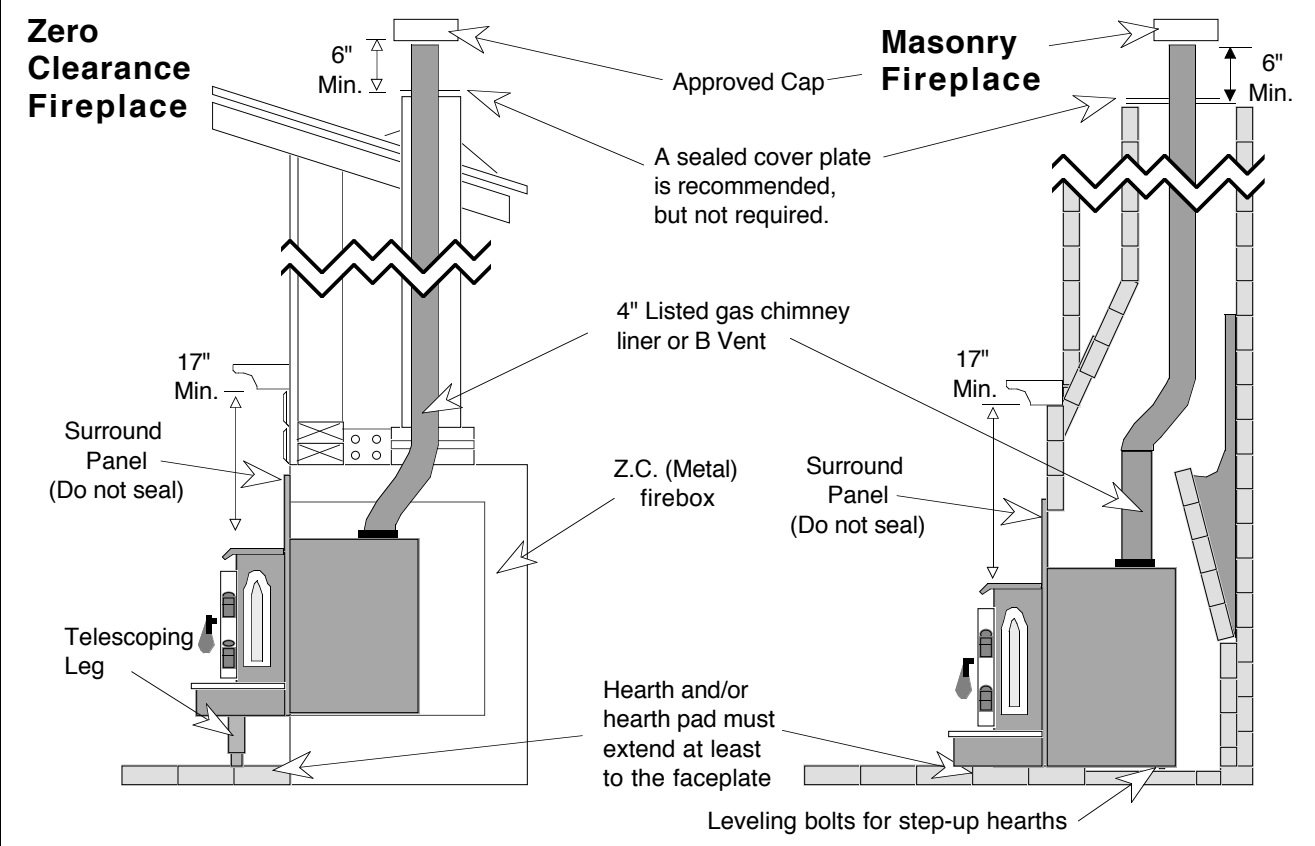

Zero Clearance Fireplace

Masonry Fireplace

Labels and dimensions:

- Approved Cap
- A sealed cover plate is recommended, but not required.
- 4" Listed gas chimney liner or B Vent
- Surround Panel (Do not seal)
- Z.C. (Metal) firebox
- Telescoping Leg
- Hearth and/or hearth pad must extend at least to the faceplate
- Leveling bolts for step-up hearths
- 6" Min. clearance
- 17" Min. clearance

Vent Requirements (continued)



NOTE: When using flexible gas vent, do not crimp or rupture the liner when bending it around a chimney offset

The vent termination must meet the following requirements:

- Vent termination must have an approved cap (to prevent water from entering)
- Vent termination must not be located where it will become plugged by snow or other material
- Vent termination must extend a minimum of 6" above the top of the chimney



NOTE: When installed, the vent must provide suitable draft for the appliance. Other factors, such as exhaust fans, may create negative pressure inside the home and cause down drafts. Additional vent height may be required in these circumstances.

How to tell if you have negative pressure:

The most common indication of a negative pressure situation is the heater (and pilot) turning off between 10 and 25 minutes from the time the main burner was started (this happens most often on cold days). The main burner turns on, but instead of warming the flue and creating draft, it vents out of the draft hood at the rear of the heater. The spill switch then heats up, and in about 5 to 15 minutes shuts off all gas to the heater (shutting off the main burner and pilot). If a thermostat is used on your heater, and the pilot shuts down sporadically, you may have a negative pressure situation.

Gas Line Install

The gas line must be installed in accordance with all local codes, if any; if not, follow ANSI 223.1 and the requirements listed below.

Gas Line Connection:

- The gas inlet is a male 3/8" NPT
- This appliance requires a shutoff valve upstream of the appliance. This valve must be accessible and within 3 feet of the heater.

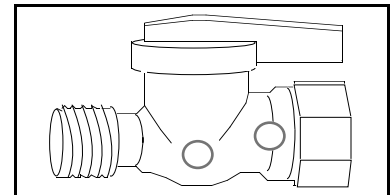

Gas Inlet Location:

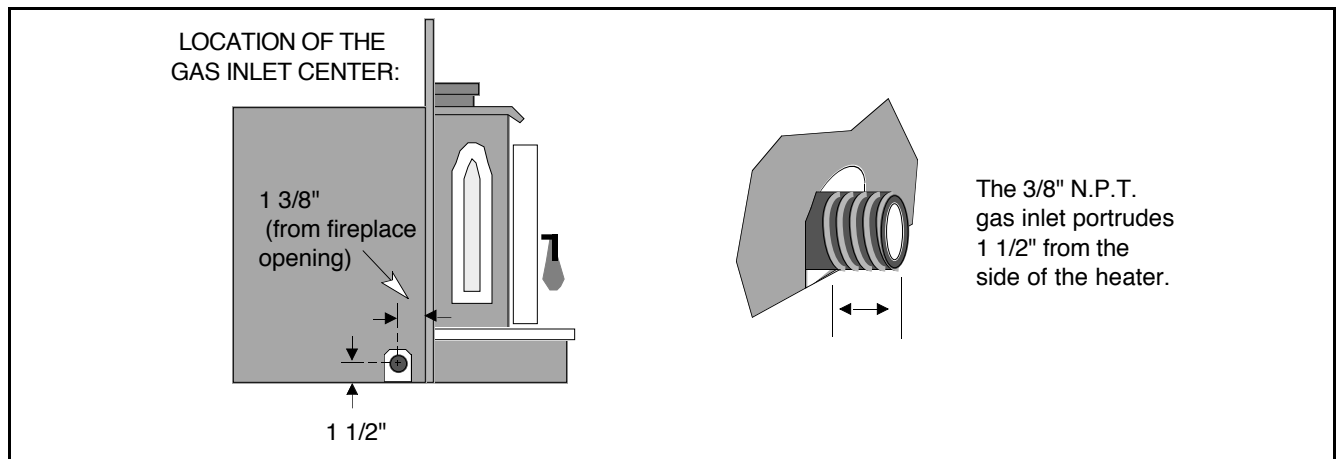

Manifold Pressure:

- Check the pressure of the gas downstream of the valve by removing the manifold pressure tap with a 3/16" allen wrench (1/8" N.P.T. plug). If the manifold pressure does not match the pressure listed in the table below, check the inlet gas pressure and correct the problem.

| Manifold Pressure with Regulator on HI | |
|---|-----------|
| Natural Gas | 3.5" W.C. |
| Propane | 11" W.C. |

WARNING: The heater must be turned off while connecting or disconnecting the pressure tap or pressure sensing device. Gas will ignite through the pressure tap hole if the heater is on and the pressure tap hole is open!

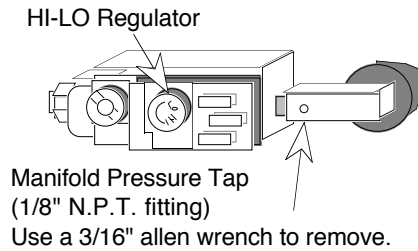

Gas Pressure:

| Minimum Input Pressure | |
|-------------------------------|-----------|
| Natural Gas | 5.5" W.C. |
| Propane | 11" W.C. |

- If the pressure is not sufficient, make sure the piping used is large enough, the supply regulator is adequately adjusted, and the total gas load for the residence does not exceed the amount supplied.
- The supply regulator (the regulator that attaches directly to the residence inlet or to the propane tank) should supply gas at the suggested input pressure listed above. Contact the local gas supplier if the regulator is at an improper pressure.

Purging the Gas Line:

The gas line must be properly purged to release all air in the gas line prior to starting the heater.

Finalizing the Installation

- Before starting, all gas line joints must be leak tested.
- Optional equipment must be installed (instructions are in the rear of this manual).
- The ceramic logs must be placed inside the firebox (see the section "Installing the Logs and Coals" in the maintenance section of this manual).
- Start the heater and check for proper performance. Review the operations portion of this manual to make sure the owner understands the operation of the heater.

Note: See the instructions "Re-Routing the Power Cord to the Left or Rear of the Heater" in the optional equipment section of this manual to re-route the power cord.

The check off list below details the installation concerns that you, the consumer, should know prior to starting the heater. This information is very important and must be checked off.

- () There are no combustible items placed within 36" of the front of the heater or swing within 36" of the front of heater. This includes furniture, doors, drapes, etc.

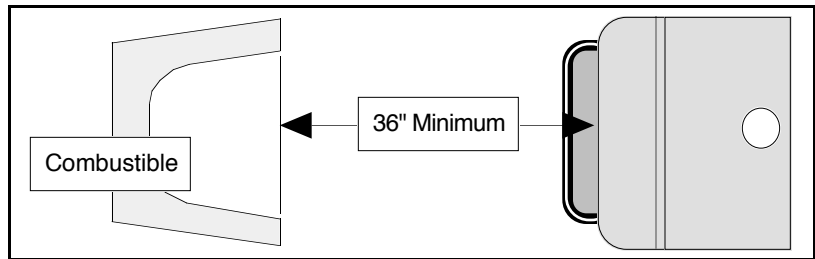

- () No combustibles are within 1" of the exhaust vent. Due to high temperatures, the room heater should be located out of traffic and away from combustibles. This includes drywall, drapes, window sills, etc. If any question exists, call your dealer for a full explanation.

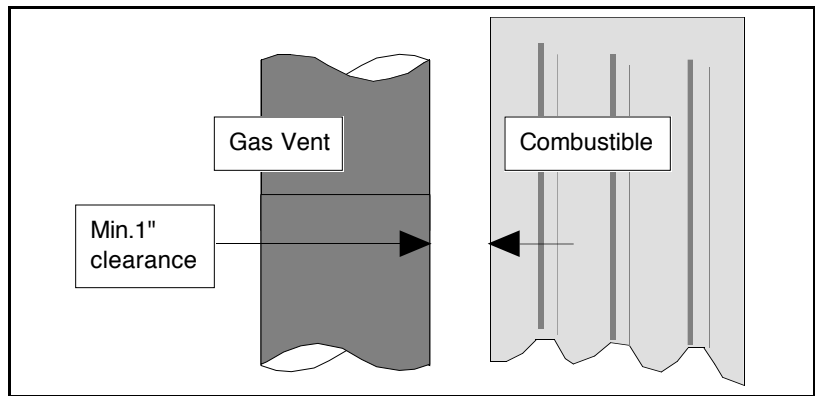

- () The location of the GAS MAIN SHUTOFF VALVE. It is usually directly next to the gas meter or propane tank and may require a wrench to shut off. Everyone in the house should know where the gas main shutoff valve is and how to turn it off.

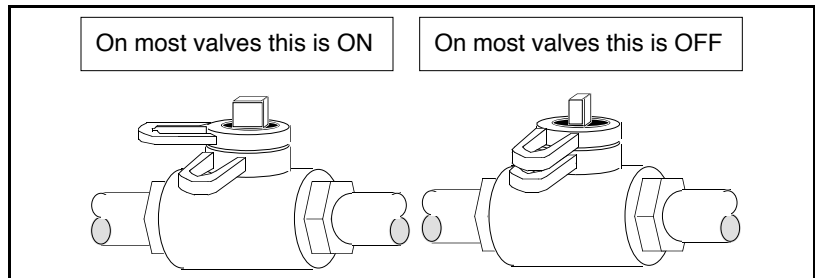

- () All of the necessary permits and installation information have been obtained for your records. This includes the permits from building officials, receipts, and this manual.

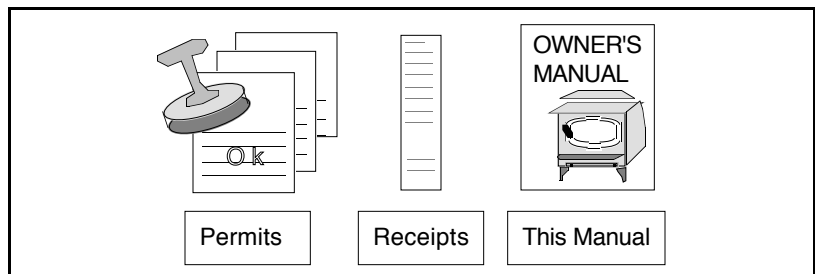

- () The operation card included with the heater slides out from behind the access panel. If you can not find it, call your dealer for details. This card includes important operation information that must be kept with the heater at all times.

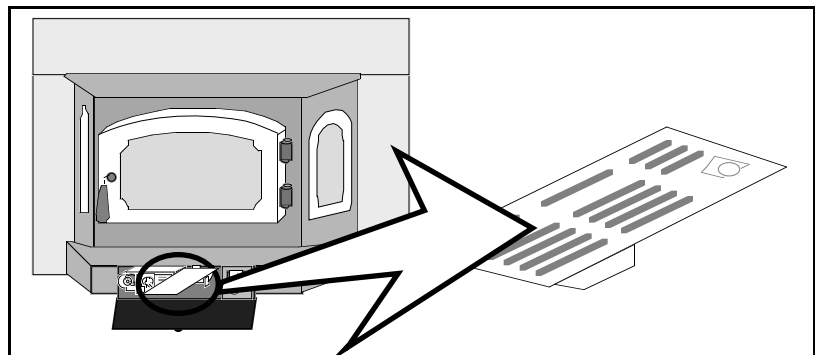

Before You Begin

READ THIS ENTIRE MANUAL BEFORE YOU USE YOUR NEW HEATER. FAILURE TO FOLLOW THE INSTRUCTIONS MAY RESULT IN PROPERTY DAMAGE, BODILY INJURY, OR EVEN DEATH.

Before starting your heater make sure you have read the section titled **Safety Precautions**. Any questions should be referred to your dealer.

Location of Controls - See explanation below

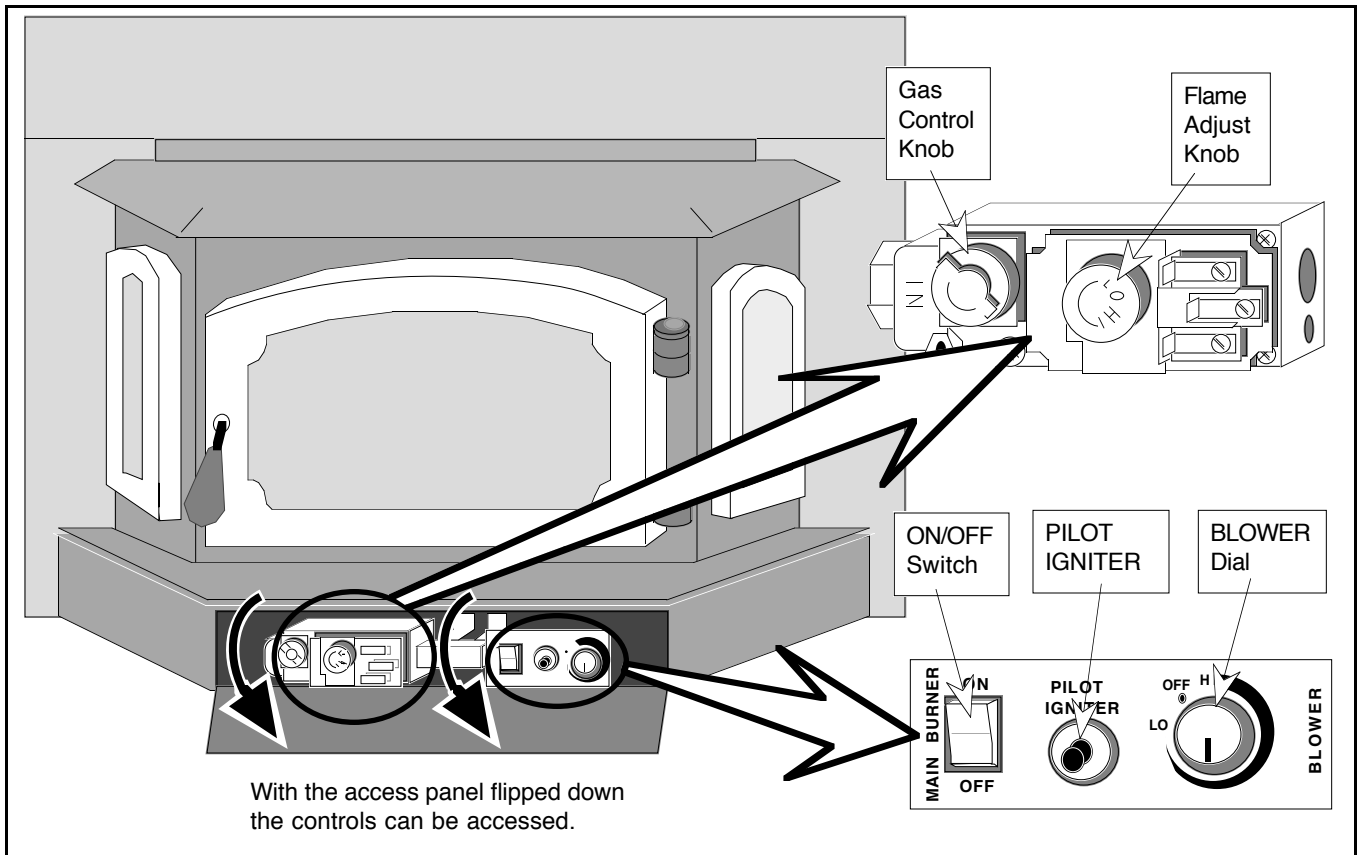

Gas Control Knob

This knob is used for starting the pilot. There are three positions, ON, OFF, & PILOT. The pointer directly below the knob indicates the position this knob is in.

Flame Adjust Knob

This knob controls the flame height from low ("LO") to high ("HI"). The pointer to the upper right of the knob points to the position this knob is in.

ON/OFF Switch

This control is used to turn the heater on and off.

PILOT IGNITER

The pilot igniter is used only while starting the pilot. When pressed, it sends an electrical charge to the pilot assembly. This creates a blue spark directly next to the pilot light, igniting it.

BLOWER Dial

This dial controls the speed of the internal convection blower that pushes the heated air into the room.



NOTE:

The ON/OFF Switch must be left "ON" if using the remote control or thermostat. Turning the ON/OFF Switch to "OFF" will keep the heater off always.

Starting The Pilot

The pilot light is used to ignite the main burners when the stove is turned on and also provides an important safety role. It will stay lit once it is started. However, the gas flowing to the pilot will shut off whenever the pilot goes out. If the pilot turns off frequently, call your dealer for information. To start the pilot follow the directions below:

- A. Push the gas control knob in slightly and turn it to the "OFF" position. The knob will not turn from "ON" to "OFF" unless the knob is depressed slightly.

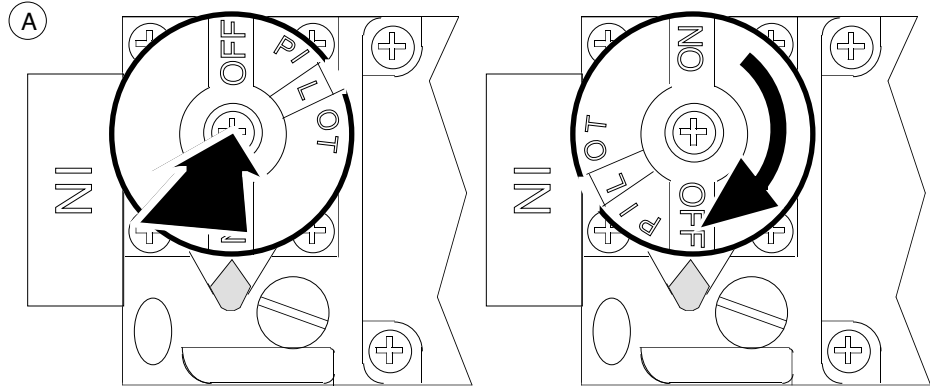

- B. Wait five minutes to let any gas that may have accumulated inside the firebox escape. If you smell gas, follow the directions on the cover "IF YOU SMELL GAS".

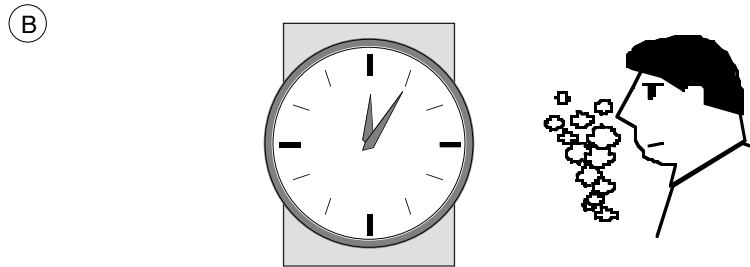

- C. Turn the gas control knob to the "PILOT" position and press the knob in, this will allow gas to flow to the pilot light. Press the red button on the pilot igniter repeatedly until you see the pilot light. **KEEP THE GAS CONTROL KNOB DEPRESSED FOR 30 SECONDS ONCE IT IS LIT.** Note: If the pilot does not light after several tries, call your dealer for service.

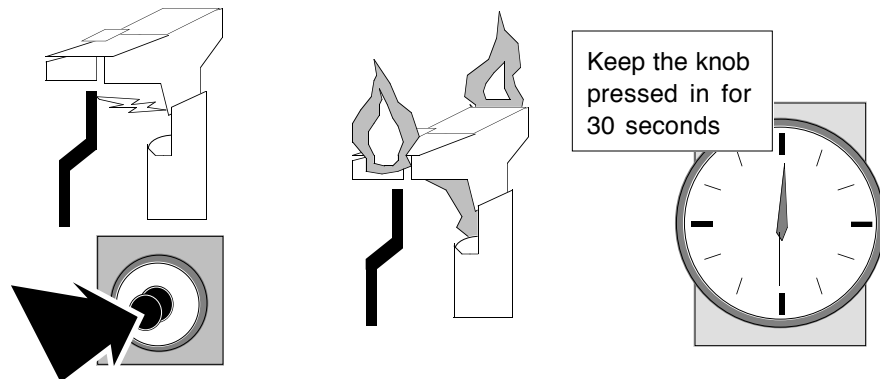
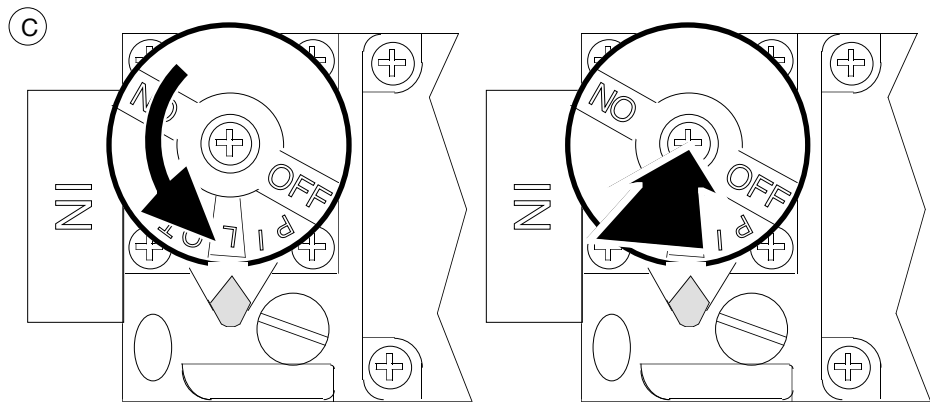

- D. Release the gas control knob. If the pilot goes out, repeat step C. If the pilot refuses to stay lit, call your dealer for service.

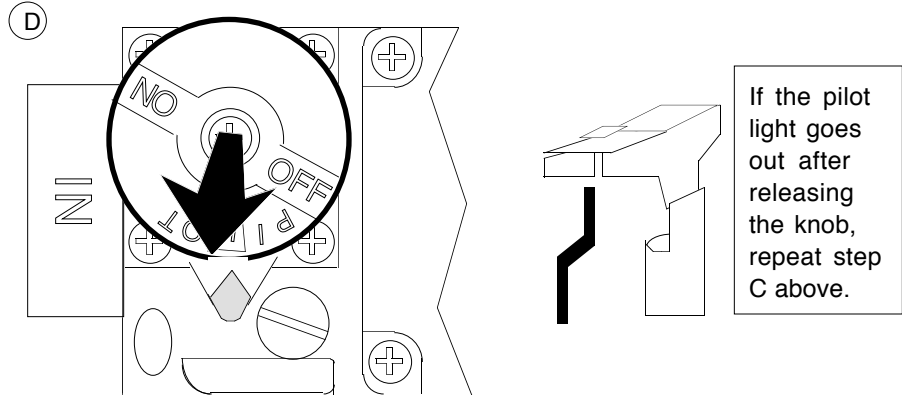

- E. Turn the gas control knob counter-clockwise to "ON". The pilot is now lit and the heater can be turned on and off.

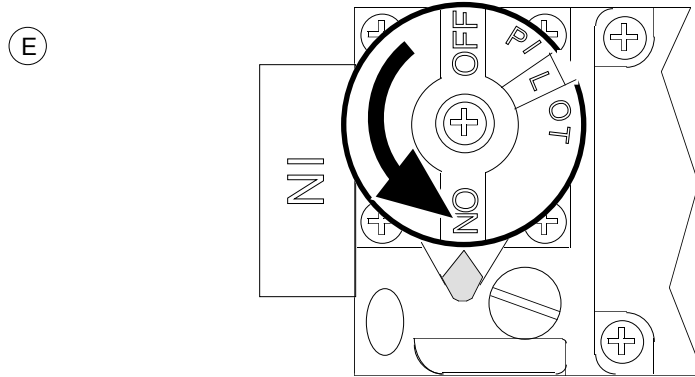

Running Your Heater

Your heater may be turned on and off manually, with the optional remote control, or by the optional thermostat. The speed of the blower and the height of the flame can also be adjusted manually.



NOTE:

When the heater first comes on, the flames will be blue and somewhat transparent. After fifteen minutes the flames will turn a more realistic yellow and orange color.

NOTE:

Certain installations use a remote "wall switch" to turn the heater on and off. If this is the case, leave the ON/OFF switch on "ON".

NOTE:

When this switch is turned to the "OFF" position the main burner will not operate. However, the pilot flame will stay lit.

Starting the Heater for the First Time

Cure the Paint

To cure the paint, start the heater and turn the flame height to low. Leave it on for 20 minutes then turn it off and let it cool. Repeat this process two more times to fully cure the paint. You will smell the paint curing – this is normal.

Ventilate the Room

You may wish to ventilate the room by opening a window. Furthermore, the glass may become obscure during the first 10 hours of burning due to the components inside the firebox curing. Clean the glass with a glass cleaner after the first ten hours of operation.

Turning the Heater On and Off

• **Manual Operation**

After the pilot has been on for approximately one minute the heater may be turned on and off by pressing the ON/OFF switch located behind the access panel underneath the ashlip (see the illustration to the right).

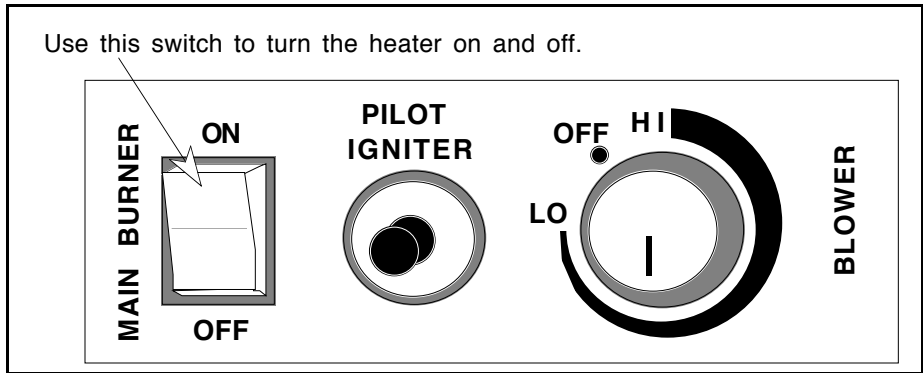

• **Remote Control Operation (Optional)**

The remote control turns the heater on from any location within the room. It utilizes a remote control and a receiver (usually located in the wall near the heater). Make sure the following has been done before trying to use the remote control: 1) The pilot is on; 2) The on/off switch is turned to "ON", and; 3) The switch on the remote control receiver is turned to "REMOTE" (see the illustration below). This switch can also be used to turn the heater on and off manually. The remote control requires two batteries, one in the remote and one in the remote control receiver. Both batteries must be charged for the remote control to work. If the remote control does not work, try replacing the batteries. If this doesn't work, contact your dealer for service.

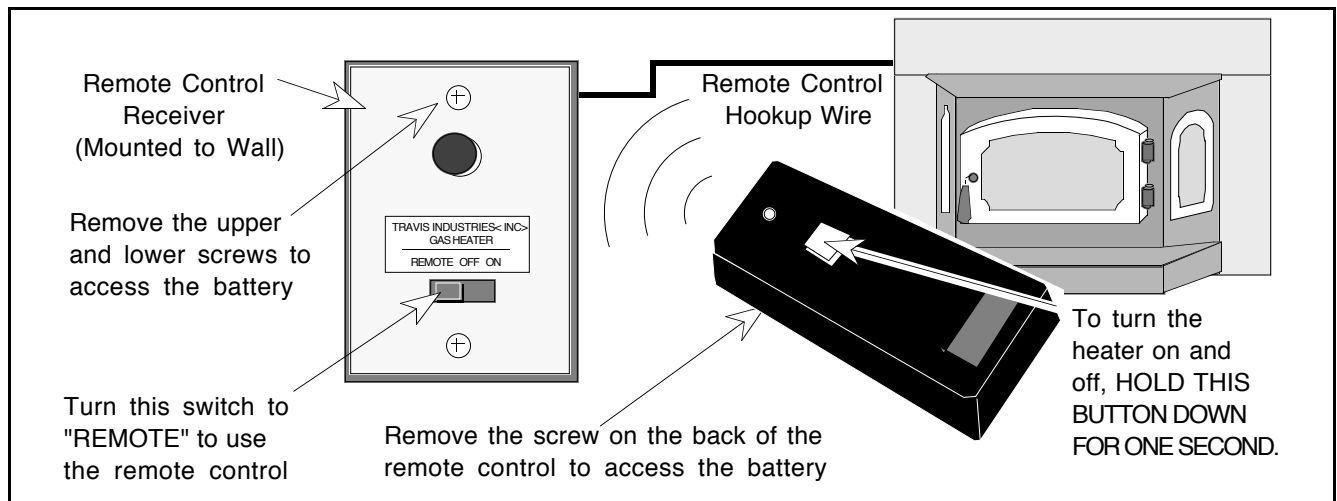

• **Thermostat Operation (Optional)**

After the pilot has been started the heater may be controlled by a thermostat. The on/off switch on the heater must be turned "ON" for the thermostat to operate. The thermostat will automatically turn the heater on and off depending on the temperature. If the thermostat does not turn the heater on, the thermostat may be set too low or the on/off switch may be turned "OFF". If the thermostat does not turn the heater off, the thermostat may be set too high. If the thermostat does not work after making these adjustments, call your dealer for service.

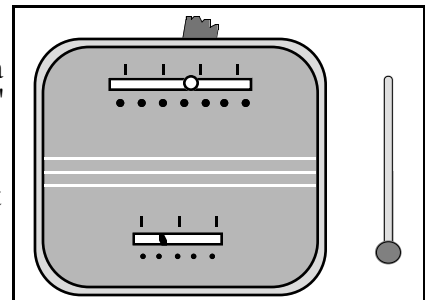

HINT: If the heater turns on and off frequently, you may want to adjust the flame height down until it produces just enough heat needed. This keeps the thermostat from turning the heater on and off repeatedly.



WARNING: Do not place any combustible items on top of the heater, even temporarily. The thermostat is automatic and may start the heater causing a combustible item to ignite.

Adjusting the Flame Height

Your heater has an adjustable flame to tailor the look and heat output to your specific needs. It is adjusted by turning the middle dial on the valve assembly.

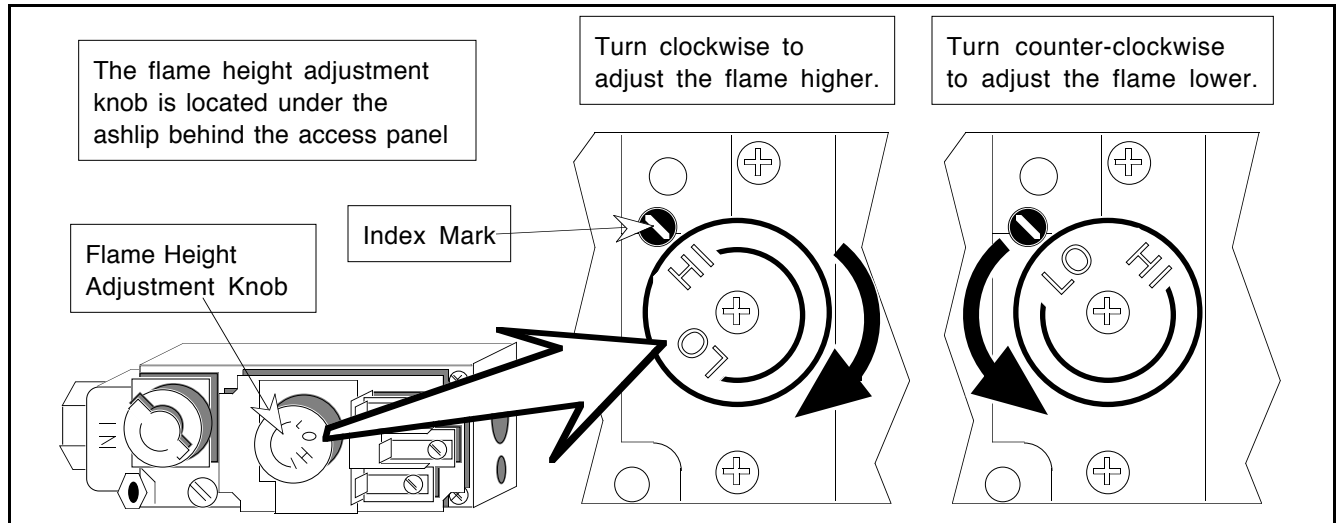

Adjusting the Blower Speed

The blower helps transfer the heat from the heater into the room. It will not turn on until the heater is up to temperature (approximately 10 minutes after starting). See the illustration below for instructions on adjusting the blower speed.

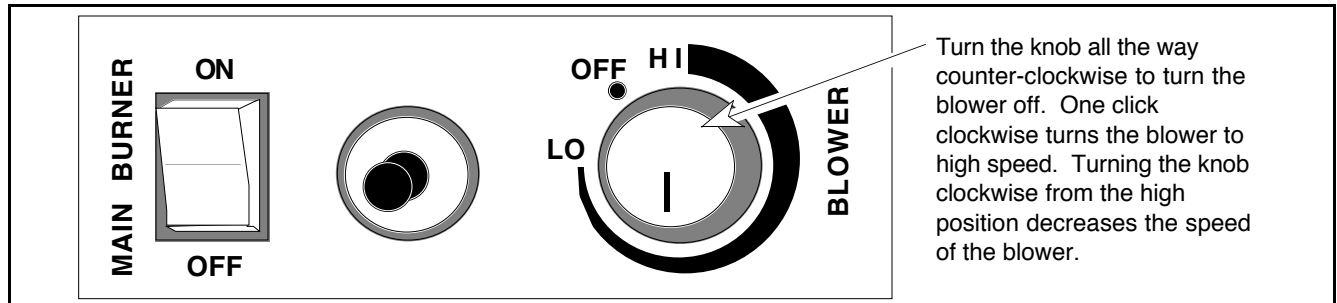

Normal Operating Sounds

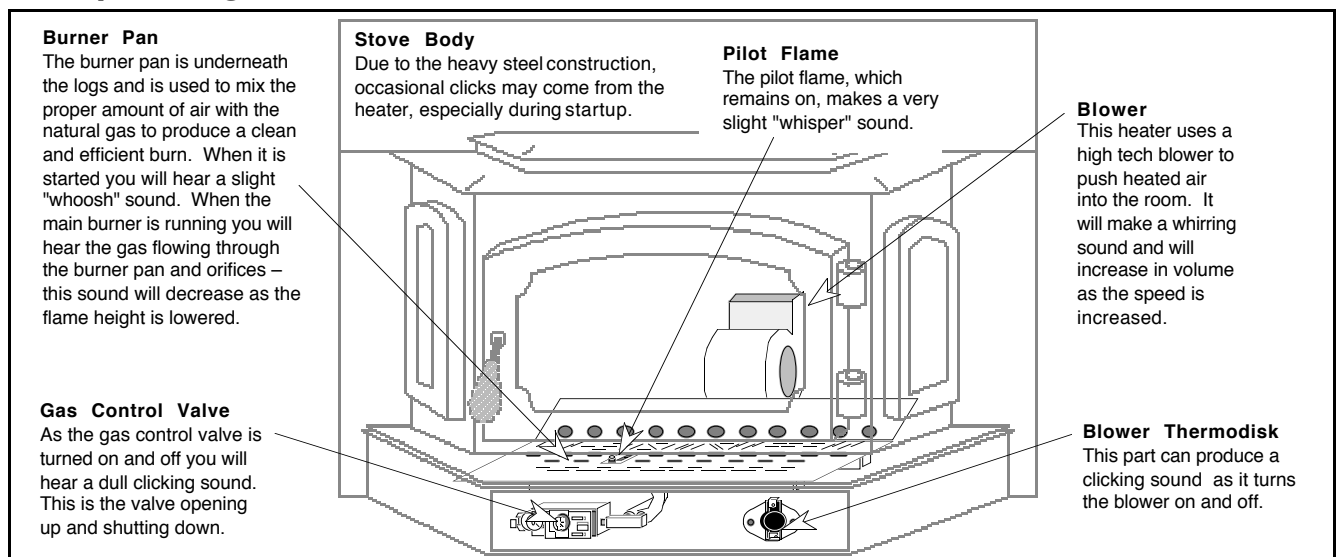

Every year you should inspect the firebox and door to make sure they are clean and functional.



WARNING: Failure to inspect and maintain your heater may lead to improper burning inside the heater, leading to a dangerous situation.

Inspecting the Firebox

The firebox should be inspected and cleaned of any soot or dust that may have been drawn into the heater. To do this, follow the directions below.

1. Remove the door (see the illustration below).

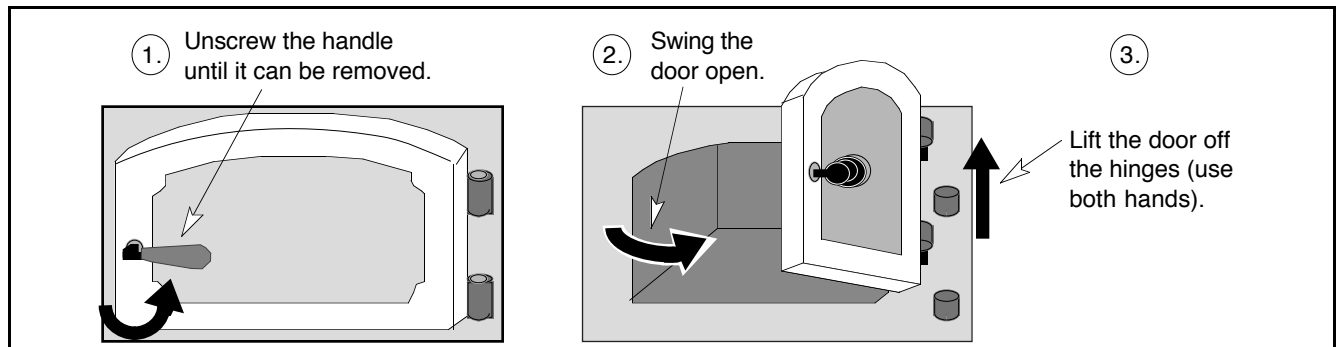

2. Remove the logs and coals (see the instructions on the following page).
3. Use a vacuum cleaner with a soft brush attachment to vacuum any dirt off the burner pan (see the illustration below). The rear log is fragile and should not be vacuumed. Inspect the burner pan and firebox for any deterioration. If it shows signs of deterioration, call your dealer for a full inspection. There should be no soot in the firebox, except for a small amount on the logs where the flames brush up against them. If there is additional soot, the heater may need adjustment. Contact your dealer for information.

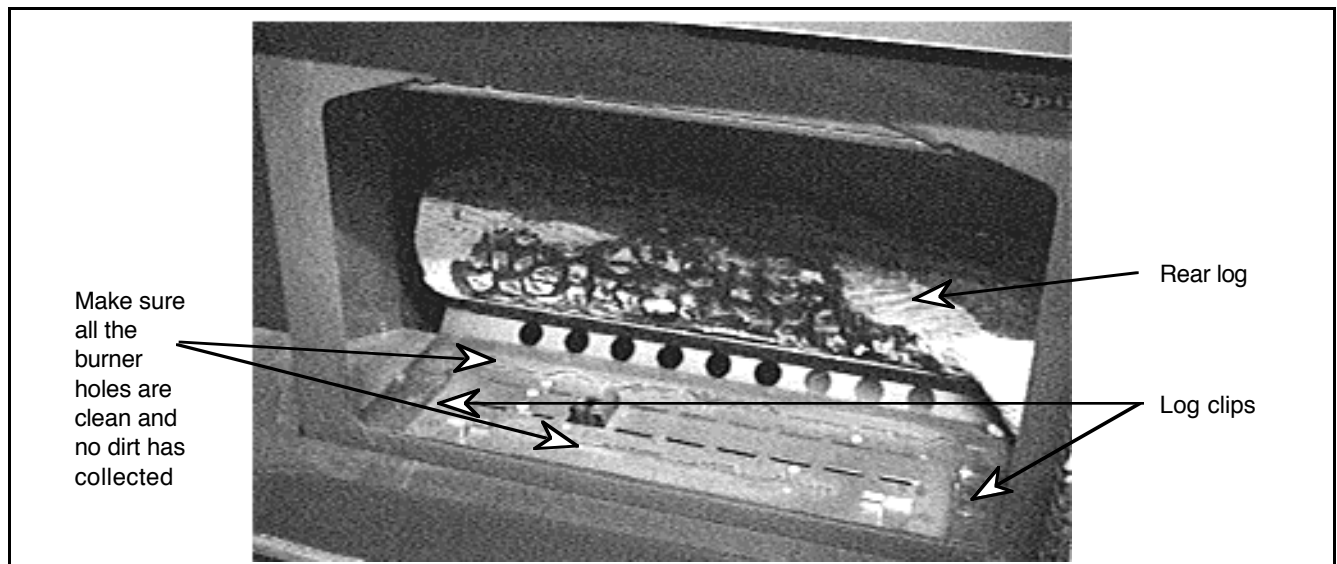

4. To replace the front log and coals follow the directions in the section "Installing the Logs and Coals".
5. Replace the door. Turn the door handle clockwise until the door seals tight with door handle facing downward.

Installing and Removing the Logs and Coals

NOTE: If the logs are not installed properly, the heater will not burn properly.

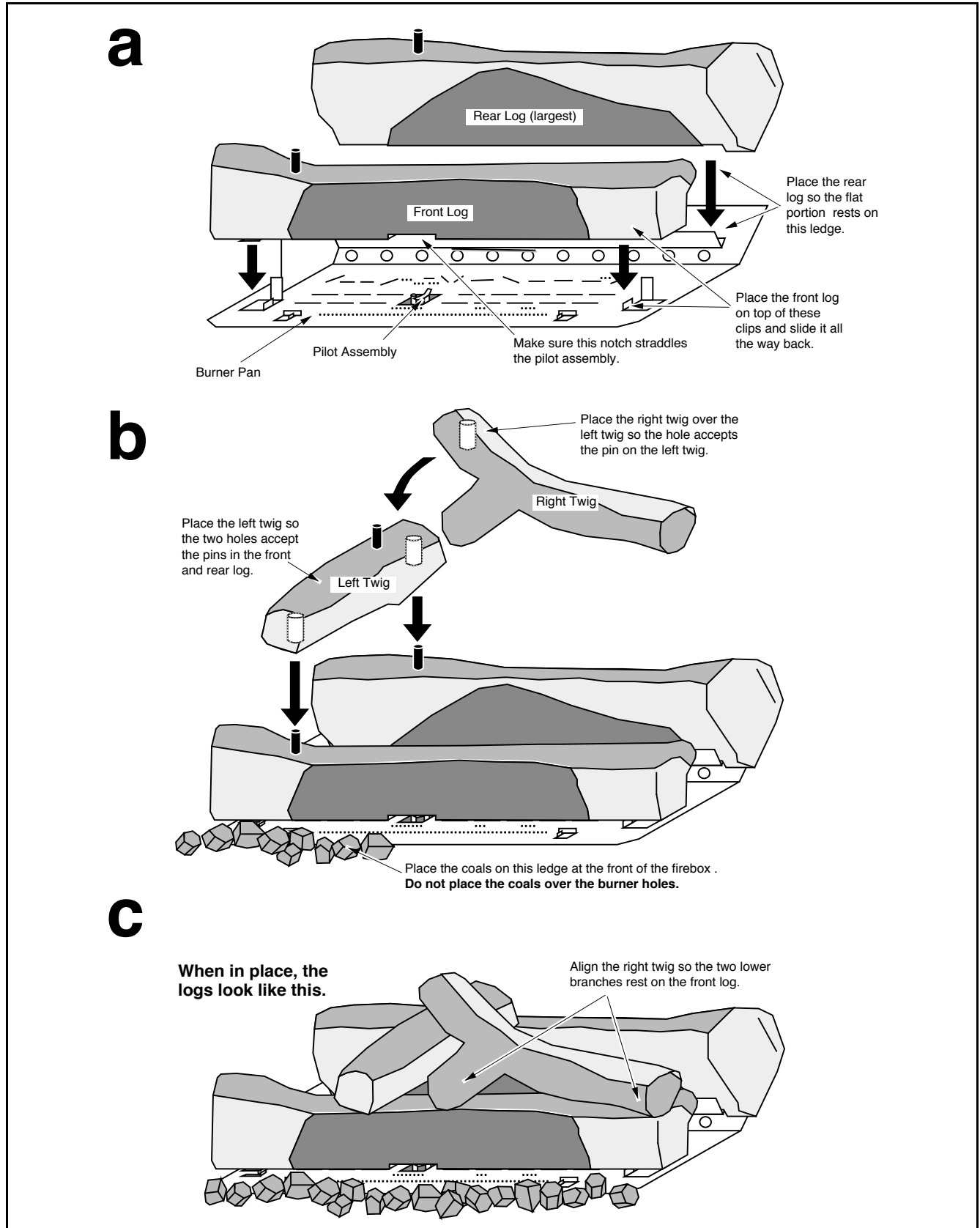

Inspecting the Door

The door must seal against the door seal for your heater to operate correctly.

1. Remove the door (follow the directions under "Inspecting the Firebox").
2. Place the door face down and check the items below. If the gaskets or glass require replacing, follow the instructions below.

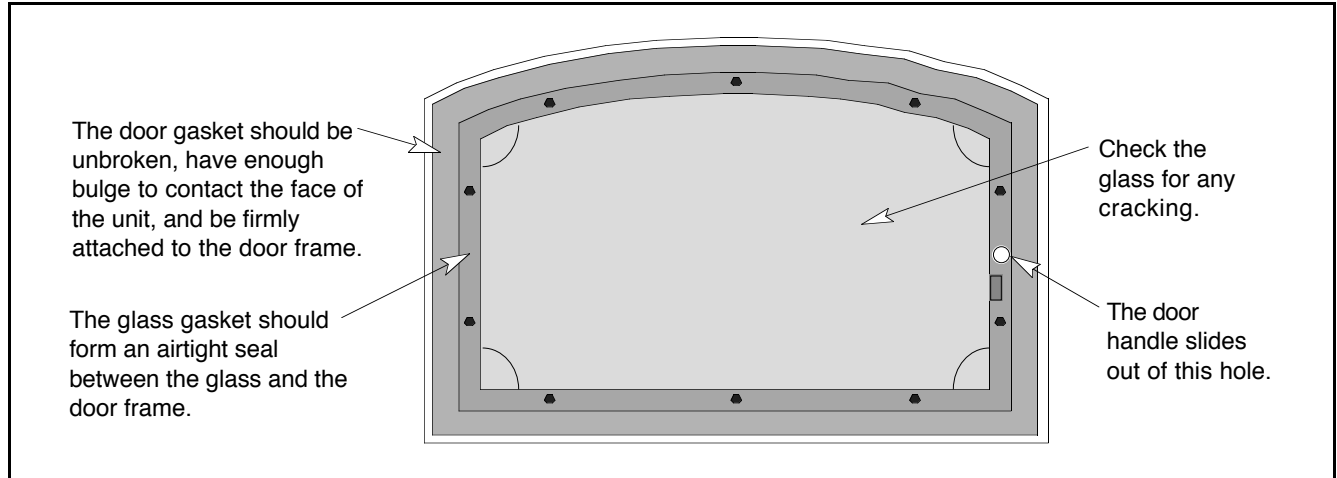

3. Then replace the door. Turn the door handle clockwise until the door seals tight. Tighten the handle until it points downward.

Replacing the Door Gasket

Remove the old gasket (use a screwdriver if necessary - see the illustration below). Apply a line of gasket cement (available from your dealer) in the groove that follows the perimeter of the door. Insert the gasket into the groove. Do not stretch the gasket as you place it into the groove. Cut off any excess gasket when done. Allow 2 hours for the cement to dry. When re-installing the door, the gasket may need to be flattened by repeatedly opening and closing the door firmly.

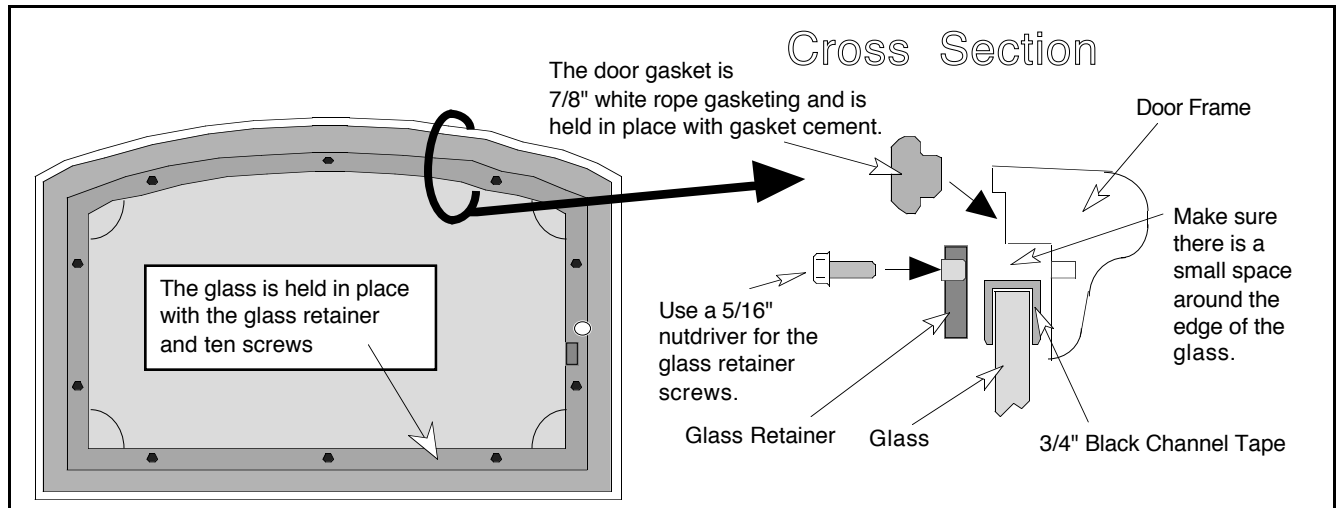

Replacing the Glass or Glass Gasket

Remove the glass retainer by unscrewing the ten screws that hold it in place with a 5/16" nutdriver (see the illustration above). Carefully remove the glass. Make sure the 7/8" black tape gasket (new or old) runs along the perimeter of the glass. If using a new gasket, trim off any excess. Place the glass (new or old) in place so there is a small gap between the edge of the glass and the door frame. Make sure the gasket is tucked underneath the glass so the glass does not touch the door frame. Place the glass retainer in place and secure it with the screws removed earlier. Make sure the white gasket stays in place and seals the window. Tighten the glass retainer until the gaskets start to flatten.

| Problem: | Possible Cause: | Don't Call for Service Until You: |
|---|--|--|
| Pilot Will Not Light | A gas shut off valve is turned off The valve control knob isn't turned to "PILOT" The valve control knob isn't pushed in The igniter wasn't pressed repeatedly | Check all gas shut off valves See "Starting the Pilot Light" Step C See "Starting the Pilot Light" Step C See "Starting the Pilot Light" Step C |
| Main Burners Will Not Start | The pilot light has gone out The ON/OFF switch is turned to "OFF" The remote control is not working correctly The thermostat is disconnected or set too high | See "Starting the Pilot Light" Turn the ON/OFF switch to "ON" See "Remote Control Operation" See "Thermostat Operation" |
| Remote Control Does Not Work | The pilot light has gone out The ON/OFF switch is turned to "OFF" The remote is too far away from the heater The remote control receiver is turned "Off" or "On" One of the two remote control batteries is dead | See "Starting the Pilot Light" Turn the ON/OFF switch to "ON" Use the remote closer to the heater See "Remote Control Operation" See "Remote Control Operation" |
| Thermostat Does Not Work | The pilot light has gone out The ON/OFF switch is turned to "OFF" The thermostat is set too high | See "Starting the Pilot Light" Turn the ON/OFF switch to "ON" See "Thermostat Operation" |
| Heater Will Not Distribute Heat | The heater is unplugged The heater is not up to temperature | Plug the heater in. See "Operating Your Heater" |
| Pilot Goes Out Once A Month Or More | The gas supply has not been shut off The vent is experiencing a cold air blockage or a negative pressure situation exists in the home | Keep the gas supply turned on This is a necessary safety feature that disables the heater if a down draft occurs. If this problem is persistent the vent may need to be improved or changes may need to be done to remove the negative pressure inside the home - see your dealer for details |
| Flame (and Pilot) Goes Out 10 to 25 Minutes After Starting | The vent is experiencing a cold air blockage or a negative pressure situation exists in the home | This is a necessary safety feature. First try restarting the heater. If it works correctly, a cold air blockage occurred and the vent just needed to be heated sufficiently. If this problem is persistent the vent may need to be improved or changes may need to be done to remove the negative pressure inside the home - see your dealer for details |
| Flames Are Too Blue | The heater has just been started | This is normal - see "Operating Your Heater" |
| Flames Are Orange With Dirty Smoke | Something may be placed against the heater | See "How this Heater Works" |
| Flames Are Too Short (Under 6") | The flame height may be turned too low Something may be placed against the heater | Turn the flame height to "HI" - See "Operating Your Heater" See "How this Heater Works" |
| Thin Layer of Soot Covers the Glass | The logs are placed incorrectly | See "Installing the Logs and Coals" |

How this Heater Works

This gas heater is designed with safety as the primary concern. Most of the components inside this heater are used for safety purposes. Therefore, only certified gas service technicians should service this heater. Your dealer can help you find a certified gas service technician.

What Turns the Main Burners On and Off

This heater uses a "millivolt system" to control its operation. A millivolt is a very small measurement of electricity. The thermopile, located directly next to the pilot light, generates electricity when it is heated by the pilot light. If the pilot is not lit, the thermopile does not generate electricity. This electricity is used to keep the gas valve open. Without it, the gas valve shuts off all gas to the heater. That is why when starting the pilot the gas control knob has to be pressed in long enough for the thermopile to heat up and start generating electricity. This current not only keeps the gas valve open but also provides electricity for the ON/OFF switch, remote control, or thermostat (see the illustration below). Because the thermopile generates the electricity needed to turn the heater on and off, this heater can be operated when the power is out (but the blower will not run).

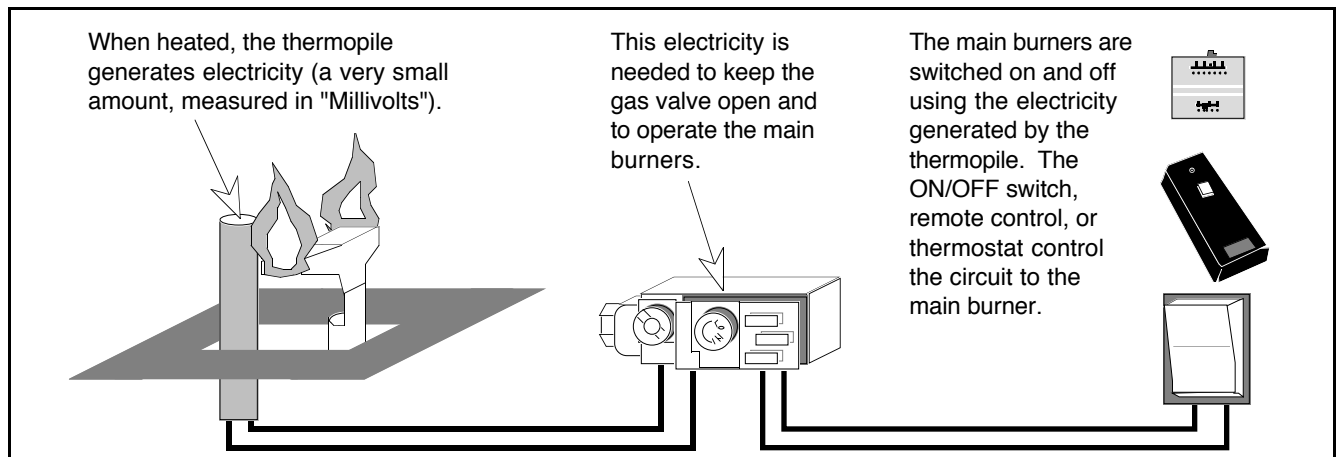

Why Nothing Should Be Placed Against the Heater

Your heater has a grill below the ashlip and convection air openings on the side and top that must not be blocked. The grill below the ashlip allows air into the firebox. If it is blocked the combustion inside the firebox will not burn normally. This will result in reduced efficiency and the exhaust gases will become dirty. The convection air openings on the side and top are used to draw room air over the hottest parts of the heater and distribute the warmed air into the room. If they are blocked, the heater will not heat as well and may become too hot internally.

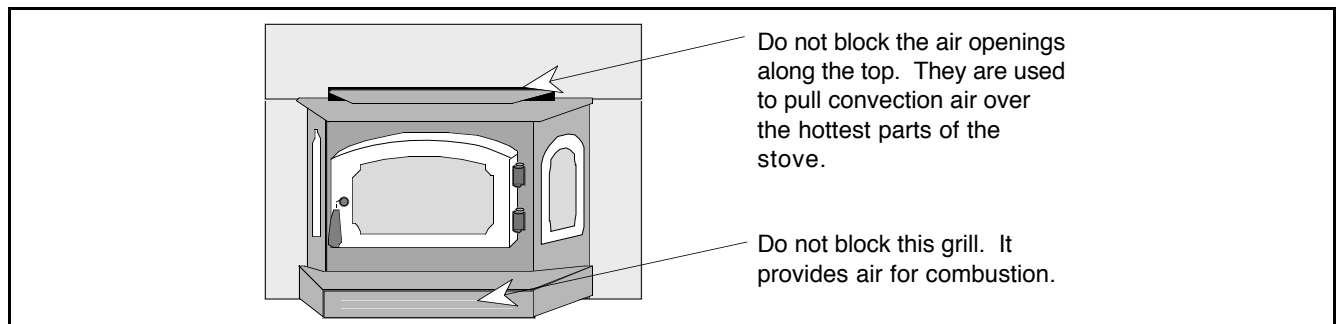

What Prevents Gas Buildup

Your heater has a high technology gas valve in combination with safety sensors which prevent any gas from building up. It also has a pilot light inside the firebox, which is a proven method for preventing gas buildup.

While the main burner is off

There is a thermopile directly next to the pilot light which can sense if the pilot is still lit. If the pilot goes out, this thermopile will no longer generate electricity which will cause the gas valve to automatically shut off all gas to the unit. This prevents the pilot light from spilling gas into the firebox.

While the main burner is on

The pilot light insures that the gas ignites inside the firebox, and that no gas builds up. In the unlikely case of the vent blocking, there is a sensor which will sense any backdrafts or over-heating. This sensor will signal the gas valve to shut off all gas to the unit if the vent is blocked.

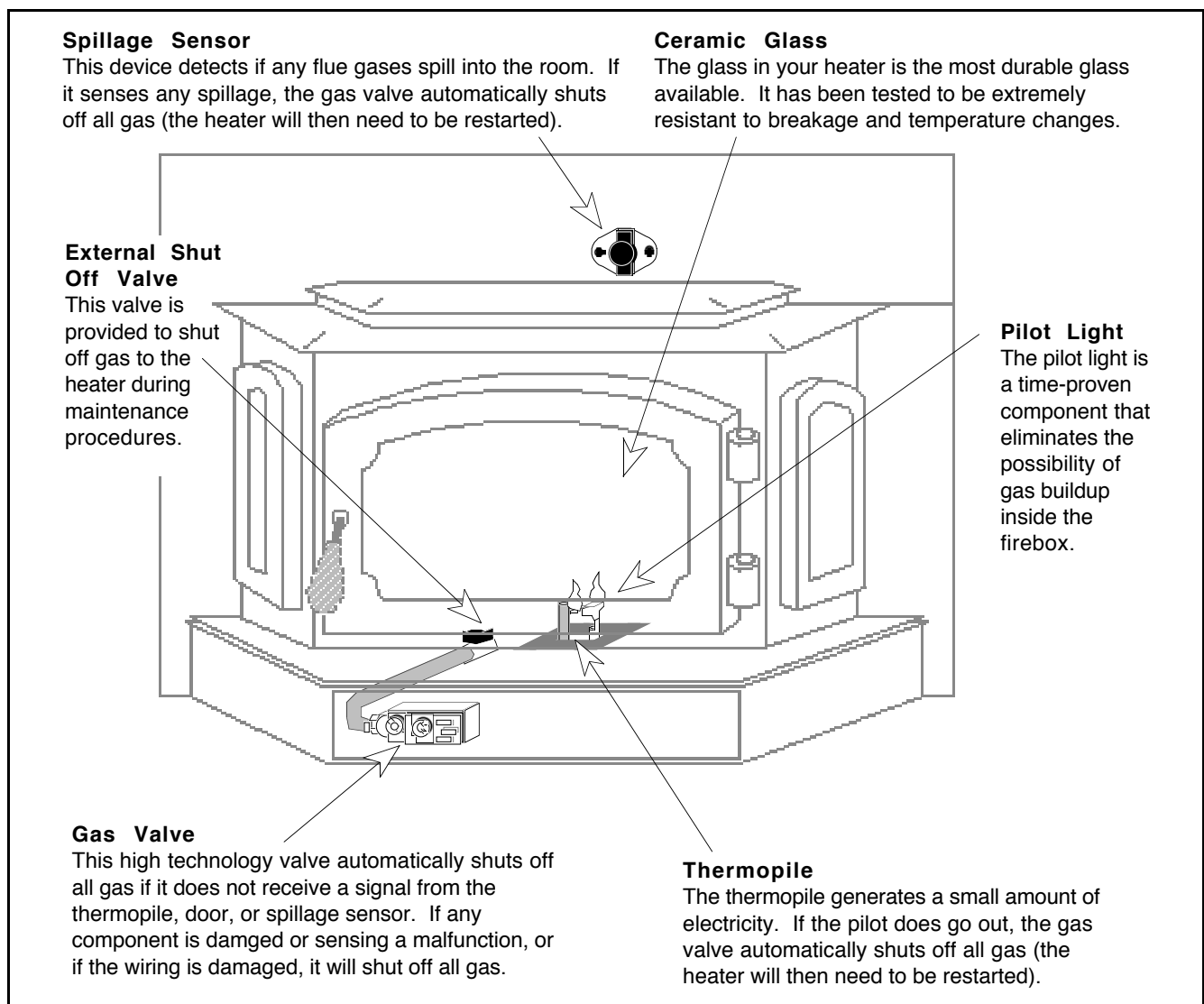

Wiring Diagram

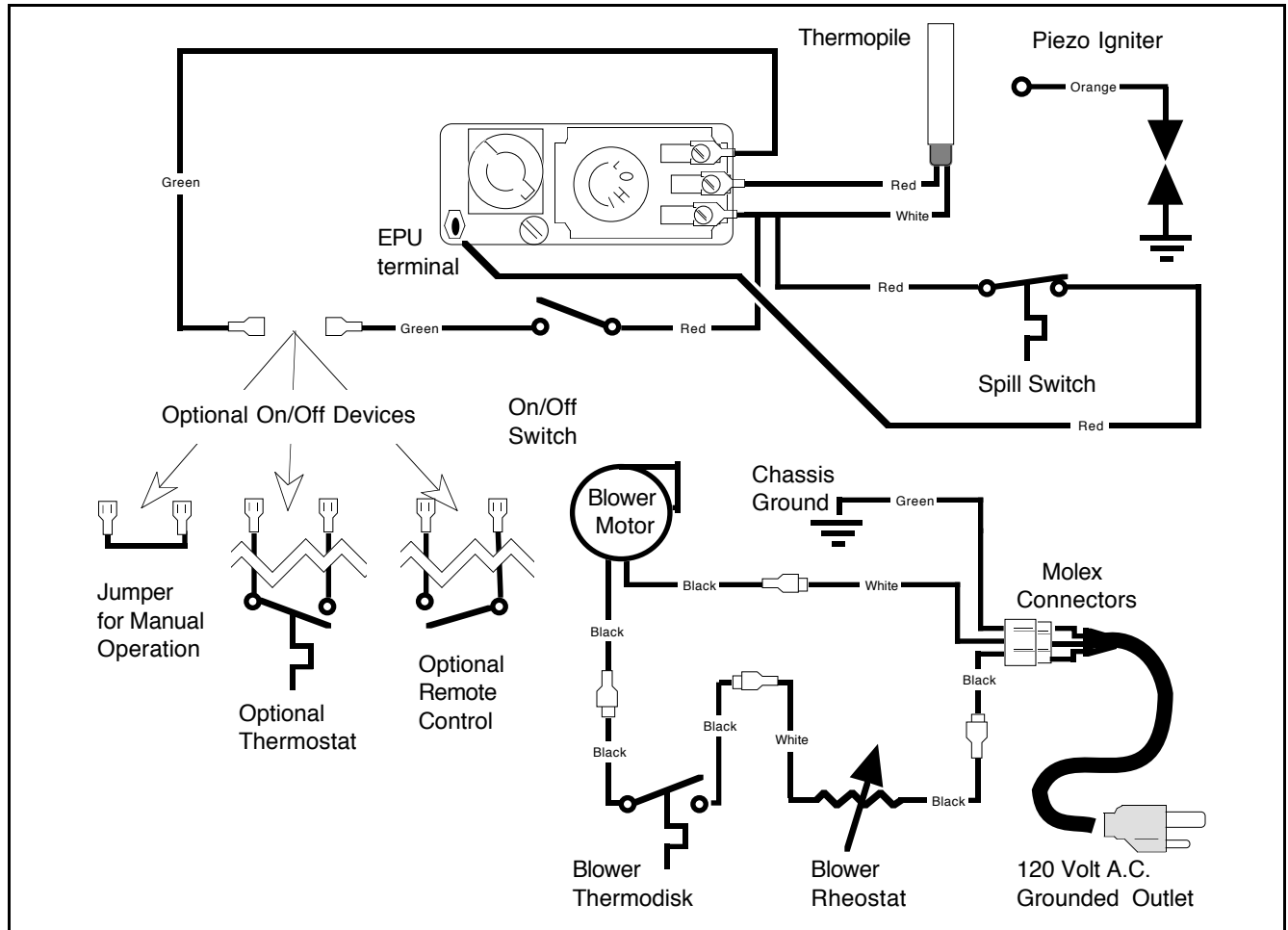

Replacement Parts List

Replacement parts are available at your dealer. Contact Travis Industries for information on the closest dealer. The parts listed below are the only parts that the consumer may replace. All other parts must be replaced by a qualified gas service person.

| PART | Part description |
|--------------------------|---|
| Door Gasket | Black 7/8" dia. Fiberglass rope 56" long |
| Glass Gasket | Black 3/8" dia. Fiberglass rope 62" long |
| Door Glass | 5 mm neoceram, 10 1/8" tall @ center, 17.094" wide |
| Glass Clips | Four clips used to hold glass in place, includes 4 self-adhesive fiberglass strips & 8 screws |
| Handle for Door | Wood handle |
| Door Handle | Steel shaft with threaded end (includes wood handle) |
| Log Set (includes coals) | Front and back log, left and right twig, and coals (ceramic fiber) |
| Owner's Manual | This document |

TRAVIS INDUSTRIES, INC. warrants the LOPI Spirit Bay gas heater to be defect-free in material and workmanship for five (5) years from the date of purchase, with the exception of the glass, paint, electrical components, switches, piezo igniter, fans, gaskets, logs, moving parts, gas valve, manifold, and burner pan. This does not include service call cost or any other additional charges. Check with your dealer for all costs if arranging a warranty call. The exceptions listed are warranted for one (1) year from the date of purchase to be defect-free in material and workmanship, with the exception of the glass and paint, which are not covered by the warranty.

Exclusions to this limited warranty include: Injury malfunction to the product, loss, damage, defect, failure to function due to accident, negligence, misuse, improper installation, alteration or adjustment of the manufacturers settings of components, lack of proper and regular maintenance, damage incurred while the unit is in transit, alteration, or act of God.

This limited warranty excludes damage caused by normal wear and tear, such as paint discoloration or chipping, worn or torn gasketing, logs, coals, etc. Also excluded is damage to the unit caused by abuse, improper installation, modification of the unit, drilling of the orifices, or the use of fuel not listed on the sticker on top of the gas control valve.

TRAVIS INDUSTRIES, INC. is free of liability for any damages caused by the unit, as well as inconvenience expenses, material and labor charges incurred by the removal or reinstallation of any LOPI Spirit Bay unit. Incidental or consequential damages are not covered by this warranty. In some states, the exclusion of incidental or consequential damage may not apply.

This warranty does not cover any loss or damage incurred by the use or removal of any component or apparatus to or from the LOPI Spirit Bay unit without the express written permission of TRAVIS INDUSTRIES, INC. and bearing a TRAVIS INDUSTRIES, INC. label of approval.

Any statement or representation of LOPI Spirit Bay products and their performance contained in LOPI Spirit Bay advertising, packaging literature, or printed material is not part of this limited warranty.

This warranty is automatically voided if the unit's serial number has been removed or altered in any way.

Only the original purchaser of a LOPI Spirit Bay heater is covered by this warranty. If the unit is used for commercial purposes, it is excluded from this warranty.

No dealer, distributor, or similar person has the authority to represent or warrant LOPI Spirit Bay products beyond the terms contained within this warranty. TRAVIS INDUSTRIES, INC. assumes no liability for such warranties or representations.

THIS LIMITED WARRANTY IS THE ONLY WARRANTY SUPPLIED BY TRAVIS INDUSTRIES, INC., THE MANUFACTURER OF THE UNITS. ALL OTHER WARRANTIES, WHETHER EXPRESS OR IMPLIED, ARE HEREBY EXPRESSLY DISCLAIMED AND PURCHASER'S RECOURSE IS EXPRESSLY LIMITED TO THE WARRANTIES SET FORTH HEREIN.

This warranty is limited to the time frame set forth above. In some states, time limitations on warranties do not apply.

HOW TO USE YOUR LOPI Spirit Bay FIVE-YEAR WARRANTY: If you find your unit to be defective in workmanship or material within a 5-year period from the date of purchase contact your local authorized LOPI Spirit Bay dealer. If your dealer is unable to repair your unit's defect, he may process a warranty claim through TRAVIS INDUSTRIES, INC., including the name of the dealership where you purchased the unit, a copy of your receipt showing the date of the unit's purchase, and the serial number on your unit. At that time, you will be asked to ship your unit, freight charges prepaid, to TRAVIS INDUSTRIES, INC. TRAVIS INDUSTRIES, INC., at its option, will repair or replace, free of charge, your LOPI Spirit Bay unit if it is found to be defective in material or workmanship within the time frame stated within this limited warranty. TRAVIS INDUSTRIES, INC. will ship your unit, freight charges prepaid by TRAVIS INDUSTRIES, INC., to your regional distributor, or dealership.

To register your TRAVIS INDUSTRIES, INC. Five-Year Warranty, complete the enclosed warranty card and mail it within ten (10) days of the unit purchase date to: TRAVIS INDUSTRIES, INC., 10850 117th Place N.E., Kirkland, Washington 98033.

OTHER RIGHTS:

This warranty provides you with certain legal rights. You may have additional rights, which vary from state to state, in regards to this warranty.

Unit Serial Number _____

Date of Purchase _____

Dealer Name and Address _____

Complete and
save for your
records

Travis Industries, Inc. reserves the right to change, without notice, product features or specifications described.





SPIRIT BAY (300 GR)

WH-

Listed Gas-Fired Vented Room Heater

Tested to ANSI Z21.11.1-1991 Gas-Fired Vented Room Heaters (Report # 6677 - Sept. 1993)
 Must be installed in accordance with all local codes, if any; if not, follow ANSI Z223.1
 and the requirements listed in the accompanying owner's manual.

This unit is equipped for use with NATURAL GAS ■ PROPANE(L.P.) ■

| Natural Gas Specifications: | LP. | N.G. |
|-------------------------------|--------|--------|
| Maximum Input Rating (BTU/Hr) | 31,000 | 31,000 |
| Minimum Input Rating (BTU/Hr) | 17,000 | 18,000 |
| Front Burner Orifice (DMS) | .0625" | #37 |

| Pressure Specifications: | LP. | N.G. |
|--|-------|------|
| Manifold Pressure HI Setting (in W.C.) | 11" | 3.5" |
| Manifold Pressure LO Setting (in W.C.) | 2.7" | 1.0" |
| Minimum Inlet Pressure (in W.C.) | 11.5" | 5.5" |

Minimum Clearance to Combustibles

| | |
|-----------------------------|-------|
| A. Unit to Sidewall | 10" |
| B. Side Facing | 8" |
| C. Top Facing | 8" |
| D. Unit to Mantle | 17.5" |
| E. Hearth Extension (Front) | 0" |
| F. Hearth Extension (Side) | 0" |

Blower Electrical Rating: 115 Volts, 1.5 Amps, 60 Hz.
 FAN TYPE VENTED CIRCULATOR

WARNING:

Operation of this heater when not connected to a properly installed and maintained venting system or tampering with the vent safety shutoff system can result in carbon monoxide (CO) poisoning and possible death.

Improper installation, adjustment, alteration, service or maintenance can cause injury or property damage. Refer to the information in the owner's manual provided with this appliance. For assistance or additional information consult a qualified installer, service agency or the gas supplier.

Risk of electrical shock. Disconnect power before servicing unit. Do not route power cord beneath heater.

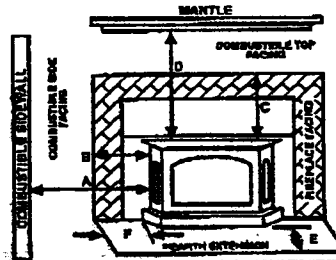

| | | | | |
|-------------|--------|--------|--------|--------|
| Manufacture | ■ 1994 | ■ Jan. | ■ May | ■ Sep. |
| Date: | ■ 1995 | ■ Feb. | ■ Jun. | ■ Oct. |
| | ■ 1996 | ■ Mar. | ■ Jul. | ■ Nov. |
| | ■ 1997 | ■ Apr. | ■ Aug. | ■ Dec. |

Travis Industries, Inc.
 10850 117th Pl. N.E. Kirkland, WA 98033

DO NOT REMOVE THIS LABEL MADE IN U.S.A.

Surround Panel Installation (See table below for part number)

Surround panel size is determined by the size of the fireplace opening. Panels that overlap the fireplace opening are usually more attractive. The table below details the size of the surround panels when installed. Questions should be directed towards your dealer.

| SURROUND PANEL SIZE | HEIGHT | WIDTH | PART # |
|---------------------|---------|---------|----------|
| 8" | 27 3/4" | 40 1/2" | 99300102 |
| 10" | 29 3/4" | 44 1/2" | 99300103 |
| 12" | 31 3/4" | 48 1/2" | 99300110 |

Place the insert 12" from the fireplace opening before installing the surround panels.

1. Follow the directions in the illustration below to install the side panels.

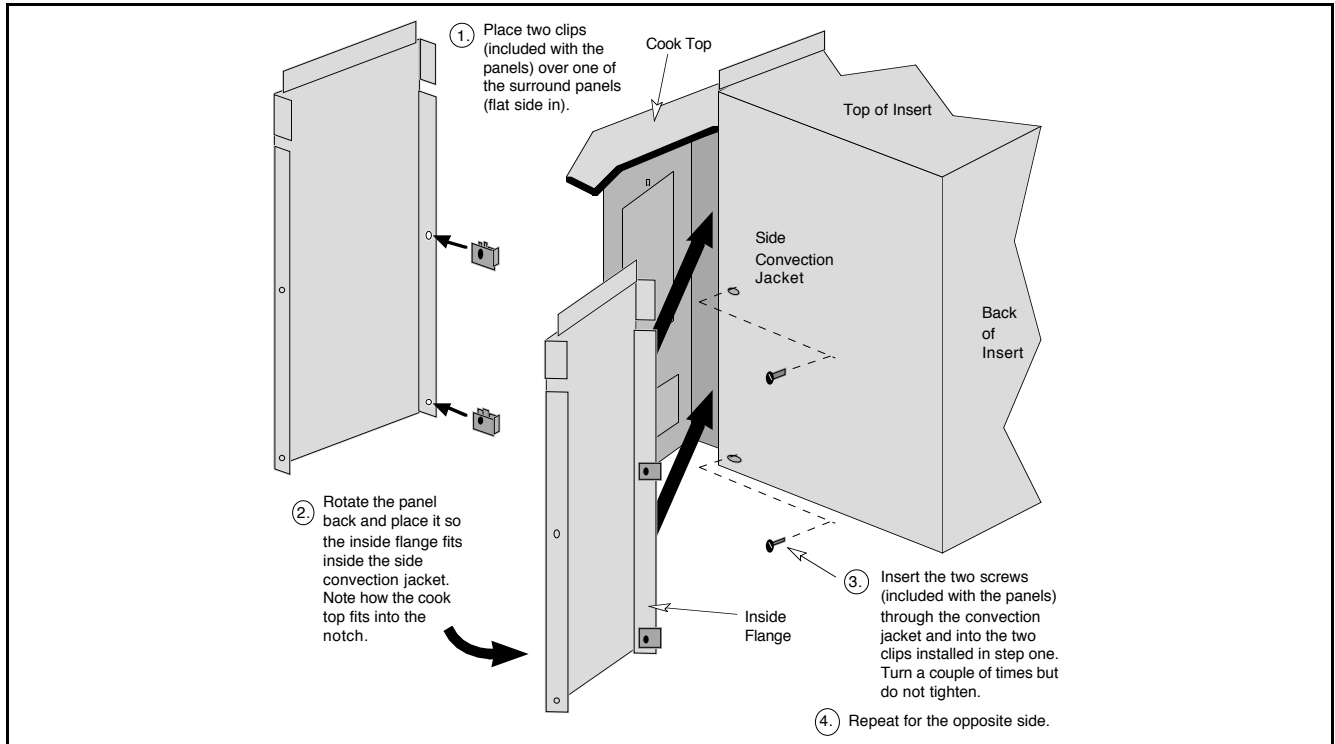

3. Install the top panel (see the illustration below). Adjust the top panel so its edges are flush with the side edges of the side panels.

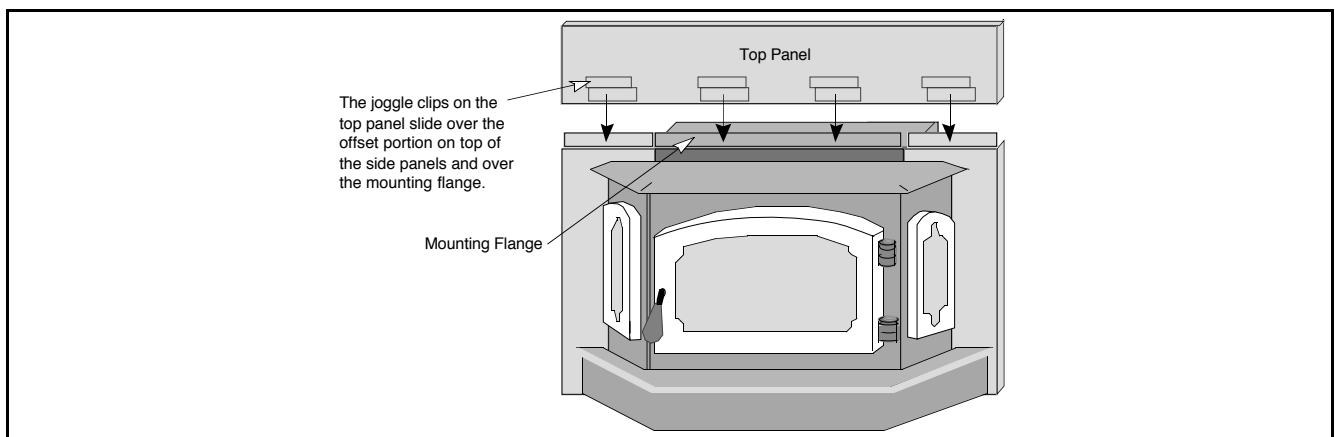

4. Adjust the position of the side panels so they are: 1) flush with the bottom of the insert; 2) both the same distance back from the front of the insert; 3) perpendicular to the floor. Tighten the nuts that hold the side panels in place.

NOTE: Discard the insulation that comes with the surround panels (for wood stoves only). The panels must not form an air-tight seal against the fireplace.

Brass Trim Installation (Optional)

The optional surround panel brass trim greatly enhances the appearance of your insert and is easy to install. Follow the directions below to install.

1. Lay the three pieces of brass trim on the floor in front of the insert. Arrange the brass trim so that it resembles the illustration below. The rounded edge of the trim that will be facing outwards when installed should be facing down.
2. Insert each "L" bracket leg into the groove in the 45° cut end of each side piece. Slide the other leg of each "L" bracket into the groove in each end of the top piece. Tighten the four set screws with a screwdriver into the "L" brackets, insuring that the 45° cuts are butted together to form a neat joint. Pick up the brass trim and slide it over the top panel until the trim is flush with the bottom edge of the top panel.

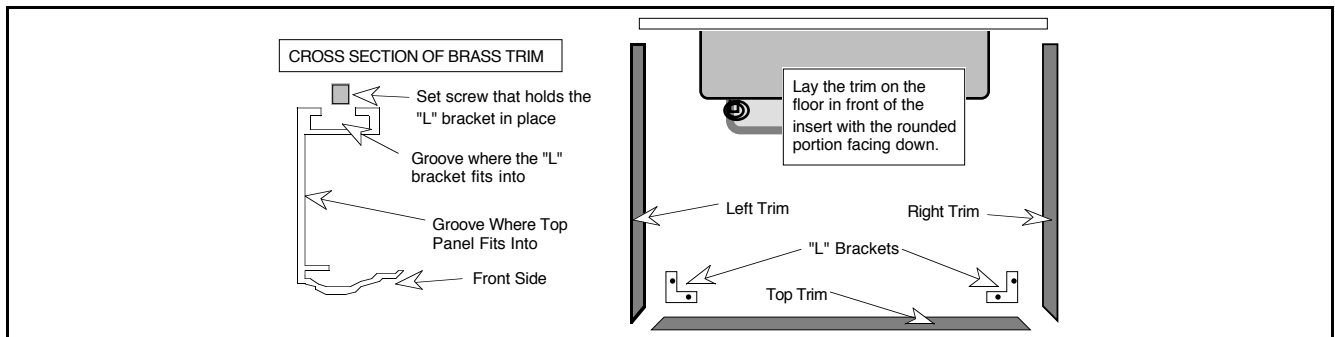

Telescoping Leg Installation (Part number 99200120)

The telescoping legs are designed to support the front end of fireplace inserts on raised hearths. It is adjustable from 4 5/8" to 7 1/2". It can be cut shorter by using a hacksaw (see the illustration below).

1. Place the end caps into each lower segment of the telescoping legs (see the illustration below).
2. Screw the telescoping legs together so the leg can be screwed into the bottom of the insert. Hand tighten the telescoping leg into position.
3. While grasping the upper segment of the telescoping leg, unscrew the bottom segment until it reaches the floor and supports the insert.

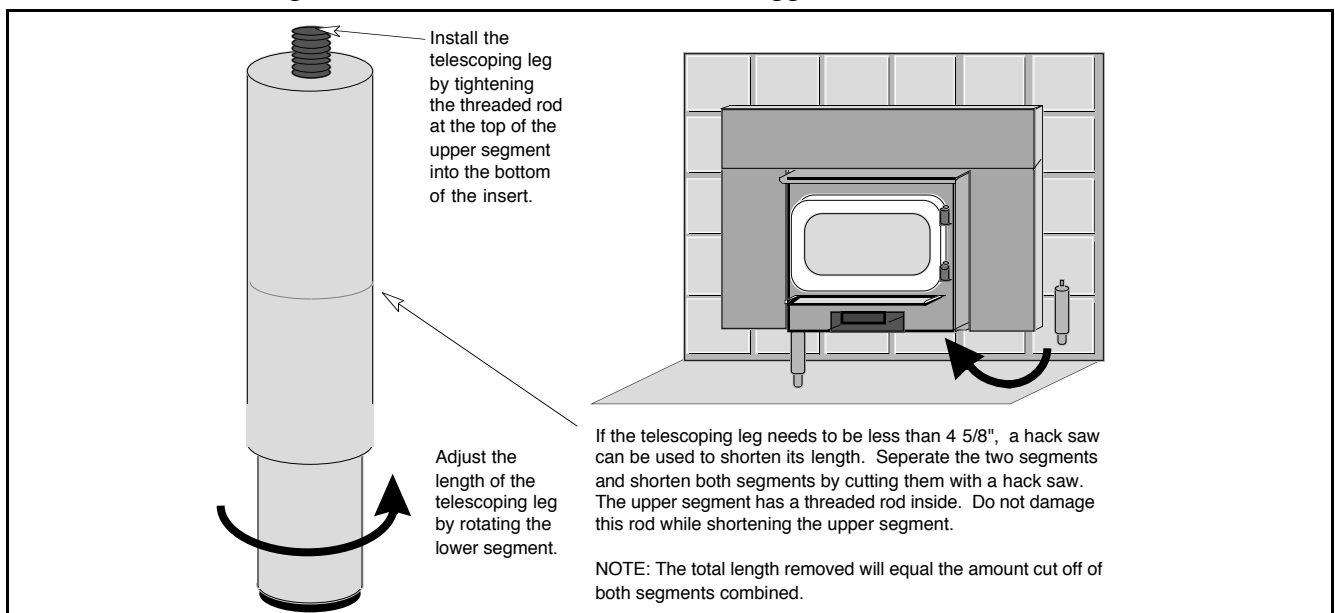

Remote Control (Part # 99300651)

The remote control allows remote operation of the main burner. Follow the directions below to install.

1. With the gas shut off and the heater unplugged, remove the ashlip control housing by unscrewing the three attachment screws with a 7/16" nutdriver. Carefully lay the ashlip control housing face down in front of the heater.

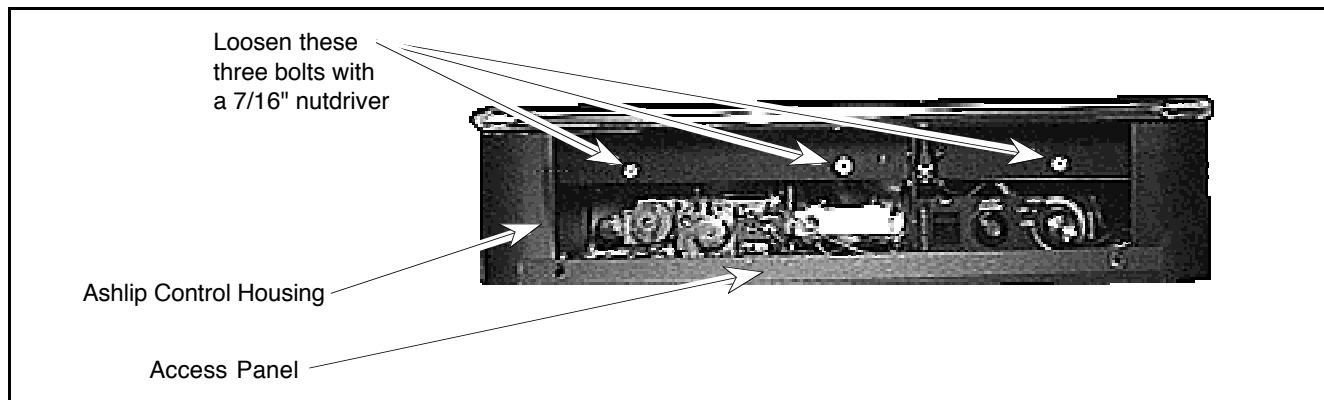

2. Locate the 2" long green jumper wire. It can be found near the on/off switch. Remove the jumper wire from the two green wires it attaches to (one leading to the on/off switch, the other to the gas control valve).
3. The remote control receiver wire enters the ashlip control housing in the same location the power cord does. Use a pair of slip joint pliers to remove the strain relief that holds the power cord in place (see the illustration below). Unwind the remote control receiver wire and route the end with quick connects through strain relief and to a location near the on/off switch. Insert the strain relief back in the hole until it snaps into place.

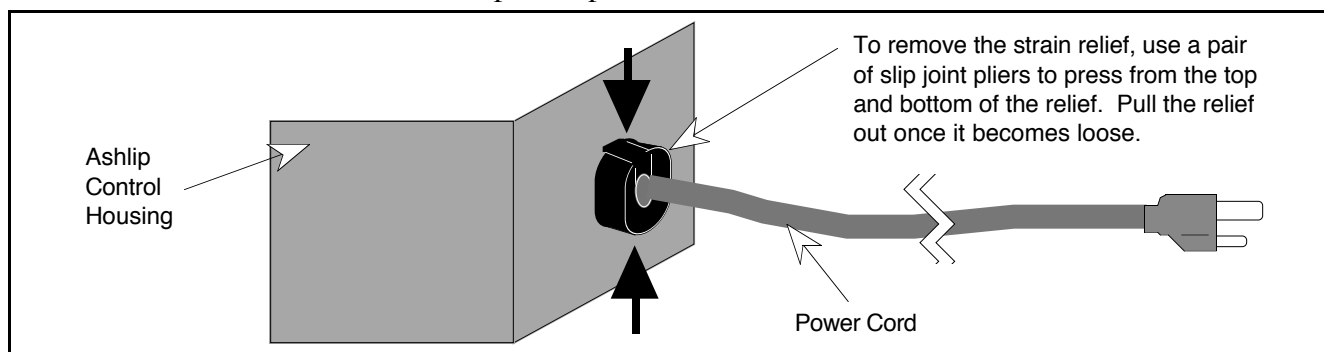

4. Attach the thermostat wire to the two green wires that were detached in step 2. Make sure to route the remote control receiver wire through the notch in the ashlip control housing partition if it entered through the center or left side (see the illustration below).

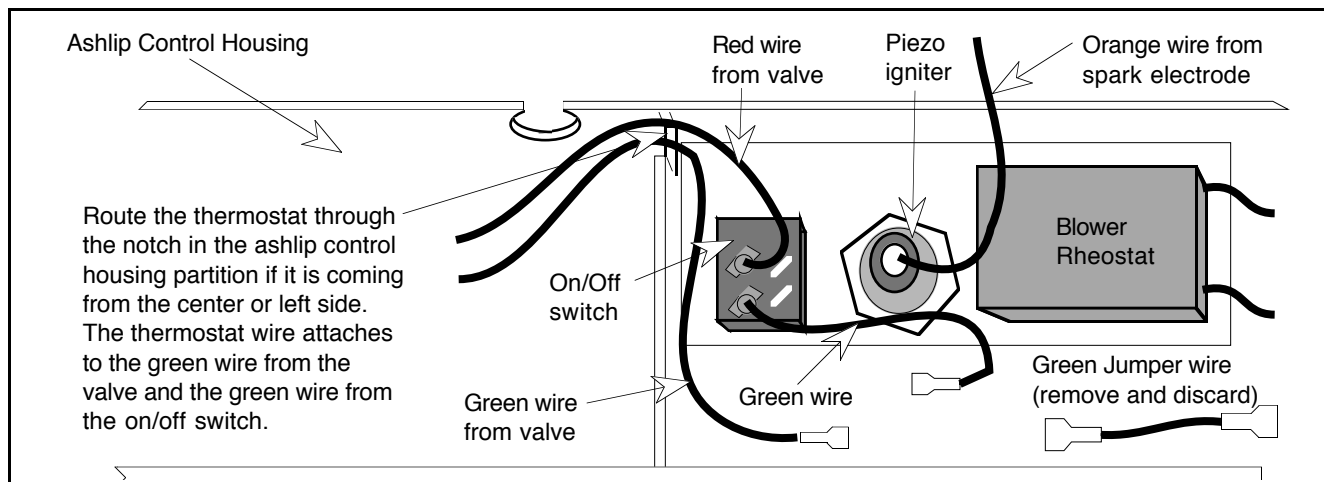

Remote Control (continued)

5. Replace the ashlip control housing. Make sure none of the wiring is pinched. Determine the location of the remote control receiver. Find a location that is within reach of 10' of wire. Route the remote control receiver wire to the location and connect it to the remote control receiver by attaching the quick connects (the orientation of the wires does not matter).
6. Place a nine volt battery inside the remote control receiver and remote control (see the illustration below).

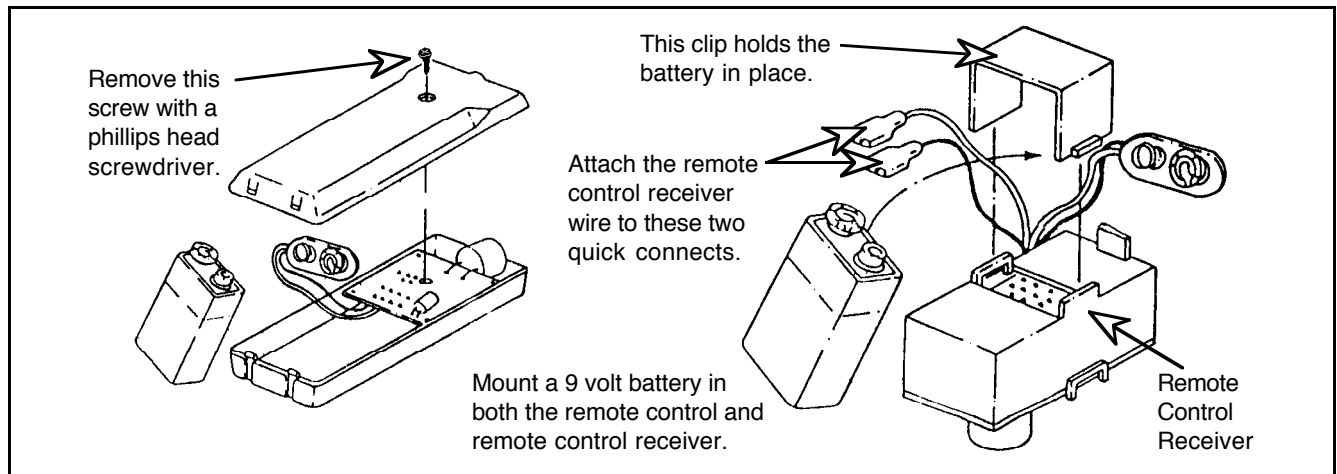

7. Mount the remote control receiver to the wall using two screws (not included). The screws pass through the cover plate and hold the remote control receiver in place.

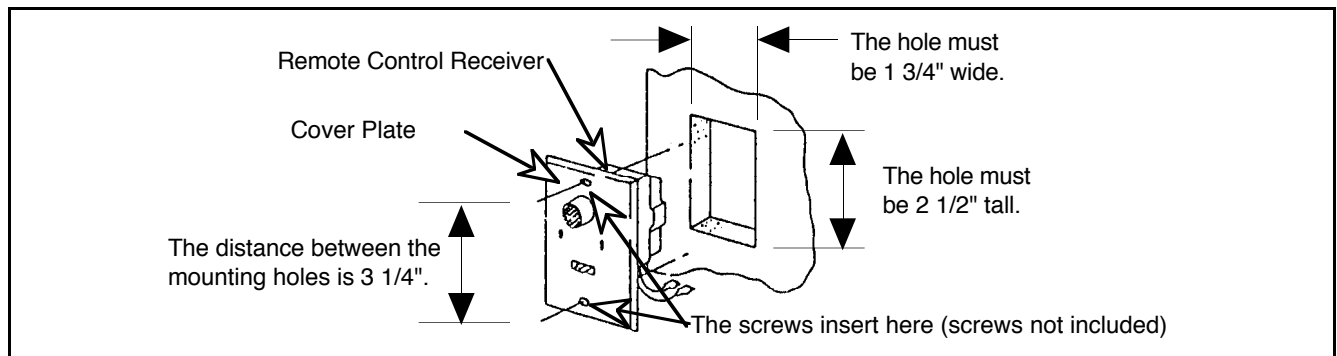

8. Test the remote control's operation prior to leaving the installation. Start the pilot, let it run five minutes, then turn the on/off switch on the heater to "ON". Switch the remote control receiver to "REMOTE". Press the remote control for one second to turn the heater on and off. If it does not, check all of the electrical connections and re-test. When the remote control receiver is turned to "ON" the heater will stay on, when on "OFF" the heater will stay off, regardless of the remote control.

Thermostat (Part # 99300650)

The thermostat allows the main burner to turn on and off automatically for consistent room temperature. Follow the directions below to install.

1. Follow step 1 and 2 under "Remote Control" to remove the ashlip control housing and jumper wire (see page 27).
2. Follow step 3 under "Remote Control" to feed the thermostat wire through the ashlip control housing (see page 27).

Thermostat (continued)

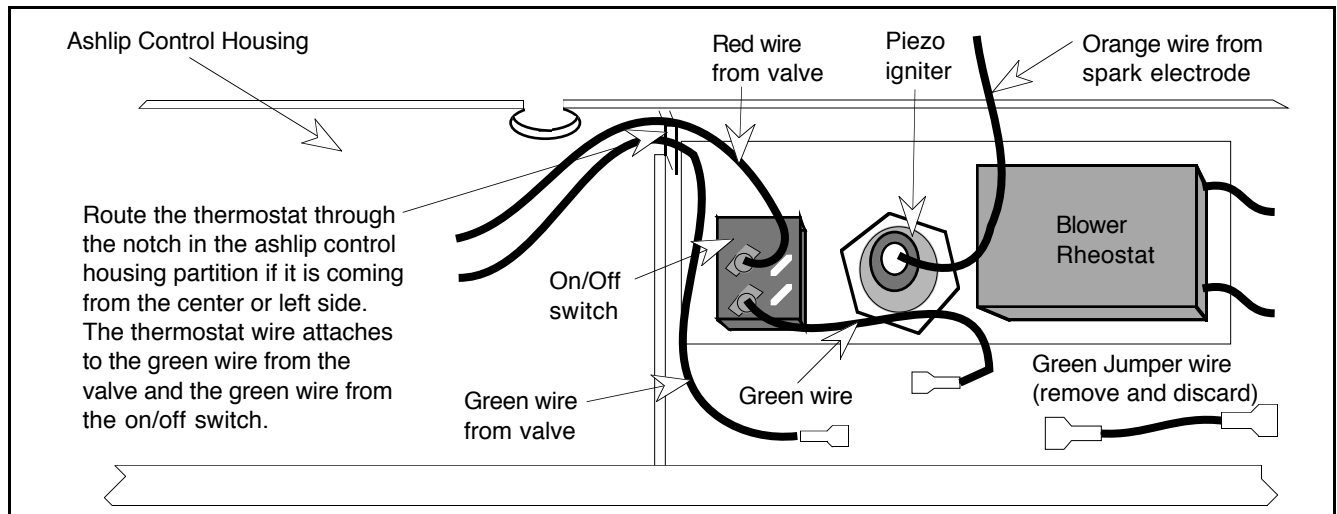

5. Replace the ashlip control housing. Make sure none of the wiring is pinched.
6. Determine the location of the thermostat. Find a location that is centralized in the room and within reach of 50' of wire. Route the thermostat wire to the location and attach the thermostat wire to the thermostat. Cut off any excess length of wire and expose approximately 1/2" of wire for connection to the thermostat. Attach the thermostat wire to the two clips on the thermostat using a standard screwdriver. Make sure the wire makes a good electrical contact.

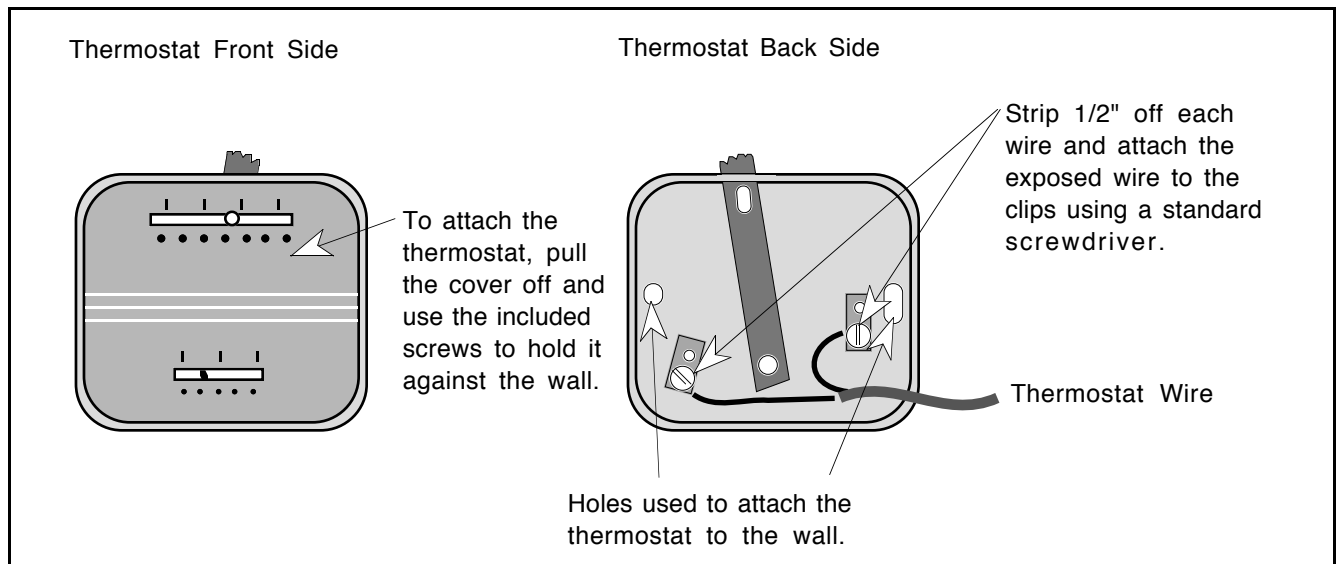

7. Remove the cover of the thermostat by pulling it apart carefully. The thermostat has mounting holes on each side of its base. Use the included screws to attach the thermostat to the wall. Tuck any excess wire behind the thermostat and replace the thermostat cover.
8. Test the thermostat's operation prior to leaving the installation. Turn the thermostat to it's highest position (all the way to the right). Start the pilot, let it run five minutes, then turn the on/off switch on. The heater should turn on. If it does not, check all of the electrical connections and re-test. The thermostat should turn the heater on when turned to its highest position, and turn off when turned to its lowest position. NOTE: if the temperature in the room is not between 50° and 90° this will not work because of the thermostat's range. Wait until a suitable temperature is achieved in the room before testing the thermostat.
6. Replace the ashlip control housing, making sure no wiring becomes pinched, and tighten the three bolts that hold it in place.

Re-Routing the Power Cord to the Left of the Heater

The power cord is normally routed to the right side of the heater. It may be re-routed to the left of the stove. The directions below detail this procedure.

1. TURN THE GAS LINE VALVE TO OFF AND UNPLUG THE HEATER (if the heater is connected or plugged in).
2. Use slip joint pliers to remove the strain relief that holds the power cord in place (see the illustration below).

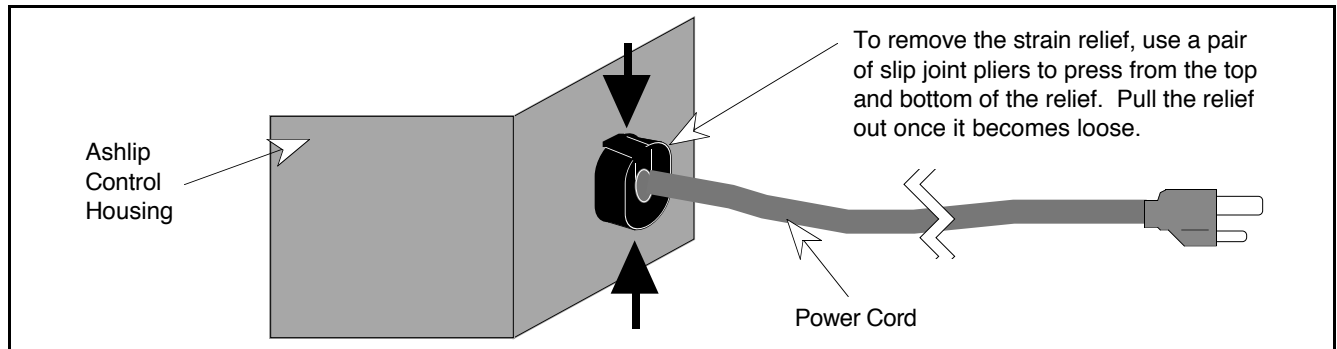

3. Open the access panel and with a 7/16" nutdriver loosen the three bolts that hold the control housing in place. When the control housing becomes loose, lift it off the bolts and place it face down in front of the heater. The wires that lead to the control housing can then be accessed.

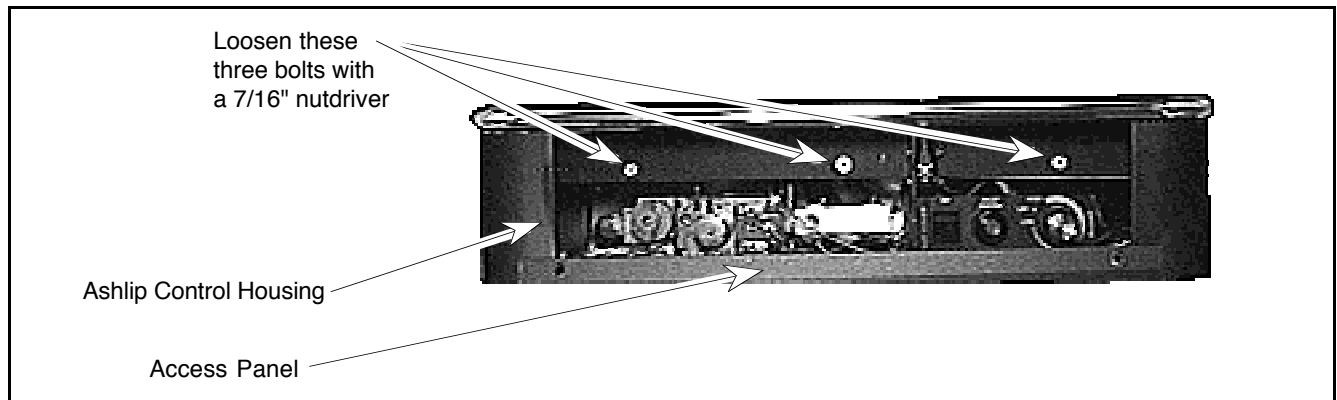

4. Disconnect the molex connector that attaches to the power cord. Remove the power cord from the heater by threading the molex plug through the hole in the ashlip control housing (see the illustration below).

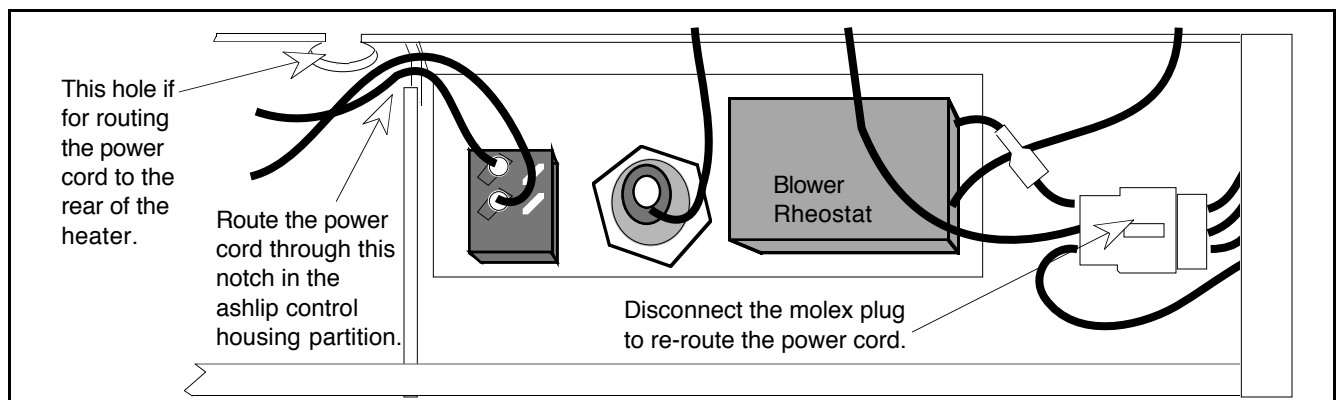

Re-Routing the Power Cord to the Left of the Heater (Continued)

5. Pry the button plug from the left side of the ashlip control housing using a screwdriver (see the illustration below). Insert it in the hole on the right side where the strain relief was removed. Insert the power cord through the hole on the left side. Route the power cord through the notch in the ashlip control housing partition and re-connect the power cord by connecting the molex plugs (see the illustration on the previous page). Place the strain relief over the power cord next to the ashlip control housing. Compress the strain relief by clamping it with a pair of slip nose pliers. Then insert it into the ashlip control housing until it locks into place.

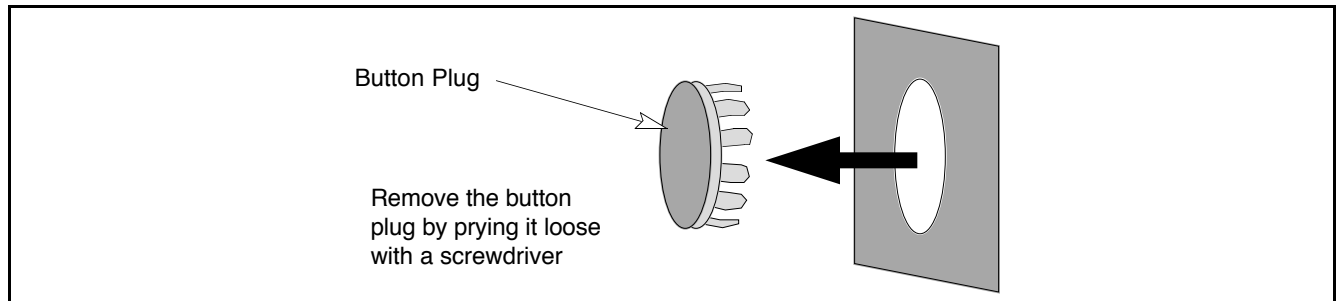

| | | | |
|---|--------------------|---|----|
| B vent | 7 | Paint Curing..... | 13 |
| Blower Speed..... | 15 | Panels (Surround Panels) | 25 |
| BTU Input..... | 5 | Parts List | 22 |
| Cap (vent termination) | 8 | Pilot (starting) | 12 |
| Clearances | 6 | Power Cord (re-routing to the left)..... | 30 |
| Controls..... | 11 | Propane Line Install (gas line install)..... | 8 |
| Dimensions..... | 5 | Propane Verses Natural Gas Heater..... | 2 |
| Door (inspection, removal, replacing components)..... | 18 | Purging Gas Line | 9 |
| Door Gasket..... | 18 | Remote Control (installation)..... | 27 |
| Emissions..... | 5 | Remote Control (operation)..... | 14 |
| Fan Speed | 15 | Replacement Parts..... | 22 |
| Firebox (inspection) | 16 | Reviewing the Installation | 10 |
| Flame Height..... | 15 | Running Your Heater..... | 13 |
| Flexible Tube Note | 8 | Safety Label | 24 |
| Floor Protection | 7 | Safety Precautions | 2 |
| Fuel..... | 5 | Sounds (normal operating sounds) | 15 |
| Gas Inlet Location | 8 | Starting The Pilot..... | 12 |
| Gas Leak..... See Inst. on Cover | | Starting the Heater for the First Time..... | 13 |
| Gas Line Install | 8 | Surround Panels (installation & size) | 25 |
| Gas Pressure | 9 | Table of Contents..... | 4 |
| Gas Smell..... See Inst. on Cover | | Telescoping Legs (installation)..... | 26 |
| Glass, Glass Gasket | 18 | Thermostat (installation)..... | 28 |
| Heater Placement | 6 | Thermostat (operation)..... | 14 |
| Heating Specifications | 5 | Troubleshooting Table..... | 19 |
| How this Heater Works..... | 20 | Turning the Heater On and Off..... | 14 |
| Leaking Gas | See Inst. on Cover | Vent Requirements | 7 |
| Listing Information..... | 24 | Vent termination | 8 |
| Logs and Coals (installation, removal) | 17 | Warranty..... | 23 |
| Manifold Pressure | 9 | Weight | 5 |
| Natural Gas Verses Propane Heater | 2 | What Prevents Gas Buildup | 21 |
| On/Off Operation..... | 14 | What Turns the Main Burners On and Off..... | 20 |
| Operating Sounds | 15 | Why Nothing Should Be Placed Against the Heater ... | 20 |
| Operating the Heater | 13 | Wiring Diagram..... | 22 |