

TRAVIS INDUSTRIES WOOD PRODUCTS



Wood Line-Up by Brand

Wood As Fuel

Emissions

Wood Venting

Wood Stove Placement

Wood Accessories

Wood Maintenance

TRAVIS INDUSTRIES WOOD PRODUCTS



AVALON

- Spokane 1250
- Spokane 1750
- Pendleton Wood Stove
- Rainier Wood Stove
- Olympic Wood Stove
- Arbor Cast Wood Stove
- Pendleton Wood Insert
- Perfect Fit Wood Insert
- Rainier Wood Insert
- Olympic Wood Insert

Lopi

- Republic 1250
- Republic 1750
- Answer Wood Stove
- Liberty Wood Stove
- Leyden Cast Wood Stove
- Answer Wood Insert
- Endeavor Wood Stove
- Revere Wood Insert
- Declaration Wood Insert
- Freedom Wood Insert
- Freedom Bay Wood Insert

FPX

- 33 Elite Wood Insert
- 36 Elite Wood Fireplace
- 44 Elite Wood Fireplace

TRAVIS INDUSTRIES WOOD PRODUCTS



Avalon Wood Burning Stoves SPOKANE

Model 1250

Height - Legs 26 1/2 Height - Pedestal 29 3/4
Width - 23 5/8 Depth - 14 5/8
Flue Center From Back - 4 1/8

Model 1750

Height - Legs 26 1/2 Height - Pedestal 30 5/8
Width - 24 Depth - 23 1/2
Flue Center From Back - 5 3/4

EPA Emissions 4.4 Grams/Hr.	Efficiency Up To 79.6 %	Maximum Btu s/Hour** 66,800	Firebox Size 1.6 Cu. Ft.
Heating Capacity* 600 to 1,200 Sq. Ft.	Maximum Burn Time** Up to 8 Hours	Maximum Log Length Up to 18 inches	Weight 243 Lbs.

EPA Emissions 1.9 Grams/Hr.	Efficiency Up To 79.6 %	Maximum Btu s/Hour** 72,400	Firebox Size 2.2 Cu. Ft.
Heating Capacity* 1,200 to 2,000 Sq. Ft.	Maximum Burn Time** Up to 10 Hours	Maximum Log Length Up to 18 inches	Weight 430 Lbs.

* Heating Capacity may vary depending on the degree of home insulation, floor plan, ambient temperature zone of the area in which you live.

** BTU Output and Burn Times may vary depending on moisture content of wood, wood type, chimney draft and oxygen supply.

Clearances To Combustibles

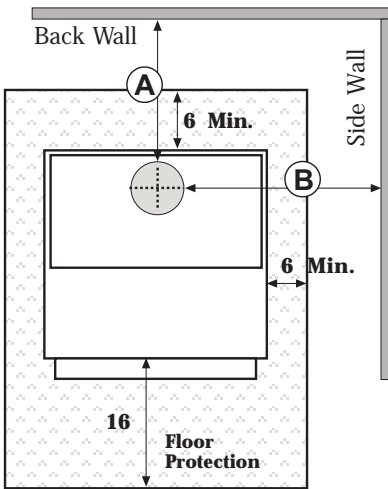

Model 1250	Single Wall Connector	Double Wall Connector
A =	19 1/4	11 1/4
B =	27	26 1/2
C =	17 3/4	17 1/4
D =	10	10

Model 1750	Single Wall Connector	Double Wall Connector
A =	15	4 1/4
B =	15	13
C =	24	15
D =	15	6 1/2

Measure rear and side clearances (A) (B) & (C) from edge of the stove flue. Measure corner clearance (D) from the top corner of stove.

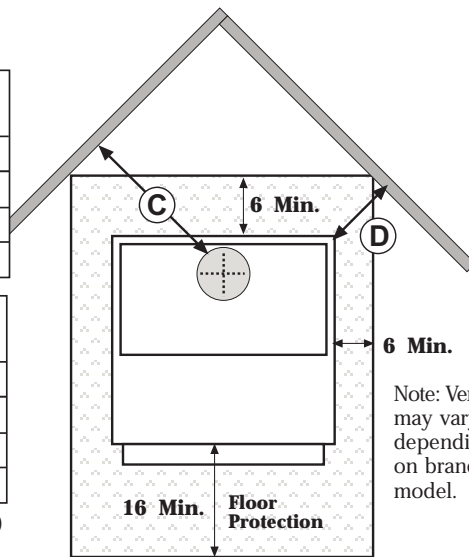

Note: Vent diameter may vary depending on brand and model.

Measure front, rear and side Hearth Pad clearances from edges of the stove top. Floor protection must be non-combustible and at least .018 thick (26 gauge). Minimum Hearth Pad Sizes: **Model 1250** - 36 Wide x 37 Depth **Model 1750** - 36 Wide x 45 1/2 Depth
For all installation and clearance information please consult the Owner s Manual or visit www.avalonfirestyles.com.

Avalon Wood Burning Stoves ARBOR

EPA Emissions	Overall Efficiency	Maximum Btu s/Hour**	Firebox Size	Heating Capacity*	Maximum Burn Time**	Maximum Log Length	Wood Capacity	Weight
2.4 Grams/Hr.	70 %	73,100	2.3 Cu. Ft.	Up to 2,000 Sq. Ft.	Up to 12 to 18 Hours	Up to 21 inches	45-65 Pounds	375 Lbs.

* Heating Capacity may vary depending on the degree of home insulation, floor plan, ambient temperature zone of the area in which you live.

** BTU Output and Burn Times may vary depending on moisture content of wood, wood type, chimney draft and oxygen supply.

DIMENSIONS

- 27 1/4 WIDE
- 22 7/8 DEEP
- 27 3/4 HEIGHT
- 25 1/4 HEIGHT TO FLUE CENTER (REAR VENT)
- 2 5/8 DEPTH TO FLUE CENTER FROM BACK (TOP VENT)

ALCOVE CLEARANCES

- Maximum Depth 48 Measured From Combustible Surfaces
- Maximum Width 63 1/4
- Minimum Height 84

CLOSE CLEARANCES TO COMBUSTIBLES

(Rear heat shield is a standard feature)

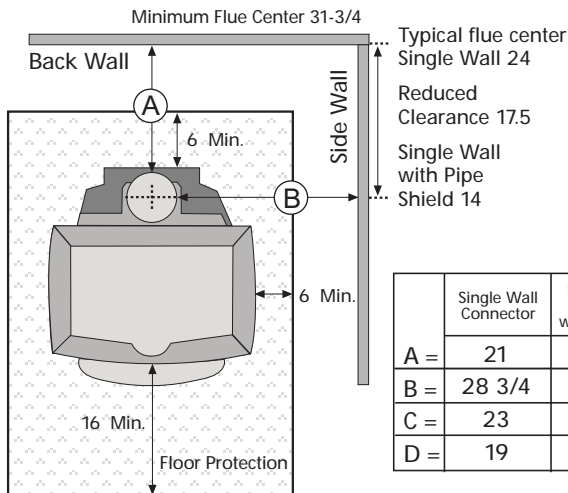

Measure front clearances from the face of the stove (door opening).

Measure rear and side clearances from the nearest edge of the stove top.

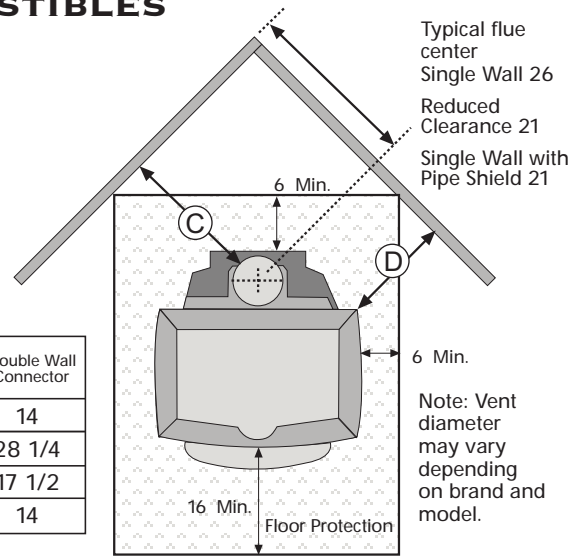

Measure rear and side clearances from the nearest edge of the stove top.

Measure front clearances from the face of the stove (door opening).

TRAVIS INDUSTRIES WOOD PRODUCTS



Avalon Wood Burning Inserts

	PENDLETON		RAINIER		PERFECT-FIT	OLYMPIC
	For smaller homes and for zonal heating needs. 45° Flue or 90° Flue Models		For mid-sized homes and for zonal heating needs. 45° Flue or 90° Flue Models		Flush wood insert for mid-sized homes and for zonal heating.	For larger homes and those who need a primary heat source.
Heating Capacity*:	600 to 1,200 SQ. FT.		800 to 1,800 SQ. FT.		1,200 to 2,000 SQ. FT.	1,500 to 2,500 SQ. FT.
Heat Output:	64,200 BTU's/HR		71,800 BTU's/HR		73,300 BTU's/HR	74,300 BTU's/HR
Overall Efficiency*:	68%		71.7%		71.7%	70%
Max. Burn Time:	Up to 8 Hours		Up to 9 Hours		Up to 12 Hours	Up to 12 Hours
Max. Log Size:	Up to 17"		Up to 20"		Up to 24"	Up to 24"
Fuel Capacity:	16 Lbs. of Wood		22 Lbs. of Wood		22 Lbs. of Wood	24 Lbs. of Wood
Weight:	285 Lbs.		345 Lbs.		450 Lbs.	465 Lbs.
Firebox Size:	1.3 Cu. In.		1.8 Cu. In.		2.9 Cu. In.	3.1 Cu. In.
Flue Diameter:	6"		6"		6"	6"
	45° Flue	90° Flue	45° Flue	90° Flue	90° Flue	90° Flue
Height:	20"	20 3/4"	21 1/8"	21 7/8"	21 1/2"	22 1/8"
Width in Front:	23 3/4"	23 3/4"	25 3/4"	25 3/4"	28 7/8"	29 3/8"
Width in Back:	23 3/4"	23 3/4"	25 3/4"	25 3/4"	21 1/4"	29 3/8"
Overall Depth:	16 1/8"	16 3/8"	19 3/8"	19 3/8"	21 3/4"	20 1/2"
Depth on Hearth:	4 3/4"	4 7/8"	10"	5 1/8"	1 1/4"	6 3/8" FL 8 7/8" EXT
Depth Into Fireplace:	11 3/8"	11 5/8" Masonry 12 5/8" ZC	9 1/2" Masonry 10 1/2" ZC	14 1/2" Masonry 15 1/2" ZC	20 1/2"	14 1/8" FL 11 5/8" EXT

* Wood appliance performance can be affected by negative pressure in the home and by prevailing atmospheric conditions. Contact local building or fire officials about restrictions and installation requirements in your area.

SURROUND FACING Select the panels to enclose your fireplace opening. Measurements indicate maximum coverage area.

OUTSIDE FIT PANELS - Designed to fit over the existing fireplace opening. Comes standard with black trim.

8" x 8" Panels:	39 3/4" W x 28" H	41 3/4" W x 28 7/8" H	45 1/2" W x 29 1/2" H	45 1/4" W x 28 7/8" H
10" x 10" Panels:	43 3/4" W x 30" H	45 3/4" W x 30 7/8" H	49 1/2" W x 31 1/2" H	49 1/4" W x 30 7/8" H
12" x 12" Panels:	47 3/4" W x 32" H	49 3/4" W x 32 7/8" H	53 1/2" W x 33 1/2" H	53 1/4" W x 32 7/8" H

INSIDE FIT PANELS - All Avalon panels sets can be cut down for a custom fit to the inside edges of your existing fireplace opening. It is the least obtrusive panel system and showcases your Avalon insert.

CLEARANCES TO COMBUSTIBLES complete installation information is available at your local Avalon dealer or on our website at www.avalonstyle.com.

	Masonry Fireplace	Metal (ZC) Fireplace	Masonry Fireplace	Metal (ZC) Fireplace	Masonry Fireplace	Metal (ZC) Fireplace	Masonry Fireplace	Metal (ZC) Fireplace	Metal (ZC) Fireplace	Metal (ZC) Fireplace
A = To Mantle	22"	24"	22"	24"	31 1/2"	24"	31 1/2"	24"	41 1/2" (Measured From Floor)	Flush 32" Extended 33"
A = To Mantle w/Shield*	16 1/2"	N/A	16 1/2"	N/A	16 1/2"	N/A	16 1/2"	N/A	N/A	19" 20"
B = To Top Facing	20"	12"	20"	12"	29 1/2"	12"	29 1/2"	12"	39" (Measured From Floor)	30" 31"
B = To Top Facing w/Shield*	14 1/2"	N/A	14 1/2"	N/A	14 1/2"	N/A	14 1/2"	N/A	N/A	17" 18"
C = To Sidewall	10"	30"	10"	30"	14"	30"	14"	30"	9"	15" 15"
D = To Side Facing	9"	12"	9"	12"	13"	12"	13"	12"	9"	13 1/2" 13 1/2"
E = Hearth Depth	20 3/4"	20 3/4"	20 3/4"	20 3/4"	26"	26"	21 1/8"	21 1/8"	17 1/4"	22 3/8" 24 7/8"
F = Hearth Sides	8"	8"	8"	8"	8"	8"	8"	8"	8"	8" 8"

* Mantle and Top Facing clearances can be reduced with the optional Mantle Shield

SIZING YOUR EXISTING FIREPLACE Minimum fireplace measurements required for installation

Minimum Requirements:	45° Flue	90° Flue	45° Flue	90° Flue	90° Flue	Flush	Extended
G = Height	20 1/2"	21 1/4"	21 1/2"	22 1/4"	21 1/2"	22 1/4"	22 1/4"
H = Front Width	24"	24"	26"	26"	30 7/8"	29 1/2"	29 1/2"
I = Back Width	24"	24"	26"	26"	21 1/4"	29 1/2"	29 1/2"
J = Depth	11 3/8"	11 5/8" Masonry 12 5/8" ZC	9 1/2" Masonry 10 1/2" ZC	14 1/2" Masonry 15 1/2" ZC	20 1/2"	14 1/8"	11 5/8"
K = Min. Lintel Depth	6 1/2"	4 1/2"	3 1/4"	7"	11"	5"	2 1/2"

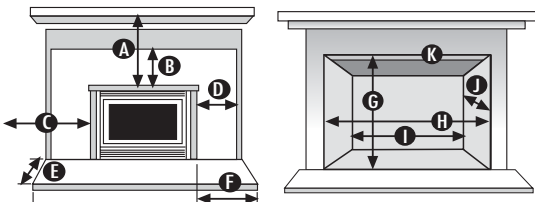

Write In Your Fireplace Dimensions:

G = Height
H = Front Width
I = Back Width

APPROVED ZERO CLEARANCE (METAL) FIREPLACES

Both the Pendleton and Rainier Inserts are approved for installation in the following zero clearance fireplaces. See the Owner's Manual for details.

MARCO
MAJESTIC
TEMPCO

HEATILATOR PREWAY
SUPERIOR

TRAVIS INDUSTRIES WOOD PRODUCTS



Lopi Wood Burning Stoves

	REPUBLIC 1250	REPUBLIC 1750	ANSWER	ENDEAVOR	LIBERTY					
	SMALL	MEDIUM	SMALL	MEDIUM	LARGE					
SPECIFICATIONS										
WIDTH	23 5/8"	24"	23 5/8"	24"	30"					
HEIGHT (ALL LEGS)	26 3/4"	26 1/2"	27 7/8"	30 5/8"	32 1/4"					
HEIGHT (PEDESTAL)	29 3/4"	30 5/8"	31 7/8"	34 5/8"	36 1/4"					
DEPTH	14 5/8"	23 1/2"	16 1/4"	23 1/2"	21"					
FLUE SIZE	6"	6"	6"	6"	6"					
CONSTRUCTION (PLATE STEEL)	1/4" TO 3/16"	5/16" TO 3/16"	1/4" TO 3/16"	5/16" TO 3/16"	5/16" TO 3/16"					
WEIGHT (BODY W/LEGS)	243 LBS.	430 LBS.	300 LBS.	448 LBS.	490 LBS.					
PERFORMANCE										
EMISSIONS	4.4 GRAMS/HR.	1.9 GRAMS/HR.	4.4 GRAMS/HR.	1.9 GRAMS/HR.	2.6 GRAMS/HR.					
HEATING CAP. (SQ FT.)	600 TO 1,200	1,200 TO 2,000	750 TO 1,400	1,200 TO 2,000	1,500 TO 2,500					
HEAT OUTPUT	66,800 BTU'S/HR.	72,400 BTU'S/HR.	66,800 BTU'S/HR.	72,400 BTU'S/HR.	74,300 BTU'S/HR.					
EFFICIENCY (DEQ)	UP TO 79.6%	UP TO 78.8%	UP TO 79.6%	UP TO 78.8%	UP TO 76.9%					
MAXIMUM BURN TIME	UP TO 8 HOURS	UP TO 10 HOURS	UP TO 8 HOURS	UP TO 10 HOURS	UP TO 12 HOURS					
FIREBOX SIZE	1.6 CUBIC FT.	2.2 CUBIC FT.	1.6 CUBIC FT.	2.2 CUBIC FT.	3.1 CUBIC FT.					
MAXIMUM LOG SIZE	UP TO 18"	UP TO 18"	UP TO 18"	UP TO 18"	UP TO 24"					
CLEARANCES										
	SINGLE WALL CONNECTOR	DOUBLE WALL CONNECTOR	SINGLE WALL CONNECTOR	DOUBLE WALL CONNECTOR	SINGLE WALL CONNECTOR	DOUBLE WALL CONNECTOR	SINGLE WALL CONNECTOR	DOUBLE WALL CONNECTOR	SINGLE WALL CONNECTOR	DOUBLE WALL CONNECTOR
A= STOVE TO SIDE WALL	18"	18"	15"	13"	18"	13"	15"	13"	16"	16"
B= STOVE TO BACK WALL	18"	10 1/2"	15"	4 1/4"	16 1/2"	9"	15"	4 1/4"	15"	10"
C= STOVE TO CORNER WALL	10"	10"	15"	6 1/2"	10"	7 1/2"	15"	6 1/2"	9 1/2"	7 1/2"
D= CONNECTOR TO SIDE WALL	27"	26 1/2"	24"	21 1/2"	27"	21 1/2"	24"	21 1/2"	28"	27 1/2"
E= CONNECTOR TO BACK WALL	19 1/4"	11 1/4"	17 3/4"	6 1/2"	19 1/2"	11 1/2"	17 3/4"	6 1/2"	18 1/4"	12 3/4"
F= CONNECTOR TO CORNER WALL	17 3/4"	17 1/4"	24"	15"	19 1/2"	16 1/2"	24"	15"	21"	18 1/2"
HEARTH PROTECTION										
G= FRONT	16"		16"		16"		16"		16"	
H= SIDES	6"		6"		6"		6"		6"	
I= BACK	6"		6"		6"		6"		6"	
ALCOVE										
J= MAXIMUM WIDTH	59 5/8"		54"		49 5/8"		54"		62"	
K= MINIMUM DEPTH	48"		48"		48"		48"		48"	
L= MINIMUM HEIGHT	84"		84"		84"		84"		84"	

CLEARANCES TO UNPROTECTED COMBUSTIBLES

USE THESE ILLUSTRATIONS IN CONJUNCTION WITH
THE INFORMATION UNDER THE "CLEARANCE" &
"ALCOVE" HEADINGS ABOVE.

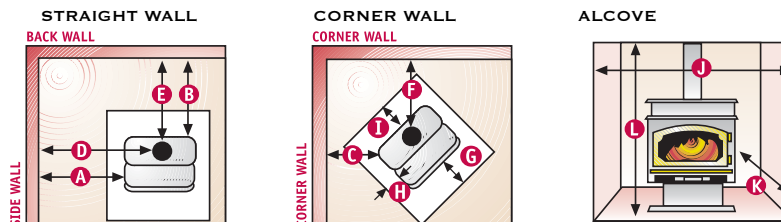

*HEATING CAPACITY MAY VARY DEPENDING ON DEGREE OF HOME INSULATION, FLOOR PLAN AND AMBIENT TEMPERATURE ZONE OF THE AREA IN WHICH YOU LIVE.

TRAVIS INDUSTRIES WOOD PRODUCTS



Lopi Wood Burning Stoves LEYDEN

EPA Emissions	Overall Efficiency	Maximum Btu s/Hour**	Firebox Size	Heating Capacity*	Maximum Burn Time**	Maximum Log Length	Wood Capacity	Weight
2.4 Grams/Hr.	70 %	73,100	2.3 Cu. Ft.	Up to 2,000 Sq. Ft.	Up to 12 to 18 Hours	Up to 21 inches	45-65 Pounds	375 Lbs.

* Heating Capacity may vary depending on the degree of home insulation, floor plan, ambient temperature zone of the area in which you live.

** BTU Output and Burn Times may vary depending on moisture content of wood, wood type, chimney draft and oxygen supply.

DIMENSIONS

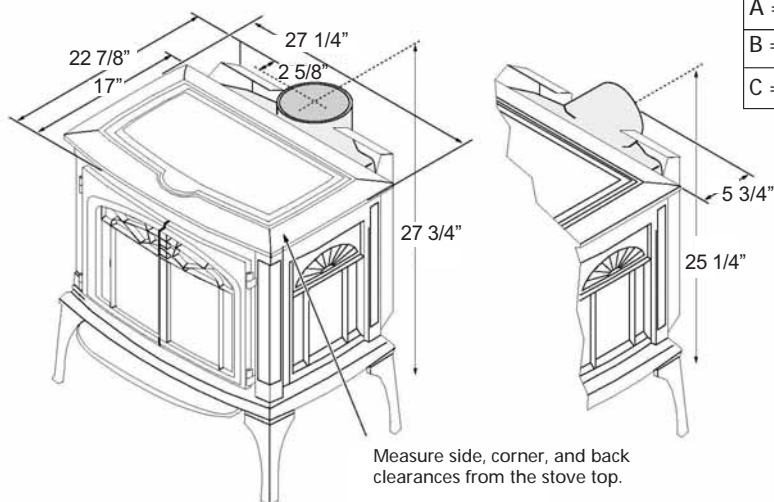

Measure side, corner, and back clearances from the stove top.

ALCOVE CLEARANCES

A = Maximum Depth	48	Measured From Combustible Surfaces
B = Maximum Width	63 1/4	
C = Minimum Height	84	

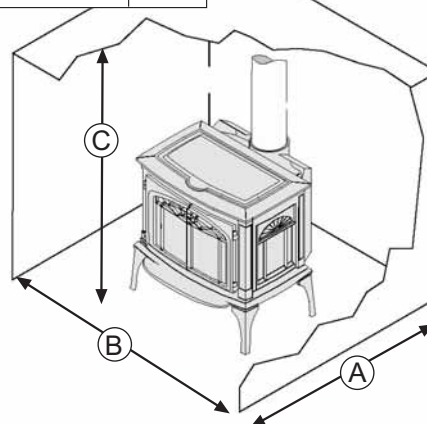

CLOSE CLEARANCES TO COMBUSTIBLES

(Rear heat shield is a standard feature)

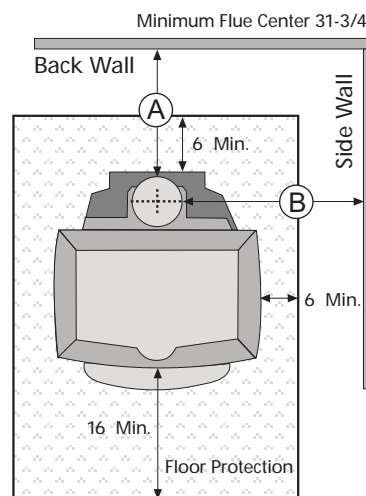

Minimum Flue Center 31-3/4
 Typical flue center Single Wall 24
 Reduced Clearance 17.5
 Single Wall with Pipe Shield 14

	Single Wall Connector	Single Wall Connector w/Pipe Shield	Double Wall Connector
A =	21	11	14
B =	28 3/4	28 3/4	28 1/4
C =	23	18	17 1/2
D =	19	14	14

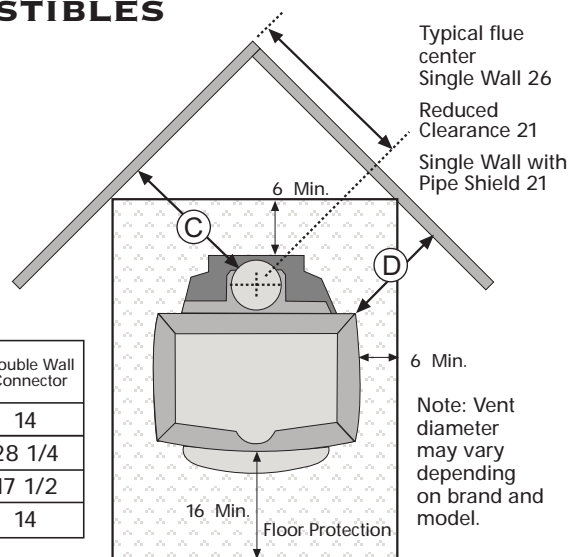

Measure front clearances from the face of the stove (door opening).

Measure rear and side clearances from the nearest edge of the stove top.

Measure rear and side clearances from the nearest edge of the stove top.

Measure front clearances from the face of the stove (door opening).

TRAVIS INDUSTRIES WOOD PRODUCTS



TRAVIS INDUSTRIES
HOUSE OF FIRE

Lopi Wood Burning Inserts

ANSWER REVERE DECLARATION FREEDOM FREEDOM BAY
ZERO CLEARANCE APPROVED ZERO CLEARANCE APPROVED

	SMALL	MEDIUM	LARGE
SPECIFICATIONS			
WIDTH	23 5/8"	24 1/4"	28 7/8"
HEIGHT	20 3/4"	19 3/4"	21 1/2"
DEPTH (OVERALL)	16 1/4"	23 1/8"	21 3/4"
DEPTH ON HEARTH	3"	10"	1 1/4"
DEPTH INTO FIREPLACE	13 1/2"	13 1/8"	20 1/2"
FLUE SIZE	6"	6"	6"
CONSTRUCTION (PLATE STEEL)	5/16" TO 3/16"	5/16" TO 3/16"	5/16" TO 1/4"
WEIGHT (BODY)	300 LBS.	380 LBS.	450 LBS.
PERFORMANCE			
EMISSIONS	4.4 GRAMS/HR.	1.9 GRAMS/HR.	4.1 GRAMS/HR.
HEATING CAPACITY	750 TO 1,200 Sq. Ft.	1,200 TO 2,000 Sq. Ft.	1,200 TO 2,000 Sq. Ft.
HEAT OUTPUT (CORD WOOD)	66,800 BTU'S/HR.	72,400 BTU'S/HR.	73,300 BTU'S/HR.
EFFICIENCY (DEQ)	UP TO 79.6%	UP TO 78.8%	UP TO 76.9%
MAXIMUM BURN TIME	UP TO 8 HOURS	UP TO 10 HOURS	UP TO 12 HOURS
FIREBOX SIZE	1.6 CUBIC FT.	2.2 CUBIC FT.	2.9 CUBIC FT.
MAXIMUM LOG SIZE	18"	18"	24"
CLEARANCES	MASONRY FIREPLACE METAL (ZC) FIREPLACE	MASONRY FIREPLACE METAL (ZC) FIREPLACE	MASONRY FIREPLACE MASONRY FIREPLACE EXTENDED W/FLUSH KIT MASONRY FIREPLACE
A= FIREBOX TO MANTEL = WITH MANTEL SHIELD	15 1/2" 24"	30 1/2" 24"	41 1/2" (MEASURED FROM FLOOR) 32" 20"
B= FIREBOX TO TOP FACING = WITH MANTEL SHIELD	12" 12"	28 1/2" 12"	39" (MEASURED FROM FLOOR) 30" 20"
C= FIREBOX SIDE TO SIDE FACING	9 1/2" 12"	13" 12"	9" 13 1/2" 13 1/2"
D= FIREBOX SIDE TO SIDE WALL	13" 30"	15" 30"	9" 15" 15"
FIREPLACE SIZING	MASONRY FIREPLACE METAL (ZC) FIREPLACE	MASONRY FIREPLACE METAL (ZC) FIREPLACE	MASONRY FIREPLACE MASONRY FIREPLACE EXTENDED W/FLUSH KIT MASONRY FIREPLACE
E= MINIMUM DEPTH	13 1/2" 14 1/2"	13 1/8" 14 1/8"	20 1/2" 32" 20"
F= MINIMUM FRONT WIDTH	23 5/8" 25 5/8"	24 1/4" 26 1/4"	30 7/8" 29 1/4" 29 1/4"
G= MINIMUM BACK WIDTH	23 5/8" 25 5/8"	21 5/8" 23 5/8"	21 1/4" 21 1/4" 21 1/4"
H= MINIMUM HEIGHT	20 3/4" 20 3/4"	19 3/4" 19 3/4"	21 1/2" 21 3/4" 21 3/4"
PANEL SIZES			
RECTANGULAR PANELS LISTED.			ASK YOUR DEALER FOR SIZING ON ARCHED PANELS. (FREEDOM ONLY)
8" x 8"	28 1/4" H x 40 1/8" W	27 5/8" H x 40 3/8" W	29 1/2" H x 45 1/2" W
10" x 10"	30 1/4" H x 44 1/8" W	29 5/8" H x 44 3/8" W	31 1/2" H x 49 1/2" W
12" x 12"	N/A	31 5/8" H x 48 3/8" W	33 1/2" H x 53 1/2" W
			29 1/2" H x 45 3/8" W
			31 1/2" H x 49 3/8" W
			33 1/2" H x 53 3/8" W

CLEARANCES TO UNPROTECTED COMBUSTIBLES:

USE THESE ILLUSTRATIONS IN CONJUNCTION WITH THE INFORMATION UNDER THE "CLEARANCE" & "ALCOVE" HEADINGS ABOVE.

ALL INSERTS EXCEPT THE DECLARATION MUST HAVE A NON-COMBUSTIBLE HEARTH PAD THAT EXTENDS A MINIMUM OF 16" IN FRONT OF THE INSERT AND 6" TO THE SIDES.

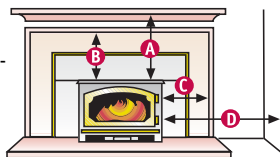

THE DECLARATION MUST HAVE A NONCOMBUSTIBLE HEARTH PAD THAT EXTENDS A MINIMUM OF 17 1/4" IN FRONT OF THE LOPI INSERT AND 8" TO THE SIDES.

SIZING YOUR FIREPLACE FOR AN INSERT:

USE THESE ILLUSTRATIONS IN CONJUNCTION WITH THE INFORMATION UNDER THE "FIREPLACE SIZING" HEADINGS ABOVE.

PLEASE USE THE PROVIDED CHART ON THE RIGHT TO MARK DOWN YOUR FIREPLACE DIMENSIONS. THIS WILL ASSIST YOU IN DETERMINING THE RIGHT LOPI INSERT FOR YOUR FIREPLACE.

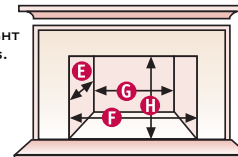

APPROVED ZC FIREPLACES:

THE ANSWER AND ENDEAVOR INSERTS ARE APPROVED FOR MARCO, MAJESTIC, HEATILATOR, SUPERIOR, PREWAY AND TEMPKO ZERO CLEARANCE FIREPLACES. SEE THE OWNER'S MANUAL FOR DETAILS.

YOUR FIREPLACE MEASUREMENTS

- E. _____
- DEPTH
- F. _____
- FRONT WIDTH
- G. _____
- BACK WIDTH
- H. _____
- HEIGHT

TRAVIS INDUSTRIES WOOD PRODUCTS



33 Elite Wood Burning Insert

EPA Phase II Approved 4.1 Grams/Hour	Maximum Btu's Per Hour 73,300	Overall Efficiency 71.1%	Heating Capacity 1,200 to 2,000 Sq. Ft.	Up To 12 Hour Burn Time	Accepts 24" Wood	2.9 Cubic Foot Firebox	Heavy Gauge Plate Steel Construction 5/16" & 1/4"	Heavy-Duty Masonry Lined Firebox & Baffle	180 CFM Convection Blower Standard
---	----------------------------------	-----------------------------	--	-------------------------	------------------	------------------------	--	---	------------------------------------

Dimensions

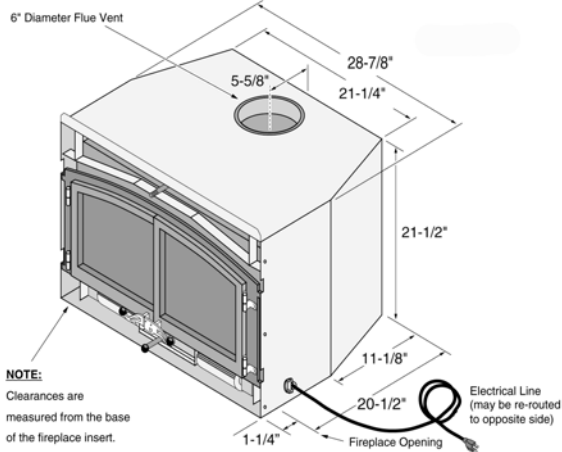

Installation

We suggest that you have an authorized Fireplace Xtordinaire dealer install your fireplace insert. If you install the fireplace insert yourself, your authorized dealer should review your installation plans.

The 33 Elite Wood Insert is designed for installation in masonry fireplaces. Do not install into a factory-built metal (Z.C.) fireplace.

Check with your local building officials for any permits required for installation of this fireplace insert and notify your insurance company before proceeding with installation.

The 33 Elite must be installed with either Positive Flue (full chimney reline) or Direct Connect Flue (See Owner's Manual for details).

Testing

Tested and certified by OMNI-Testing Laboratories Inc.
Report # 028-S-54-2 Safety Tested to U. L. 1482

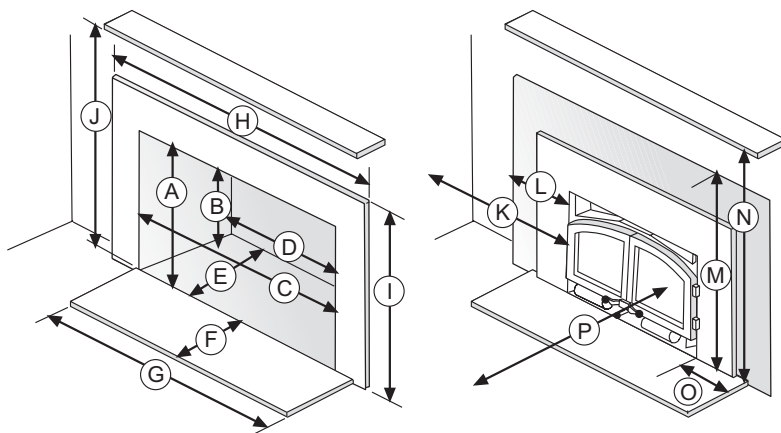

Minimum Fireplace Size

A - Height (Front)	21 1/2"
B - Height (Rear)	21 1/2"
C - Width (Front)	30 7/8"
D - Width (Rear)	21 1/4"
E - Depth	20 1/2"
F - Hearth Depth	17 1/4"
G - Hearth Width	44 7/8"
H - Facing Width	46 7/8"
I - Facing Height	39"
J - Mantel Height	41 1/2"

Surround Panels

The surround panels are designed to finish off the fireplace opening. Surround panels can also be custom cut to fit the inside dimensions of your fireplace opening.

- 8" Panel Set - Covers 45 1/2" Wide x 29 1/2" Height
- 10" Panel Set - Covers 49 1/2" Wide x 31 1/2" Height
- 12" Panel Set - Covers 53 1/2" Wide x 33 1/2" Height

Minimum Clearances to Combustibles

K - Sidewall To Insert	9"
L - Side To Facing	9"
M - Top Facing	39"
N - Mantle	41 1/2"
O - Hearth (Side)	8"
P - To Any Room Combustible (i.e. chair, curtains)	36"

TRAVIS INDUSTRIES WOOD PRODUCTS



36 & 44 Elite Wood Burning Fireplaces

Features & Specifications	Model 36 Elite Zero Clearance	Model 44 Elite Zero Clearance
EPA Phase II Approved	YES	YES
Overall Efficiency*	73%	72%
Heating Capacity	Up to 2,500 Sq./Ft.	Up to 3,000 Sq./Ft.
Emissions**	2.3 Grams/Hour	2.5 Grams/Hour
Maximum Burn Time [^]	10 Hours	12 Hours
Flue	8" Opening I.D.	8" Opening I.D.
Overall Width	42"	48"
Overall Depth	27"	27"
Firebox Capacity	3.7 Cubic Feet	4.3 Cubic Feet
Wood Size	24"	32"
BTU Output Cordwood	10,300 to 66,000 Per/Hr.	10,700 to 76,700 Per/Hr.

*DEQ Method **EPA Method Not Including Faceplate

[^] Emissions, Efficiency, Heating Capacity and Burn Time may vary depending on actual home floor plan, type of fuel used, and moisture content. Emissions numbers are those that have been certified by the U.S. E.P.A. BTU output based on burning cordwood. Efficiency numbers are based on Oregon Dept. of Environmental quality test standards.

Framing Specifications

Please consult your Owner's Manual for Framing Specs.

	36 Elite	44 Elite
A =	45 1/2"	50 1/2"
B =	26"	26"
C =	43"	50"

NOTE: Make sure the enclosure is wide enough to accommodate the blower (see Owner's Manual for details).

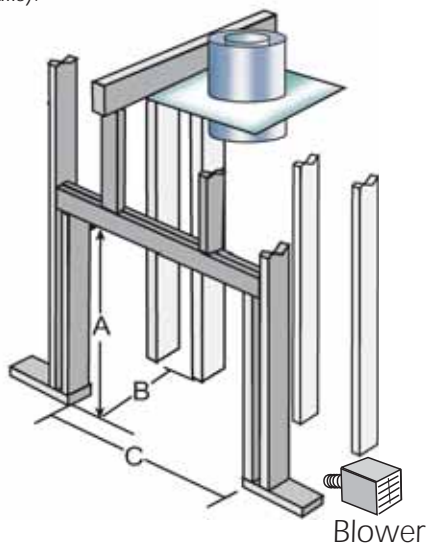

Clearance Specifications

To Combustible Mantle:

23" from fireplace face.

To Combustible Facing:

Top Facing 12" - Side Facing 2 1/2" from fireplace face.

Hearth:

Requires a 20" non-combustible hearth.

Approved Air-Cooled Chimney:

FMI 8HT & Firecraft FTF8 A

Improper installation of your wood burning fireplace or failure to operate it according to the guidelines detailed in the Owner's Manual, may negate your warranty and endanger your home and family. Contact your local building or fire officials about restrictions and installation requirements in your area.

Model 36 Elite Zero Dimensions

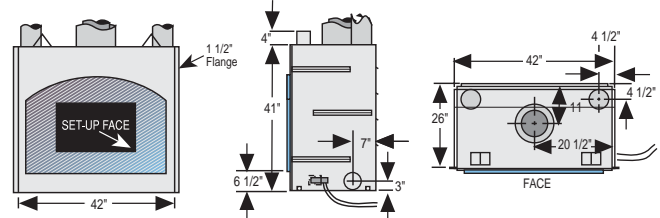

Model 44 Elite Zero Dimensions

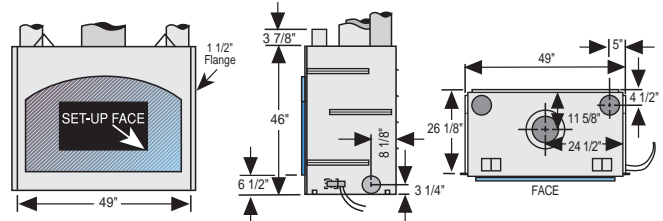

- Unibody construction
- Single Air Control
- Minimum clearances to combustibles
- Operation/Care manual and touch-up paint
- Easy start-up and refueling with bypass damper (most models)
- Non-Catalytic EPA Phase II clean burning
- 6" flue on all models
- 3/16" - 1/4" - 5/16" steel construction
- Long burn times
- Easy operation cam lever door lock

TRAVIS INDUSTRIES WOOD PRODUCTS



- One out of every five woodstoves sold in North America is a Travis product
- “Real World” seven year warranty
- Clean burn airwash
- Replaceable air tubes, firebrick baffle and baffle retainers
- Radiant and convection heaters (3 and 5 sides to convection chamber)
- Heats up to 2,500 Sq. Ft.
- Clearview ceramic glass
- Clay, kiln fired firebrick

Wood As Fuel

- Wood is renewable natural resource.
- Wood is a hydrocarbon, or in other words - it is made up of hydrogen and carbon atoms.

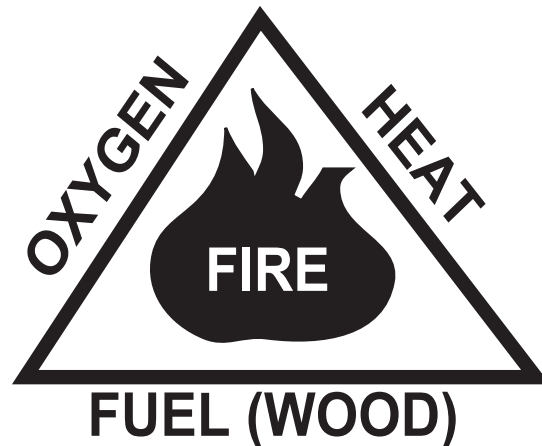

- Combustion of wood takes place when we mix the right quantities of fuel (wood), heat & oxygen.
- When proper balance exist between these items complete combustion takes place and produces:
 - Water Vapor
 - Carbon Dioxide
 - Heat
 - Non-Combustible Ash

Wood As Fuel

STAGES OF WOOD COMBUSTION

STAGE 1 - Moisture Evaporation

- The wood is heated and the contained moisture evaporates to form steam.
- **NO HEAT** is given off - it is all absorbed in drying out the wood.

STAGE 2 - Vaporization of Hydrocarbon Compounds

- The chemical structure of wood molecules begin to breakdown and hydrocarbons begin to vaporize. This process is known as pyrolysis.
- During pyrolysis liquid tar droplets and combustible gas are produced from the hydrocarbons.
- This stage is still absorbing heat rather than giving off heat.

Wood As Fuel

STAGES OF WOOD COMBUSTION

STAGE 3 - Gas Vapor Ignition & Combustion

- Gases and tar droplets produced in stage two, ignite in stage 3. They ignite between the temperatures of 540°F to 1225°F.
- Temperatures in the firebox may reach upwards of 2000°F during this stage of burning.

STAGE 4 - Char Burning

- After pyrolysis, moisture evaporation, and the release of gases have subsided (about 950°F), the char burning stage begins.
- The carbon in charcoal is the only remaining combustible material. Charcoal burns with little or no flame and produces temperatures of about 1100°F.

Emissions

- Over the years, air quality has become an issue and wood burning products were sited as contributing to poor air quality.
- In 1990, EPA (Environmental Protection Agency) became the agency to regulate the emissions of wood products.
- Today's EPA particulate emission standards are:
 - Catalytic products
4.1 Grams/Hour
 - Non-Catalytic products:
7.5 Grams/Hour
- Most states follow the EPA standard however states may have more stringent requirements.
- Washington State is one of those States:
 - Catalytic products
2.5 Grams/Hour
 - Non-Catalytic products:
4.5 Grams/Hour

Emissions

- Wood burning products must adhere to the EPA emissions standards having the following characteristics.
 1. Minimum burn rate less than 5 grams/hour (11 lbs.)
 2. Average air-to-fuel ratio of less than 35 to 1.
 3. Usable firebox of less than 20 cubic feet.
 4. Weigh less than 800 kilograms (about 1760 lbs.)

EPA EMISSION TESTING

- EPA tests follow a very specific, stringent protocol. All of the smoke from the wood burning appliance is drawn through a filter before exiting up the chimney.
- The stove is burned in a series of 4 tests all at different burn rates.
- In each test the filter is weighed before the test and is dried and weighted at the conclusion of each test. The difference is the stated grams/hour of particulate emission.
- The combined tested emissions for all 4 burn tests is then averaged. The averaged total **MUST** meet or be below the EPA standard in order for the stove to get a EPA certification.

EPA Hang Tag

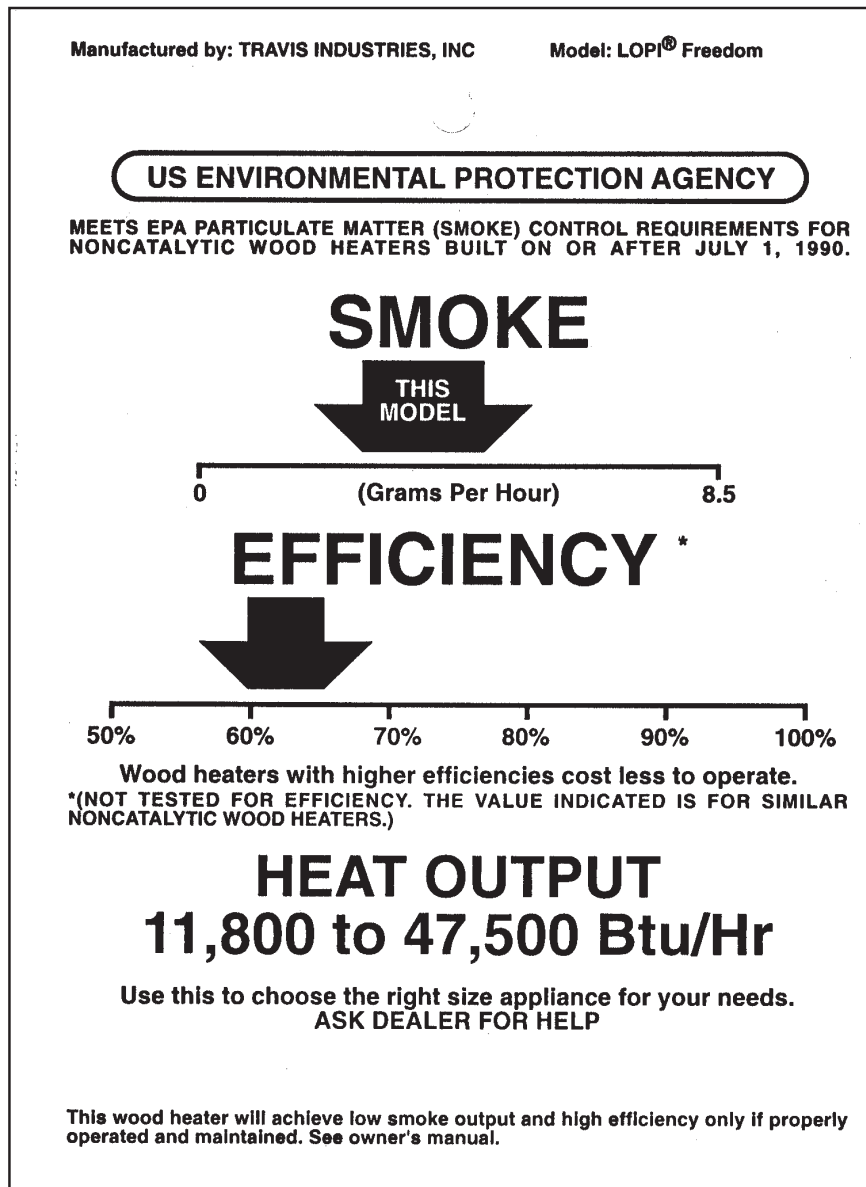

- EPA hang tags must be present ON each woodburning in your showroom.
- Non-compliance may result in a \$5,000 fine per unit.

Wood Combustion

- The three T's are critical to high efficiencies.
- Time, Temperature and Turbulence of the flue gases.
- Our stoves are designed and constructed to provide maximum residence time of the flue gas at a good mix of primary and secondary air.

“T” Factor	Accomplished By:
Time	<ul style="list-style-type: none">• Firebrick Free Floating Baffle• Single Air Control
Temperature	<ul style="list-style-type: none">• Firebrick Baffle
Turbulence	<ul style="list-style-type: none">• Primary Air• Glass Door Airwash• Secondary Air

Stove Construction

- The Three T's
 1. EFFICIENCY
 2. "GOOD HEAT"
 3. TRANSFER

ACCOMPLISHED BY
- Use of clay fired firebrick - conducts the heat through the brick lining to the convection chambers.
- Use of clear view Neoceram™ glass - reflects the heat through the glass door into the room.
- Use of large radiant surfaces.

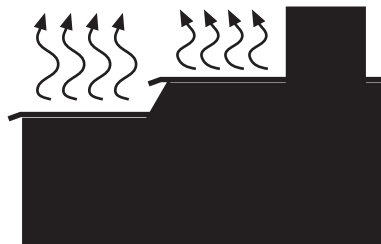

- Use of three and five-sided convection chambers.

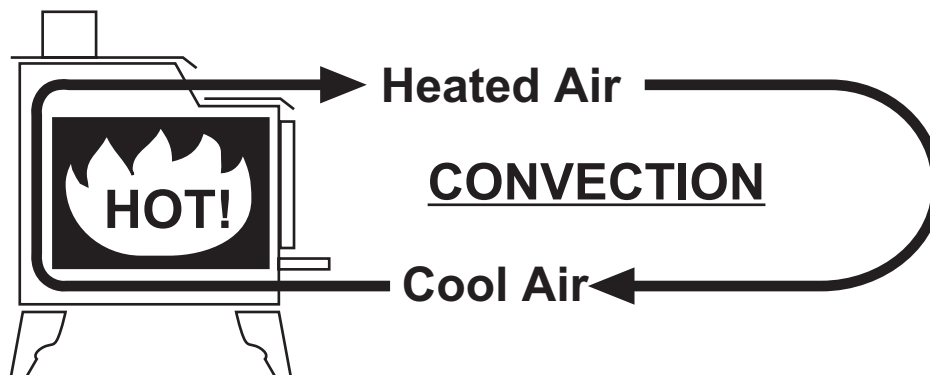

- Three-sided convection- Heat is washed off of the bottom, back and top.
- Five-sided convection - Heat is washed off of the bottom, back, top and two sides.

Wood Stove Venting

- The pipe which connects the stove to the chimney is called a connector.
- The stove connector must connect to a masonry chimney or a metal factory built type UL103 HT chimney.
- Connectors must never pass through a wall or ceiling. Stove connectors may be single wall pipe or double wall pipe with an air space between the inner and outer wall.
- The system shall not have more than 180° of turn (2-90° elbows or 1-90° elbow and 2-45° elbows).
- Chimney must be masonry constructed in accordance with NFPA 211 standards or factory built chimney tested to the UL103 HT standard.

Single Wall Connector



**Single Wall
Pipe**



**Single Wall Slip
Connector**



**Single Wall
Elbow**

• Single Wall Connector

Construction	<ul style="list-style-type: none"> • 24 MSG Black or 26 MSG Blued Steel
Lengths	<ul style="list-style-type: none"> • 12"-24"- 48" Slip connector which allows for 10" adjustment
Advantages	<ul style="list-style-type: none"> • Radiates heat into room • Inexpensive
Disadvantages	<ul style="list-style-type: none"> • Requires 18" clearance to combustibles • Removes too much heat potentially creating creosote build-up and harder start-up

Double Wall Connector



**Double Wall
Pipe**



**Double Wall
Telescoping**



**Double Wall
Elbow**

• Double Wall Connector

Construction	<ul style="list-style-type: none"> • Stainless steel inner liner - Galvanized outer shell
Lengths	<ul style="list-style-type: none"> • 6"-12"-18"-24"- 48" • Telescoping 29"to48' & 40' to 68"
Advantages	<ul style="list-style-type: none"> • Close clearance reduction NOTE: Only listed, tested close clearance connectors may be used on Travis wood products. Must be used for close clearance, alcove and mobile home installations. • Keeps chimney cleaner as flue stays hotter. • Makes for easier start-up of the fire
Disadvantages	<ul style="list-style-type: none"> • More expensive

Factory Built Chimney

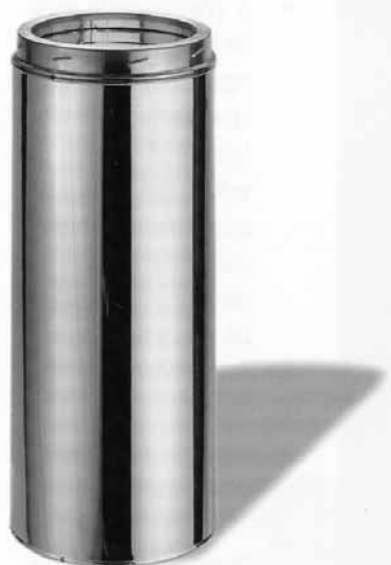

• Factory Built Chimney

Construction	<ul style="list-style-type: none">• Stainless steel inner and stainless steel or galvanized outer with blanket insulation in between inner and outer and or air space
Lengths	<ul style="list-style-type: none">• 6"-12"-18"-24"-36"-48"
Listings	<ul style="list-style-type: none">• UL103 HT listing 2100°

Chimney Requirements

- **DO NOT CONNECT THIS UNIT TO A CHIMNEY FLUE SERVING ANOTHER APPLIANCE.**
- Chimney connector must be a minimum 24 MSG black or 26 MSG blued steel (6" diameter). Chimney must be used from the first floor or wall penetration to the chimney cap.
- Use 6" diameter type UL 103 HT chimney from one manufacturer (do not mix brands) or code approved masonry chimney with a flue liner.
- Chimney connector and chimney must be fastened to the stove and each adjoining section.
- Follow the chimney manufacturer's clearances and requirements.
- Use the chimney manufacturer's fire stops, attic guards, roof supports, and flashings when passing through a ceiling or thimble when passing through a combustible wall.
- No more than 180° of elbows (two 90° elbows, or two 45° & one 90° elbow, etc.).

NOTE: Additional elbows may be allowed if draft is sufficient. Whenever elbows are used the draft is adversely affected. Additional chimney height may be required to boost draft.

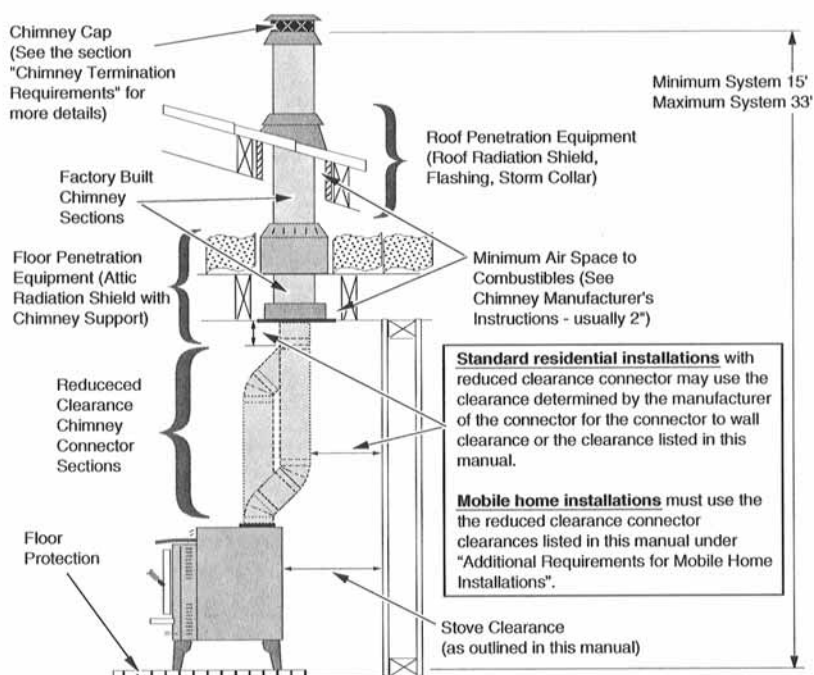

Drafting Performance This appliance relies upon natural draft to operate. External forces, such as wind, barometric pressure, topography, or factors of the home (negative pressure from exhaust fans, chimneys, air infiltration, etc.), may adversely affect draft. Travis Industries can not be responsible for external forces leading to less than optimal performance.

- Standard residential installations may use single-wall connector (Mobile-Homes may **not**)
- Standard residential installations with reduced clearance connector may use the clearance determined by the manufacturer of the connector for the connector to wall clearance or the clearance listed in this manual. Offsets must be used to maintain the stove to wall clearance. Mobile homes must use the clearances listed in this manual under "Additional Requirements for Mobile Home Installations".

Alcove Installation Requirements

Whenever the stove is placed in a location where the ceiling height is less than 7' tall, it is considered an alcove installation. Because of the reduced height, the special installation requirements listed below must be met.

- Chimney connector and chimney must be one of the following types:
 - DURAVENT model DVL with DURATEC chimney
 - DURAVENT model DVL with DURA-PLUS chimney
 - AMERI-TEC model DCC with model HS chimney
 - SECURITY model DL with SECURITY model ASHT or S2100 chimney
 - METAL-FAB model DW with TG chimney
 - GSW Double Wall Chimney Connector with Super Chimney Twenty-One
 - SELKIRK METALBESTOS model DS connector with model SSII chimney
 - I.C.C. Excel (2100-2 Can.) (103-HT USA) chimney with HP connector
 - Standard Masonry Chimney with any one of the above listed connectors

Minimum Clearance (See the illustration below)	Pendleton-45°		Pendleton-90°	
	Combustible Alcove	Non-Combustible Alcove	Combustible Alcove	Non-Combustible Alcove
A Sidewall to stove	11"	6"	11"	6"
B Backwall to stove	13"	5"	8 1/2"	2"
D Connector to sidewall	19 1/2"	14 1/2"	19 1/2"	14 1/2"
E Connector to backwall	9"*	2 1/2"*	8 3/4"	2 1/4"
G Maximum depth of alcove	48"	48"	48"	48"
H Minimum width of alcove	45 3/4"	35 3/4"	45 3/4"	35 3/4"
J Minimum height of alcove	84"	6" above stove top	84"	6" above stove top

- Alcoves are classified as combustible or non-combustible. Non-combustible alcoves must have walls and a ceiling that are 3 1/2" thick of a non-combustible material (brick, stone, or concrete). This non-combustible material must be spaced and ventilated at least 1" off of all combustible materials (walls, ceiling, etc.) to allow air to move around the non-combustible walls and ceiling. All other alcoves are considered combustible. The clearances below must be met:

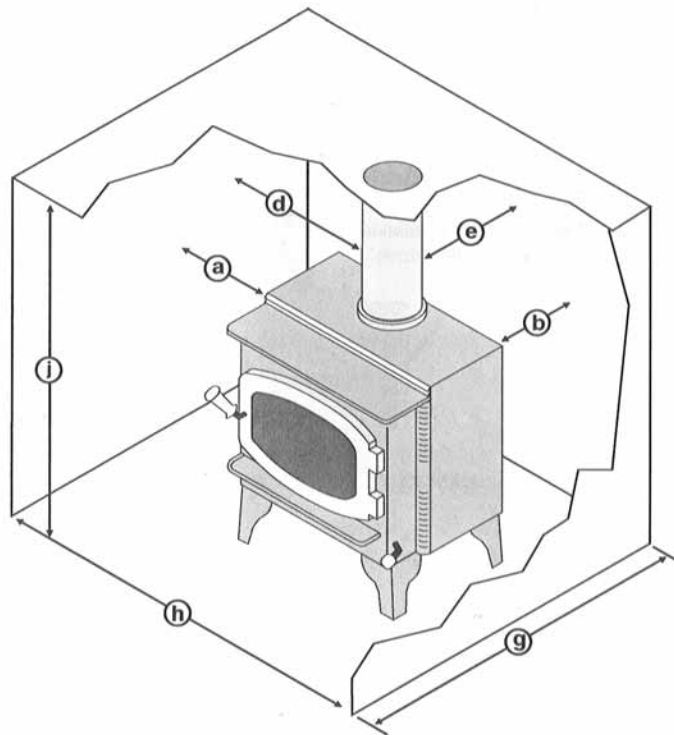
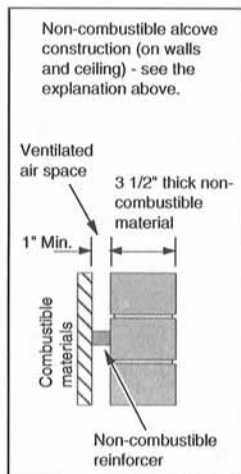

TRAVIS INDUSTRIES WOOD PRODUCTS



TRAVIS INDUSTRIES
HOUSE OF FIRE

Mobile Home Requirements

- Outside air must be installed - see "Outside Air Requirements" on page 11
- Chimney connector and chimney must be one of the following types:
 - DURAVENT model DVL with DURATEC chimney
 - DURAVENT model DVL with DURA-PLUS chimney
 - AMERI-TEC model DCC with model HS chimney
 - SECURITY model DL with SECURITY model ASHT or S2100 chimney
 - METAL-FAB model DW with TG chimney
 - GSW Double Wall Chimney Connector with Super Chimney Twenty-One
 - SELKIRK METALBESTOS model DS connector with model SSI chimney
 - I.C.C. Excel (2100-2 Can.) (103-HT USA) chimney with HF connector
 - Standard Masonry Chimney with any one of the above listed connectors

NOTE: Reduced clearance connectors may not connect to the flue collar – order an appliance adapter for the connector being used.

- Stove placement must maintain the following clearances to combustibles (drywall, furniture, etc.)

Minimum Clearance (See the illustration below)	745 Reduced Clearance Connector	790 Reduced Clearance Connector
A Sidewall to stove	11"	11"
B Backwall to stove	13"	8 1/2"
C Cornerwall to stove	7 1/2"	7 1/2"
D Connector to sidewall	19 1/2"	19 1/2"
E Connector to backwall	9"*	8 3/4"
F Connector to cornerwall	11"*	15"

* These are minimum clearances, not installation dimensions. Connector position will vary depending upon brand. First establish the stove clearances, install the 45° connector to the stove, then determine the position of the connector.

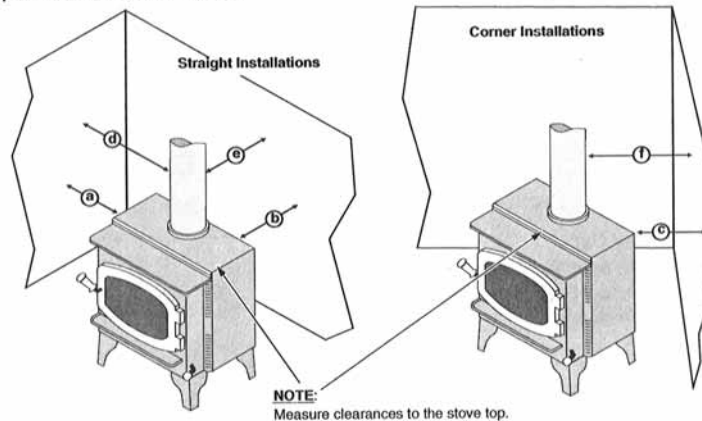

- If using offsets, use the connector clearance listed to the right, **not the connector manufacturer's clearance.**
- The appliance must be secured to the floor (consult your building official). Secure the outside air boot to the floor and stove to insure the stove does not dislocate.
- Mobile home installations require a spark arrester at the chimney termination.
- The appliance must be grounded to the chassis of the mobile home (consult your building official).

WARNING: DO NOT INSTALL IN SLEEPING ROOM.

CAUTION: THE STRUCTURAL INTEGRITY OF THE MOBILE HOME FLOOR, WALL, AND CEILING/ROOF MUST BE MAINTAINED.

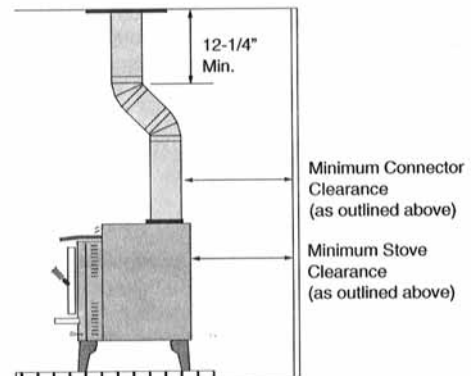

TRAVIS INDUSTRIES WOOD PRODUCTS



TRAVIS INDUSTRIES
HOUSE OF FIRE

Insert with Positive Connection

NOTE:

Most factory-built chimney manufacturers make stainless steel chimney liners, either flexible or rigid. This provides a wide variety of installation options. Make sure to follow the manufacturer's instructions for installation and support.

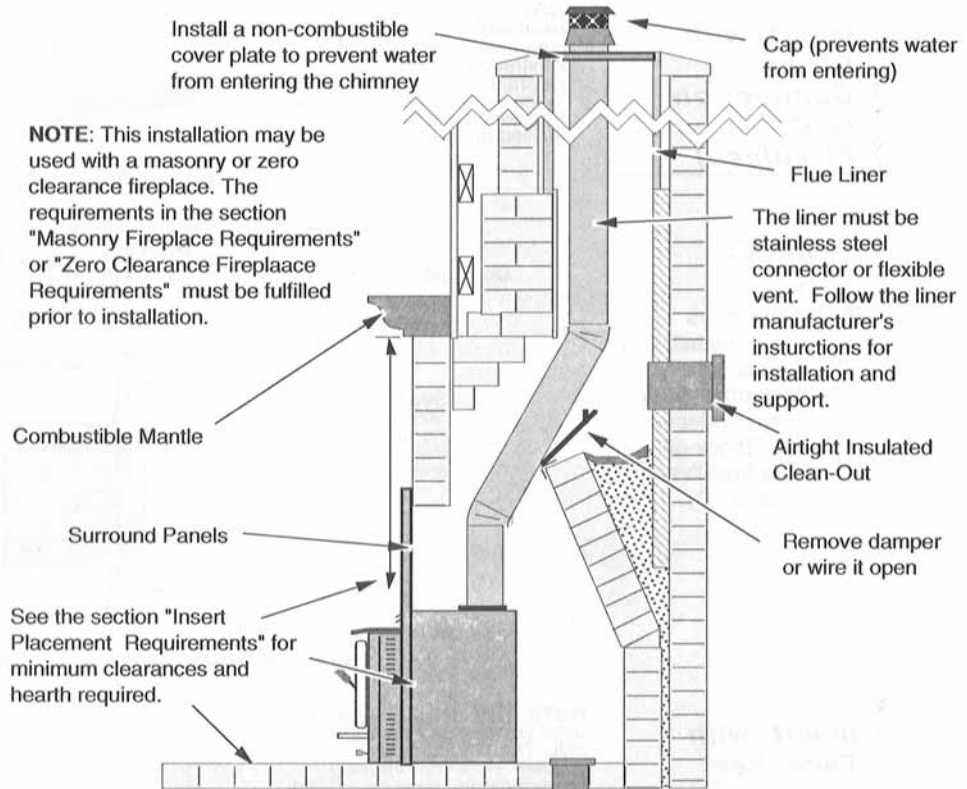

Insert with Direct Connection (Masonry Fireplace)

NOTE:

Direct connections require installation of an airtight block-off plate or damper adapter (see "Block-off Plate Installation" on page 20).

NOTE: This installation may be used with a masonry or zero clearance fireplace. This illustration depicts a masonry insert, all requirements in the section "Masonry Fireplace Requirements" must be fulfilled prior to installation.

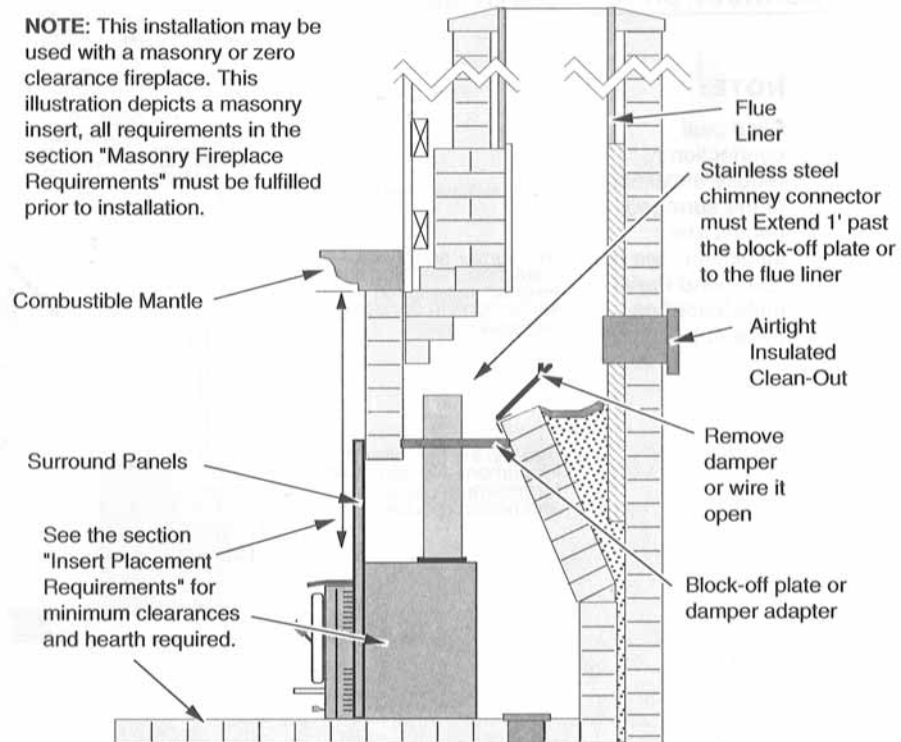



Insert with Direct Connection (Z.C. Fireplace)

NOTE:

Direct connections require installation of an airtight block-off plate or damper adapter (see "Block-off Plate Installation" on page 20).

NOTE: This installation may be used with a masonry or zero clearance fireplace. This illustration depicts a zero clearance insert, all requirements in the section "Zero Clearance Fireplace Requirements" must be fulfilled prior to installation.

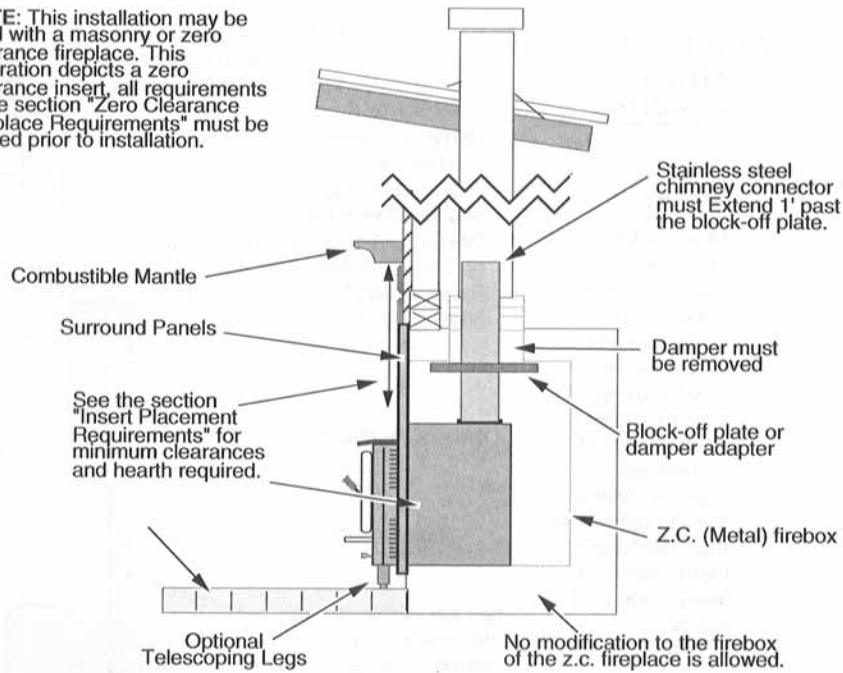

Insert with Face Seal Connection

NOTE:

Face seal connections require installation of the surround panels and insulation (see the "Surround Panel Installation" on page 42).

NOTE: This installation may be used with a masonry fireplace only. The requirements in the section "Masonry Fireplace Requirements" must be fulfilled prior to installation.

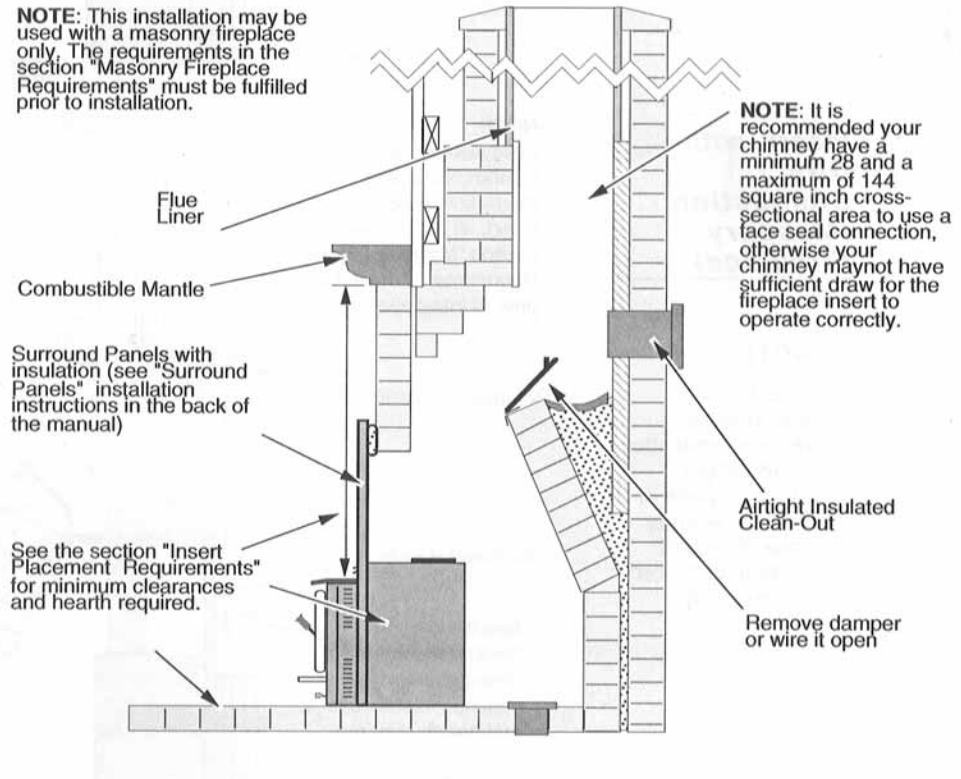

Rear Blower

Rear Blower Installation (Part number 99000138)

The rear blower improves heat transfer by pushing heated air through the convection channel. Operating instructions are described in the section "Blower Operation" on page 26.

- 1 The stove should be in place with the legs installed prior to installing the rear blower.
- 2 Follow the directions below to install the thermodisk.

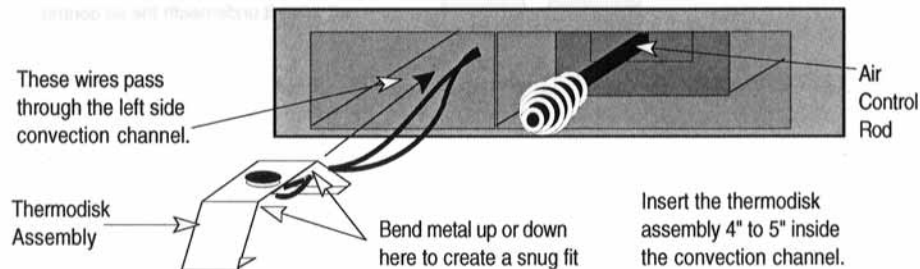

- 3 Install the wire clip following the directions below.

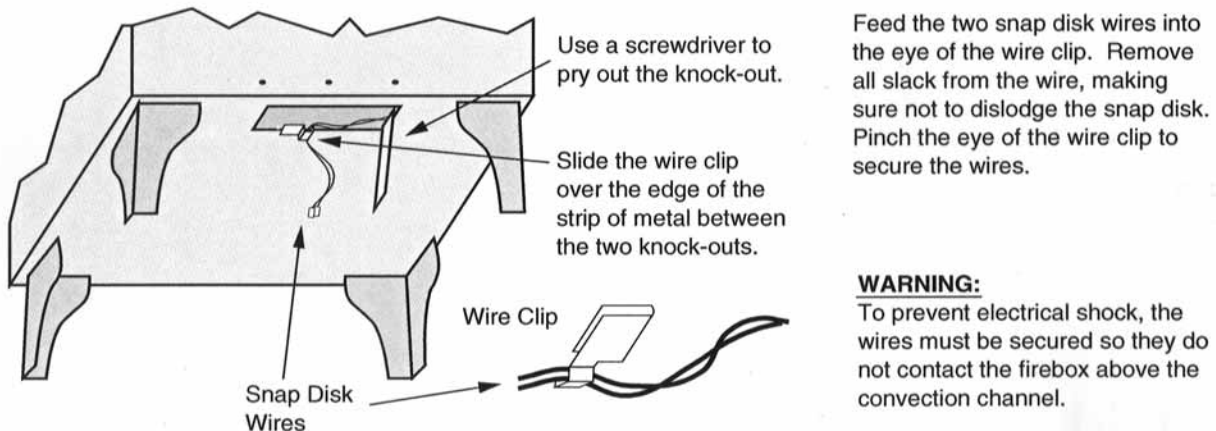

- 4 Attach the blower following the directions below.

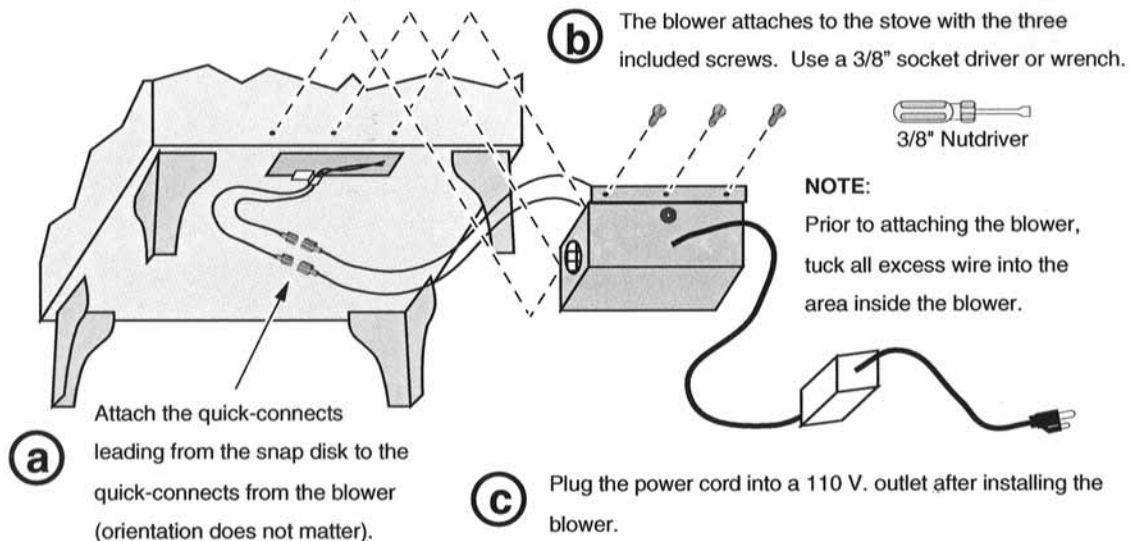

Front Blower

FRONT BLOWER INSTALLATION (PART NUMBER 99000137)

The front blower is designed to improve the natural convection of the appliance by pushing air through the convection chamber of the appliance and causing the heated air to exit through the vents along the top of the appliance. It attaches below the ashlip and can be used on appliance or insert applications. Operating instructions are described in the section "Blower Operation" on page 25. The directions below detail its installation.

1. Remove the air control handle by unscrewing the screw that holds it in place (Phillips-head).
2. Remove the knockout from the front blower (see the illustration below).

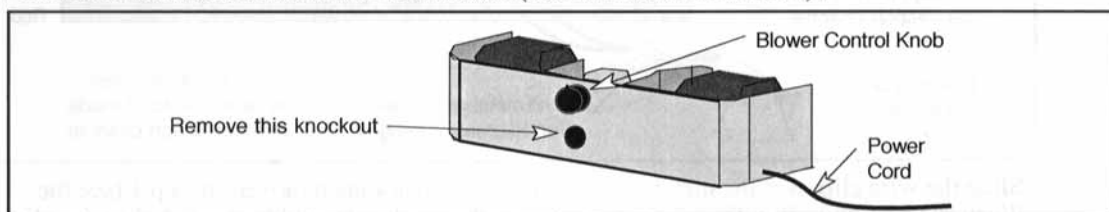

3. Place the blower underneath the ashlip so the two clips on the blower lock into the baseplate of the appliance (see the illustration below).

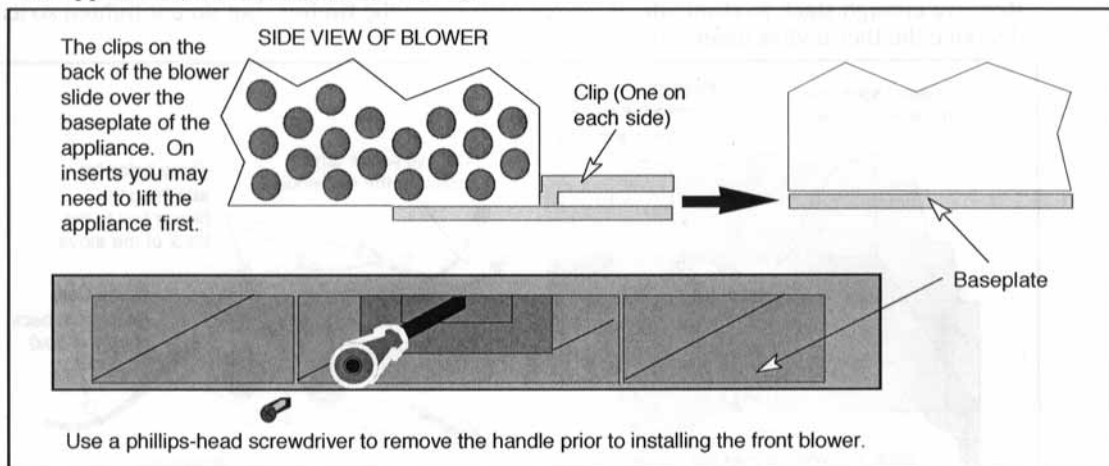

Outside Air Boot

Outside Air Boot Installation (Part number 99200134)

The outside air boot routes outside air to the stove for combustion. Refer to the section "Outside Air Requirements" on page **Error! Bookmark not defined.** for installation concerns. The directions below detail installation.

- 1 Install the cover plate following the directions below (use the cover plate that is 6-1/2" wide).

Remove the two screws on the cover plate to remove the piece that fits over the air control rod. Then replace the piece when the cover plate is in place.

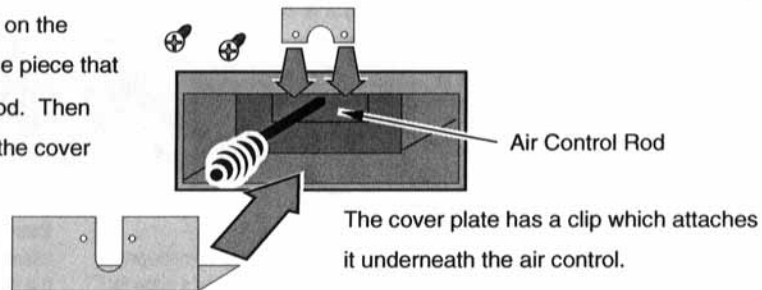

- 2 Refer to the illustration on the following page to determine the location and size of the hole penetrating the floor and. Cut the hole prior to locating the stove.
- 3 Attach gasket to the bottom edge of the lower air boot section (near the screen). Attach gasket on top of the flanges on the upper air boot section. Slide the two sections together with both seams facing the rear (do not attach the two sections at this time).
- 4 Follow the directions below for attaching the upper section of the air boot (with gasket) to the stove.
- 5 Slide the lower section down until it contacts the hearth. Attach the two sections together following the directions below

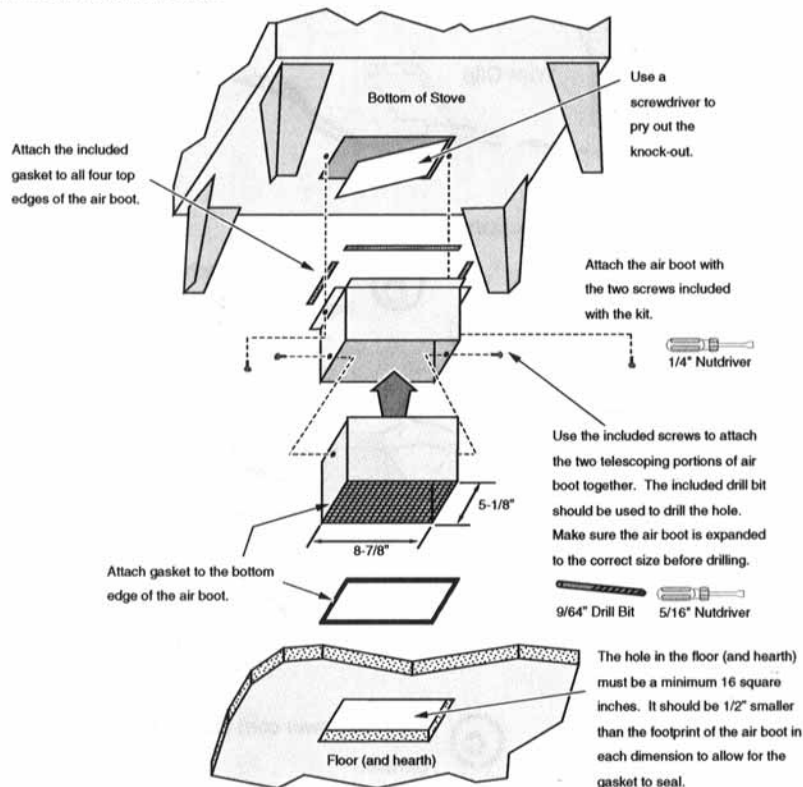

Telescoping Leg

TELESCOPING LEG INSTALLATION (PART NUMBER 99200120)

The telescoping legs are designed to support the front end of fireplace inserts on raised hearths. It is adjustable from 4 5/8" to 7 1/2". It can be cut shorter by using a hacksaw (see the illustration below).

1. Place the end caps into each lower segment of the telescoping legs (see the illustration below).
2. Screw the telescoping legs together so the leg can be screwed into the bottom of the insert. Hand tighten the telescoping leg into position.
3. While grasping the upper segment of the telescoping leg, unscrew the bottom segment until it reaches the floor and supports the insert.

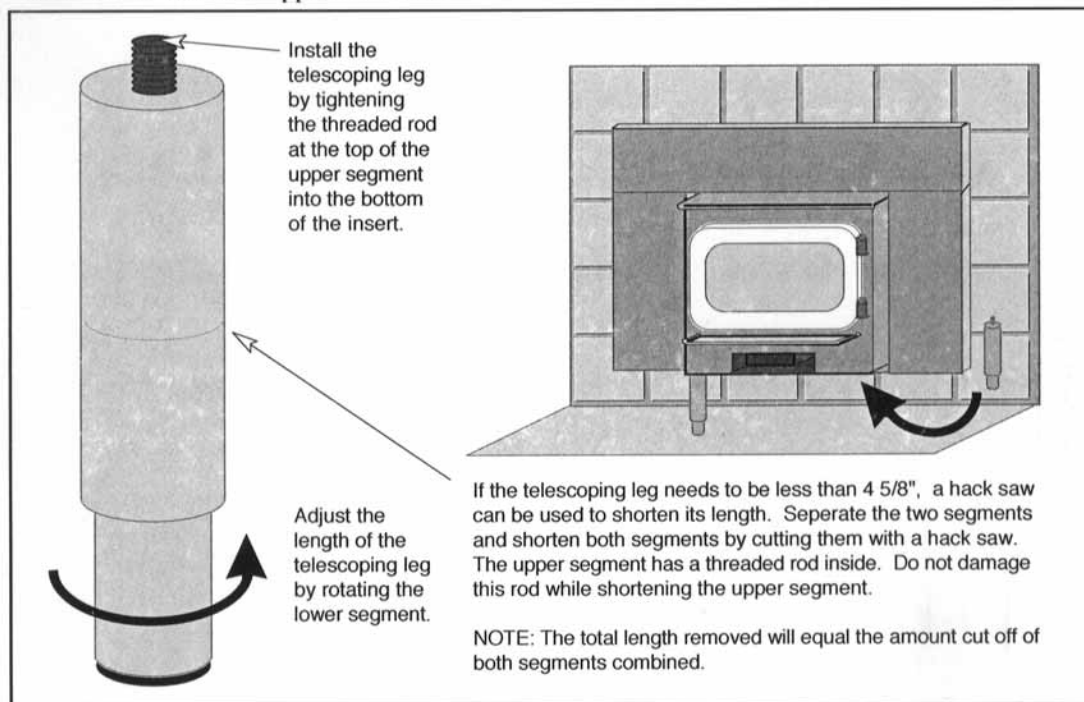

Legs

STOVE LEGS INSTALLATION (BRASS # 99200500, CAST BLACK # 99200800, BLACK STEEL # 99200100)

There are three different stove legs available for your wood stove: cast brass; cast black; and black steel. The instructions for installing the legs are the same for each type of leg.

Raise the stove by inserting some pieces of lumber in the middle of the stove to a height of about 8". Line up the hole in the top of the leg with the threaded bolt hole in each corner of the stove bottom. Using a 9/16" open end or socket wrench, fasten the leg to the stove with the supplied attachment bolts and washers, making sure the legs are flush with the corners of the stove. Unscrew the leveling bolts enough so the stove will rest on the upper tips, not the metal portion of the legs. Lower the stove down.

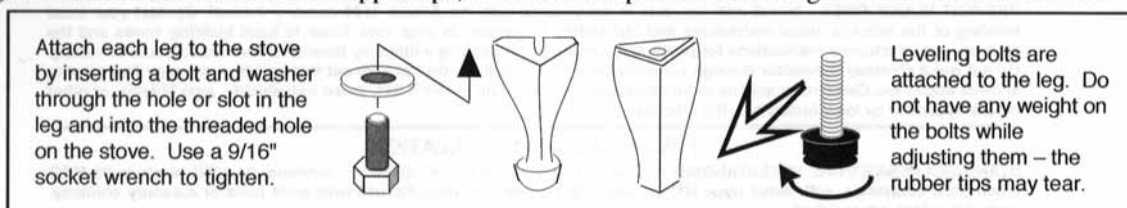

To level the stove, lift the stove up and unscrew each leveling bolt the appropriate amount. The rubber tips of the leveling bolts will tear if they are adjusted while weight is applied to them.



Cast Solid Brass

Cast Black

Sculptured Black Steel

or

Pewter*

*Lopi only

New Small Pedestals

Example Shown - Lopi

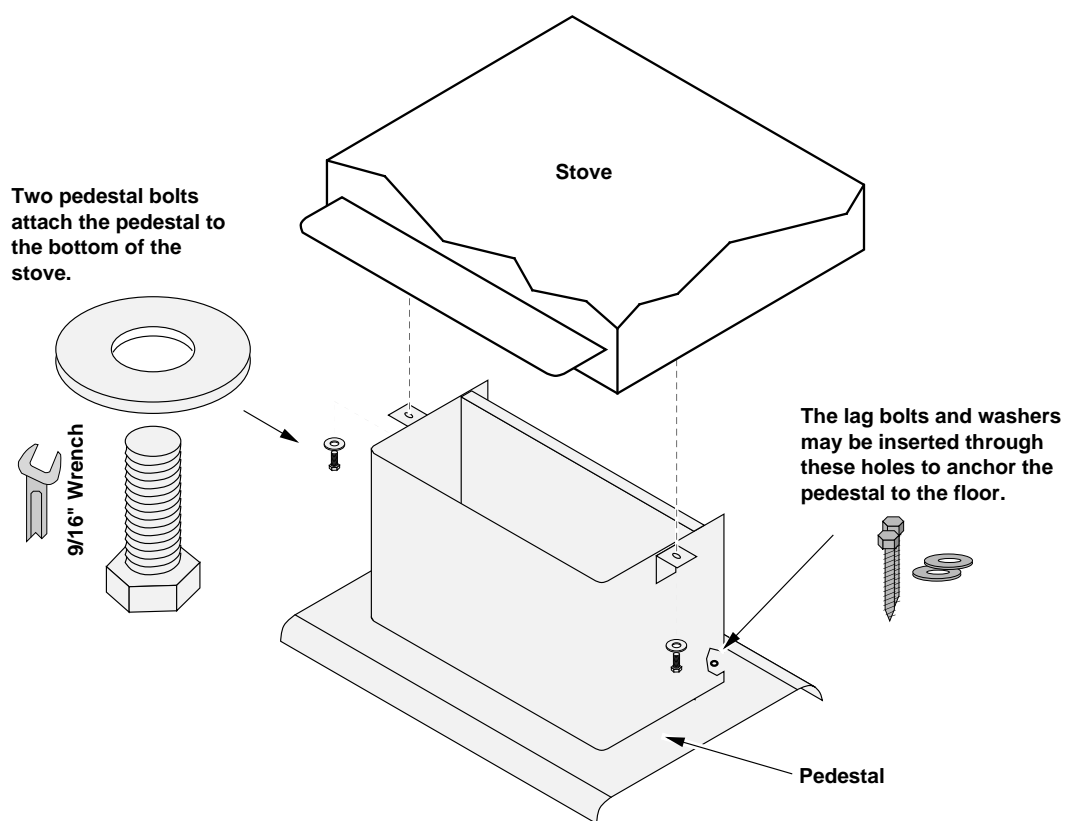

New Small Pedestals Example Shown - Lopi

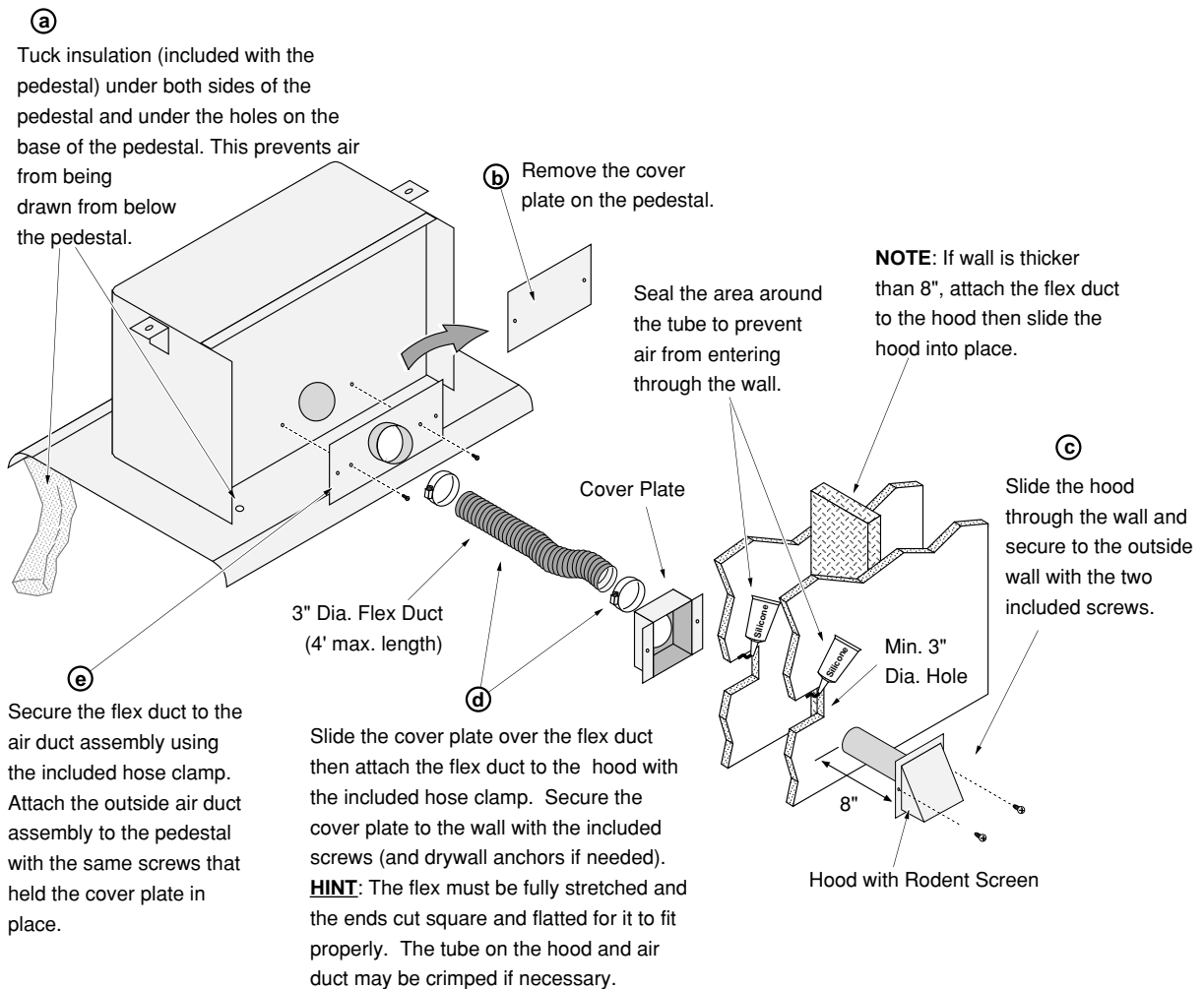

Remove the two screws on the cover plate to remove the piece that fits over the air control rod. Then replace the piece when the cover plate is in place.

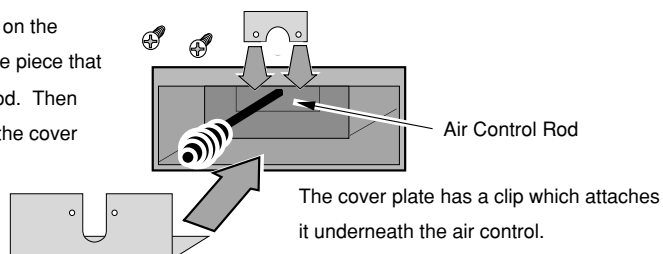

New Small Pedestals Example Shown - Lopi

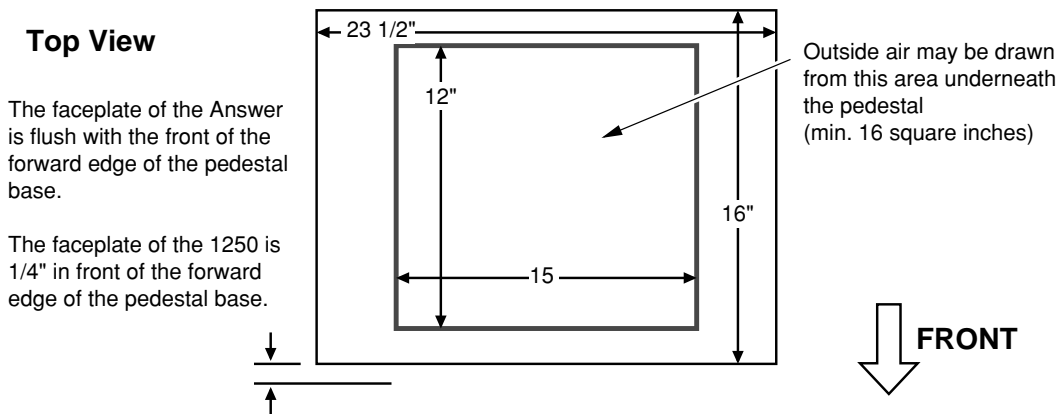

Remove the two screws on the cover plate to remove the piece that fits over the air control rod. Then replace the piece when the cover plate is in place.

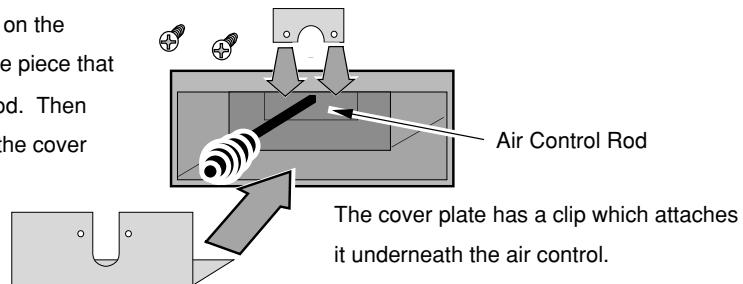

Insulation is used to seal the side edges of the pedestal .

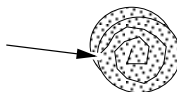

Screen is used to prevent rodents from entering.

Staples are used to attach the screen to the floor.

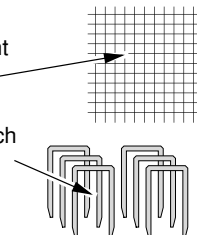

New Large Pedestals Example Shown - Avalon

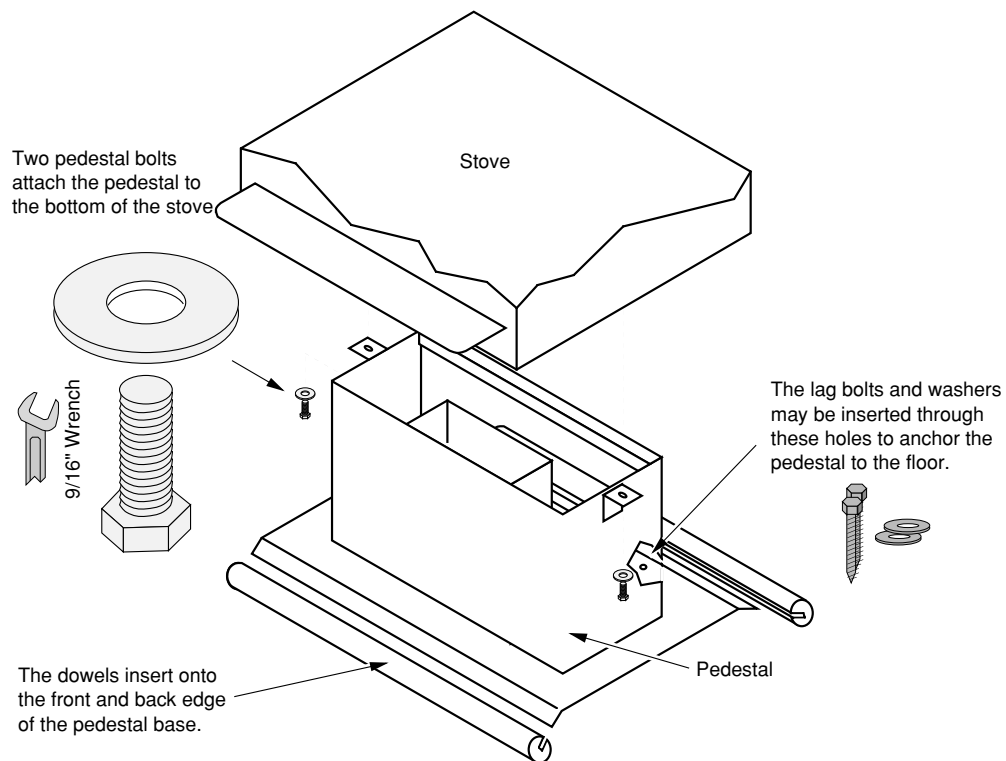

New Large Pedestals

Example Shown - Avalon

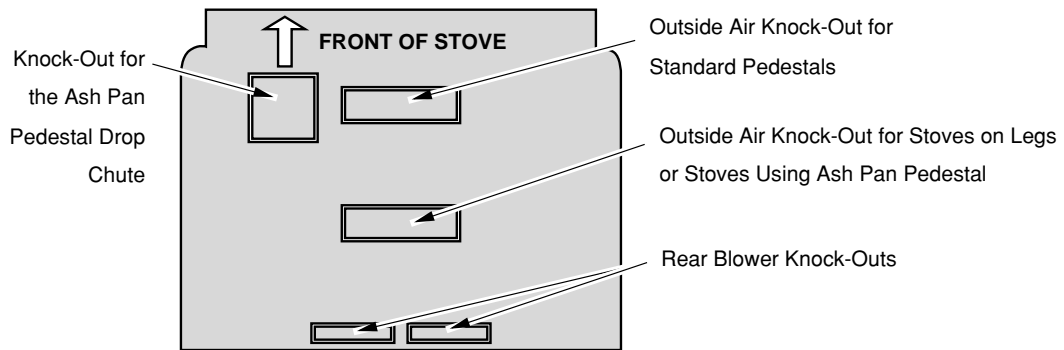

Remove the two screws on the cover plate to remove the piece that fits over the air control rod. Then replace the piece when the cover plate is in place.

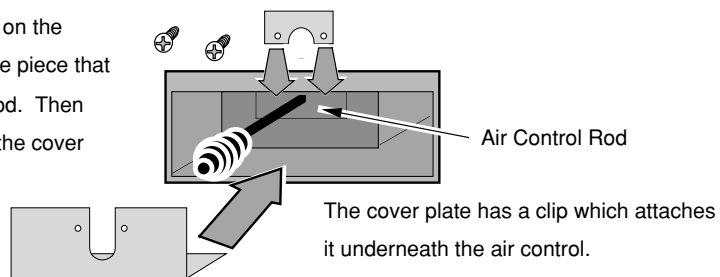

New Large Pedestals Example Shown - Avalon

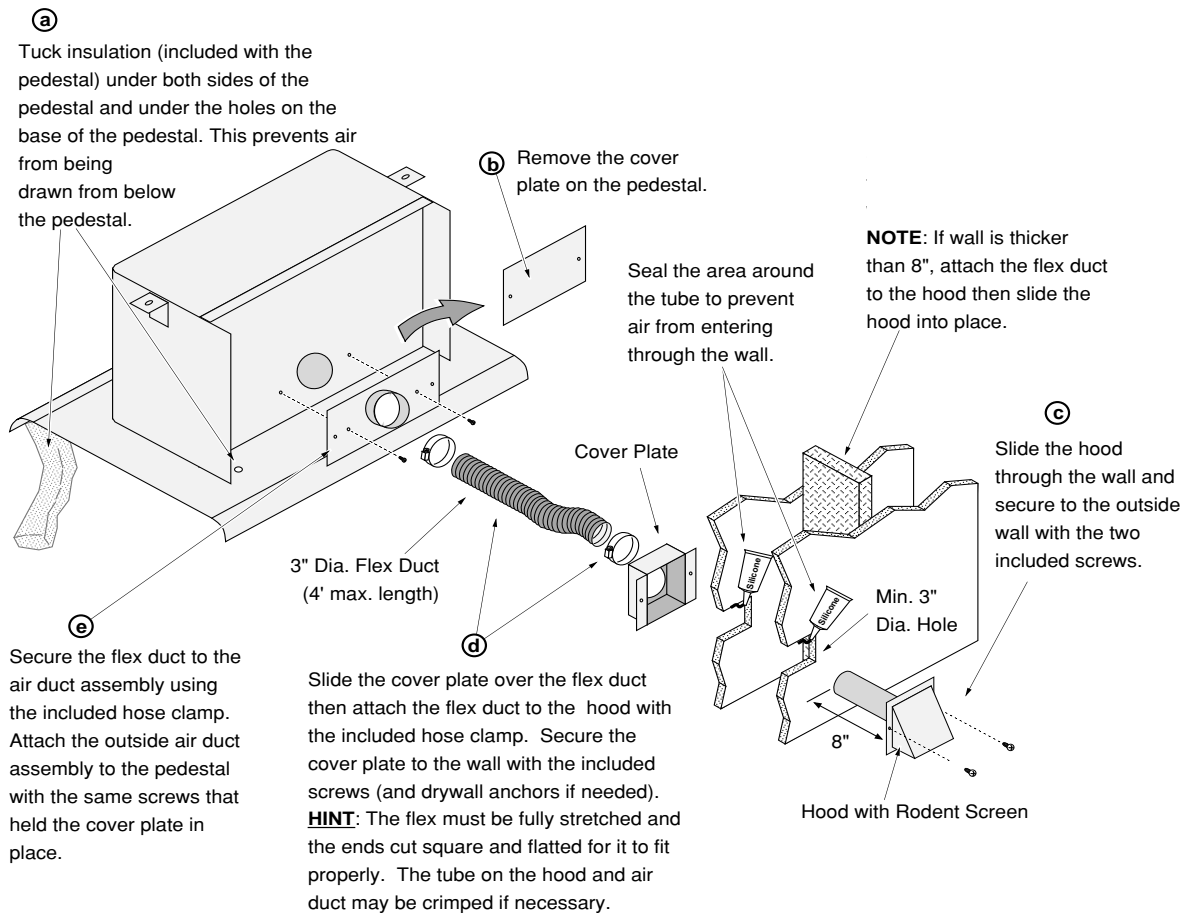

New Large Pedestals Example Shown - Avalon

Top View

The faceplate of the Rainier (45/90) is 1-1/2" behind the forward edge of the pedestal base.

The faceplate of the Olympic is 1/4" in front of the forward edge of the pedestal base.

The faceplate of the 1750 is 2-1/2" in front of the forward edge of the pedestal base.

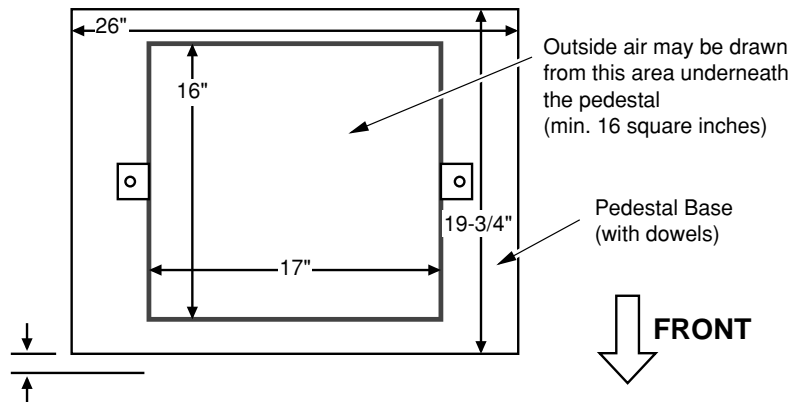

Insulation is used to seal the side edges of the pedestal.

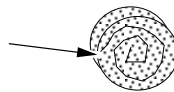

Screen is used to prevent rodents from entering.

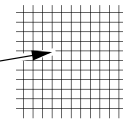

Staples are used to attach the screen to the floor.

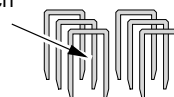

Pedestal - Avalon Ashpan

Avalon Ashpan Installation Instructions

Part # 99200125

CHECK CONDITION OF SHIPMENT

Upon receipt of this kit, check the condition of the packaging. Damage to the package should be noted on the carrier's freight receipt. Any damage claims as a result of shipping must be handled through the shipper. Travis Industries will provide assistance in resolving shipping claims or replacing items not included in the package. Please report any missing items immediately.

COMPATIBILITY

Avalon Rainier-90's (990) with Serial Number 4076 or Larger
Avalon Olympics (1190) with Serial Number 9760 or Larger

TOOLS REQUIRED

- Large Screwdriver
- 9/16" Wrench
- 7/16" Wrench

PACKING LIST

- Pedestal
- Ashpan
- Four 3/8"x3/4" Bolts & Washers
- Four Bricks (only two are used - see the instructions below)
- Drop Chute
- Stove Gasket Cement
- Two Dowels
- Two Lag Bolts, Washers
- Drop Chute Gasket
- Outside Air Equipment (Rodent Screen, Staples, Cover Plate, Insulation)

INSTALLATION INSTRUCTIONS

? If using outside air, see "Outside Air Installation" on page 4 & 5 of these instructions.

- 1 Place the pedestal into position on the floor protection. Lift the pedestal up and insert the two dowels included with this kit onto the forward and rear edge of the pedestal base. Lift the stove onto the pedestal base (with the ashpan removed). Line up the press-nuts on the bottom of the stove with the two attachment brackets on the pedestal. Insert the four bolts, with washers, through the brackets on the pedestal and into the stove. Tighten the bolts with a 9/16" wrench.

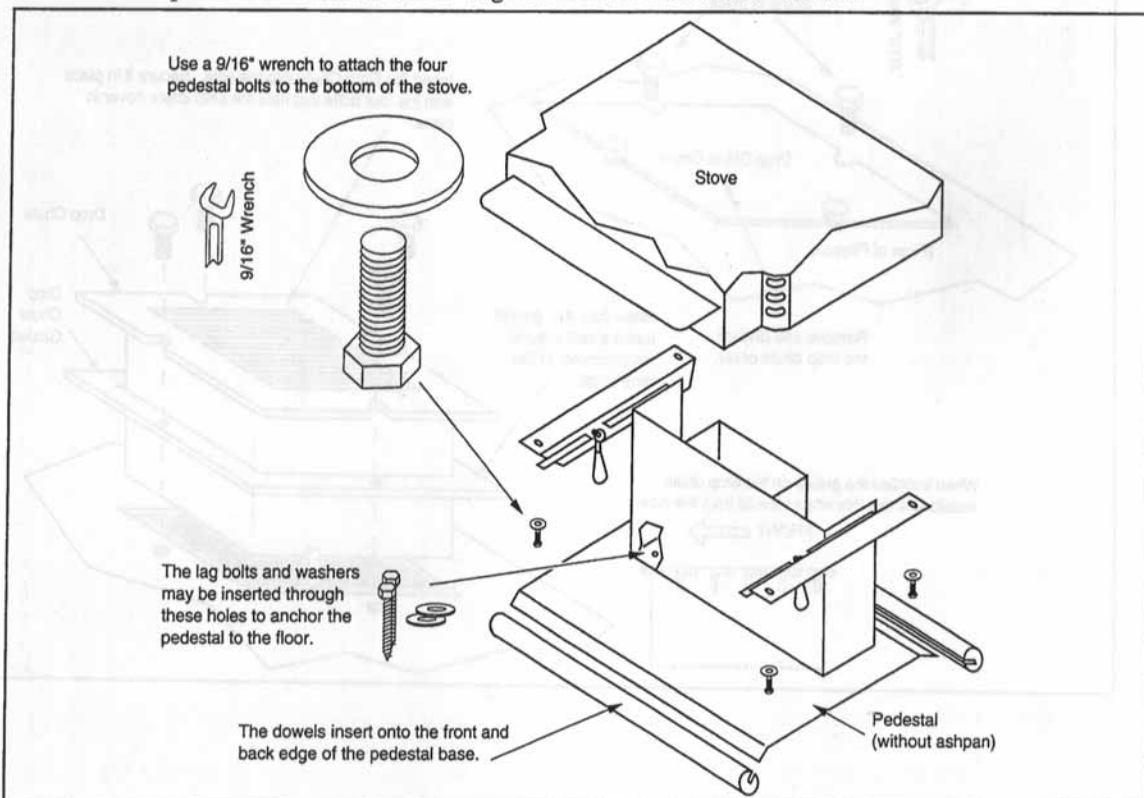

Mantle Shield

Mantel Shield

#99100100

CHECK CONDITION OF SHIPMENT

Upon receipt of this kit, check the condition of the packaging. Damage to the package should be noted on the carrier's freight receipt. Any damage claims as a result of shipping must be handled through the shipper. Travis Industries will provide assistance in resolving shipping claims or replacing items not included in the package. Please report any missing items immediately.

COMPATIBILITY

• Lopi Revere • Avalon 745/790 • Avalon 945/990 • Avalon 1190

PACKING LIST

• Mantel Shield • Instruction Sheet

INSTALLATION INSTRUCTIONS

The mantel shield may be used with the fireplace inserts listed above to reduce the mantel clearance. Follow the clearances listed in the owner's manual.

1. Slide the mantel shield between the top surround panel and facing (see the illustration below). Gravity will hold it in place.

Center the mantel shield over the insert and slide it behind the surround panel.

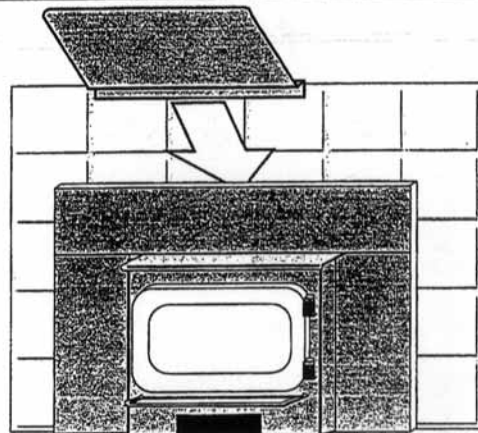

When in place it will look like this.

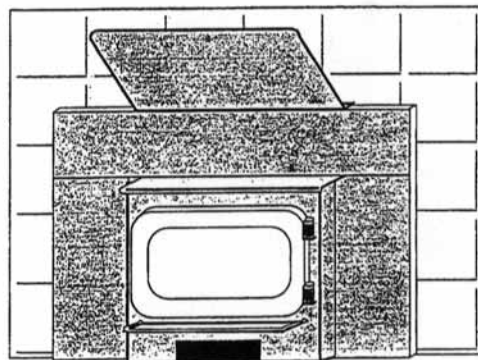

Etched Glass

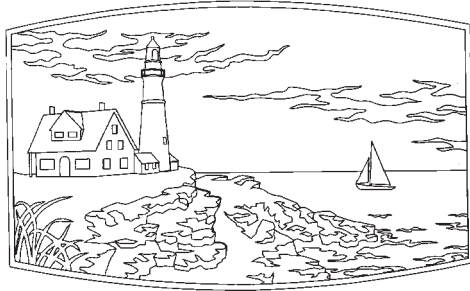

LIGHTHOUSE

Avalon Etched Glass Large & Small Sizes

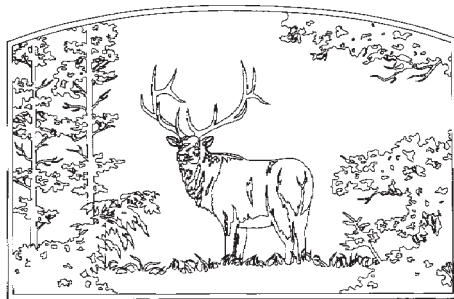

ELK

LOPI Etched Glass Large & Small Sizes

Fire Screens

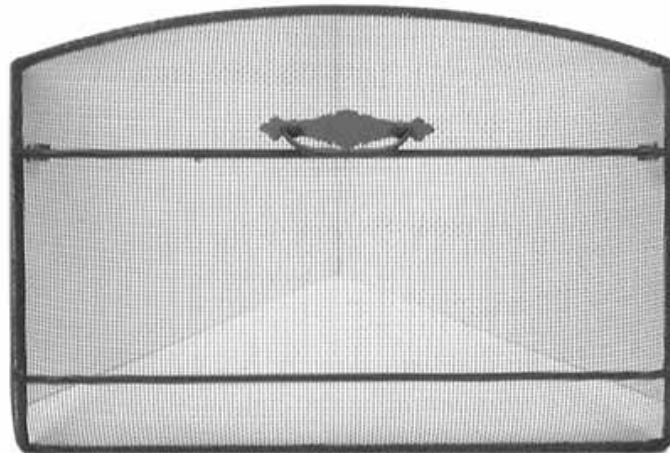

**For LOPI
in Large & Small Sizes**

**For Avalon
in Large Only**

Panels

Panel Set, Avalon

CHECK CONDITION OF SHIPMENT

Upon receipt of this kit, check the condition of the packaging. Damage to the package should be noted on the carrier's freight receipt. Any damage claims as a result of shipping must be handled through the shipper. Travis Industries will provide assistance in resolving shipping claims or replacing items not included in the package. Please report any missing items immediately.

COMPATIBILITY

- Avalon Pendleton
- Avalon Rainier
- Avalon Olympic

ITEMS NEEDED FOR ASSEMBLY

- 5/16" and 3/8" Nutdriver
- Small & Large Standard Screwdriver
- Drill with 11/64" Bit

PACKING LIST

- Top Panel
- Two Side Panels
- Trim (& hardware)
- Insulation
- (4) 10-24 Type F Thread-Cutting Screws
- 7 Spring Clips

PANEL SIZING and PART NUMBERS

Model	Size	Size Installed (including trim)	Black Trim
Pendleton (745/790)	8"	39 7/8" wide by 28" high	99300300
Pendleton (745/790)	10"	43 7/8" wide by 30" high	99300301
Pendleton (745/790)	12"	47 7/8" wide by 32" high	99300302
Rainier (945/990)	8"	41 3/4" wide by 28 7/8" high	99300306
Rainier (945/990)	10"	45 3/4" wide by 30 7/8" high	99300307
Rainier (945/990)	12"	49 3/4" wide by 32 7/8" high	99300308
Olympic (1190)	8"	45 1/4" wide by 28 7/8" high	99300312
Olympic (1190)	10"	49 1/4" wide by 30 7/8" high	99300313
Olympic (1190)	12"	53 1/4" wide by 32 7/8" high	99300314

INSTALLATION INSTRUCTIONS

1. With the insert 12" from the fireplace, install the side surround panels (see the directions below).

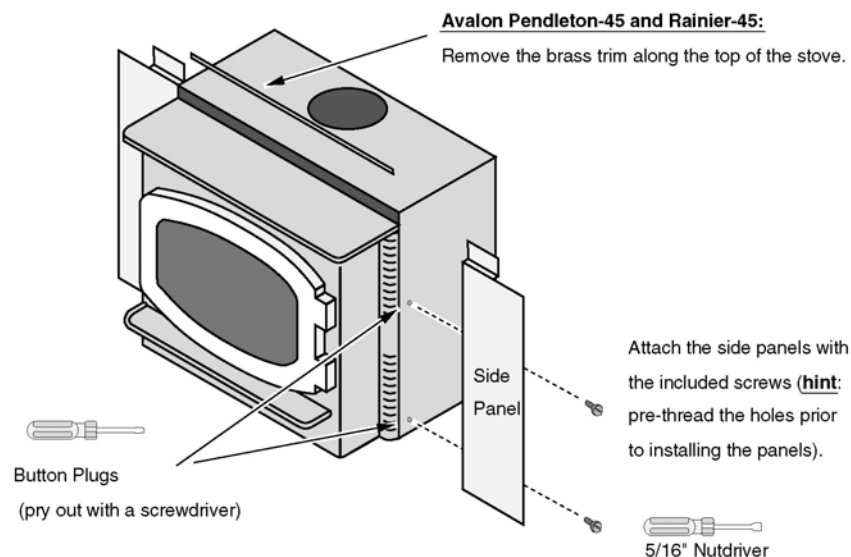

Panels

Panel Set, Avalon

- Adjust the position of the side panels so they are: 1) flush with the bottom of the insert; 2) both the same distance back from the front of the insert; 3) perpendicular to the floor (use the top panel, if necessary, to judge alignment). Tighten the screws that hold the side panels in place.
- Place the insert into the fireplace and connect the flue (if using a positive or direct connection). Install the top panel and trim following the directions below.

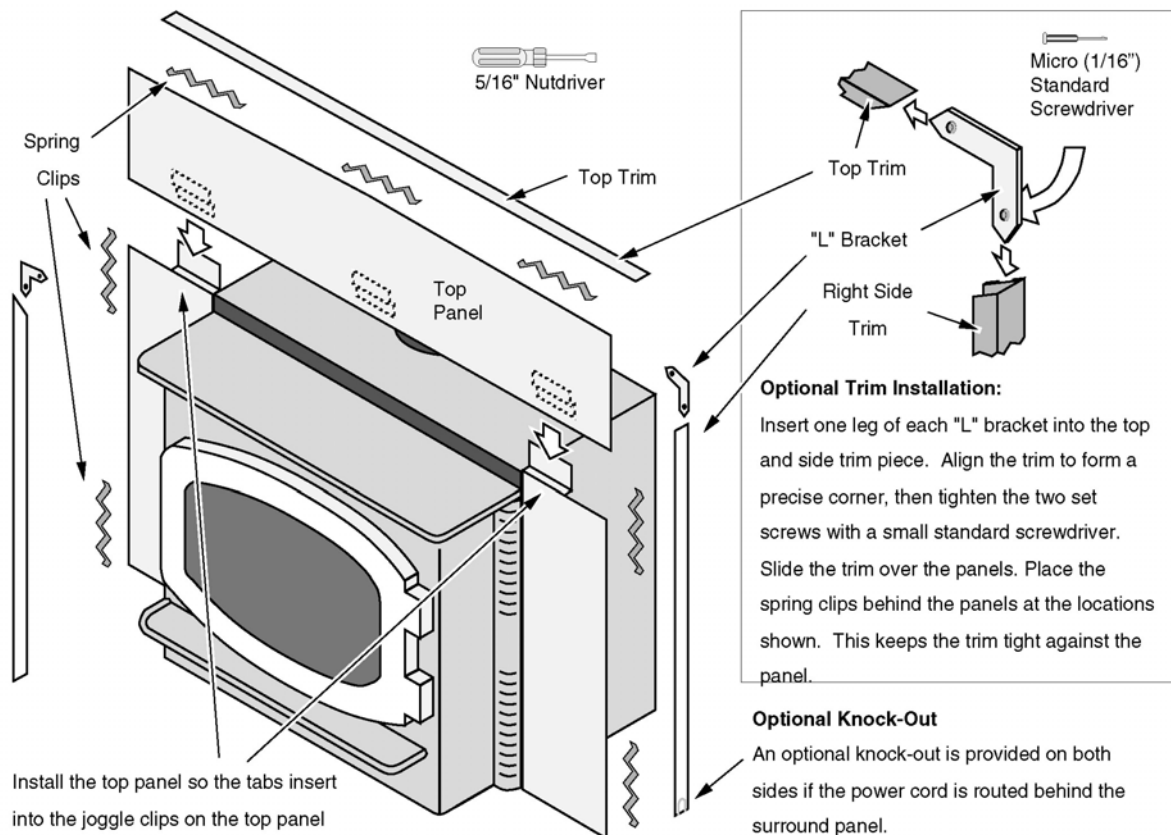

Insulation Installation (required only for face seal installations)

- With the insert drawn 6" from the fireplace, glue the insulation strip included with the insert to the back of the panels using RTV silicon or stove gasket cement. The insulation should be installed so it overlaps the fireplace opening to form a seal between the panels and the fireplace face. Let the silicon or cement dry.
- Push the insert into the fireplace, allowing the insulation to form a seal between the panels and the fireplace. Use a screwdriver to tuck any exposed insulation behind the panels.

Panels

Panel Set, Answer - 2003

(see part #'s below)

CHECK CONDITION OF SHIPMENT

Upon receipt of this kit, check the condition of the packaging. Damage to the package should be noted on the carrier's freight receipt. Any damage claims as a result of shipping must be handled through the shipper. Travis Industries will provide assistance in resolving shipping claims or replacing items not included in the package. Please report any missing items immediately.

COMPATIBILITY

- Lopi Answer

ITEMS NEEDED FOR ASSEMBLY

- 5/16" Nutdriver
- Small & Large Standard Screwdriver

PACKING LIST

- Top and Side Panels
- Four 10-24 Self-Threading Screws
- Insulation
- Trim (with hardware)
- Two Leveling Bolts – for leveling the stove in the fireplace
- (7) Spring Clips

PANEL SIZING and PART NUMBERS

Surround Panel Size	Size (Including Trim)	Black Trim #
8"	40 1/8" width by 28 1/4" height	99300285
10"	44 1/8" width by 30 1/4" height	99300286

INSTALLATION INSTRUCTIONS

1. With the insert 12" from the fireplace, install the side surround panels (see the directions below)

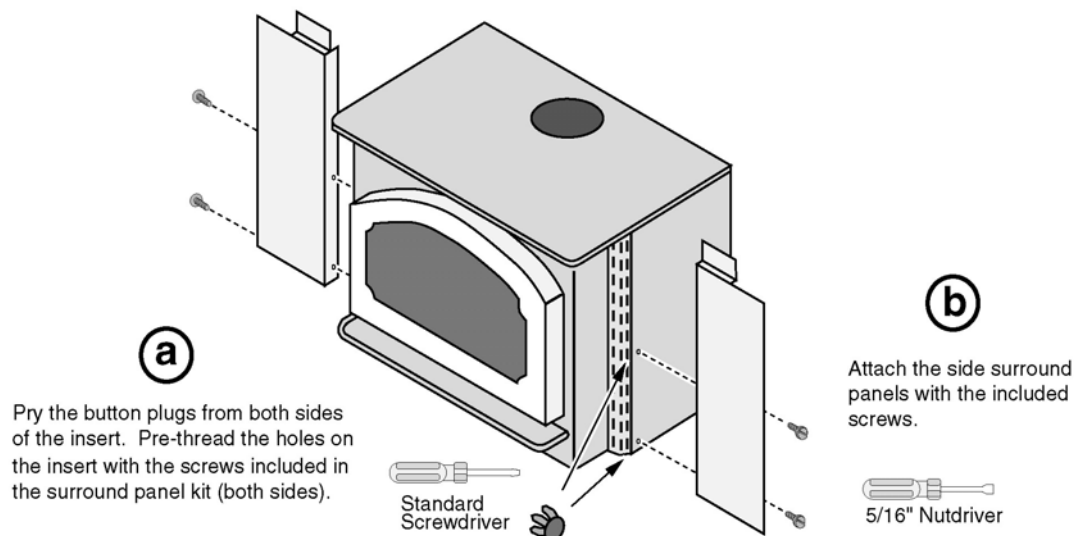

Panels

Panel Set, Answer - 2003

(see part #'s below)

- Adjust the position of the side panels so they are: 1) aligned with the top of the insert; 2) both the same distance back from the front of the insert; 3) perpendicular to the floor (use the top panel, if necessary, to judge alignment). Tighten the screws that hold the side panels in place.
- Place the insert into the fireplace and connect the flue (if using a positive or direct connection). Install the top panel and trim following the directions below.

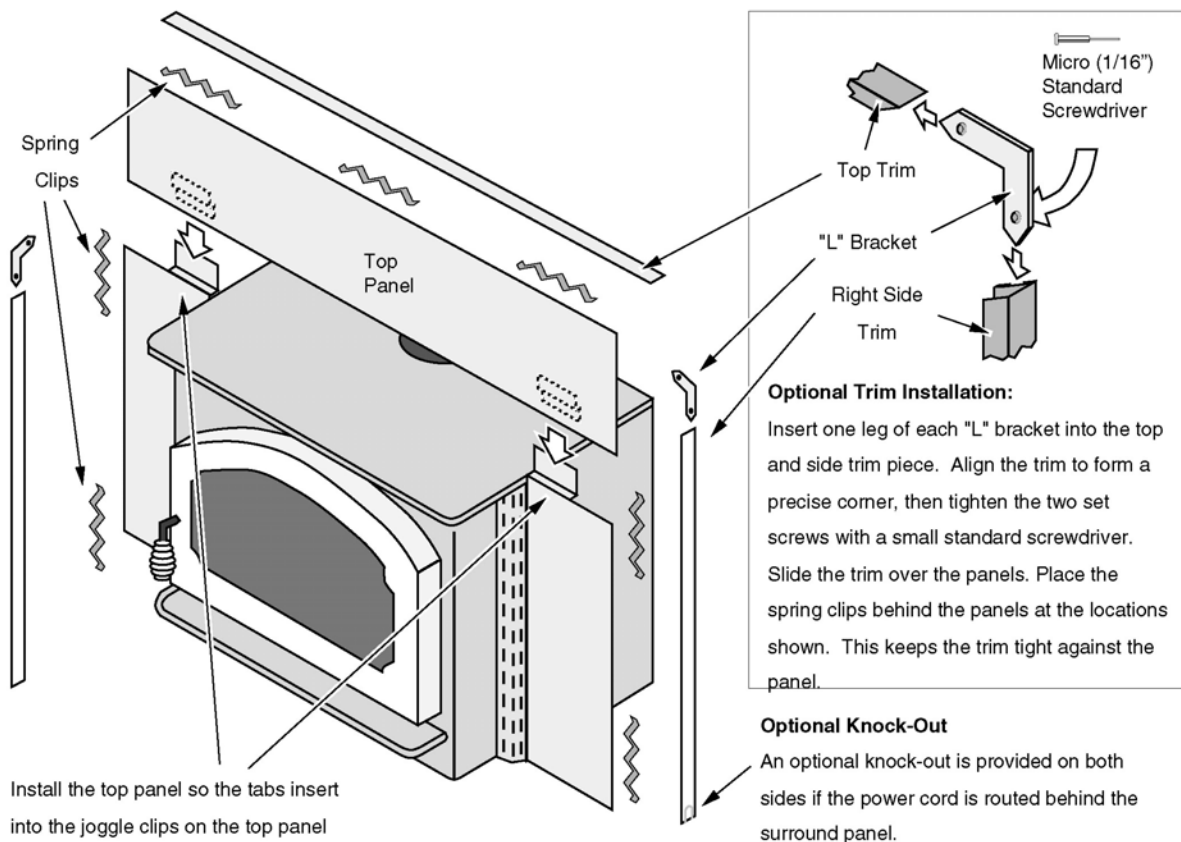

Insulation Installation (required only for face seal installations)

- With the insert drawn 6" from the fireplace, glue the insulation strip included with the surround panel kit to the back of the panels using RTV silicon or stove gasket cement. The insulation should be installed so it overlaps the fireplace opening to form a seal between the panels and the fireplace face. Let the silicon or cement dry.
- Push the insert into the fireplace, allowing the insulation to form a seal between the panels and the fireplace. Use a screwdriver to tuck any exposed insulation behind the panels.

Panels

Panel Set, Revere - 2003 (see part #'s below)

CHECK CONDITION OF SHIPMENT

Upon receipt of this kit, check the condition of the packaging. Damage to the package should be noted on the carrier's freight receipt. Any damage claims as a result of shipping must be handled through the shipper. Travis Industries will provide assistance in resolving shipping claims or replacing items not included in the package. Please report any missing items immediately.

COMPATIBILITY

- Lopi Revere •Lopi Spirit Bay •Lopi Heritage Bay Insert

ITEMS NEEDED FOR ASSEMBLY

- 5/16" and 3/8" Nutdriver • Small & Large Standard Screwdriver

PACKING LIST

- Top Panel • Two Side Panels (7) Spring Clips • Trim (& hardware)

PANEL SIZING and PART NUMBERS

Size	Height	Width	Black Trim #
8"	27 5/8"	40 3/8 "	99300289
10"	29 5/8"	44 3/8 "	99300290
12"	31 5/8"	48 3/8 "	99300291

INSTALLATION INSTRUCTIONS

1. With the insert 12" from the fireplace, install the side surround panels (see the directions below).

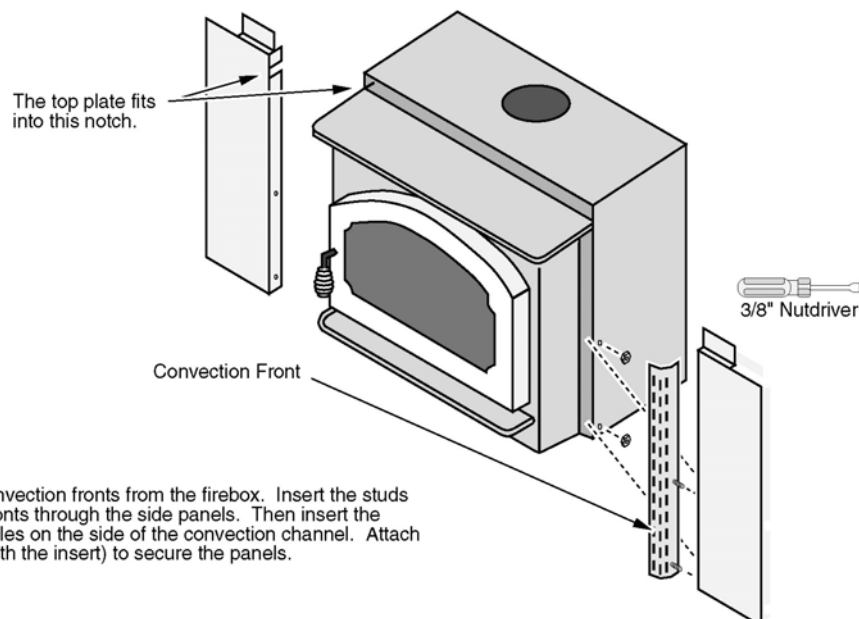

Remove the side convection fronts from the firebox. Insert the studs on the convection fronts through the side panels. Then insert the studs through the holes on the side of the convection channel. Attach the nuts (included with the insert) to secure the panels.

Panels

Panel Set, Revere - 2003 (see part #'s below)

- Adjust the position of the side panels so they are: 1) flush with the bottom of the insert; 2) both the same distance back from the front of the insert; 3) perpendicular to the floor (use the top panel, if necessary, to judge alignment). Tighten the screws that hold the side panels in place.
- Place the insert into the fireplace and connect the flue (if using a positive or direct connection). Install the top panel and trim following the directions below.

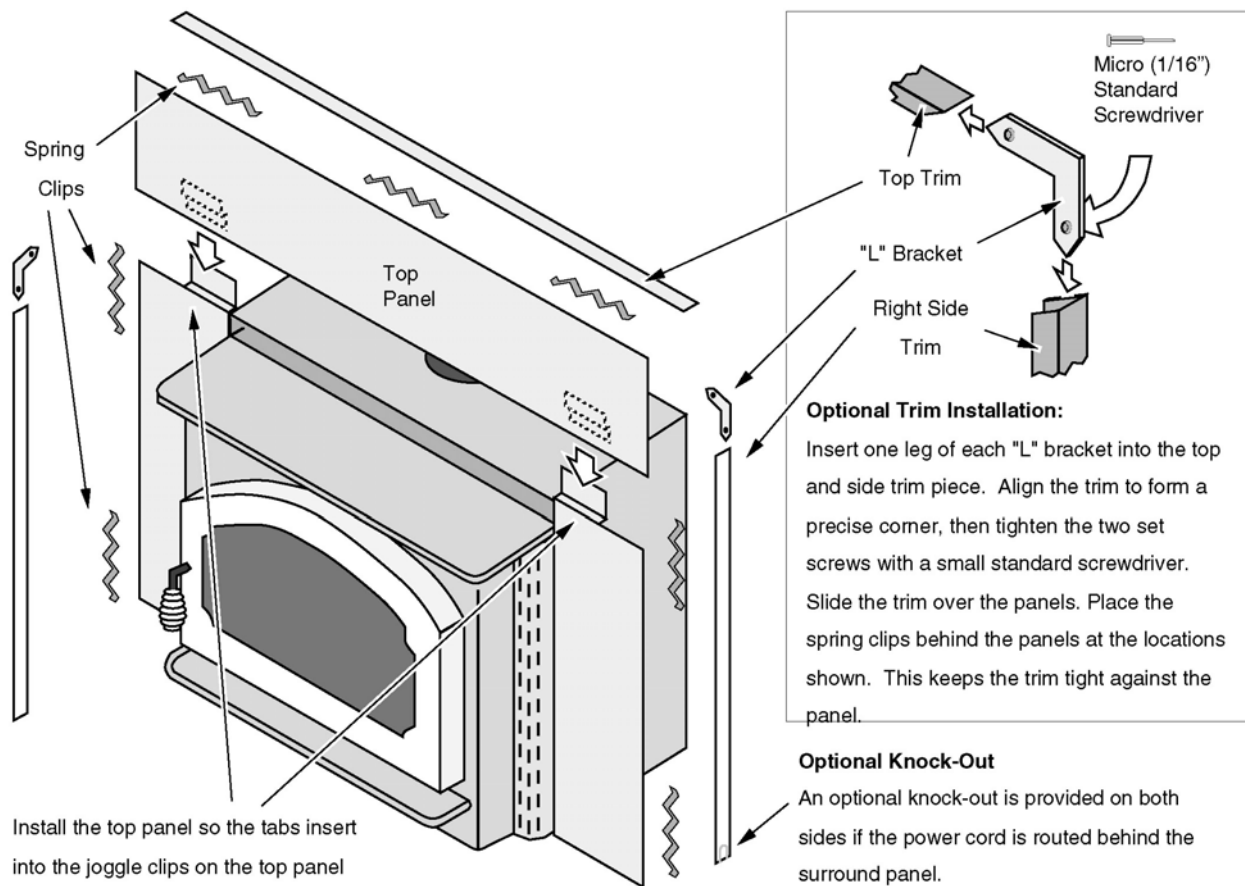

Insulation Installation (required only for face seal installations)

- With the insert drawn 6" from the fireplace, glue the insulation strip included with the insert to the back of the panels using RTV silicon or stove gasket cement. The insulation should be installed so it overlaps the fireplace opening to form a seal between the panels and the fireplace face. Let the silicon or cement dry.
- Push the insert into the fireplace, allowing the insulation to form a seal between the panels and the fireplace. Use a screwdriver to tuck any exposed insulation behind the panels.

Panels

Panel Set, Freedom & Freedom Bay - 2003 (see part #'s below)

CHECK CONDITION OF SHIPMENT

Upon receipt of this kit, check the condition of the packaging. Damage to the package should be noted on the carrier's freight receipt. Any damage claims as a result of shipping must be handled through the shipper. Travis Industries will provide assistance in resolving shipping claims or replacing items not included in the package. Please report any missing items immediately.

COMPATIBILITY

- Lopi Freedom
- Lopi Freedom Bay

ITEMS NEEDED FOR ASSEMBLY

- 5/16" and 3/8" Nutdriver
- Small & Large Standard Screwdriver

PACKING LIST

- Top & Side Panels
- Trim (& hardware)
- (7) Spring Clips

NOTE: Mounting Hardware is included with the insert.

PANEL SIZING

Surround Panel Size	Height	Width	Black Trim #
8"	29 1/2"	45 3/8"	99300293
10"	31 1/2"	49 3/8"	99300294
12"	33 1/2"	53 3/8"	99300295

Arched Panels (Part # 99300296)

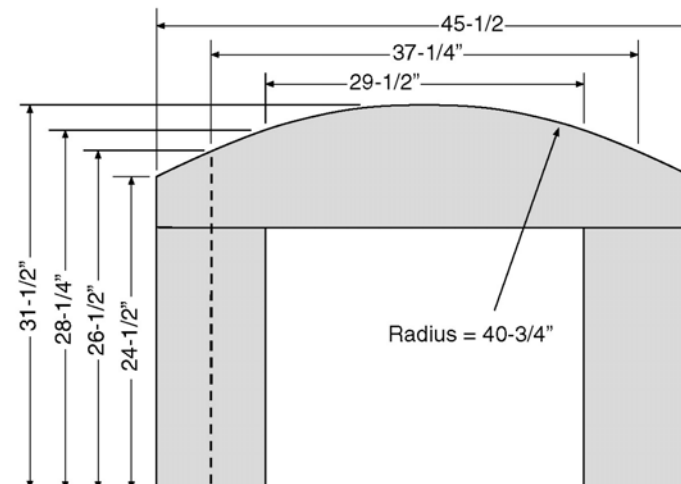

Panels

Panel Set, Freedom & Freedom Bay - 2003 (see part #'s below)

INSTALLATION INSTRUCTIONS

1. Position the insert approximately 12" from the fireplace.
2. Install the side surround panels (see the directions below).

Freedom

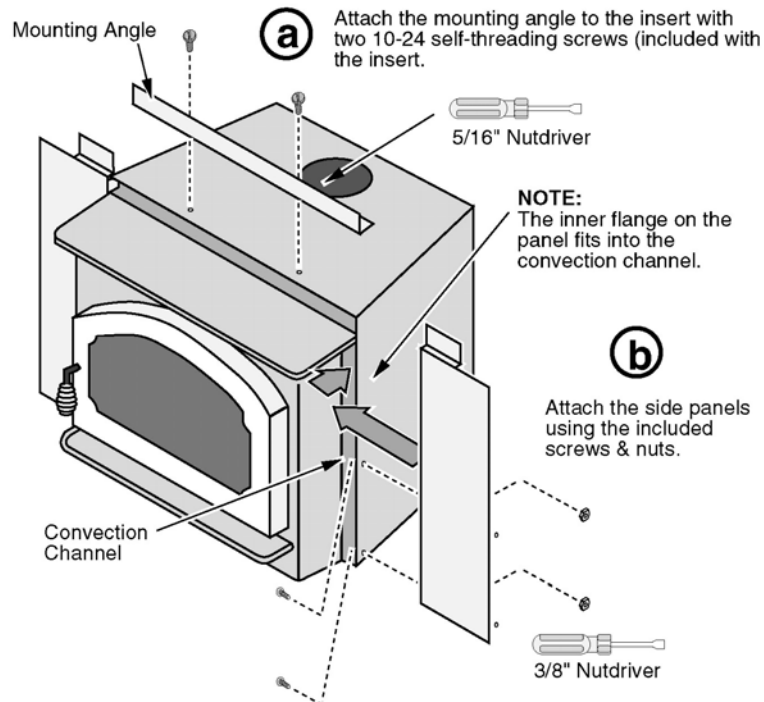

Freedom Bay

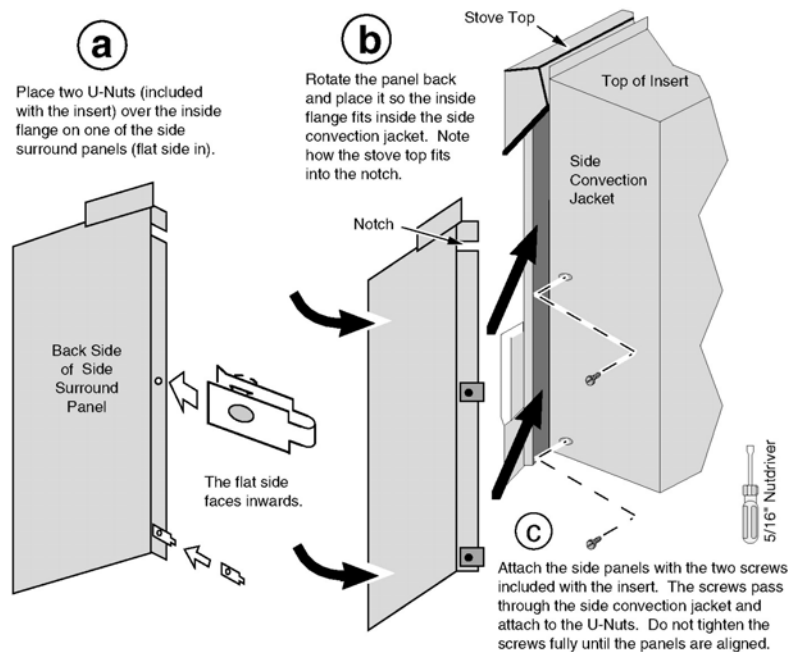

Panels

Panel Set, Freedom & Freedom Bay - 2003 (see part #'s below)

- Adjust the position of the side panels so they are: 1) flush with the bottom of the insert; 2) both the same distance back from the front of the insert; 3) perpendicular to the floor (use the top panel, if necessary, to judge alignment. The Freedom may require slight adjustment of the mounting angle. Tighten the screws that hold the side panels in place.
- Place the insert into the fireplace and connect the flue (if using a positive or direct connection). Install the top panel and trim following the directions below.

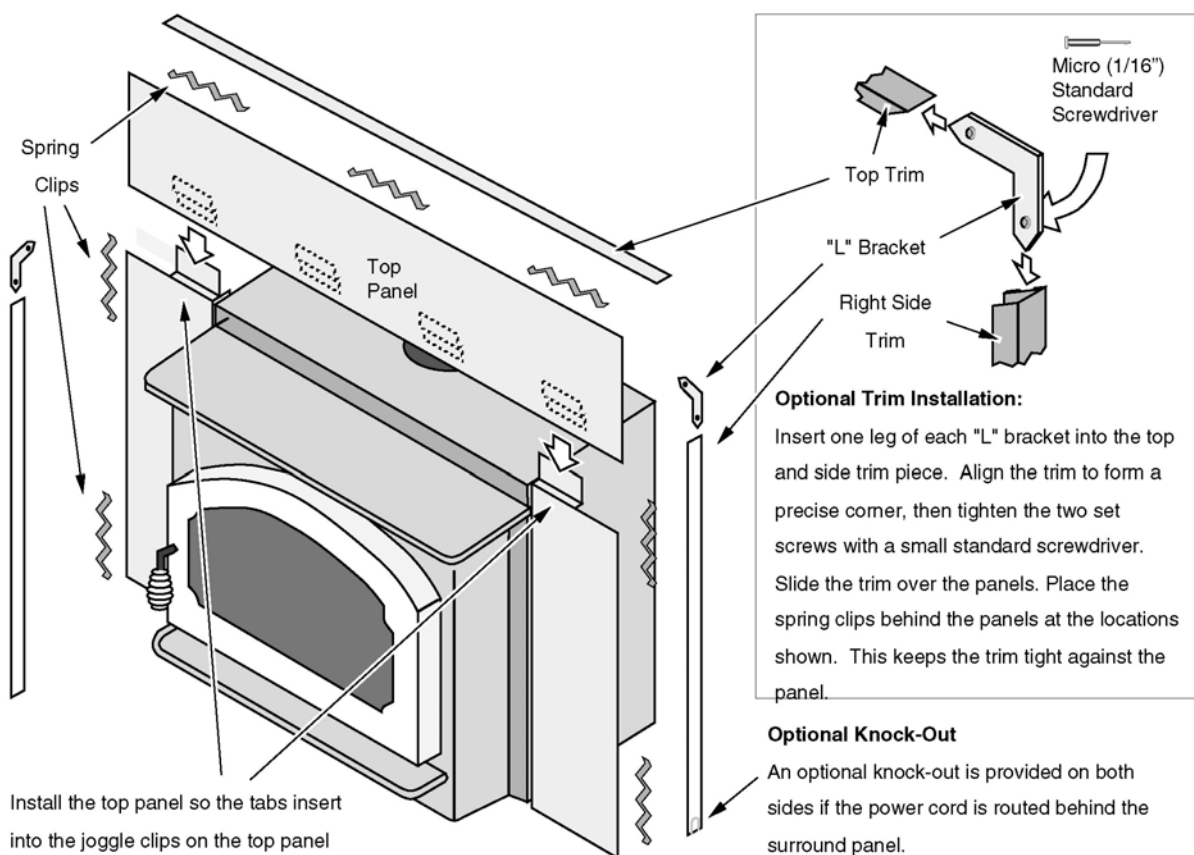

Insulation Installation (required only for face seal installations)

- With the insert drawn 6" from the fireplace, glue the insulation strip included with the surround panel kit to the back of the panels using RTV silicon or stove gasket cement. The insulation should be installed so it overlaps the fireplace opening to form a seal between the panels and the fireplace face. Let the silicon or cement dry.
- Push the insert into the fireplace, allowing the insulation to form a seal between the panels and the fireplace. Use a screwdriver to tuck any exposed insulation behind the panels.

Wood Appliance Maintenance

WEEKLY	BI-MONTHLY	YEARLY
<ul style="list-style-type: none"> • Remove ash • Clean glass • Clean brass • Check for creosote build-up in the connector and chimney 	<ul style="list-style-type: none"> • Door, door gasket, and glass gasket inspection • Lubricate door hinge with high temperature lubricant 	<ul style="list-style-type: none"> • Check and clean chimney connector, chimney and cap • Check <ul style="list-style-type: none"> - Baffle refractory - Baffle supports - Secondary air tubes - Secondary air tube collars - Floor and wall firebrick - Bypass assembly • Pull and clean the blower • Clean and touch-up paint the stove • Lubricate the air slide with high temperature lubricant

MAINTENANCE SCHEDULE

Your appliance requires periodic maintenance to work correctly. The steps involved with maintenance are usually quick and easy. Look through this maintenance schedule and plan accordingly.

WARNING: Failure to properly maintain and inspect your appliance may reduce the performance and life of the appliance, void your warranty, and create a fire hazard.

PERIODIC MAINTENANCE (every week when appliance is in use):

- Remove ash from the firebox (if necessary)
- Clean the viewing glass (if necessary)
- Clean the brass (if necessary)
- Check for creosote buildup in the chimney and connector

BI-MONTHLY MAINTENANCE (every two months during the heating season):

- Door and glass inspection
- Lubricate the door hinge

YEARLY MAINTENANCE (before every heating season):

- Touch-up paint
- Blower cleaning
- Firebrick and baffle inspection and cleaning

REMOVE ASH FROM THE FIREBOX (IF NECESSARY)

At least once a week while the appliance is in use, check the level of ash on the floor of the firebox. If 1" or more of ash has accumulated, let the appliance cool and place the excess ash into an airtight container away from any structure. After the ash is fully extinguished it may be disposed. A 1/2" to 1" bed of ash is desirable, for it allows the appliance to burn at a slightly lower speed.

WARNING: Ashes removed from the appliance must be stored in an airtight container away from any structure until fully extinguished before disposing.

CLEAN THE VIEWING GLASS (IF NECESSARY)

This appliance has an airwash to keep the glass clean. However, burning un-seasoned wood or burning on lower burn rates leads to dirtier glass (especially on the sides). Clean the glass by following the directions below. For especially dirty glass, use fine steel wool to remove build-up.

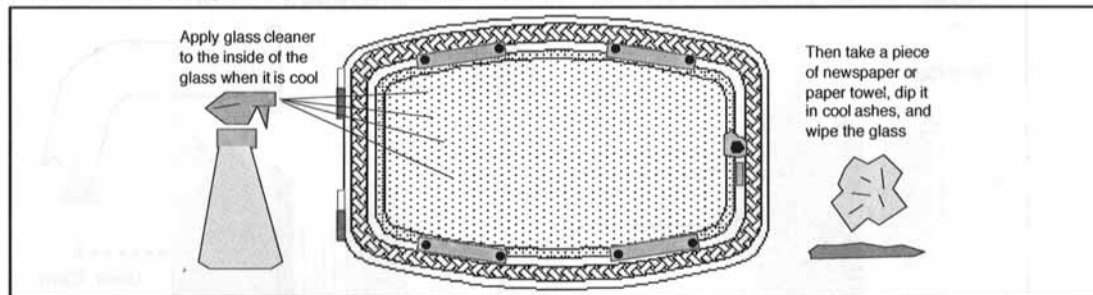

CLEAN THE BRASS (IF NECESSARY)

If your unit has a brass door, it may be cleaned using a non-abrasive polish (such as FLITZ®) when the appliance is cool. The brass trim and ashlip is anodized, and should be cleaned with soap and water.

CHECK FOR CREOSOTE BUILDUP

Creosote buildup should be checked twice monthly during the heating season. Either look down the chimney from the top or remove a chimney connector section. Any more than 1/4" of buildup requires chimney cleaning. Creosote develops quickest when burning at a low temperature or when burning un-seasoned wood. When wood is burned slowly, it produces tar and other vapors which combine with moisture to form creosote. Creosote vapors condense in the relatively cool chimney flue and creosote residue accumulates on the flue lining. When ignited, this creosote makes an extremely hot fire.

Replacing the Door Gasket

Remove the door by opening it and lifting it off the hinges. Remove the old gasket by stripping it away with a screwdriver or other tool (see the illustration below). Apply a line of gasket cement (available from your dealer) in the groove that follows the perimeter of the door. Insert the gasket into the groove. Do not stretch the gasket as you place it into the groove. Cut off any excess gasket when done. Allow 2 hours for the cement to dry. When re-installing the door, the gasket may need to be flattened by repeatedly opening and closing the door.

Replacing the Glass or Glass Gasket

Remove the door by opening it and lifting it off the hinges. Unscrew the eight screws that hold the retaining clips in place with a 5/16" nutdriver (see the illustration above). Carefully remove the glass. Align the 3/8" white rope gasket (new or old) along the ledge that follows the perimeter of the window opening. If using a new gasket, trim off any excess. Place the glass (new or old) in place so there is a small gap between the edge of the glass and the door frame. Make sure the gasket is tucked underneath the glass so the glass does not touch the door frame. Replace the glass retaining clips with 3/8" flat gasketing attached to secure the glass in place. The gasketing is required to prevent the glass from cracking or moving when the clips are secured. Tighten the retaining clips with a 5/16" nutdriver until the gaskets start to flatten. Do not overtighten.

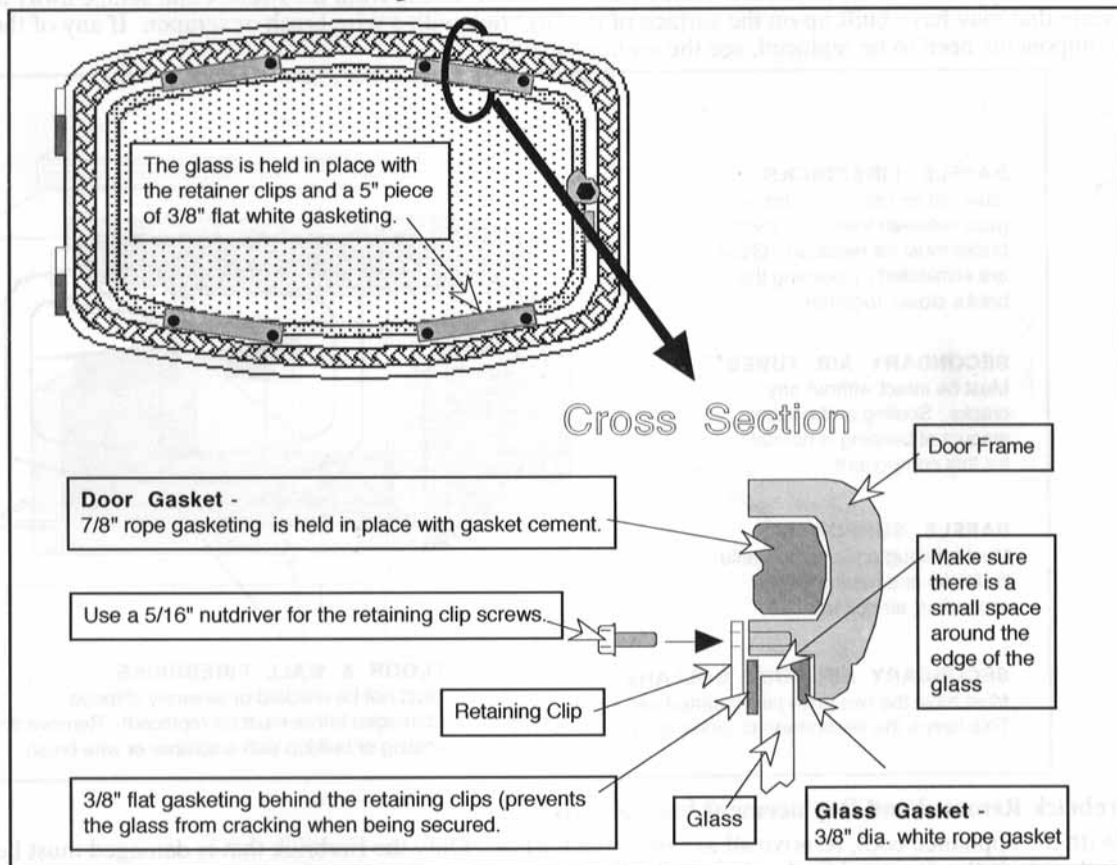

LUBRICATE THE DOOR HINGE

Periodically lubricate the door hinges with a high temperature lubricant (such as Permatex Industrial ® Anti-Seize). Lubricating the door involves removing the door by opening it and lifting it off the hinges, and placing lubricant on the hinge pins.

TRAVIS INDUSTRIES WOOD PRODUCTS



TOUCH-UP PAINT

Included with the owner's pack of this appliance is a can of Stove-Brite® paint. To touch up nicks or dulled paint, apply the paint while the appliance is cool. Use 120 grit sandpaper (clean with water and dry with a piece of cloth) if the surface requires smoothing. Wait at least one hour before starting the appliance. The touched up area will appear darker than the surrounding paint until it cures from heat. Curing will give off some fumes while curing – open windows to ventilate the fumes.

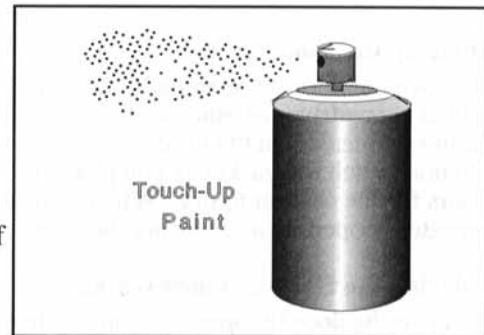

BLOWER CLEANING

The optional blower for this appliance will gather dust as it circulates air. Before cleaning, remove the blower from the appliance (instructions are included in "Optional Equipment" section in the back of this manual). Remove all dust and debris from the blower grill and around the interior of the blower.

FIREBRICK AND BAFFLE INSPECTION AND CLEANING

With the appliance cool, check the items below. Remove all ash from the firebox and scrape away any scale that may have built up on the surface of the firebrick with a wire brush or scraper. If any of the components need to be replaced, see the sections that follow.

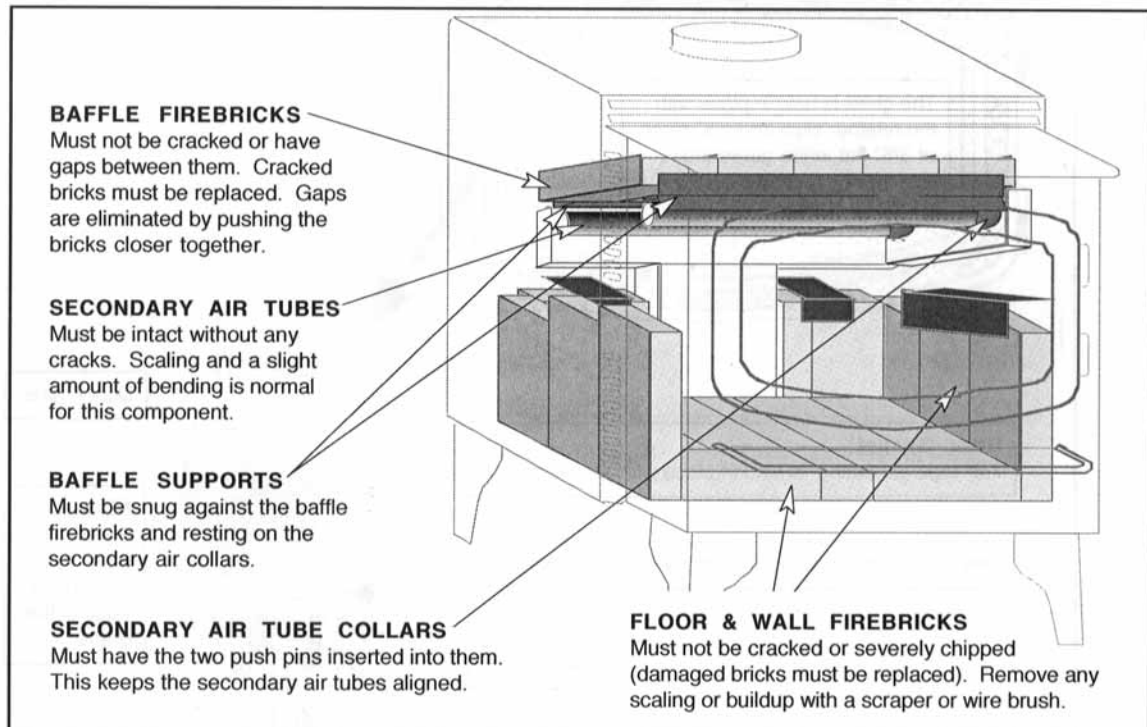

Firebrick Removal and Replacement Instructions

With the appliance cool, remove all ash from the firebox. Only the firebrick that is damaged must be replaced. If the damaged firebrick is on the floor, it can be replaced by simply removing the firebrick in front of it. **NOTE: Do not pry firebrick to remove, this will chip or crack the firebrick.** If a firebrick on the wall of the firebox needs replacement, the floor firebrick near it will need to be removed first. The wall firebrick is held upright by a clip on the walls of the firebox. To remove, pivot it out from the bottom. See the illustration on the following page.

Firebrick Removal and Replacement Instructions (Continued)

WALL FIREBRICKS
First remove the firebricks on the floor in front of the firebrick needing replacement. Then pivot it out from the bottom to clear the clip that holds it in place.

FLOOR FIREBRICKS
Remove the firebricks in front of the firebrick needing replacement.

FIREBRICK SIZES -
All firebrick is 1 1/4" x 4 1/2" x 9" except those labeled.

Firebrick labeled **(A)** are 1 1/4" x 2 1/2" x 9".

Firebrick labeled **(B)** are 1 1/4" x 1 3/8" x 9".

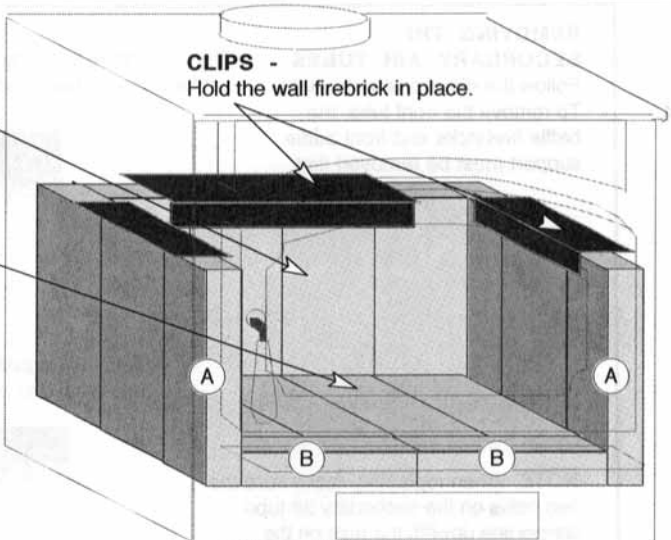

CLIPS -
Hold the wall firebrick in place.

Baffle Removal and Replacement Instructions

All of the baffle components are removable to facilitate easy cleaning and repairs. Make sure the appliance is cool before removing any of the components. The directions below detail the procedure for removing the baffle firebricks and front baffle support. See the instructions on the following page for removing the secondary air tubes.

REMOVING BAFFLE FIREBRICKS AND FRONT BAFFLE SUPPORT
Lift up on the front portion of all four firebricks. Then rotate the front baffle support forward until it can be removed. Then slide the baffle firebricks forward and out the door opening. The center bricks must be removed prior to removing the outer bricks.

NOTE:
When replacing the front baffle support, make sure it rests squarely on the secondary air tube sleeves on both ends.

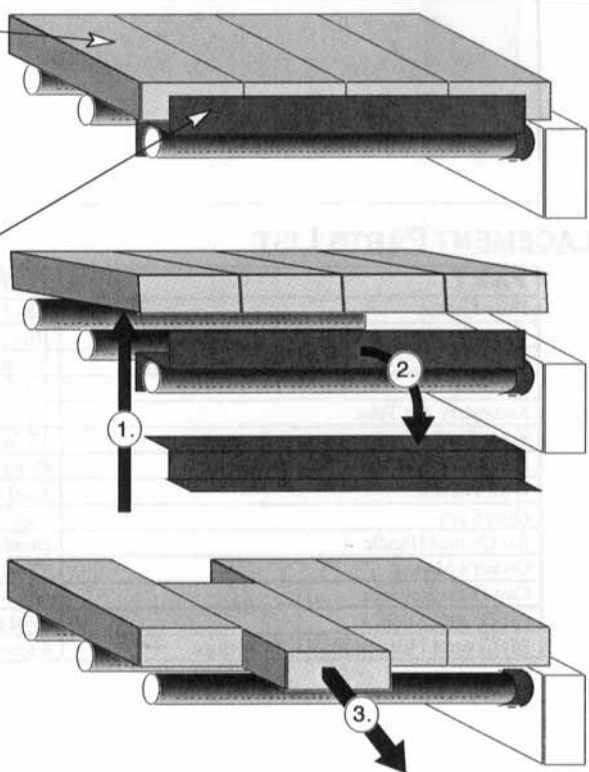

Front Baffle Support

Secondary Air Tube Sleeve

Secondary Air Tube (removal instructions are on the following page)

FIREBRICK AND BAFFLE INSPECTION AND CLEANING

With the appliance cool, remove all ash from the firebox and scrape away any scale that may have built up on the surface of the firebrick with a wire brush or scraper. Any of the firebrick on the floor or walls of the firebrick that is cracked must be replaced (see the section "Firebrick Removal and Replacement Instructions"). Next, inspect the baffle components. The illustration below details the areas that must be inspected. If any of the components need to be replaced, see the section "Baffle Removal and Replacement Instructions".

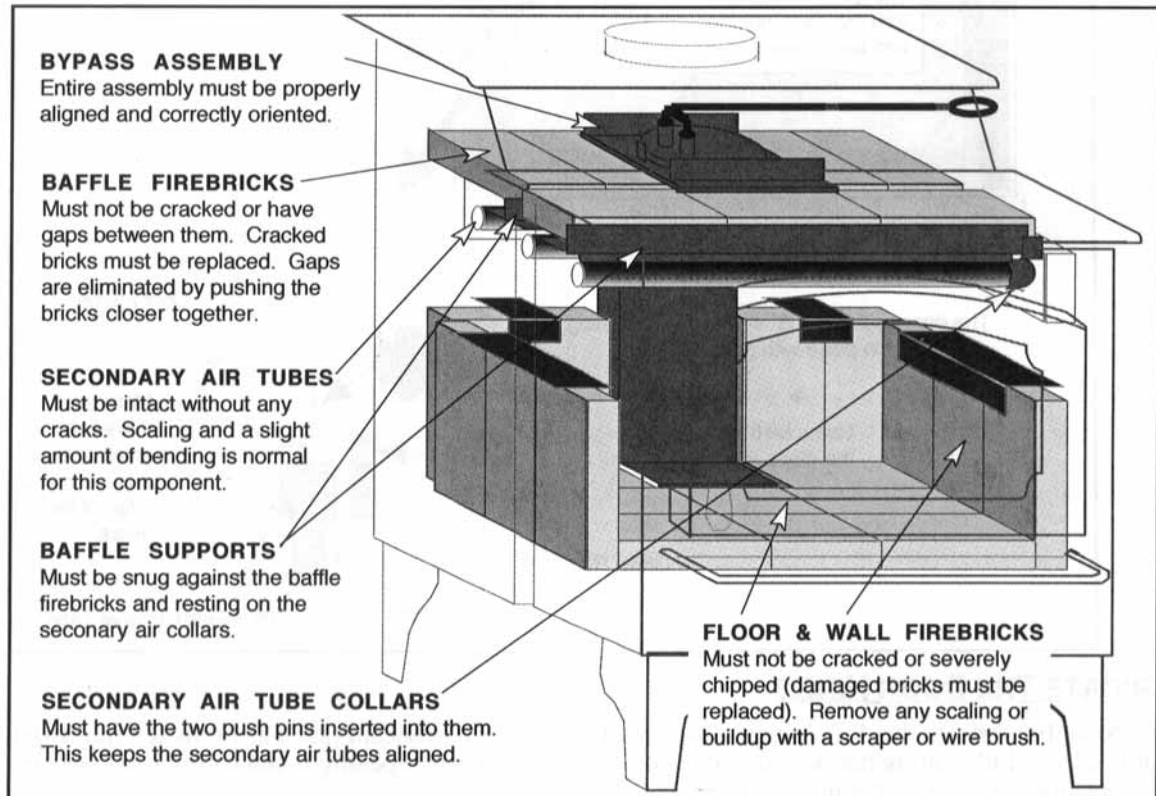

Firebrick Removal and Replacement Instructions

With the appliance cool, remove all ash from the firebox. Only the firebrick that is damaged must be replaced. If the damaged firebrick is on the floor, it can be replaced by simply removing the firebrick in front of it. **NOTE: Do not pry firebrick to remove, this will chip or crack the firebrick.** If a firebrick on the wall of the firebox needs replacement, the floor firebrick near it will need to be removed first. The wall firebrick is held upright by a clip on the walls of the firebox. To remove, pivot it out from the bottom. See the illustration on the following page.

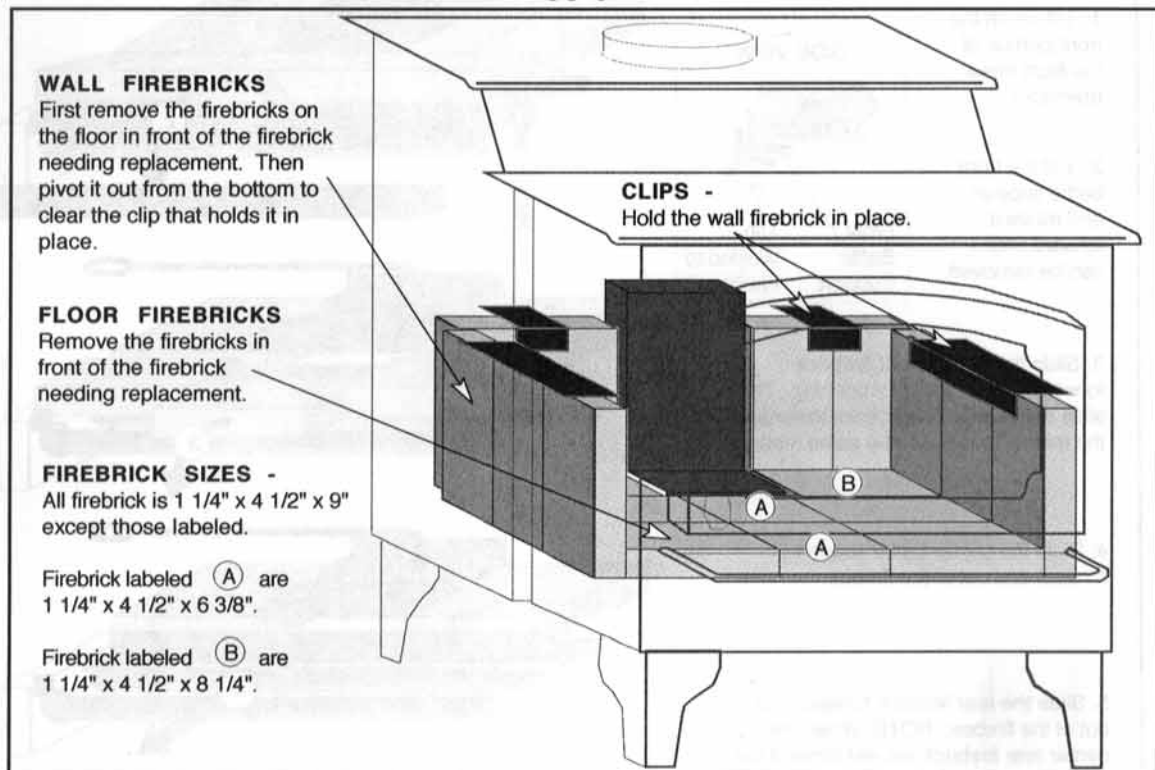

Baffle Removal and Replacement Instructions

The view below details the baffle components. Instructions for removal are on the following page.

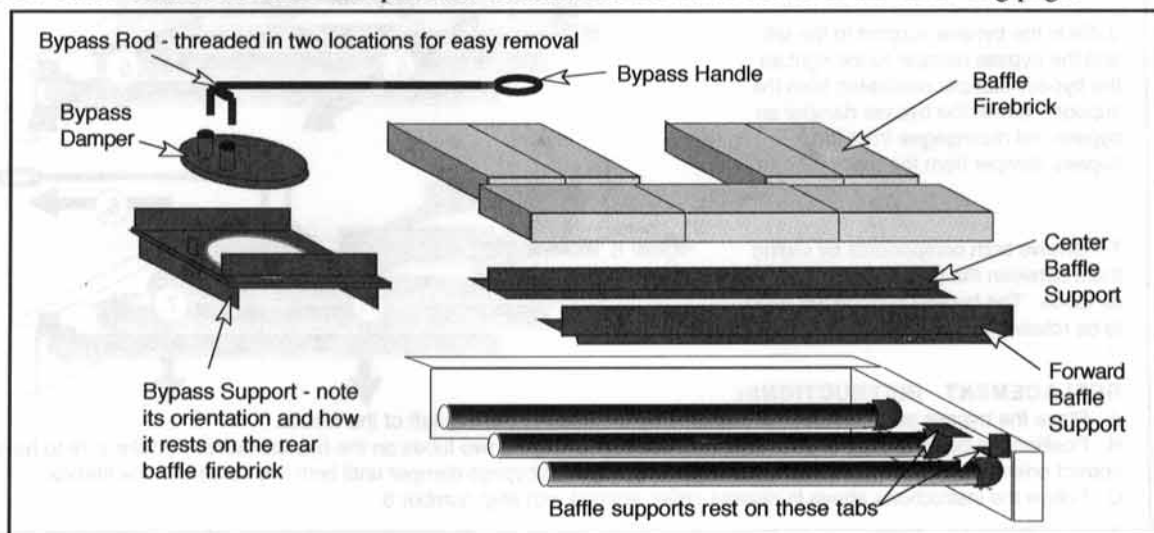

Baffle Removal and Replacement Instructions (continued)

All of the baffle components are removable to facilitate easy cleaning and repairs. Make sure the appliance is cool before removing any of the components. See the instructions on the following page for removing the secondary air tubes.

REMOVING BAFFLE COMPONENTS

1. Push the front firebricks up from the bottom.
2. Feed the front firebricks forward and out through the space between the front baffle support and the front of the firebox.
3. Repeat steps 1 and 2 for the rear baffle firebricks.
4. Remove the front and rear baffle supports in the same manner.
5. The bypass support and damper are difficult to remove and should only be removed if necessary. First remove the rear secondary air tube (see the following page for instructions). Slide the bypass holder forward until the bypass rod can be disconnected from the damper. Remove the damper by sliding it forward and off its holder. The bypass holder is removed by sliding it forward and rotating it downwards (the bypass holder fits very snug inside the firebox and is very heavy, making it difficult to remove). The bypass holder gasket rests on the side and rear air channels, try not to damage it when removing the bypass holder.

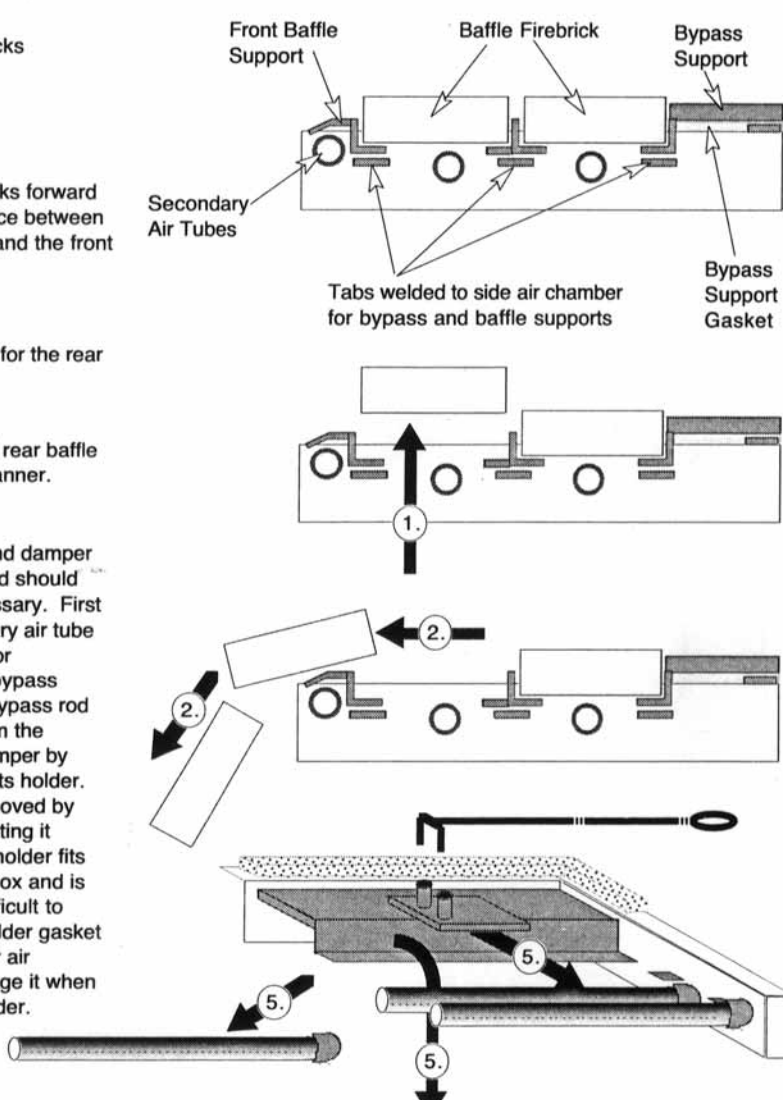

REPLACEMENT INSTRUCTIONS:

Follow the instructions in reverse order, making sure the following is fulfilled:

- Make sure the bypass holder is all the way back when reinstalled
- Once the bypass holder is in place, tuck the bypass holder gasket underneath it to form an air-tight seal
- Make sure the bypass damper is oriented correctly (see the illustration above)
- Make sure the bypass rod inserts correctly into the bypass damper
- Make sure the front baffle support is oriented correctly and put in flat

Baffle Removal and Replacement Instructions (Continued)

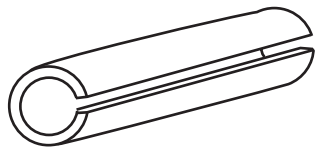
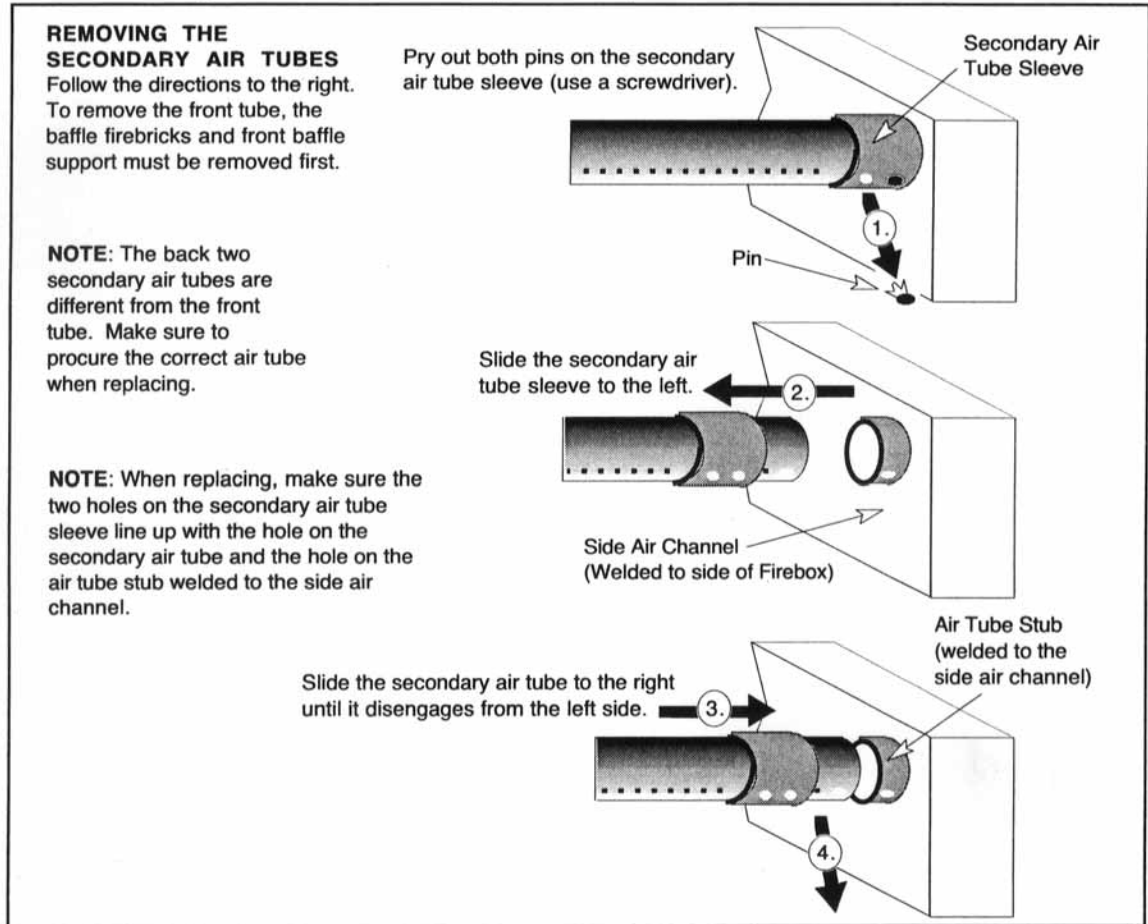

- New roll pins to hold air tube
- Hammer in to install
- Drive through into air tube to remove

TRAVIS INDUSTRIES WOOD PRODUCTS



TRAVIS INDUSTRIES
HOUSE OF FIRE

Wood Appliance Annual Service Procedure

Name _____ Phone # _____

Address _____

City _____ State _____ Zip _____

Appliance Brand _____ Model _____

Check Procedure	✓	Comments Corrections or Recommendations
Check Clearance to Combustibles		
Check Chimney Connector for Blockage/Creosote Etc.		
Check Chimney Integrity		
Tile		
Class A Chimney		
Liner System		
Check Chimney for Creosote Build-Up/Soot Etc.		
Check Flashing Seal		
Check Wall Trim Seal		
Check Attic Space Where		
Chimney Passes In/rogn		
Check Air Tube Integrity		
Check Baffle Retainers		
Check Baffle and Ceramic Brick		
Check Door Gasket & Glass Gasket		
Check Door Seal		
Check Air Control Operation		
Check Bypass Operation		
Clean Out Ashes		
Check Ash Pan Seal		
Empty Ash Pan		
Check Face Seal (Insert)		
Remove and Clean Convection Blower		
Clean Glass		
Polish Brass		
Finish/Looks Touch-Up		

TRAVIS INDUSTRIES WOOD PRODUCTS



Homeowner Questions About Operations:

Appliance Concerns:

Recommendations:

Date _____ Serviced By _____

Company _____

This Annual Service Was Reviewed With Me

Homeowner Signature

Next years Service Appointment:

Month _____ Date _____ Time _____

FPX WOOD FIREPLACES



Wood Burning Fireplaces

Catalytic Maintenance

Wood Fireplace Installation

FPX WOOD FIREPLACES

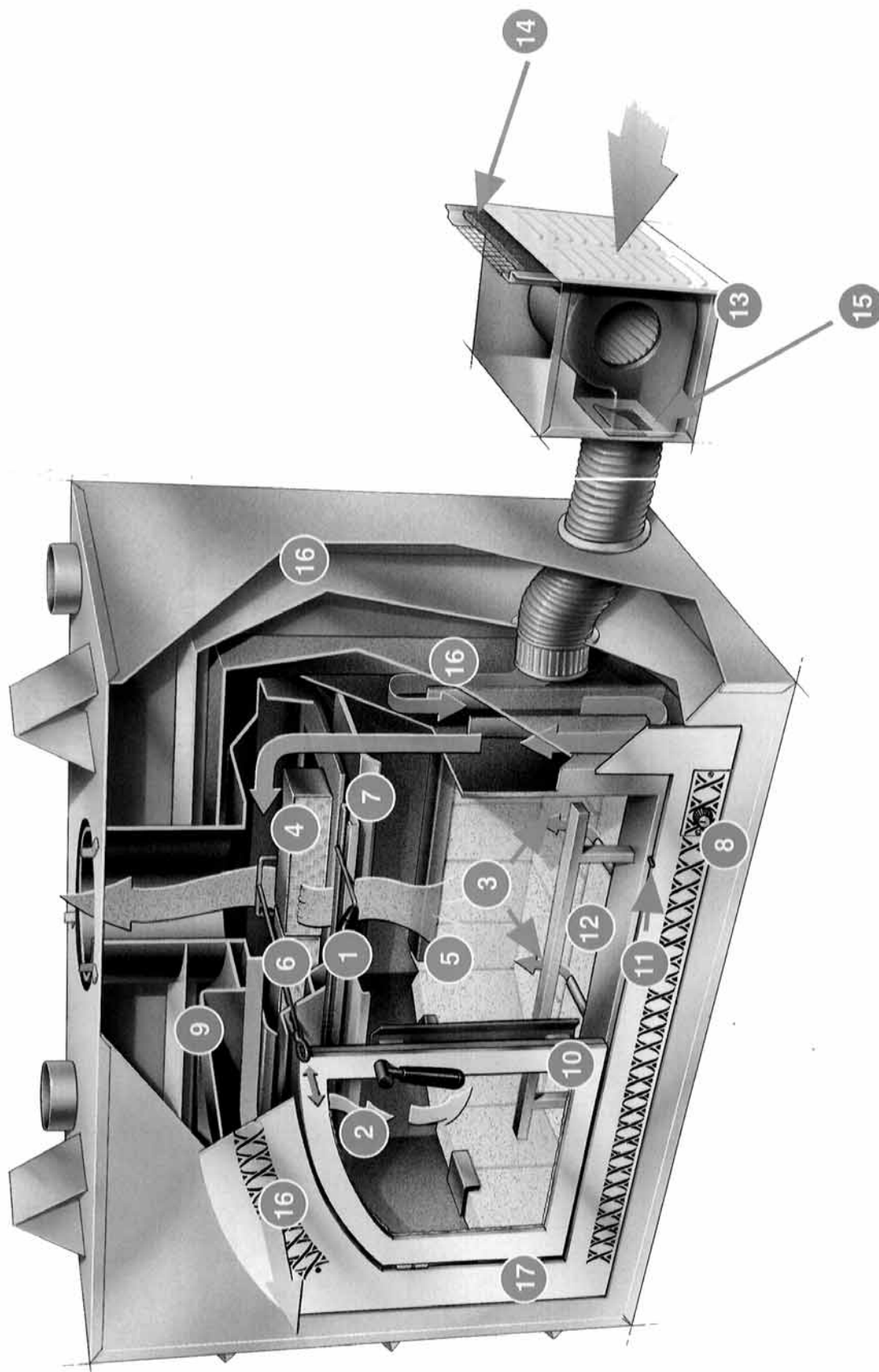

FPX WOOD FIREPLACES



Key To Cutaway Illustration

1. Single air control
2. Air wash keeps soot buildup to a minimum
3. Primary air inlet
4. Catalytic combustor produces low emissions
5. Refractory lined firebox
6. Catalytic bypass allows quick fire start and smoke free wood loading
7. Heavy steel baffle
8. Variable speed blower control
9. Heavy gauge, welded steel firebox
10. Large double door (single door option on 36 Elite)
Large fireviewing area
11. Blower micro switch shuts off blower when opening door(s)
12. Log retainer keeps wood from rolling out
13. 388 CFM blower draws fresh outside air to pressurize the home and provide outside air for combustion
14. Washable air filter
15. Barometric damper keeps cold air from entering home when fireplace is not in use
16. Convection chamber circulate and heats the air for maximum heat transfer
17. Finish face, available in black, gold plated and Artisan hand-hammers finishes

Posi-Pressure

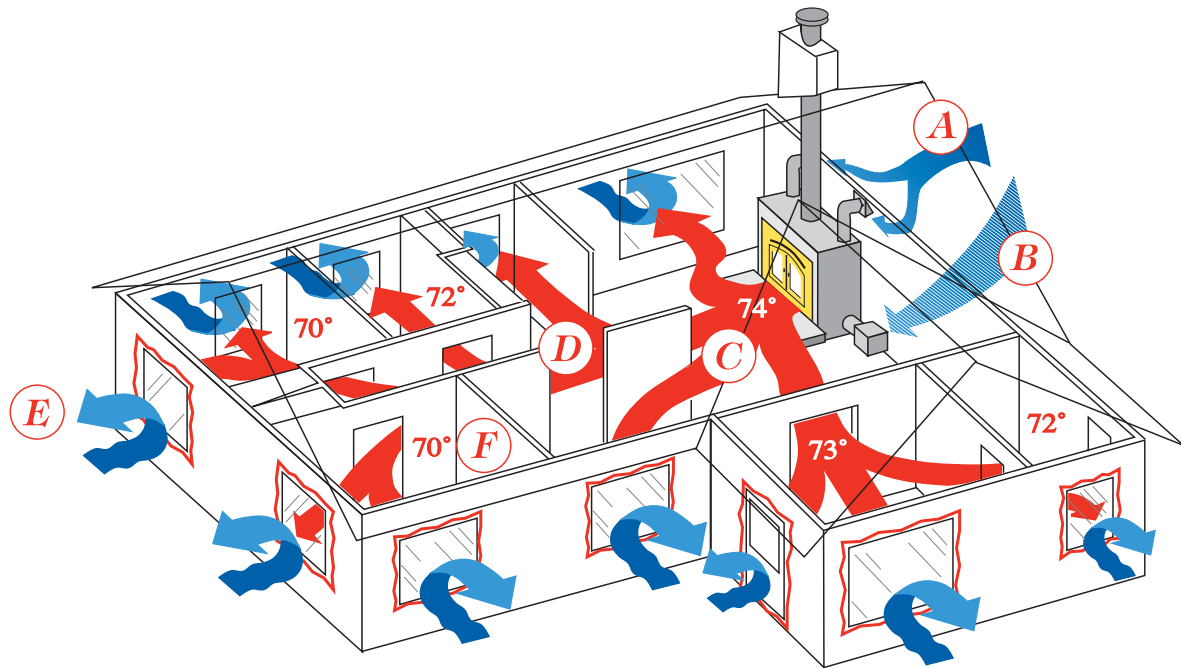

A. Cool air intake for cooling fireplace shell and chimney. After cooling the fireplace and chimney, this air exits out of the other wall of the chimney.

B. Outside Air is drawn in via a quiet 388 CFM blower, for Combustion & Posi-Pressure Distribution.

C. Outside air is heated and forced into your home through a unique process called "Posi-Pressure."

D. The pressurized heated air naturally "seeks out" and penetrates cold spaces, warming the entire home evenly.

E. By pressurizing the home you effectively seal cracks, leaks and other drafty spots by preventing cold air infiltration into your home.

F. The Fireplace Xtordinair heats evenly throughout your home, not just a room or two.

Catalytic Combustor

Catalytic Combustor

- Honeycomb Ceramic
- Coated With Noble Metal
- Reduces Ignition Temperature of Smoke By 50%

**NEVER BURN
WOOD WITH
GALVANIZED
NAILS!**

Will Cause the
combustor to
explode

- Due to the huge firebox size, a catalytic combustor is used to clean up the smoke as it leaves the fireplace.
 - Combustors are a honey-combed ceramic material.
 - The ceramic is coated with a noble metal which decreases the ignition temperature of the smoke passing through it by 50%.
 - The metal that is used for the coating is Platinum or Palladium.
 - Care must be taken not to burn colored newsprint, foam cups, paper plates, trash, etc.
- These material will quickly plug up and damage the combustor.
- **CAUTION:** The combustor will become brittle with time. Handle it with care.

FPX WOOD FIREPLACES

Maintaining Catalytic Burn-Off

This fireplace uses a catalytic combustor to increase heat transfer to the room and reduce emissions.

The catalytic combustor takes dirty smoke and turns it into extra heat and cleaner emissions.

NOTE: If the combustor is engaged (bypass closed) when the fireplace is still cool, it will not work, leading to dirty smoke, no extra heat, and a dirtier combustor.

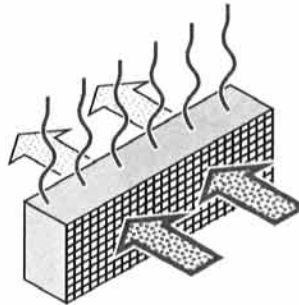

Warning: The bypass control becomes hot during operation - use gloves or a tool to prevent burns. Follow the directions below to utilize the combustor to its fullest potential.

- Keep the by-pass open (pulled out) until the fireplace becomes hot (approximately 15 to 30 minutes).
- Close the by-pass (push in) when the fireplace is hot.
- Keep the by-pass closed (pushed in) while the fireplace is operating, except when re-loading.

Hint: The combustor can be viewed through the glass from below. You will notice the combustor glowing red when the combustor is working effectively.

With the by-pass open (pulled out), the smoke passes through the by-pass and does not go through the combustor.

With the by-pass closed (pushed in), the smoke passes through the combustor.

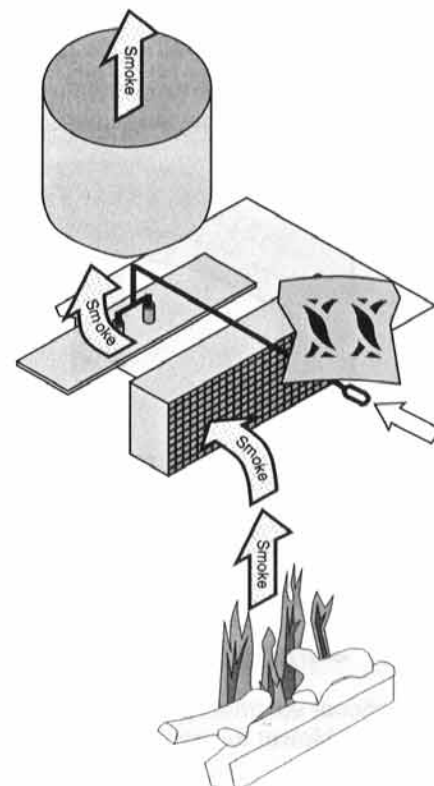
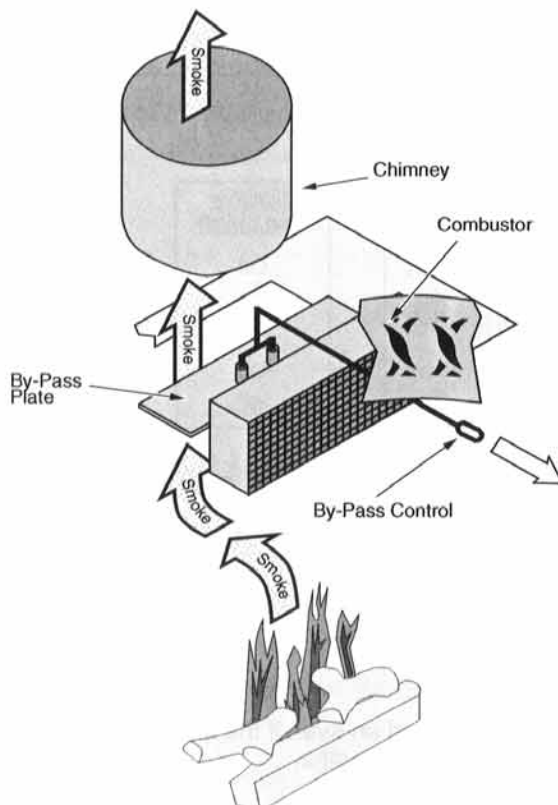

- An optional combustor temperature probe is available from your dealer. It allows you to monitor the combustor temperature, which lights off if the temperature is above 600° F.

Catalytic Combustor

- **Cleaning Ash From The Combustor**

- With the fireplace completely cool (at least two hours after the last coal has extinguished), use a vacuum cleaner to draw all ash from the combustor

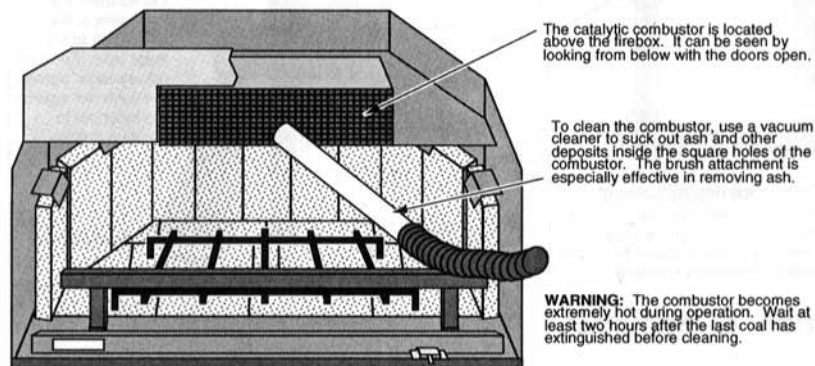

- **Cleaning The Combustor**

- Boil in a water/vinegar solution
- Rinse
- Boil in clean water
- Oven dry (350°F) or air dry for 24 hours

Replacing Catalytic Combustor 36 Elite & 44 Elite

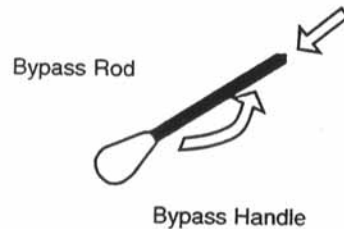

1. Pull the bypass all the way forward. Use a pair of pliers to unscrew the bypass rod. Remove the bypass rod (with handle attached).

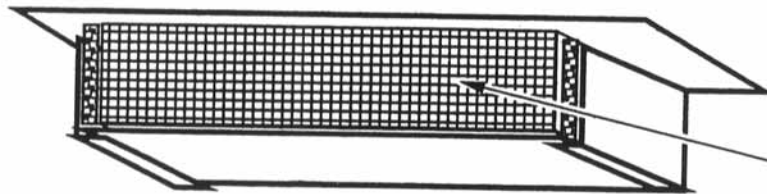

2. Remove the door and locate the combustor. It is located at the front of the firebox along the ceiling.

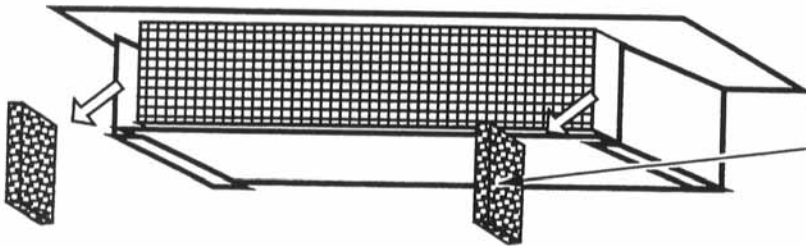

3. Remove the two pieces of kaowool on each side of the combustor.

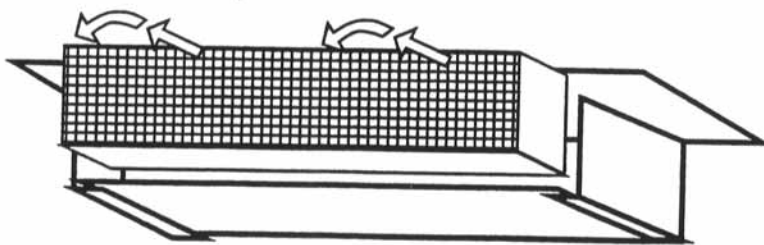

4. Slide the combustor forward. Then tilt it downwards to remove.

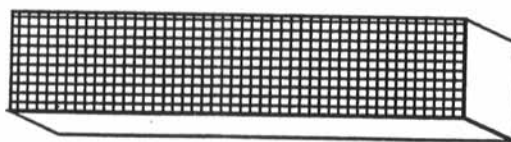

The combustor is wrapped in an inter ram gasket and surrounded with a metal protector.

FPX WOOD FIREPLACES



**TRAVIS INDUSTRIES
HOUSE OF FIRE**

Wood Fireplace Annual Service Procedure

Name _____ Phone # _____

Address _____

City _____ State _____ Zip _____

Appliance Brand _____ Model _____

Check Procedure	✓	Comments Corrections or Recommendations
Check Clearance to Combustibles		
Check Chimney for Blockage, Creosote		
Check Chimney Integrity		
Check Bypass Operation		
Check Steel Baffle		
Check Fire Grate		
Check Brick Refractory		
Check Catalyst and Gasket		
Check Thermo Disk		
Check Air Shutter		
Check Door Micro Switch		
Check Door Seal		
Check Door Gasketing		
Clean Glass and Check Gasket		
Clean Fire Box		
Check Air Blower Operation and Clean Filter		
Check Roof Flashing Seal		
Check Attic Penetration		
Check Outside Seal and Air Ducts and Blowers		
Check Blower Rheostat and Summer Switch		

FPX WOOD FIREPLACES



Homeowner Questions About Operations:

Appliance Concerns:

Recommendations:

Date _____ Serviced By _____

Company _____

This Annual Service Was Reviewed With Me

Homeowner Signature

Next years Service Appointment:

Month _____ Date _____ Time _____

FPX WOOD FIREPLACES



Mantel Requirements

- The optional mantel must be a minimum 23" above the top of the faceplate (61" above the base)
- The mantel must not extend more than 8-1/2" in front of the faceplate.
- Mantel side columns that protrude more than 3/4" must maintain an 18" clearance to the faceplate

Hearth Requirements

- ? Local building codes may require a minimum hearth requirement different of what this manual states
- Hearth must extend 20" in front of the faceplate when it is not elevated (see local building codes). Hearths raised 6-1/2" must extend a minimum 18".
- Hearth must extend a minimum 8" to both sides of the faceplate (60" wide)
- Hearth must be a minimum 1" thick of cement board (or equivalent)
- Hearth must not rise more than 6-1/2" above the base of the fireplace

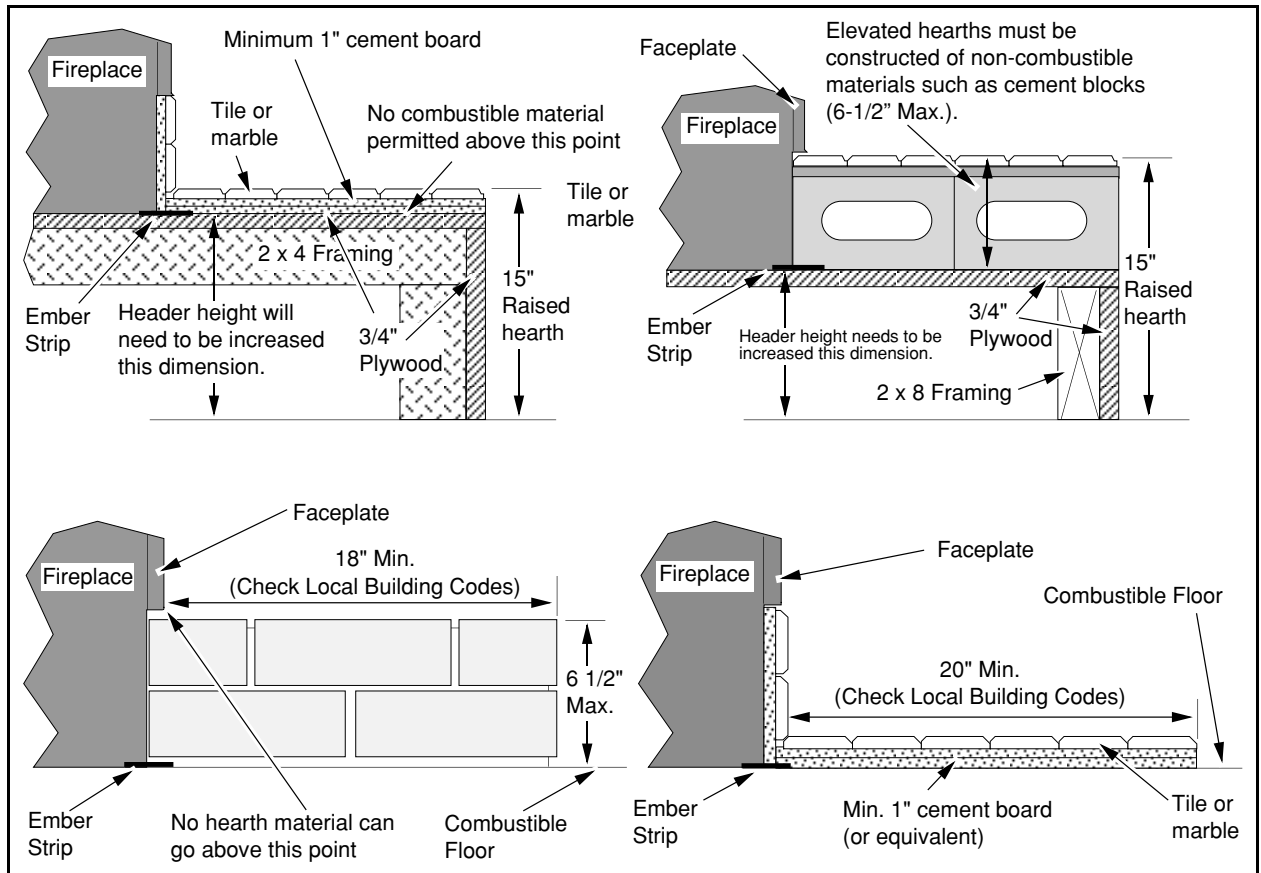
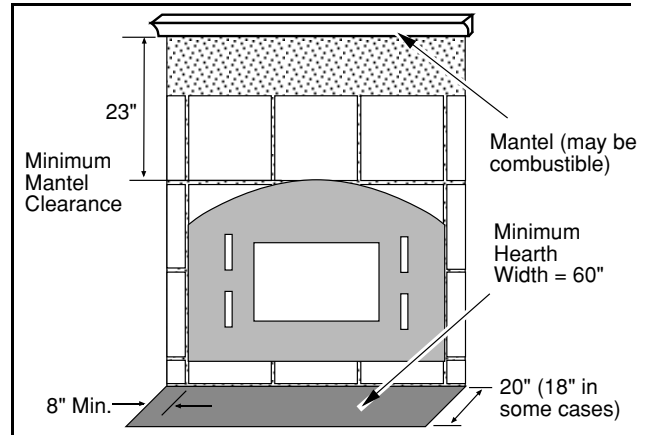

FPX WOOD FIREPLACES



Raised Fireplaces

- If the fireplace is raised more than 15" above the sub-floor, the fireplace enclosure will have to be raised accordingly (see "Minimum Framing Dimensions" on page 3).
- + The fireplace may be placed on a platform designed to support the fireplace and vent (Approximately 600 Lbs.).

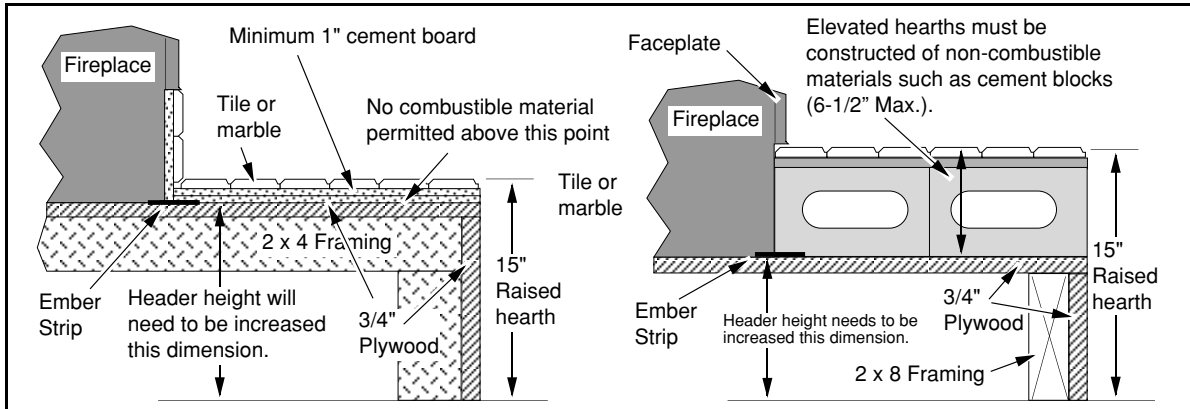

Facing Requirements

NOTE: Artisan faces vary in size. If the facing is over 1" thick (brick, river-rock, etc.) use the face being installed to create a template.

- The fireplace is shipped with a set-up face that is 1/16" larger on the top, bottom and each side than the faceplate. Leave the set-up face in place to act as a template when installing the facing.
- The fireplace requires 1/2" thick concrete-board or other non-combustible to extend from the header to the base of the fireplace and to the framing members on both sides (do not use sheetrock or drywall).
- The non-combustible facing must extend a minimum of 12" above and 2-1/2" to each side of the faceplate.
- The non-combustible facing must be a minimum 1" thick
- The facing may be attached to the front of the fireplace with screws. Do not penetrate the fireplace more than 3/4".

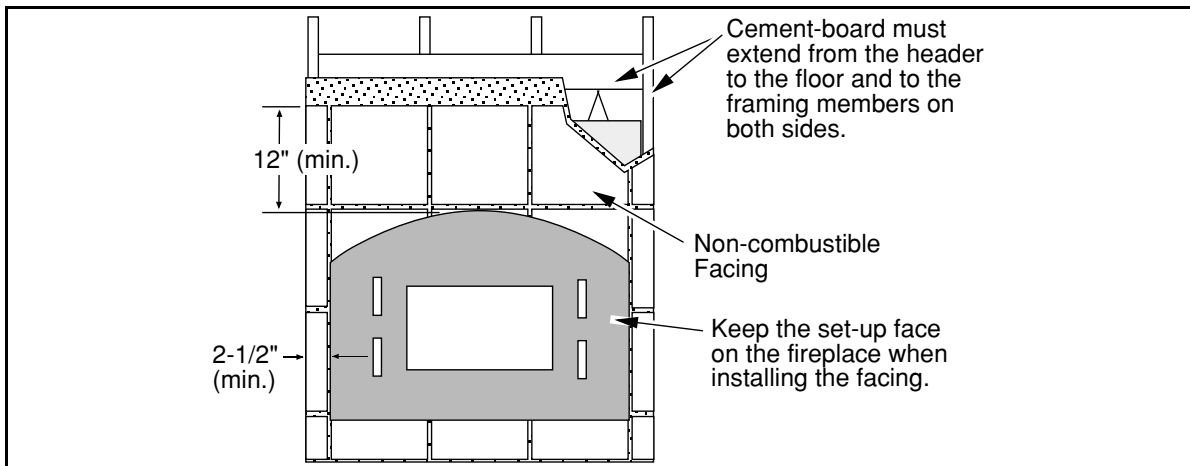

- Facing may be installed so it inserts behind the faceplate. NOTE: the faceplate protrudes 1" from the front of the fireplace, has a 1/8" overlap on the sides, and 1/4" overlap on top.

FPX WOOD FIREPLACES

Clearances to Combustibles

- ! Follow the clearances listed below - do not follow the clearances listed in the chimney instructions
- Maintain a 2" clearance from the chimney to combustibles (measured horizontally)
- Use offsets, if necessary, to maintain clearances
- In the area above the fireplace before the chimney penetrates the ceiling (use a firestop), the chimney must maintain the clearances listed below:
5" to the rear of the chimney
4-1/2" to the front of the chimney

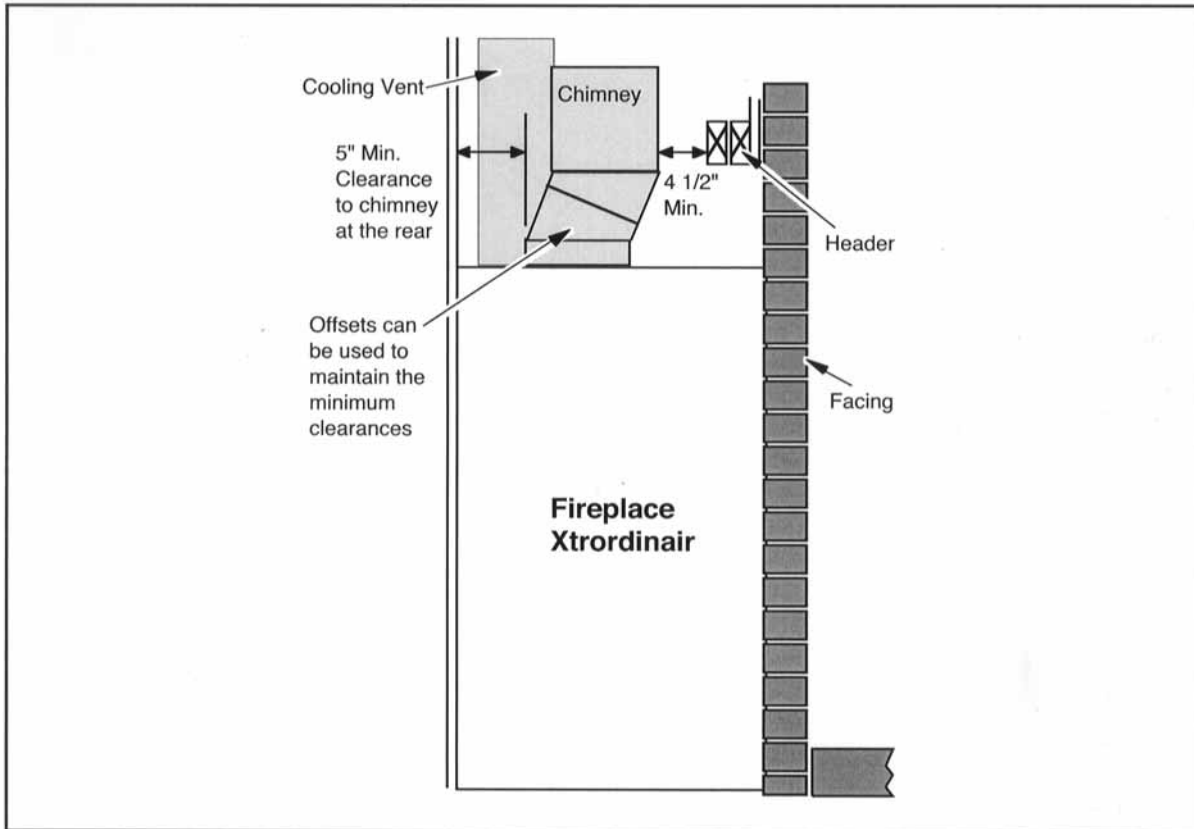

Firestops

- Whenever the chimney penetrates a floor or ceiling a firestop is required on the bottom side of the floor joists
- When passing through an attic the firestop must be placed on the attic side of the joists
- When the chimney passes through a living space it must be totally enclosed (maintain the minimum 2" clearance to combustibles)
- The space between frames that hold the firestop in place should be measured as follows:

Temco	16"
Superior	16 1/2"
FMI	16 1/2"
Marco	16 1/2"

NOTE: Many firestops are designed for a 1" clearance, this fireplace requires a 2" clearance.

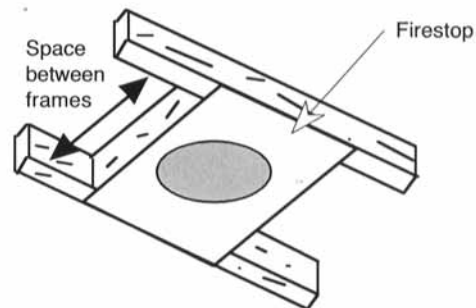

FPX WOOD FIREPLACES

Chimney Requirements

- Use one of the following brands and type of chimney:
 - Temco 82
 - Superior TF8
 - FMI 8DM
 - Marco 8D

Chimneys Part Numbers

Chimney Components	Temco 82	Superior TF8	FMI 8DM	Marco 8D
12" Chimney Section	8212D	TF8-12	12-8DM	12 - 8D
18" Chimney Section	8218D	TF8-18	18-8DM	18 - 8D
24" Chimney Section	8224D	---	24-8DM	----
36" Chimney Section	8236D	TF8-36	36-8DM	36 - 8D
48" Chimney Section	8248D	TF8-48	48-8DM	48 - 8D
Offsets	8232E	TF8-30, TF8-E30	30E-8DM	30E - 8D
Flashing	8206F	8-F6	6F8 or 12F8	12F - 8D
Chimney Cap	8203D	TF8-CTO	RTL-8HT	BT - 8D
Roof Support	8204S	8-54	38 RS	12CPS - 8D
Firestop Spacer	---	8FS-2	FS-8DM	FS30 - 8D

Chimney Connection to Fireplace

- Each brand of chimney has a slightly different outside diameter. To accommodate this, the fireplace has three "L" brackets (outer liner connectors) on the top of the fireplace can. Center a section of chimney over the chimney opening and mark the exterior location of the chimney. Then reposition the "L" brackets, if necessary, so they are directly adjacent the exterior of the chimney. Use a drill with a 5/16" driver bit to re-install the "L" brackets (use the existing sheet metal screws).

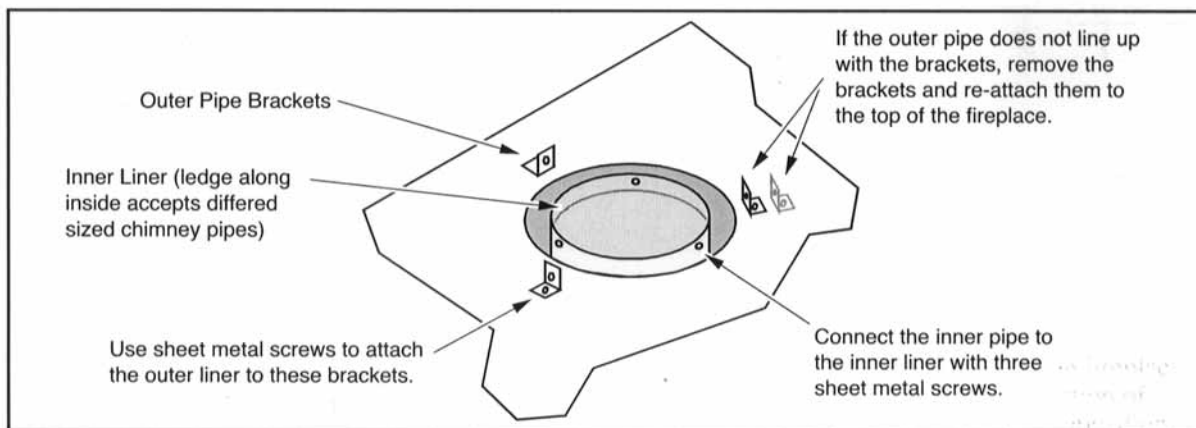

- When attaching the chimney to the fireplace, first slide down the inner liner of the chimney pipe into the inner liner of the fireplace. Certain brands of chimney pipe will stop at the ledge, while others will insert beyond the ledge. When the chimney pipe is fully seated and aligned, drill three holes in the chimney pipe where it lines up with the holes in the fireplace inner liner. Secure the fireplace to the chimney pipe with three sheet metal screws. If there are any large gaps between the chimney pipe and fireplace, use furnace cement to seal (allow 24 hours to dry before burning the fireplace).

FPX WOOD FIREPLACES



Cooling Vents

! The cooling vents provide cooling air for the fireplace and chimney system. Failure to correctly install the cooling vents will lead to an extremely dangerous installation and possibly a fire.

- The two cooling vents must be installed so as to route air from the outside to the two starter collars on the top rear corners of the fireplace. Secure the vents to the collars using high-temperature aluminum tape and/or sheet metal screws.
- A maximum of two 90° bends may be used on each vent. However, if a 180° bend is placed directly off the starter collar, one additional 90° bend may be used.
- The maximum distance for the cooling ducts is listed below:

When the vertical rise is between:	The maximum horizontal run may be:
6' and 10'	5'
3' and 6'	15'
1' and 3'	20'
0' and 1'	25'

- Included with the fireplace are two 12' lengths of vent, use a connector and seal if adding more length
- The duct terminations must be located so they can not be blocked (e.g. snow drifts)

- Included with the fireplace is a set of storm collars and vent hoods. Place the collars around the vent on the exterior and attach with screws or caulking to seal the wall from the vent penetration. Place the hood, with open portion facing down, over the cooling vents and secure.

- ? The cooling air duct terminations may be installed to draw air from a ventilated crawl space or attic if approved by local building codes.
NOTE: certain codes require a fire curtain damper in these cases.

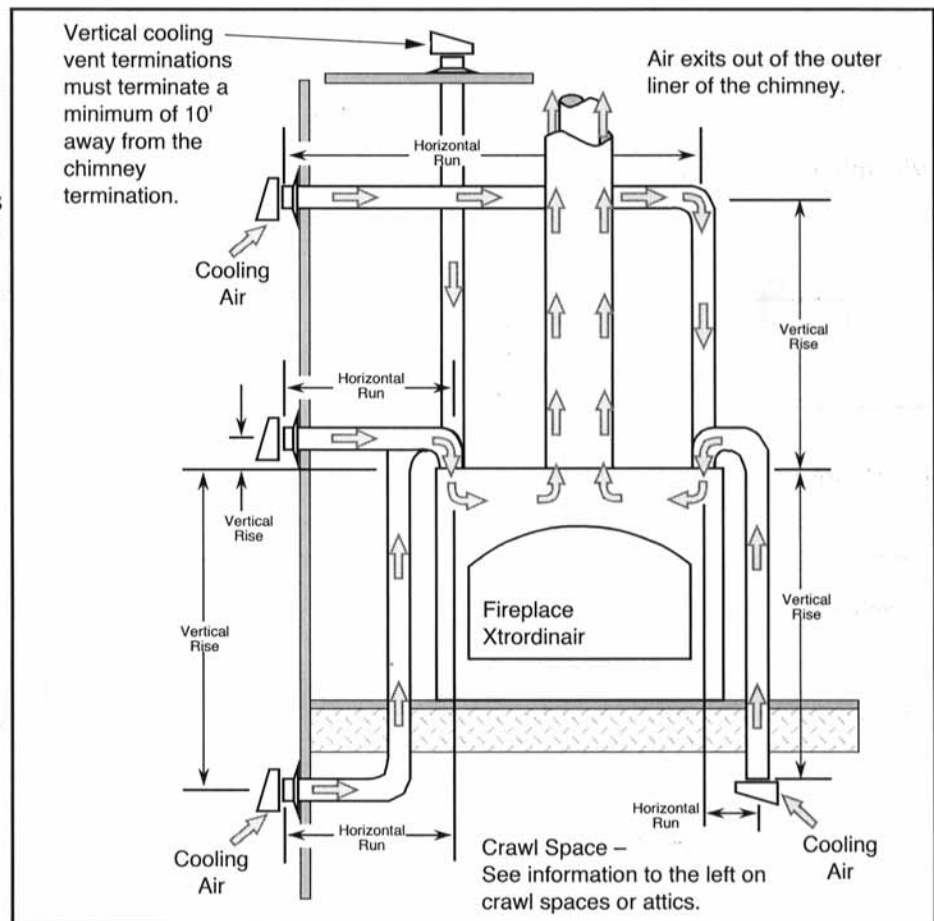

FPX WOOD FIREPLACES

Installation Requirements for Cold Environments

If you live in the area depicted in black (see Figure 4), you must install a cooling air "P" trap as detailed below and install the blower on an internal wall. In addition, make sure the homeowner follows the requirements shown below to help minimize cold air being pulled into the fireplace when it is not in use.



Figure 4

Install the Blower in an Internal Location

In cold environments the blower must be positioned on an internal wall (see Figure 5). This eliminates any chance of any outside air being drawn into the convection chamber from the blower location.

NOTE: Do not place the blower inside a garage or other area that may circulate fumes.

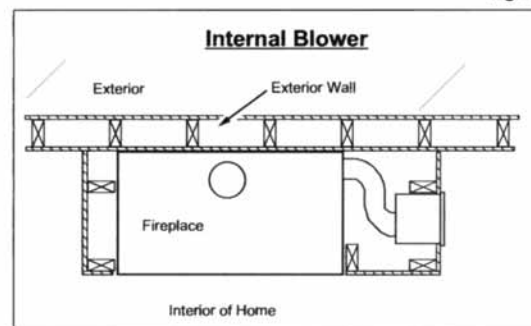

Figure 5

Cooling Air "P" Trap

When installing the cold air ducts, make sure to include a "P" trap in the design (see the illustration to the right). This helps slow cold air from circulating through the cooling air chamber.

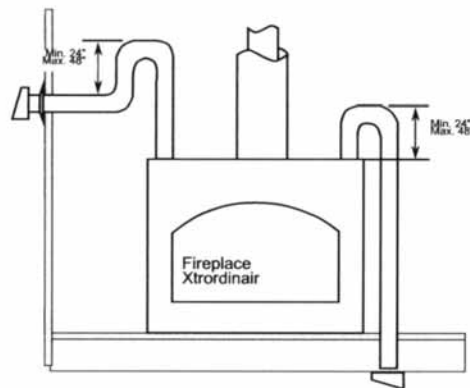

Figure 6

Daily Requirements for Homeowners

Humidity

Make sure the humidistat is set correctly. The chart below details the correct setting for the temperature you are experiencing outdoors.

Outdoor Temperature		Recommended Humidity Controller Setting
°F	°C	
-20	-29	15
-10	-23	20
0	-18	25
+10	-12	30
+20	-7	35
>+20	>-7	40

Note: If using a humidifier, let the homeowner know that it should be shut off or turned to a lower setting to eliminate condensation.

Other Items

- Make sure the bypass is shut when the fireplace is not in use.
- Minimize the use of exhaust fans in the home when the fireplace is not in use.

FPX WOOD FIREPLACES



TRAVIS INDUSTRIES
HOUSE OF FIRE

Blower

The external blower pushes air through blower duct to the fireplace, where it is heated and distributed into the room. The blower may be located to draw air from the exterior of the home, producing positive pressure inside the home. Or, if desired, the blower may be located to draw air from the interior of the home.

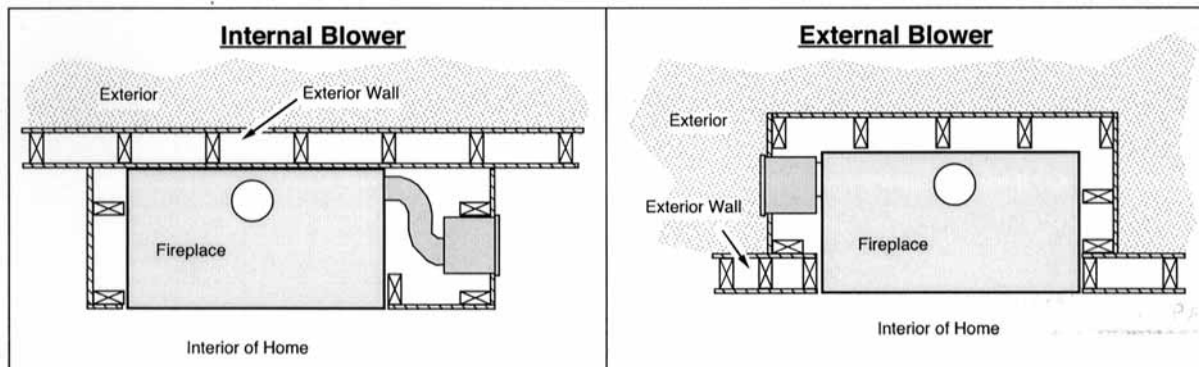

- Do not draw air from confined areas or from a garage or area containing fumes or emissions. The blower inlet must be a minimum 36" below any exhaust vent.
- The blower may be installed to draw air from a crawl space or attic if approved by local building codes. **NOTE:** certain codes require a fire curtain in these cases.

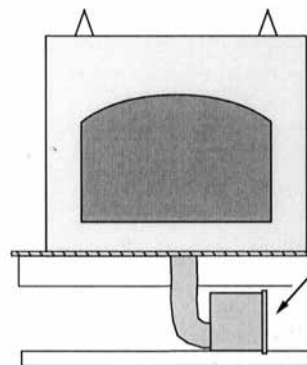

The blower may be placed in a ventilated crawl space (if approved by the local building department).

NOTE: The blower may be placed with the grill facing down. Do not place the blower on its side.

Blower Duct Connection

- The shorter the blower duct, the greater the air flow.
- The blower duct may connect to the right side, left side, or bottom of the fireplace. Each location is sealed with a cover plate. Use a 5/16" nutdriver to remove the cover plate blocking the location you wish to use (NOTE: if using the bottom location, remove the 8-1/2" by 6-1/4" air deflector directly above the cover plate). Insert the starter section into the blower hook-up hole and bend the flanges outwards, locking the starter section in place.
- Attach the flex duct to the collar on the blower box and start collar using duct tape and/or screws
- The maximum length for 6" diameter blower duct is 15' (use the included duct & start collar)

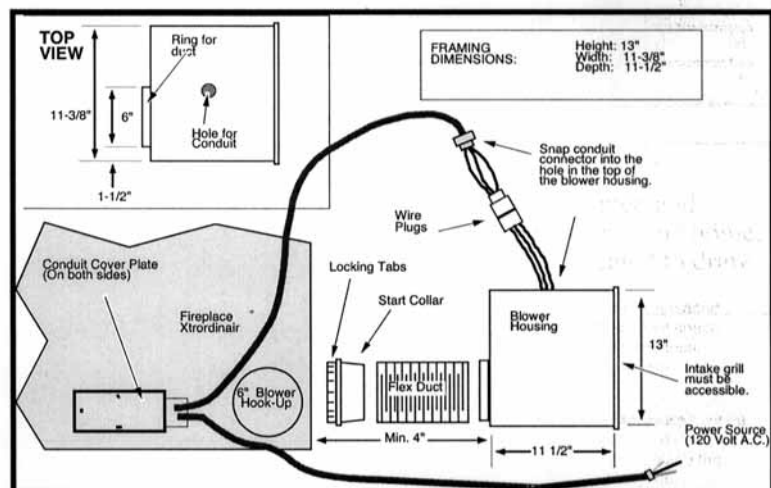

FPX WOOD FIREPLACES



TRAVIS INDUSTRIES
HOUSE OF FIRE

Blower Duct Connection (continued)

- The maximum length for 8" diameter blower duct is 25' (use two 6" to 8" adapters)
- A maximum of two 90° bends may be used.
- The blower, if located on an external wall, must be weatherproofed. Remove the blower cover and install the blower. Apply caulk around the perimeter of the blower housing where it contacts the external wall and vapor barrier (apply sparingly). Replace the blower cover.

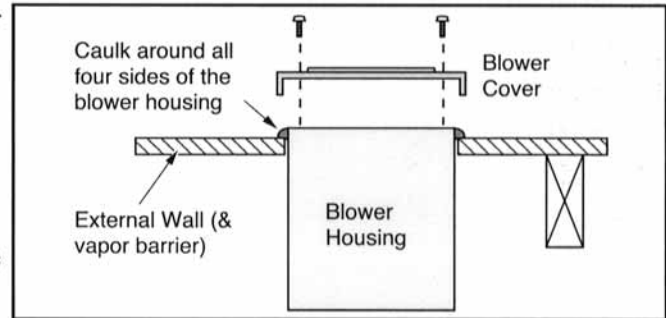

Blower Electrical Connection

- Connect the electrical conduit to a 120 Volt, 60 Hz (2 Amp) electrical supply. Use a junction box to protect the electrical connection.
- Connect the blower conduit to the blower box by attaching the two molex connectors together. Insert the molex connectors into the blower box. Then attach the conduit to the blower box by inserting it into the top until it snaps in place.

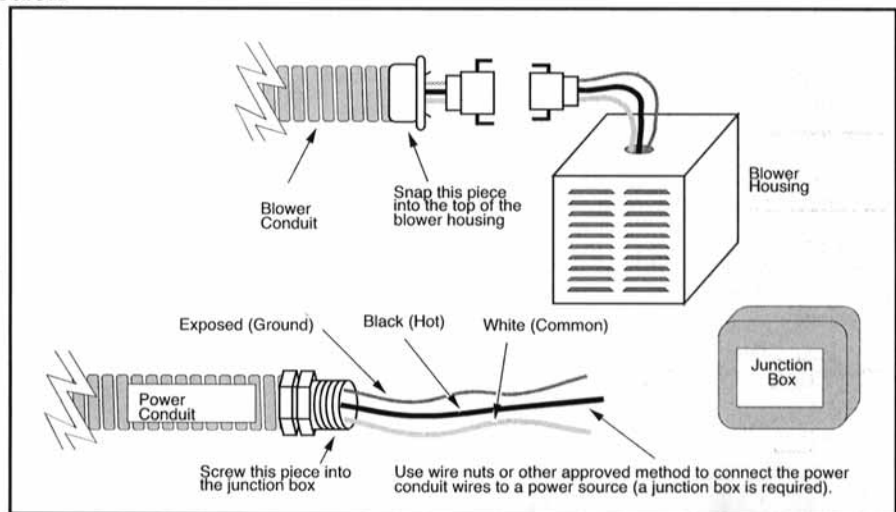

- ! Do not run either conduit over the top of the fireplace or within 2" of the chimney
- If the blower or power supply is located to the left, the electrical conduit(s) may be directed to the left side of the fireplace. To do this, remove the conduit cover plate on both sides of the fireplace. Feed the conduit(s) through the hole on the right side and out the left side (removing the cover allows the conduit to be fed through without kinking). Switch the cover plates by attaching the right cover plate to the left side and vice-versa.
- The blower utilizes a filter that requires periodic cleaning - see the illustration below.

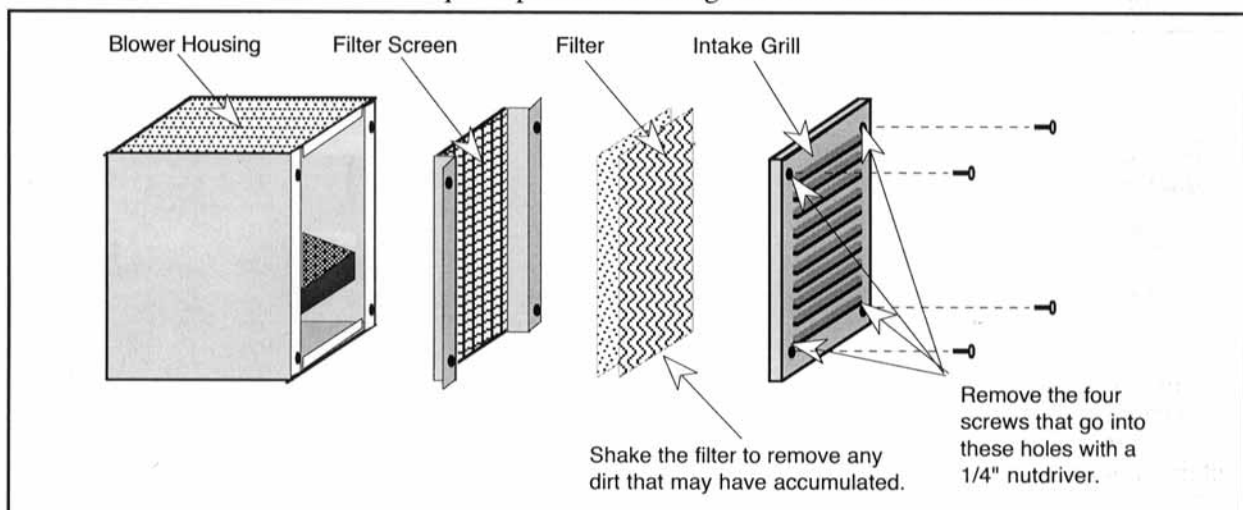

TRAVIS ELECTRIC FIREPLACES



Avalon Electric Fireplace -36E

Basic Frame or choose from one of these designer faces



Victorian Lace
Face
Black Painted



Victorian Lace
Face
Black Nickel
Plated with
Nickel Accents



Bungalow Face
Black
Textured Steel

Lopi Electric Fireplace -36E

Basic Frame or choose from one of these designer faces



Wilmington Face
Black Painted



Wilmington Face
Black Painted
Arabesque Grills



Wilmington Face
Pewter Plated



Wilmington Face
Pewter Plated
Arabesque Grills

FPX Electric Fireplace -36E

Basic Frame or choose from one of these designer faces



Classic Arch
Black



Metropolitan
Black Painted



French Country
Antique Gold



Artisan
Charcoal Painted



Matrix
Brushed Nickel

TRAVIS ELECTRIC FIREPLACES



36 E ELECTRIC FIREPLACES

- Dimplex™ licensed technology with Travis Industries face designs
- Fabricated steel firebox featuring patented flame technology
- Realistic wood-like flame
- Instant ambiance of a real fireplace to any living area in just minutes
- Safe clean operation - stay cool glass, no combustibles to vent
- Effective heat - Thermostatically controlled 1500W fan provides supplemental heat for up to 400 sq. ft.
- Plug and Play - simply plug into any 110v outlet
- Clean air purification system - filters your rooms (12' x 14') air four time per hour
- Variable speed flame image
- Pulsing, glowing logs and ember bed
- Brick liner appearance
- Variable interior light
- Multi-function Remote Control:
 1. Flame On/Off
 2. Clean Air On/Off
 3. Flame Speed
 4. Interior Accent Light
 5. Room Temperature Monitor
 6. Set Temperature
 7. Sleep Timer
- Year-round enjoyment of the fire

TRAVIS ELECTRIC FIREPLACES



36 E FIREPLACES

IMPORTANT INSTRUCTIONS

SAVE THESE INSTRUCTIONS

PLEASE RETAIN THIS USER'S GUIDE FOR FUTURE REFERENCE

When using electrical appliances, basic precautions should always be followed to reduce the risk of fire, electric shock, and injury to persons, including the following:

1. Read all instructions before using the electric fireplace.
2. The heater is hot when in use. To avoid burns, do not let bare skin touch hot surfaces. The trim around the heater outlet becomes hot during heater operation. Keep combustible materials, such as furniture, pillows, bedding, papers, clothes, and curtains at least 3 feet (0.9m) from the front of the unit.
3. Extreme caution is necessary when any heater is used by or near children or invalids and whenever the unit is left operating and unattended.
4. Always unplug the electric fireplace when not in use.
5. Do not operate any unit with a damaged cord or plug, or if the heater has malfunctioned, or if the electric fireplace has been dropped or damaged in any manner. Return heater to authorized service facility for examination, electrical or mechanical adjustment, or repair.
6. Do not use outdoors.
7. The electric fireplace is not intended for use in bathrooms, laundry areas and similar indoor locations. Never locate heater where it may fall into a bathtub or other water container.
8. Do not run the cord under carpeting. Do not cover cord with throw rugs, runners, or the like. Arrange cord away from traffic area and where it will not be tripped over.
9. To disconnect the unit, turn the controls off, then remove the plug from the outlet.
10. Do not insert or allow foreign objects to enter any ventilation or exhaust opening as this may cause an electric shock or fire, or damage to the heater.
11. To prevent a possible fire, do not block air intake or exhaust in any manner. Do not use on soft surfaces, like a bed, where openings may become blocked.
12. All electrical heaters have hot and arcing or sparking parts inside. Do not use in areas where gasoline, paint, or flammable liquids are used or stored or where the unit will be exposed to flammable vapors.
13. Do not modify the electric fireplace. Use it only as described in this manual. Any other use not recommended by the manufacturer may cause fire, electric shock or injury to persons.
14. Avoid the use of an extension cord. Extension cords may overheat and cause a risk of fire. If you must use an extension cord, the cord must be No. 16 AWG minimum size and rated no less than 1875 watts.
15. Do not burn wood or other materials in the electric fireplace.
16. Do not strike the fireplace glass.
17. Always use a certified electrician should new circuits or outlets be required.
18. Always use properly grounded, fused and polarized outlets.
19. Disconnect all power supply before performing any cleaning, maintenance or relocation of the unit.
20. When transporting or storing the unit and cord, keep in a dry place, free from excessive vibration and store so as to avoid damage.

NOTE: Procedures and techniques that are considered important enough to emphasize.

CAUTION: Procedures and techniques which, if not carefully followed, will result in damage to the equipment.

WARNING: Procedures and techniques which, if not carefully followed, will expose the user to the risk of fire, serious injury, illness or death.

TRAVIS ELECTRIC FIREPLACES



36 E FIREPLACE FRAMING

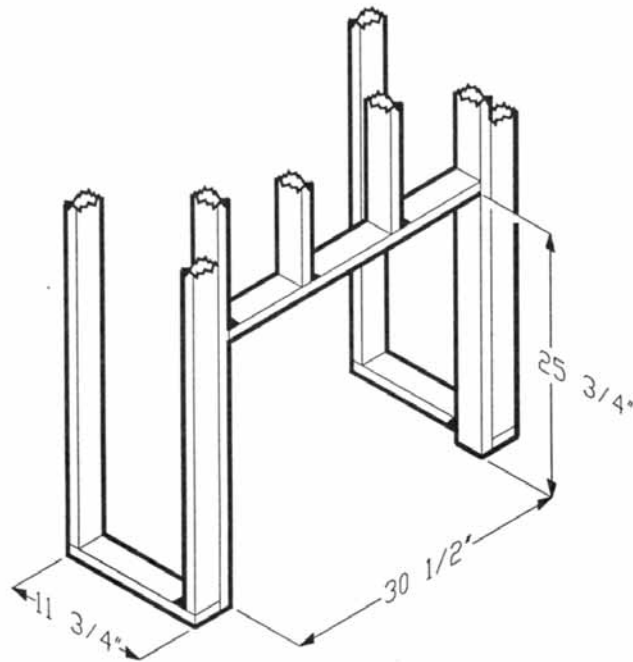

NEW WALL CONSTRUCTION

1. Select a suitable location that is not susceptible to moisture and is away from drapes, furniture and high traffic.
2. Place the fireplace in the desired location to see how it will look in the room.
3. Mark the desired location on the floor and store the fireplace in a safe, dry and dust free location.
4. Use studs to frame an opening of 30 1/2" wide X 25 3/4" high X 11 3/4" deep.

Option #1-The power cord can be lead from behind the trim and along the wall to an outlet near the fireplace.

Option #2-A new outlet can be installed inside the new frame construction. Plug the unit into a 15Amp/120Volt outlet. If the cord does not reach, you may use an extension cord rated for a **minimum of 1875 watts**.

CAUTION

TRAVIS ELECTRIC FIREPLACES

36 E FIREPLACE OPERATION

OPERATION

ELECTRIC FIREPLACE MANUAL CONTROL

The manual controls for the fireplace are located in the lower right hand corner.

A. Main On/Off Switch

Supplies power to the 3 position manual control switch.

B. 3 Position Manual Control Switch

Remote (right position): The unit is operated with the remote control.

Flame (center position): The flame effect is turned ON.

Flame & Heat (left position): The flame effect and heater are turned ON simultaneously. When the manual control is in the **Flame & Heat** position the heater does not run on the remote operated thermostat.

NOTE

When the manual control switch is in the **Flame** and **Flame & Heat** positions, the fireplace unit will not operate with the remote control.

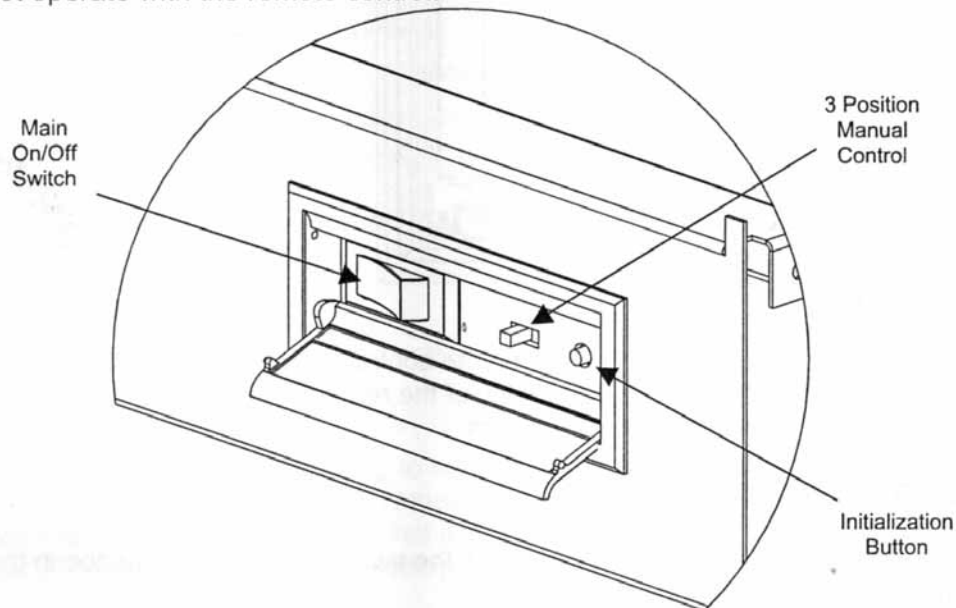
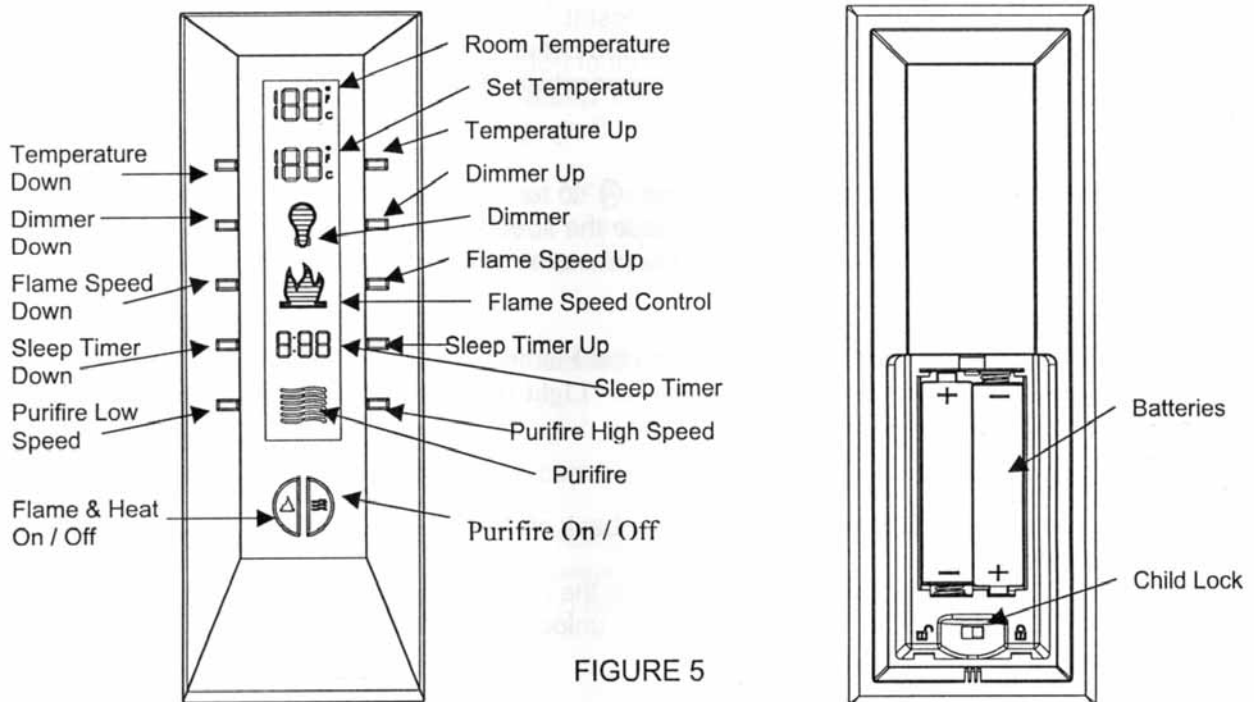

FIGURE 2

TRAVIS ELECTRIC FIREPLACES

36 E FIREPLACE REMOTE

REMOTE CONTROL FUNCTIONS



FLAME/HEAT ON/OFF BUTTON

Press the "Flame/Heat On/Off" button  to turn the Flame/Heat function **ON**. When the "Set Temperature" is higher than the "Room Temperature" the heat will come on. To turn the heat off, lower the "Set Temperature" so that its setting is lower than the "Room Temperature". The default temperature setting is 72°F (22°C).

NOTE

When using the remote control the heater runs on a thermostat. Press the "Temperature Up" or "Temperature Down" button to adjust the set temperature. Once the desired set temperature is reached the heater will turn **OFF**. The heater will cycle **ON** and **OFF** to maintain the desired set temperature.

TRAVIS ELECTRIC FIREPLACES

36 E FIREPLACE REMOTE

PURIFIRE ON/OFF BUTTON

Press the "Purifire™ On/Off" button  to turn the Purifire™ function **ON**. When the Purifire™ function is **ON** the Purifire™ symbol will flash. When off the symbol will be solid. The default setting for the Purifire™ is set at low speed. Press the "Purifire™ On/Off" button to turn the Purifire™ function **OFF**.

NOTE

To turn the Flame/Heat and Purifire™ "OFF" at the same time, press both  control buttons simultaneously.

SET TEMPERATURE

1. Press "Flame Heat On/Off" button to turn fireplace on.
2. Press "Temperature Up" to raise thermostat.
3. Press "Temperature Down" to lower thermostat.
4. Press both "Temperature Up" and "Temperature Down" to change °F to °C.

FLAME SPEED

1. Press the "Flame/Heat On/Off" button  to turn the Flame/Heat **ON**.
2. Press the "Flame Speed Up" to increase the speed of the flame.
3. Press the "Flame Speed Down" to decrease the speed of the flame.

LIGHT DIMMER

1. Press the Flame/Heat button  to turn the Flame/Heat **ON**.
2. Repeatedly press the "Light Dimmer Up" or "Light Dimmer Down" button to decrease or increase the brightness of the upper lights.

CHILD LOCK

1. Depress tab on the battery cover on the back of the remote transmitter and remove the battery cover.
2. Move "Child Lock" tab to the right to lock the remote transmitter.
3. Move "Child Lock" tab back to the left to unlock the remote transmitter.
4. Replace the battery cover.

NOTE

To temporarily unlock the remote transmitter press (in order) "Temperature Down" then "Temperature Up" then "Dimmer Down".

When the remote transmitter's back light is illuminated the "Child Lock" is bypassed.

When the back light is off the "Child Lock" is re-activated.

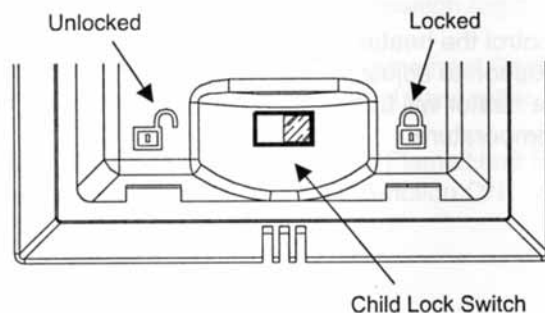

Figure 6

TRAVIS ELECTRIC FIREPLACES

36 E FIREPLACE ACCESS

To access the lower light bulb area:

NOTE

Figure 7

1. Slide fireplace out of mantel 2-3 inches.
2. Remove 4 Phillips screws from the right side of trim.
3. Slide glass to right side of fireplace to remove.
4. Pull the front edge of the plastic ember bed or plastic grate up and forward until the rear tab releases from the ledge located at the bottom of the mirror.

IMPORTANT

Only handle the logset by the emberbed.

NOTE

Logset fits tightly into firebox, some force may be necessary to remove.

5. Set logset in front of fireplace.
6. Disconnect the logset LED wire harness from unit.
7. Unscrew bulbs counter clockwise.
8. Insert new bulbs.
9. Reconnect the logset LED wire harness.
10. Replace the logset by inserting the front edge of the fireplace and push down on the rear edge of the emberbed until it snaps into place. (Figure 8)

NOTE

Ensure the logset is installed tightly under the back ledge to prevent light leakage.

11. Slide front glass back into position and attach trim.

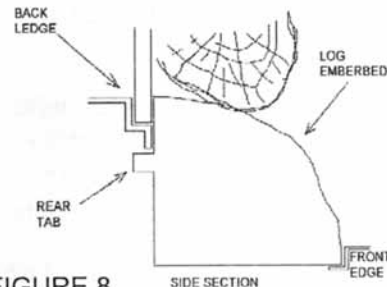
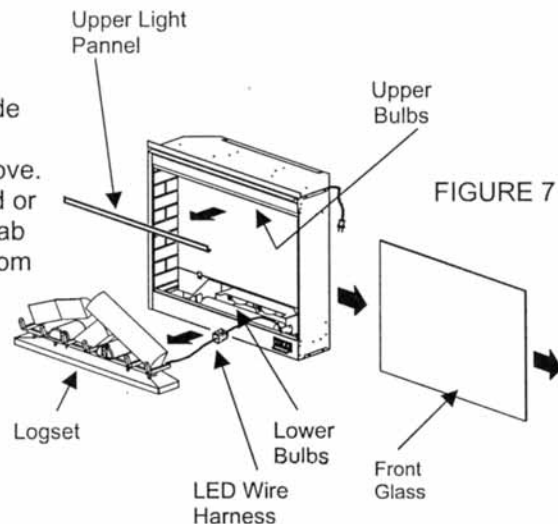

UPPER LIGHT BULB REQUIREMENTS

Quantity of 2 clear chandelier or candelabra bulbs with an E-12 (small) socket base, 25 watt rating.

DO NOT EXCEED 25 WATTS PER BULB

To access the upper light bulb area:

Figure 7

1. Slide fireplace out of mantel 2-3 inches.
2. Remove 4 Phillips screws from right side of trim.
3. Remove trim.
4. Slide glass to the right side of the fireplace to remove.
5. Remove upper light panel.
6. Upper bulbs located in the upper left and upper right corners of fireplace.
7. Unscrew bulbs counter clockwise. Insert new bulbs.
8. Re-install upper light bracket. Slide front glass back into position and attach trim.

TRAVIS ELECTRIC FIREPLACES

36 E FIREPLACE AIR FILTER

PURIFIRE™ FILTER

The Purifire™ filter supplied in your fireplace is reusable and washable. The filter should be cleaned or replaced on average once a year. To clean the filter gently tap filter on a hard surface to dislodge any loose dirt or debris, and then clean with water. No soap or cleaning products are recommended. The filter size is 20" X 10" X 1" rated at MERV 10. If using an after market filter follow the manufacturers recommended replacement instructions.

To replace filter:

1. Remove fireplace from mantel.
2. Filter can be accessed from the top rear of the unit.
3. Grasp filter and slide filter straight up.
4. Replace or clean filter.

NOTE

If after market air filter is used ensure it is installed according to the manufacturers recommended instructions.

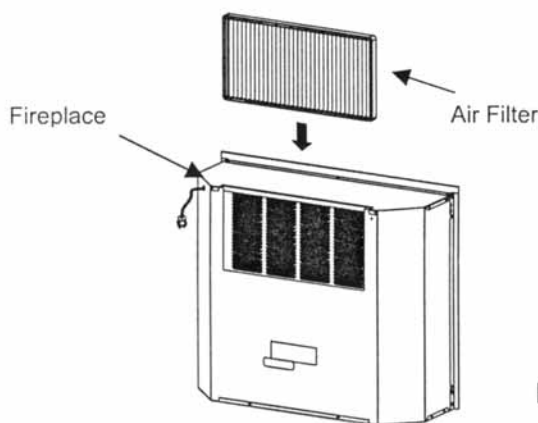

FIGURE 9

GLASS CLEANING

The glass is cleaned in the factory during the assembly operation. During shipment, installation, handling, etc., the glass may collect dust particles, these can be removed by dusting lightly with a clean dry cloth.

To remove fingerprints or other marks, the glass can be cleaned with a damp cloth. To prevent scratching, do not use abrasive cleaners or spray liquids on the glass surface.

FIREPLACE SURFACE CLEANING

Use a cloth dampened with warm water only to clean painted surfaces of the electric fireplace. Do not use abrasive cleaners.

TRAVIS INDUSTRIES PELLET PRODUCTS



Pellet Stoves & Inserts

Pellet Venting

Pellet Restrictors

Pellet Maintenance

Wood & Pellet Installation

Wood & Pellet Lab Activities

Installation Lab Activities

TRAVIS INDUSTRIES PELLET PRODUCTS

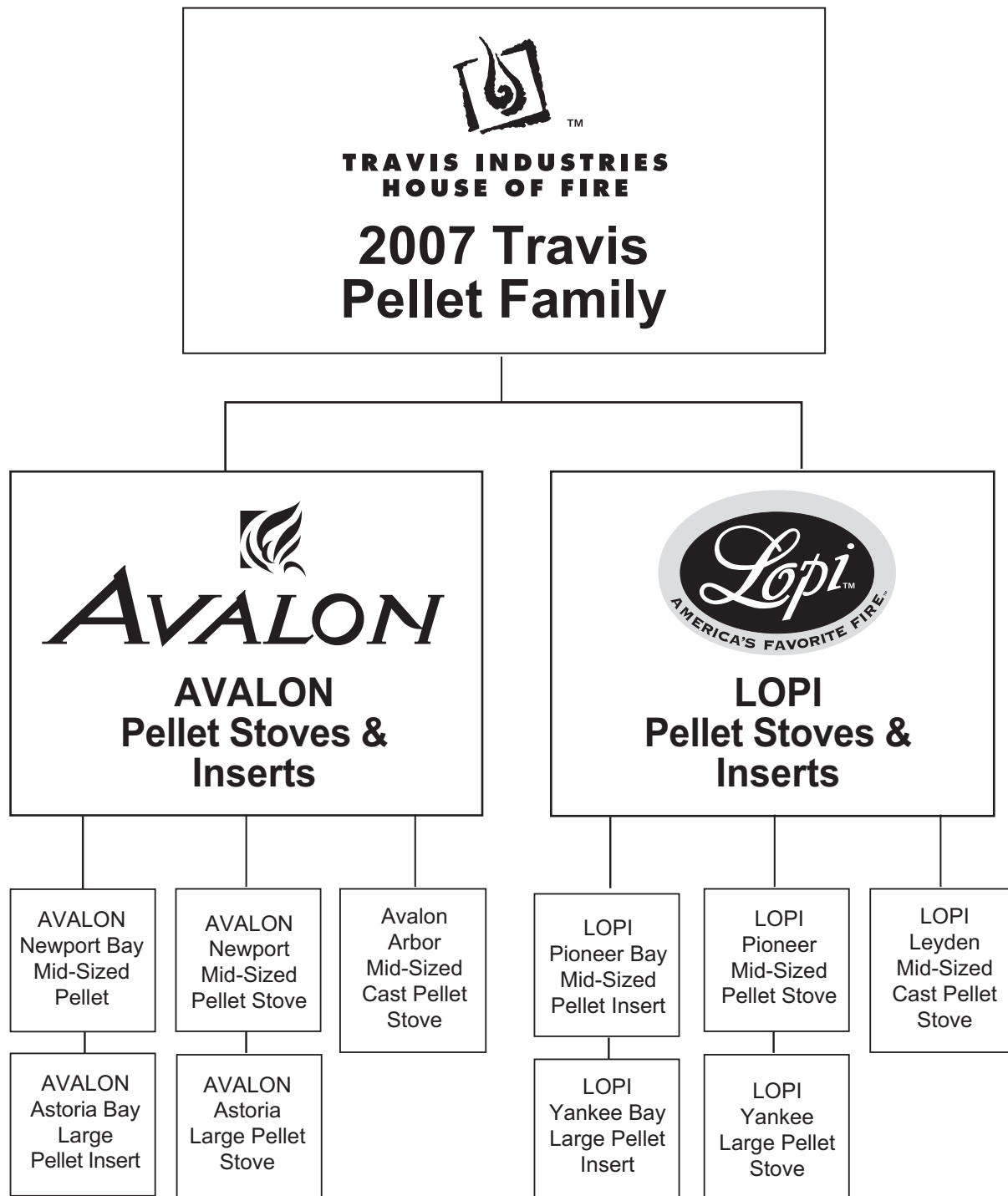

TRAVIS INDUSTRIES PELLET PRODUCTS



TRAVIS INDUSTRIES
HOUSE OF FIRE

AVALON Pellet Stoves & Inserts

Pellet Appliance	Square Feet Heating Space	Burn Rate	BTU's Range	Burn Time	Efficiency	Electrical Usage	Automatic Igniter	Hopper Capacity	Installation Approvals	Venting Size
NEWPORT BAY	800 - 1,600 Sq. Ft	High 3.5 Lbs./Hr. Low 1.2 Lbs./Hr.	Low 9,600 High 28,000	Low 29 Hours High 10 Hours	Up to 82%	400 W - Start Up 180 W - Operation 3.6 AMPS	YES 1,500° F	35 Lbs.	Horizontal & Vertical Class A Retro Masonry ZC Mobile Home	3" 4" at High Elevations or Tall Vertical Terminations
NEWPORT	800 - 1,600 Sq. Ft	High 3.5 Lbs./Hr. Low 1.2 Lbs./Hr.	Low 9,600 High 28,000	Low 50 Hours High 15 Hours	Up to 82%	400 W - Start Up 180 W - Operation 3.6 AMPS	YES 1,500° F	55 Lbs.	Horizontal & Vertical Class A Retro Mobile Home	3" 4" at High Elevations or Tall Vertical Terminations
ASTORIA	800 - 2,250 Sq. Ft	High 5.5 Lbs./Hr. Low 1.7 Lbs./Hr.	Low 13,940 High 45,100	Low 67 Hours High 21 Hours	Up to 82%	400 W - Start Up 180 W - Operation 3.6 AMPS	YES 1,500° F	115 Lbs.	Horizontal & Vertical Class A Retro Mobile Home	4"
ASTORIA BAY	800 - 2,250 Sq. Ft	High 5.5 Lbs./Hr. Low 1.7 Lbs./Hr.	Low 13,940 High 45,100	Low 32 Hours High 10 Hours	Up to 82%	400 W - Start Up 180 W - Operation 3.6 AMPS	YES 1,500° F	55 Lbs.	Horizontal & Vertical Class A Retro Mobile Home	4"
ARBOR	800 - 2,250 Sq. Ft	High 5.5 Lbs./Hr. Low 1.7 Lbs./Hr.	Low 13,940 High 45,100	Low 47 Hours High 15 Hours	Up to 82%	400 W - Start Up 180 W - Operation 3.6 AMPS	YES 1,500° F	47 Lbs.	Horizontal & Vertical Class A Retro Mobile Home	4"

TRAVIS INDUSTRIES PELLET PRODUCTS



TRAVIS INDUSTRIES
HOUSE OF FIRE

AVALON Pellet Stoves & Inserts

Model	Glass Viewing Area	Heat Exchanger Tubes	Restrictor	Manual Operation	Wall Thermostat Operation	Remote Operation	Convection Blower	Exhaust Blower	3/16" 309 Stainless Steel Burn Pot	Options
NEWPORT BAY	167 Sq. In.	6	Intake Air	YES	YES Optional	YES	Cross Flow Transaxial 130 CFM	Centrifugal 75 CFM	YES	Gold or Nickel Door, Gold Convection Grill, Log Set
NEWPORT	167 Sq. In.	6	Intake Air	YES	YES Optional	YES	Cross Flow Transaxial 130 CFM	Centrifugal 75 CFM	YES	Gold or Nickel Door, Gold Convection Grill, Log Set
ASTORIA	321 Sq. In.	10	Intake Air & Exhaust	YES	YES Standard with Astoria	YES	Centrifugal 165 CFM	Centrifugal 92 CFM	YES Curved Bottom Wide Flame Dispersal	Gold or Nickel Door & Convection Grill, Universal Log with Modified Holder
ASTORIA Bay	321 Sq. In.	12	Intake Air & Exhaust	YES	YES Standard with Astoria	YES	Centrifugal 165 CFM	Centrifugal 92 CFM	YES Curved Bottom Wide Flame Dispersal	Gold or Nickel Door & Convection Grill, Universal Log with Modified Holder
ARBOR	308 Sq. In.	12	Intake Air and Exhaust	YES	YES Standard	YES	Centrifugal 165 CFM	Centrifugal 92 CFM	YES Curved Bottom for Wide Flame Dispersal	Universal Log with Modified Holder

TRAVIS INDUSTRIES PELLET PRODUCTS



TRAVIS INDUSTRIES
HOUSE OF FIRE

Pellet Stoves & Inserts



Pellet Appliance	Square Feet Heating Space	Burn Rate	BTU's Range	Burn Time	Efficiency	Electrical Usage	Automatic Igniter	Approved Fuel	Hopper Capacity	Installation Approvals	Venting Size
PIONEER BAY	800 - 1,600 Sq. Ft	High 3.5 Lbs./Hr. Low 1.2 Lbs./Hr.	Low 9,600 High 28,000	Low 29 Hours High 10 Hours	Up to 82%	400 W - Start Up 180 W - Operation 3.6 AMPS	YES 1,500° F	Wood Pellets	35 Lbs.	Horizontal & Vertical Class A Retro Masonry ZC Mobile Home	3" 4" at High Elevations or Tall Vertical Terminations
PIONEER	800 - 1,600 Sq. Ft	High 3.5 Lbs./Hr. Low 1.2 Lbs./Hr.	Low 9,600 High 28,000	Low 50 Hours High 15 Hours	Up to 82%	400 W - Start Up 180 W - Operation 3.6 AMPS	YES 1,500° F	Wood Pellets	55 Lbs.	Horizontal & Vertical Class A Retro Mobile Home	3" 4" at High Elevations or Tall Vertical Terminations
YANKEE	800 - 2,250 Sq. Ft	High 5.5 Lbs./Hr. Low 1.7 Lbs./Hr.	Low 13,940 High 45,100	Low 47 Hours High 15 Hours	Up to 82%	400 W - Start Up 180 W - Operation 3.6 AMPS	YES 1,500° F	Wood Pellets	80 Lbs.	Horizontal & Vertical Class A Retro Mobile Home	4"
YANKEE BAY	800 - 2,250 Sq. Ft	High 5.5 Lbs./Hr. Low 1.7 Lbs./Hr.	Low 13,940 High 45,100	Low 32 Hours High 10 Hours	Up to 82%	400 W - Start Up 180 W - Operation 3.6 AMPS	YES 1,500° F	Wood Pellets	55 Lbs.	Horizontal & Vertical Class A Retro Mobile Home	4"
LEYDEN	800 - 2,250 Sq. Ft	High 5.5 Lbs./Hr. Low 1.7 Lbs./Hr.	Low 13,940 High 45,100	Low 47 Hours High 15 Hours	Up to 82%	400 W - Start Up 180 W - Operation 3.6 AMPS	YES 1,500° F	Wood Pellets or 50/50 Mix Wood and Corn	47 Lbs.	Horizontal & Vertical Class A Retro Mobile Home	4"

TRAVIS INDUSTRIES PELLET PRODUCTS



TRAVIS INDUSTRIES
HOUSE OF FIRE

Pellet Stoves & Inserts



Pellet Appliance	Glass Viewing Area	Heat Exchanger Tubes	Restrictor	Manual Operation	Wall Thermostat Operation	Remote Control Operation	Convection Blower	Exhaust Blower	3/16" 309 Stainless Steel Burn pot	Options
PIONEER BAY	167 Sq. In.	6	Intake Air	YES	YES Optional	YES	Crossflow Transaxial 130 CFM	Centrifugal 75 CFM	YES	Gold or Pewter Door & Convection Grill, Universal Log with Modified Holder
PIONEER	167 Sq. In.	6	Intake Air	YES	YES Optional	YES	Crossflow Transaxial 130 CFM	Centrifugal 75 CFM	YES	Gold or Pewter Door & Convection Grill, Universal Log with Modified Holder
YANKEE	252 Sq. In.	12	Intake Air and Exhaust	YES	YES Standard	YES	Centrifugal 165 CFM	Centrifugal 92 CFM	YES Curved Bottom for Wide Flame Dispersal	Gold or Pewter Door & Convection Grill, Universal Log with Modified Holder
YANKEE BAY	252 Sq. In.	10	Intake Air and Exhaust	YES	YES Standard	YES	Centrifugal 165 CFM	Centrifugal 92 CFM	YES Curved Bottom for Wide Flame Dispersal	Gold or Pewter Door & Convection Grill, Universal Log with Modified Holder
LEYDEN	308 Sq. In.	12	Intake Air and Exhaust	YES	YES Standard	YES	Centrifugal 165 CFM	Centrifugal 92 CFM	YES Curved Bottom for Wide Flame Dispersal	Universal Log with Modified Holder

Features of Travis Brand Pellet Stoves and Inserts

- Small and Large Heating Capacities
- 800 to 1,600 Sq. Ft. Heating Capacity
- Large Hopper Capacity
- Gravity Flow Feed
- Heavy-Duty Auger Shaft and Flight
- Removable Auger Cover
- Self-Lubricating Bronze Auger Bearings
- Heavy-Duty Auger Motor
- Heat Exchanger Ash Rake Cleaner
- No Tools Requires for Cleaning
- 3/16" Stainless Steel Firepot
- Cast Iron Fireback
- Air Tight Door Seal
- Airwash Keeps Glass Clear
- Options of Black, Gold Door & Nickel Door - Avalon
Pewter Door - Lopi
- Operation Instructions on Inside of Lid
- "Real World" Seven Year Warranty
- Horizontal or Vertical Termination Flue Options
- Outside Air kit
- Minimal Clearances to Combustibles
- Minimal Floor Protection Requirements
- Easy Access Components
- Fuse Protected Systems
- Inserts Masonry and ZC Approved
- Adjustable Door
- Spring Loaded Rails on Ash Dump
- Hopper Safety Snap Disc
- Flow Safety Snap Disk
- Quiet Operation
- Automatic ignition
- Thermostat/Remote Control Option
- Auto or Manual Operation Option
- Single Control Feed/Air Control

TRAVIS INDUSTRIES PELLET PRODUCTS



Features of Avalon Arbor Cast Iron Pellet Stove



Features:

- Medium-size pellet stove.
- Black painted cast iron design of the wood burning Leyden
- Organic tree cast iron detail.
- Cast double doors with large fireview.
- Ash Glide Ash Pan:
 - Most convenient ash removal system on the market, no special tool needed.
 - Large ash holding capacity.
- Uses a 4" chimney.
- EPA Exempt.
- Uses same pellet components found in the Yankee pellet stove.
- Will have same performance statistics as the Astoria.
- 47 lbs. hopper.
- Unique burn pot designed to burn wood pellets or a 50/50 mix of wood pellets and corn.
- Most efficient heat exchange system of any Avalon pellet stove.
- Self-starting ignitor standard.
- Whisper quiet performance - variable combustion fan synchronized with adjustable burn rate.
- Wall thermostat standard.
- Stay clean airwash.
- Stainless-steel burn pot removes easily for cleaning.
- Electronic control board for manual or automatic operation with use of low voltage thermostat or programmable wall thermostat or remote control.

Features of LOPI Leyden Cast Iron Pellet Stove



Features:

- Medium-size pellet stove.
- Black painted cast iron design of the wood burning Leyden
- Early-American architectural cast iron detail.
- Cast double doors with large fireview.
- Ash Glide Ash Pan:
 - Most convenient ash removal system on the market, no special tool needed.
 - Large ash holding capacity.
- Uses a 4" chimney.
- EPA Exempt.
- Uses same pellet components found in the Yankee pellet stove.
- Will have same performance statistics as the Yankee.
- 47 lbs. hopper.
- Unique burn pot designed to burn wood pellets or a 50/50 mix of wood pellets and corn.
- Most efficient heat exchange system of any Lopi pellet stove.
- Self-starting ignitor standard.
- Whisper quiet performance - variable combustion fan synchronized with adjustable burn rate.
- Wall thermostat standard.
- Stay clean airwash.
- Stainless-steel burn pot removes easily for cleaning.
- Electronic control board for manual or automatic operation with use of low voltage thermostat or programmable wall thermostat or remote control.

Pellet Appliance Components

When designing pellet appliances the following considerations need to take place.

Safety - The appliance must be designed to contain fire and keep the fuel in the pellet hopper from catching on fire.

Efficiency - Today's heating costs push the public to demand efficient economical appliance operation.

Styling - Appliance appearance and customer choice are an important consideration of the appliance purchase.

Quality - Today's consumer expects top quality for many years of operation.

Easy to operate - Consumers want simple easy-to-operate (consumer friendly) appliances.

Easy to service and maintain - Consumers and service people demand simple easy serviceability.

Quiet operation - A pellet appliance has the potential of being very noisy. Two blowers, auger motor, auger flight and dropping pellets can be very distracting. Therefore, dampening vibration devices have to be incorporated into the appliance design.

Pellet Appliance Components

- Pellet Hopper
 - Angled to ensure non-bridging gravity feed
 - Aluminized steel construction
 - Large capacities



- Auger
 - 3/4" steel shaft
 - 1 1/4" pitch spacing (small stoves)
 - 2" pitch spacing (large stoves)
 - Easy, removable access cover
 - Sintered bronze bearings



- Auger Motor
 - Merkl Korff motor
 - Turns at 1 RPM
 - Impedance protected to prevent burnout if the auger freezes up
 - Rubber stops for quiet operation

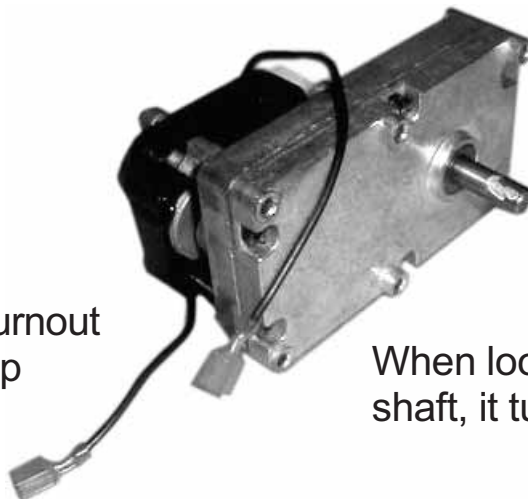

When looking at output shaft, it turns clockwise

Pellet Appliance Components

• Control Board

- Remote, automatic, and manual selection
- Remote and thermostat ready
- Single control air/feed rate
- LED panel display
- Fuse protected



• Flow Switch

- Senses vacuum from exhaust blower
- N.O. switch
- Wires in series with the auger circuit



• Snap Disk



Hopper Snap Disk

- Set point 200° F
- N.C. switch
- Large stove uses (2)
- Wires in series with auger circuit



System Snap Disk

- Senses heat (pellets are burning)
- Large stove - mounted on exhaust blower
- Small stove mounted on horizontal exhaust port
- Set point 120° F
- N.O. switch
- Large stove uses (2)

Pellet Appliance Components

• Convection Blower



Small Pellet Stoves

- 130 CFM
- Cross flow transaxial blower
- Cushion mounting vibration control



Large Pellet Stoves

- 165 CFM
- Centrifugal blower
- Cushion mounting for vibration control

• Exhaust Blower

Small Pellet Stoves

- 75 CFM
- Centrifugal blower
- Cushion mounting for vibration control

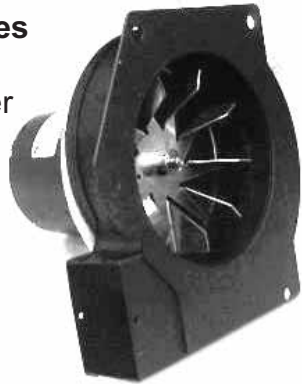

Large Pellet Stoves

- 92 CFM
- Centrifugal blower
- Cushion mounting for vibration control

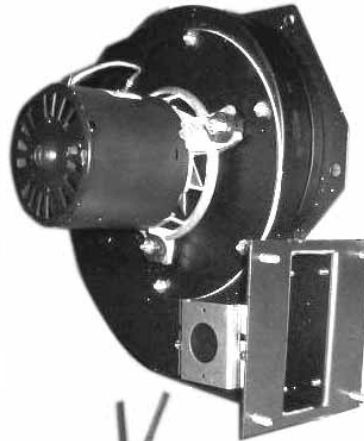

• Igniter

- 110 volt
- Heats to 1500° F
- Sheath on large stoves 1/2" longer



Pellet Appliance Components

• Log Set

- Optional universal cast log
- Large stoves use a modified holder

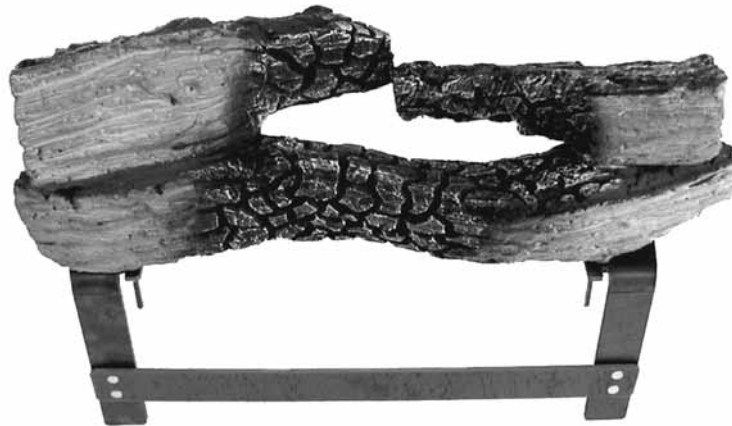

• Burn Pot

- Stainless steel burn pot
- Bottom 3/16" - Type 309 Stainless Steel
- Large burn pot features arched bottom
- Easily removed for maintenance
- One way fit up



Small Pellet Stoves



**Large Pellet Stoves
& Cast Iron Stoves
Multi-Fuel Burn Pot**

Configuring the Control Board

Overview

The new AVR control board is the next generation control board that is compatible with all pellet stoves and inserts, large and small manufactured from 1997 to today. Circuitry on the board allows it to be programmed for either the large or small pellet heaters (these heaters use different voltage settings). See “” for details. It also includes a diagnostic feature that allows a service person to diagnose a fault without having to inspect the wiring or components. The indicator lights on the control board will display a fault code after a fault has been detected. This allows the service person to determine which component caused the fault. See “Diagnostic Codes” for details. NOTE: the new wiring harness (250-00017) is required to utilize this feature.

Configuring for Large or Small Heaters

The control board is initially configured for the large heaters (Astoria and Yankee models). To change the configuration the control board must be in the off position plugged into a cold stove, (no lights or running components) with the jumper molex removed (see the illustration below). In this condition press and hold the manual auger button down and press both fan up and fan down arrow keys at the same time. All heat output lights will flash. One flash denotes the large pellet heater configuration. Two flashes denote the small pellet heater configuration (Newport and Pioneer models). Repeat pressing the keys until the correct configuration is obtained.

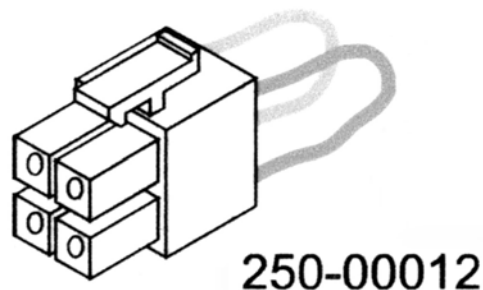

Configuring the Control Board

Using this Control Board with Older Wiring Harnesses

When the control board is installed on an older wire harness the 4 pin molex jumper plug on the back of the control board next to the stock wire harness must be installed. This jumper replaces the diagnostic wires (see “”) that are present on the new wiring harness. The control board will work normally, but the diagnostic capabilities will not function.

Technical Notes for Operation

The new pellet control board is essentially the same as our old board. The biggest difference between them is that buttons were used in place of knobs on the heat and fan controls.

Make sure to give the home owner the “Pellet Heater Operating Instructions” if you are replacing an older board (the final 4 pages of this instruction sheet). It contains the new operating instructions for this control board.

A few changes were made to accommodate the new control board. The start up cycle indicator on the old board illuminates all heat output indicator lights to show the unit is in a start-up cycle and adjusting the heat setting knob would not change them. On the new board to enable adjusting the run settings during start-up we made the start-up indicator the blinking #1 heat output light. If the #1 heat output light is blinking the board is in a start-up mode and the blower and auger outputs can not be adjusted. The run settings the unit will go to after start-up are displayed on the heat output indicator. These settings can be adjusted any time during start up by pushing the up or down heat buttons on the panel. When the fan setting is adjusted up or down the heat output indicators will turn off and the fan setting will display.

Another feature we added to the control board is a manual auger feed. This button can be used to prime and empty the auger or speed the initial delivery of pellets to the burn pot. All start-up timing remains the same and the stove will still self prime the auger tube – this option allows the operator an additional option. It is not needed for normal operation.

All voltage outputs and feed rates remain the same as the old board. There is a difference in respect to the auger on/off times. The auger timing was changed to shorten the interval between pellet drops to the burn pot. For example, on low the auger used to turn for 3 seconds and remain off for 13 seconds, for this same condition this control board turns the auger for 2.5 seconds and remains off for 10.7 seconds. This produces the same amount of time the auger is turning and not turning but gives a steadier flame height and less incidental outages on low.

Configuring the Control Board

Diagnostic Codes (Qualified Service Personnel Only)

- Fault and #2 (LOW) Light Flash = Flow Switch Fault
- Fault and # 4 (MED) Light Flash = System Snap Disk Fault (pellets run out & stove goes cold)
- Fault and # 6 (HIGH) Light Flash = Safety or Hopper Snap Disk Fault

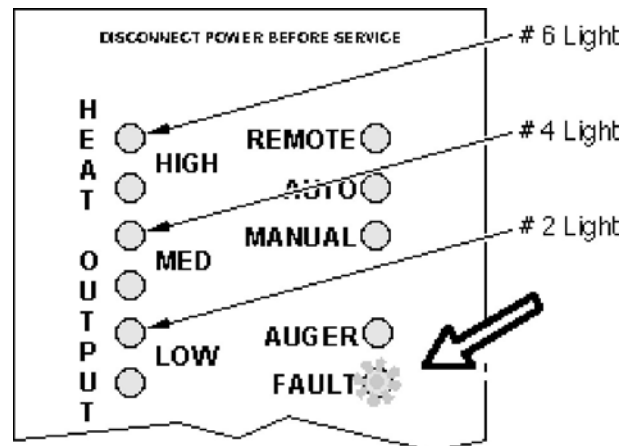

Flow Switch Fault

Fault light and #2 heat indicator blinking.

This fault code indicates pressure/flow switch opened or broke its electrical connection during operation.

Likely causes:

- Pinched, cracked or broken pressure tubing.
- Plugged tubing nipple on blower housing.
- Heavy ash build up in the exhaust fan housing,
- Faulty wiring, bad or broken connection of flow switch gray wires.
- Weak or bad combustion blower
- Faulty pressure switch.

Configuring the Control Board

Diagnostic Codes (Qualified Service Personnel Only) - Continued

System Snap Disk Fault

Fault light and #4 heat indicator blinking.

This fault code is caused by a heat sensitive switch that tells the control board if the appliance is hot or cold. During operation if the unit runs out of pellets or loses its fire this switch will communicate to the control board that the stove is getting cold. The control board will shut off the auger functions and initiate a twenty minute combustion fan safety cool down. Another condition that will trigger this fault code is a failed start. When the appliance is started the control board initiates a 30 minute timer, if the appliance is cold at the end of this 30 minute start up timer the control board will indicate a #4 fault and initiate a 20 minute combustion fan cool down.

Likely causes:

- Unit ran out of pellets.
- Fire went out during operation.
- Unit was cold at the end of a start cycle (fire did not light).
- Faulty snap disk.

Configuring the Control Board

Diagnostic Codes (Qualified Service Personnel Only) - Continued

Safety or Hopper Snap Disk Fault

Fault light and #6 heat indicator blinking.

This fault code is caused by the safety or hopper snap disk registering an over-heated appliance during operation. The control board then shuts down the auger and the convection and combustion blower will run at maximum output for a 40 minute safety cool down cycle. The only way to stop this cool down is to unplug the appliance to reset the control board.

Likely causes:

- Faulty snap disk
- Corroded, loose or broken Snap Disk wiring.
- Failed, plugged or blocked convection blower.
- Reduced air flow into the motor compartment such as blocked air vents on panels or doors.
- Missing refractory.
- Improper fuel type.
- Unauthorized parts used in the pellet feed system.

Wiring Diagram (New, 2005 Version - 250-00017)

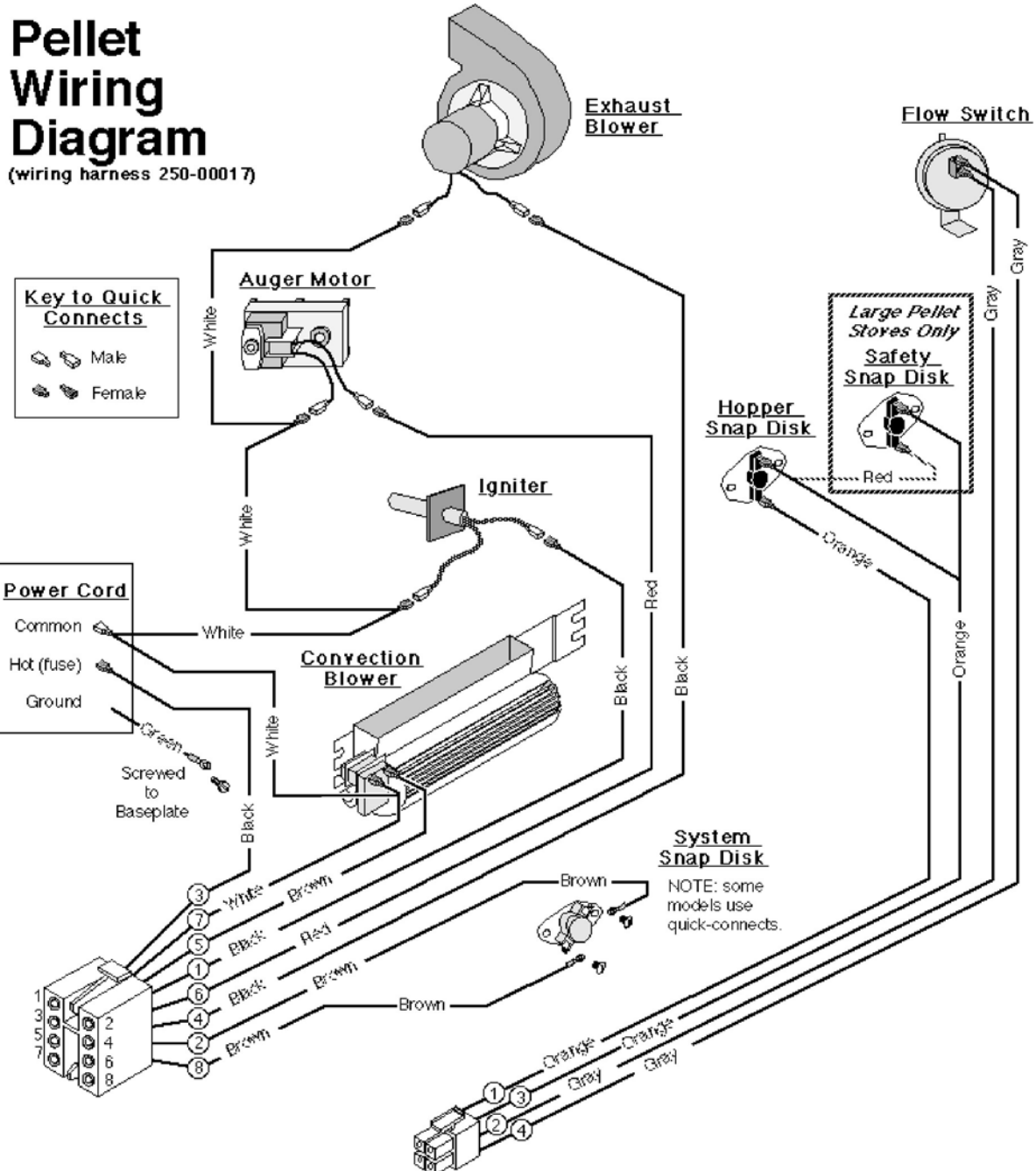

Wiring Diagram (Old Version - 100-00393B)

NOTE: Wire coloring may not be identical to this diagram

Pellet Wiring Diagram

(wiring harness 100-00393B)

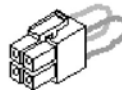
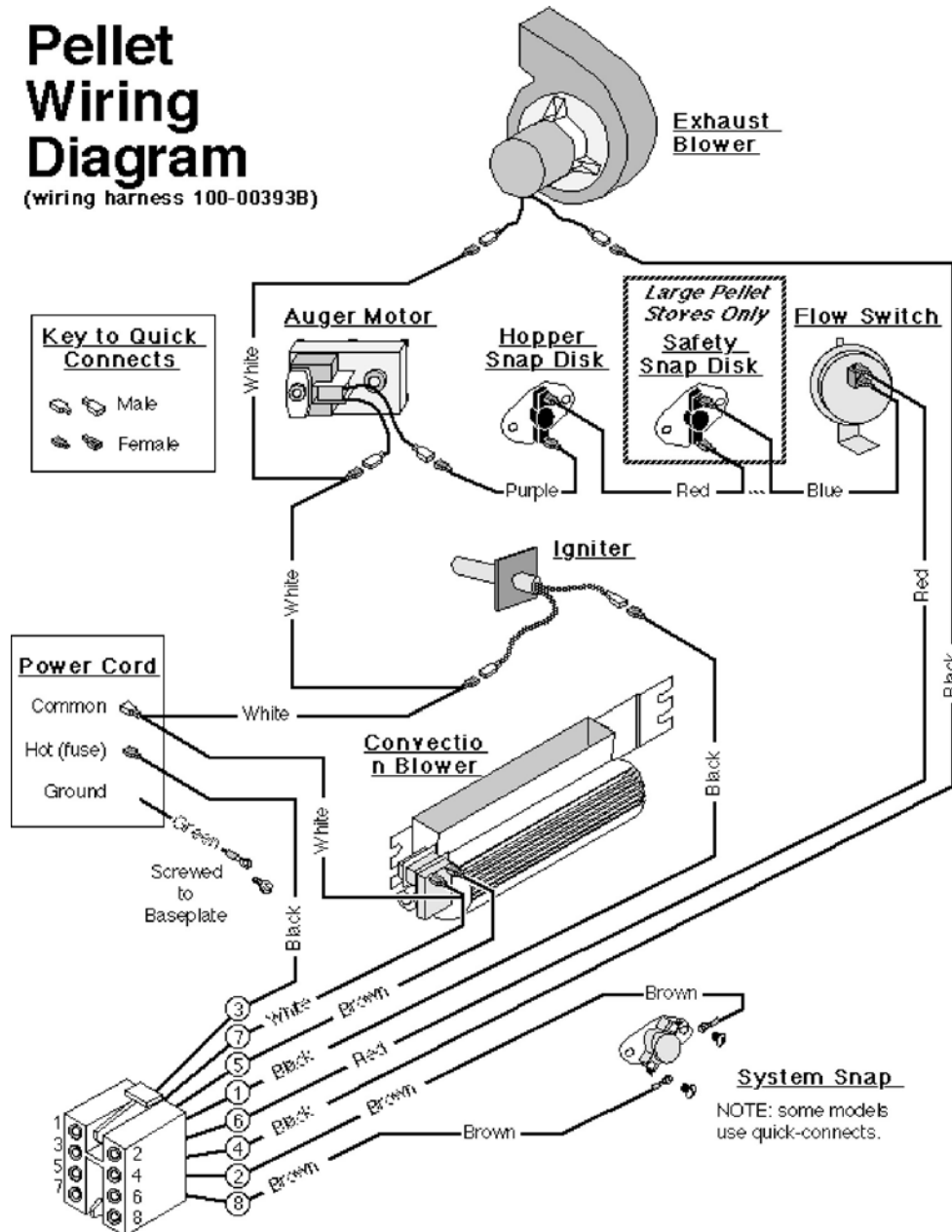

NOTE: Make sure the jumper plug is installed when using the AVR control board with this wiring harness.

Control Board Operation

The Two Modes of Operation:

Manual

Manual mode requires the user to turn the heater on and off manually.

Auto (requires a thermostat)

Auto mode allows you to use a thermostat to control room temperature. The stove automatically turns on when the temperature drops below the thermostat setting. Once the stove reaches operating temperature, the stove then runs at the heat output setting selected.

Switching

Modes While in Operation

Whenever the stove is switched from one mode to another while in operation, the stove will enter the "start-up" sequence for a minimum of 20 minutes.

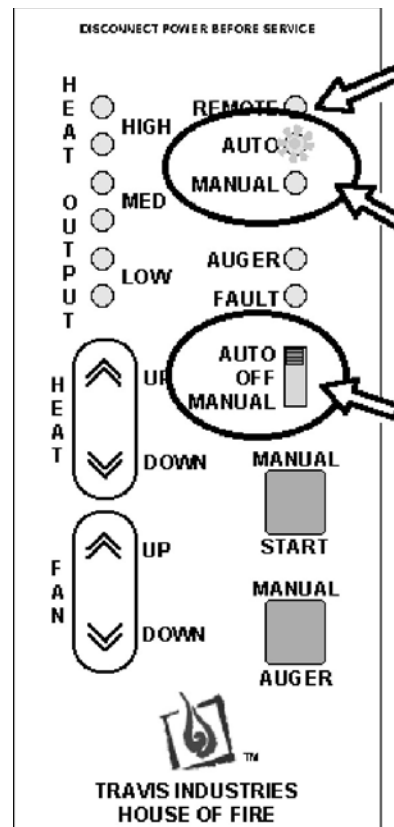

NOTE: If using a modulating remote, this light will come on to indicate the remote is controlling the heater.

These indicator lights are used to determine which mode you are in.

Use the mode switch to determine the mode.

Control Board Operation

Manual Mode

Manual mode requires the user to turn the heater on and off manually.

To Start

Press the "Manual Start" button. That's it. The stove automatically goes to a medium burn rate and high fan while the igniter starts the fire burning within 10 minutes. During this period the lowest "HEAT OUTPUT" light will flash. If the stove does not start in 30 minutes, the stove turns off.

Once up to temperature, the stove will then run at the heat output setting selected on the control panel (see "To Adjust the Heat" below).

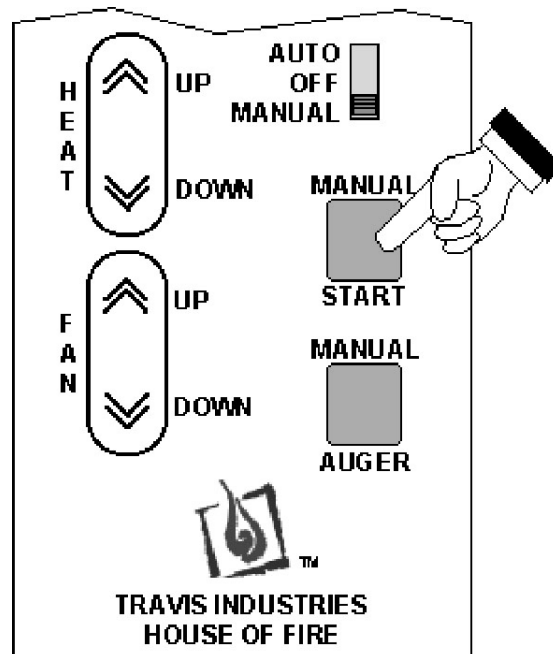

Control Board Operation

To Shut Down

Move the mode switch to "OFF". The exhaust blower will still run until the heater cools down.

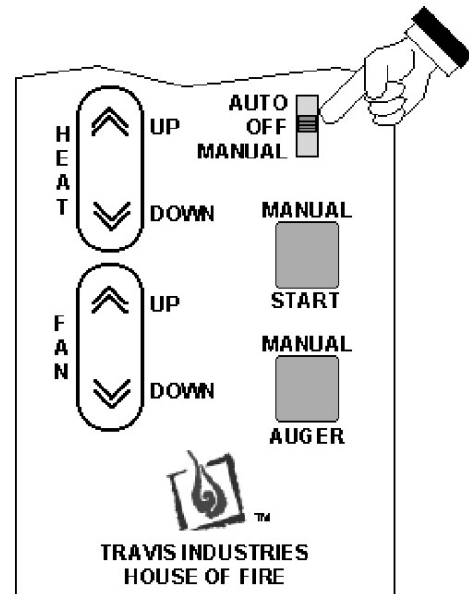

To Adjust the Heat

Press the "Heat" buttons to adjust the heat output.

NOTE: During start-up you may adjust the heat setting. This heat setting will take affect once the start-up sequence is complete.

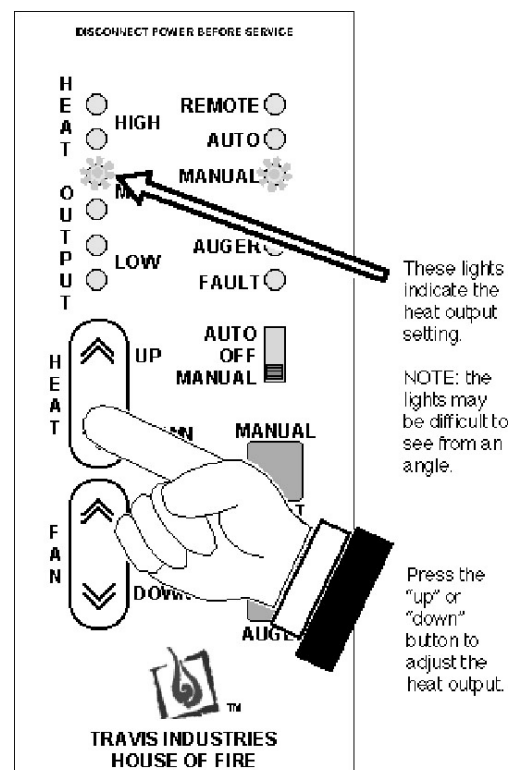

Control Board Operation

Auto Mode

Auto mode allows you to use a thermostat to control room temperature. The stove automatically turns on when the temperature drops below the thermostat setting. Once the stove reaches operating temperature, the stove then runs at the heat output setting selected.

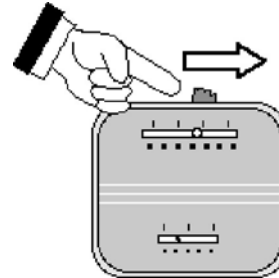

To Adjust Room Temperature (or Start the Stove)

Move the thermostat to the heat setting desired. If the room is cooler than the setting, the stove will go through the start-up sequence for approximately 10 minutes. During this period the lowest "HEAT OUTPUT" light will flash. Once up to temperature, the stove will then run at the heat output setting selected on the control panel. If the room is too hot, move the thermostat to a lesser setting.

To Adjust the Heat

Press the "Heat" buttons to adjust the heat output.

HINT:

If you find that the stove turns on and off repeatedly, you may wish to turn the heat output to a lesser setting. The lower setting will provide a more consistent heat output over time, eliminating the need for the thermostat to repeatedly turn the stove off.

NOTE:

If the thermostat calls for heat while the stove is still cooling down, the stove will go through the start-up sequence (for a minimum of 20 minutes).

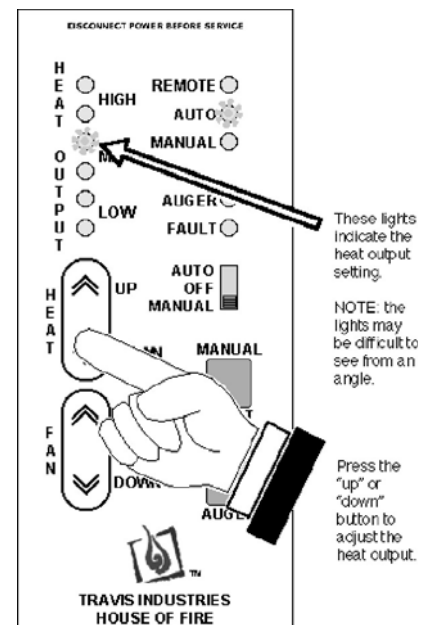

Control Board Operation

To Shut Down

Move the mode switch to "OFF". The exhaust blower will still run until the heater cools down.

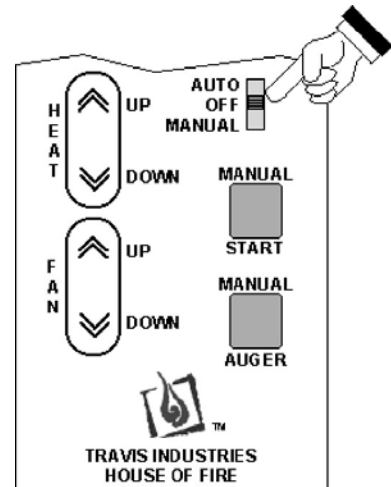

Adjusting the Fan Speed

NOTE: When you press the Fan speed buttons the "Heat Output" lights will indicate fan speed (not "Heat Output"). After a few seconds the "Heat Output" lights will go back to displaying the heat output setting.

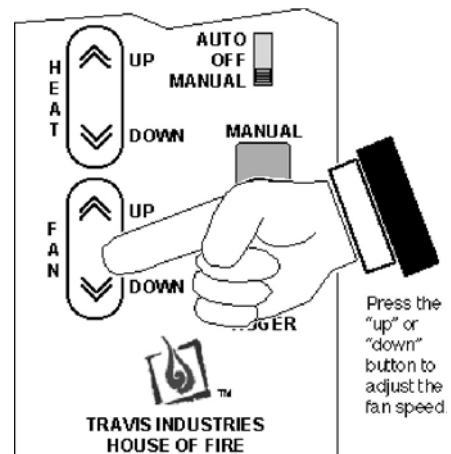

Control Board Operation

"FAULT" Light

This light comes on when an error occurs:

- The stove runs out of pellets
- During initial start-up (for a split second) or for improper electrical frequency
- A start-up sequence that does not result in the heater coming up to temperature
- To reset the fault light, turn the mode switch to off and re-start the stove.

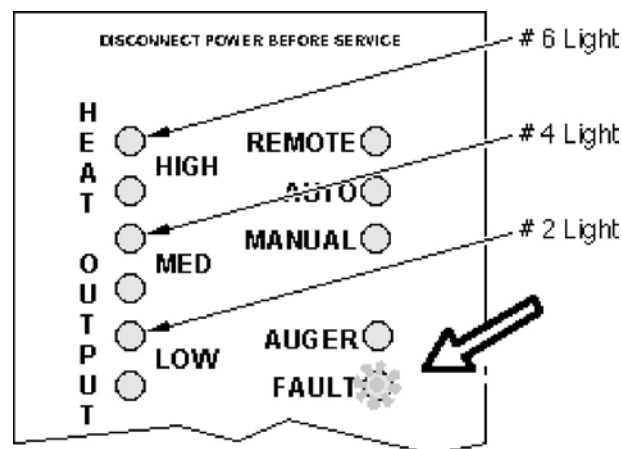

Pellet Appliance Operation Sequence

- Pellet appliance operation sequence is important to understand when servicing pellet appliances.
- Below are the steps our pellet appliances go through. The following page provides a detailed flow chart of what happens in each step.

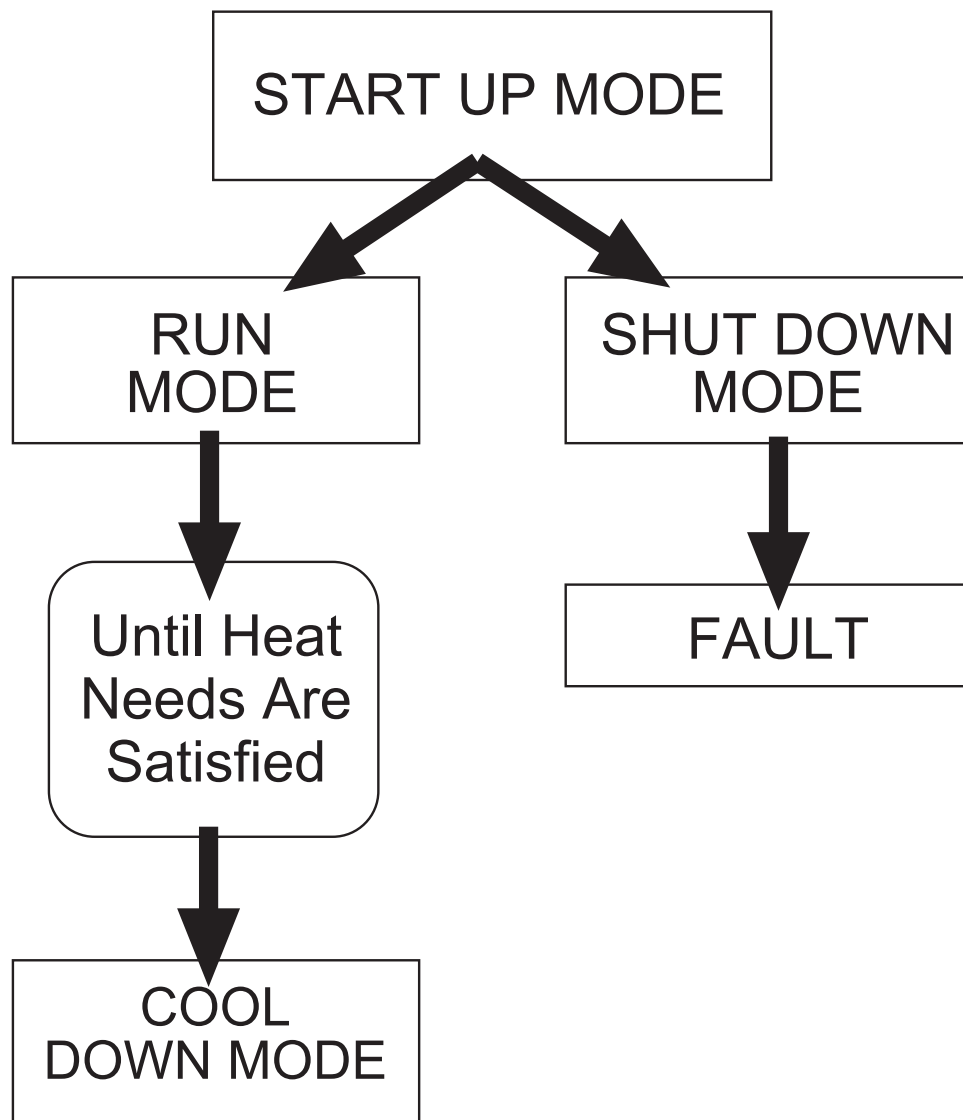

TRAVIS INDUSTRIES PELLET PRODUCTS

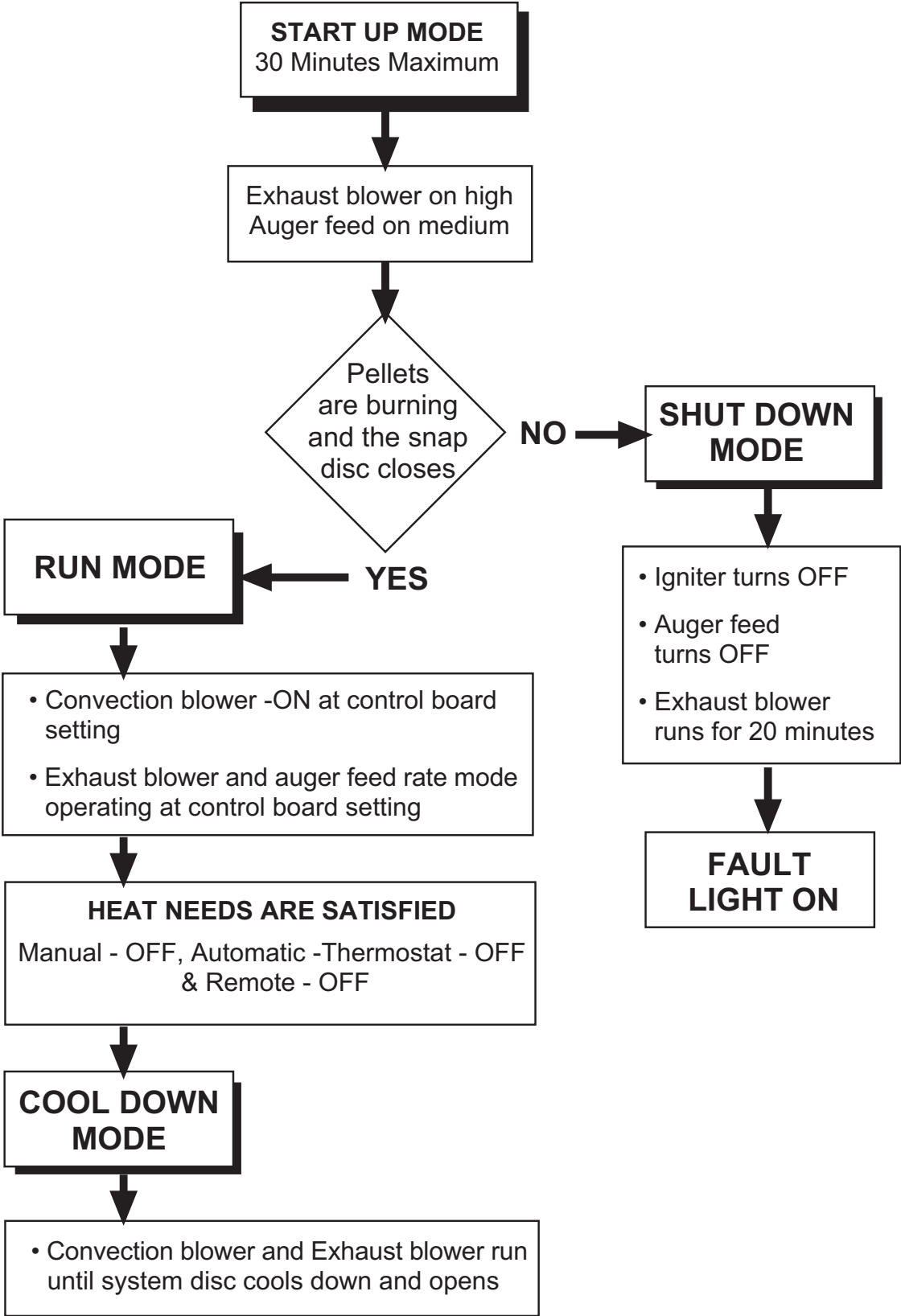

Power Outage

In manual operation or remote (but is not remote thermostat)

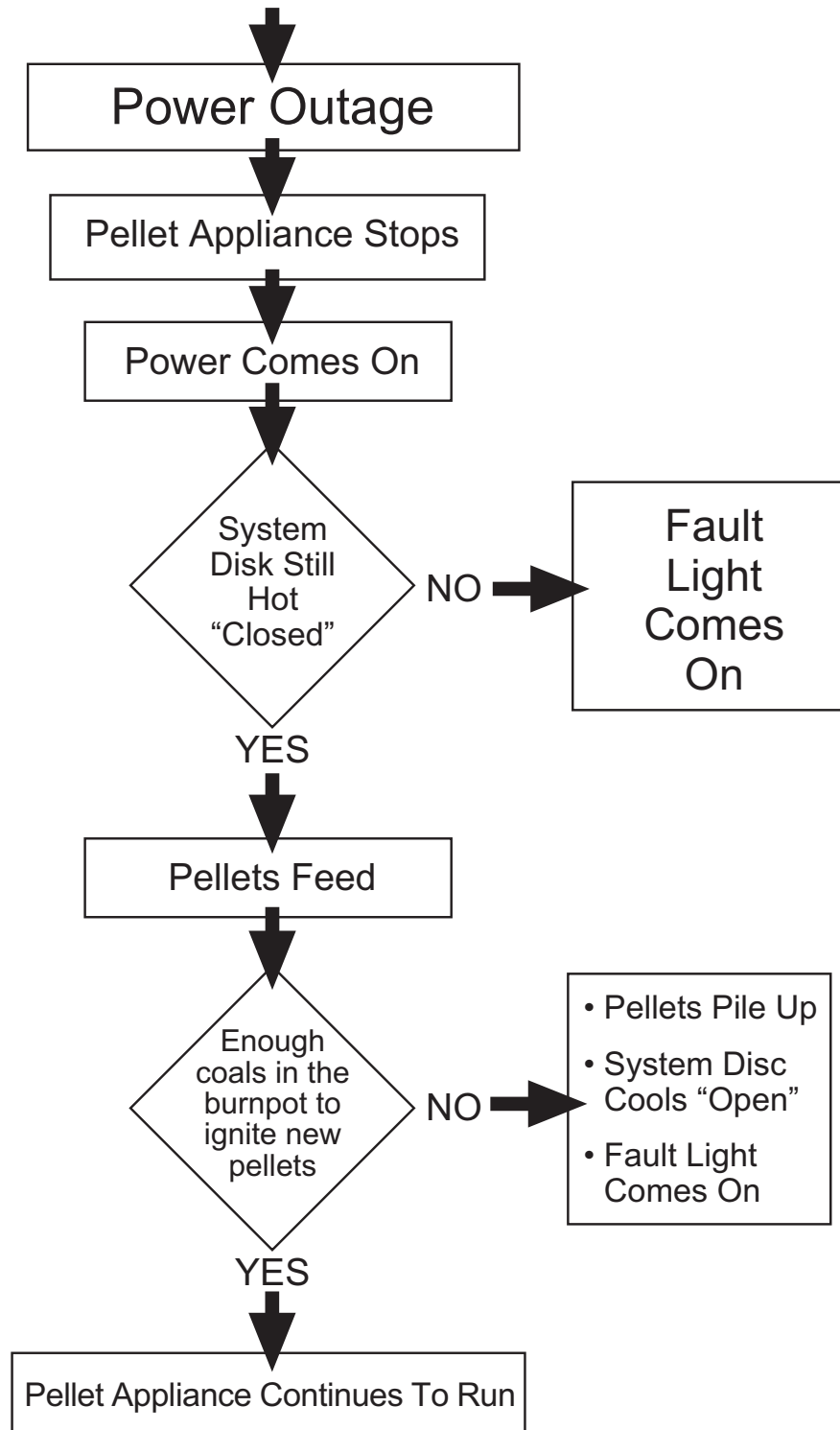

Power Outage

In automatic operation or remote thermostat (but is not remote thermostat)

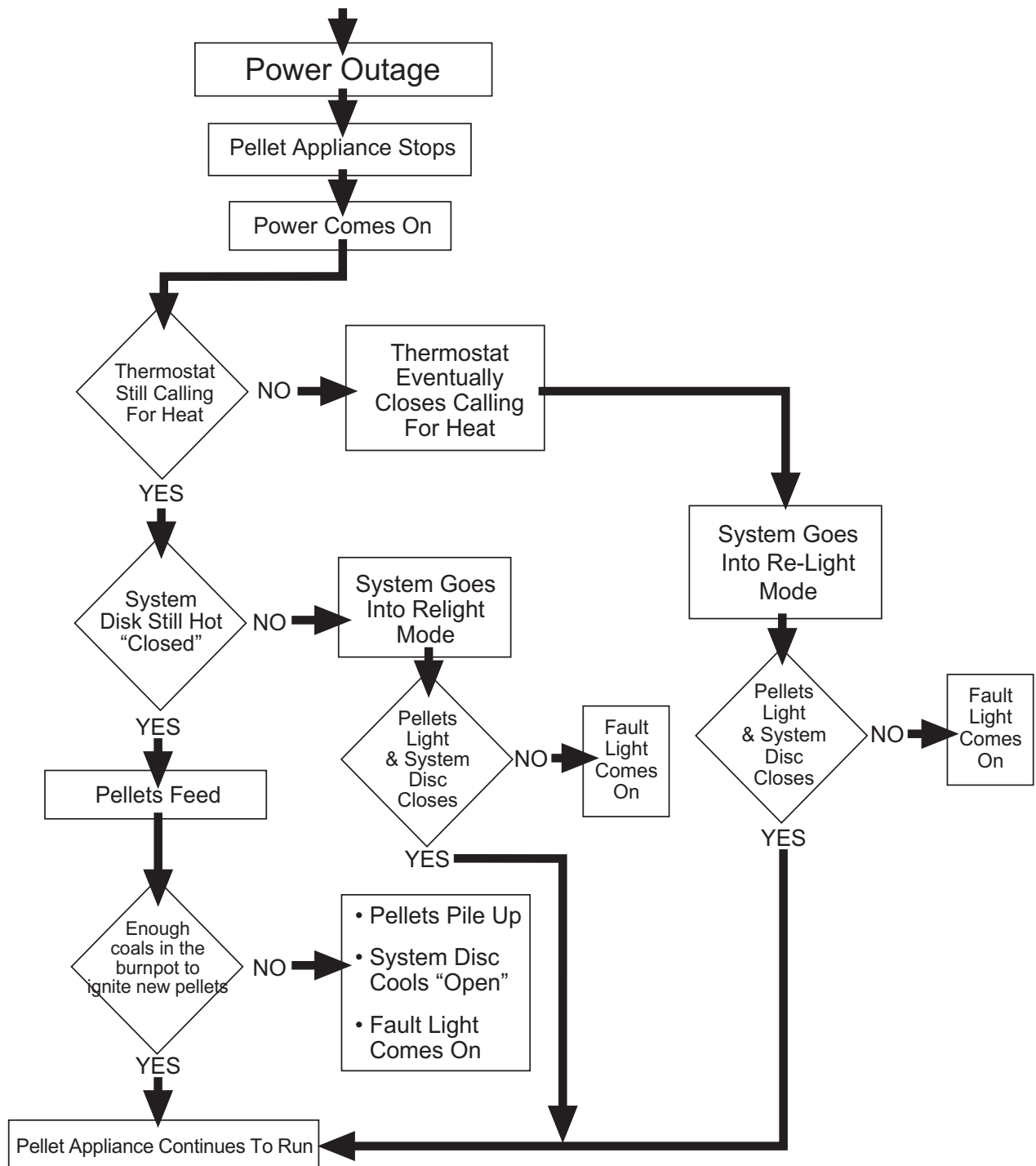



HIGH

**RED
LIGHT**

**3 Seconds ON
OFF 2 Seconds**



MED.

**YELLOW
LIGHT**

**3 Seconds ON
OFF 6 - 9 Seconds**

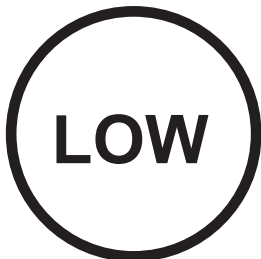



LOW

**GREEN
LIGHT**

**3 Seconds ON
OFF 12 - 15 Seconds**

TRAVIS INDUSTRIES PELLET PRODUCTS

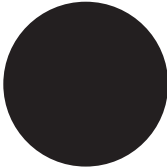

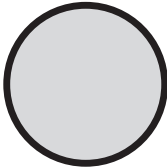
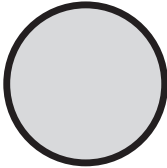
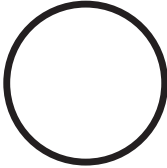
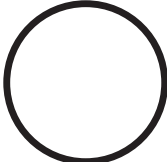
			<u>ON</u>	<u>OFF</u>
HIGH RED LIGHT		6	2.5	2.2
		5	2.5	2.9
MED. YELLOW LIGHT		4	2.5	3.8
		3	2.5	4.6
LOW GREEN LIGHT		2	2.5	7.5
		1	2.5	10.7

Thermostats & Remotes

- Thermostats and remotes make for convenient and automatic operation of the pellet appliance.
- Our large pellet stoves and inserts ship with a wall thermostat.
- A wall thermostat is the best automatic device for customers who desire a more constant room temperature comfort.
- Not all people are qualified to operate remotes, some will always have problems with their remote.
- Remote operation will not show an immediate fire change (like channel changing on a TV)
- Our modulating remote has 6 fire and fan settings.

Pellet Wall Thermostat

COMPATIBILITY

- All Travis Gas Stoves & Inserts
- Newport Pellet Stoves & Inserts
- Pioneer Pellet Stoves & Inserts
- Astoria Pellet Stoves & Inserts
- Yankee Pellet Stoves & Inserts

ITEMS NEEDED FOR ASSEMBLY

- Standard Screwdriver
- Additional tools may be required for laying the thermostat wire
- You may need additional tools to access the on/off switch on certain gas heaters - refer to the instructions in the owner's manual.

PACKING LIST

- Thermostat
- Thermostat wire (20' long)
- 2 Screws (for attaching the thermostat to wall)

INSTALLATION INSTRUCTIONS

! This kit must be installed by a qualified technician.

! Do not connect 110 VAC to the gas control valve or on/off switch on gas heaters or the thermostat posts on pellet heaters.

Pellet Heater Installation
Attach the thermostat wire to the circuit board.

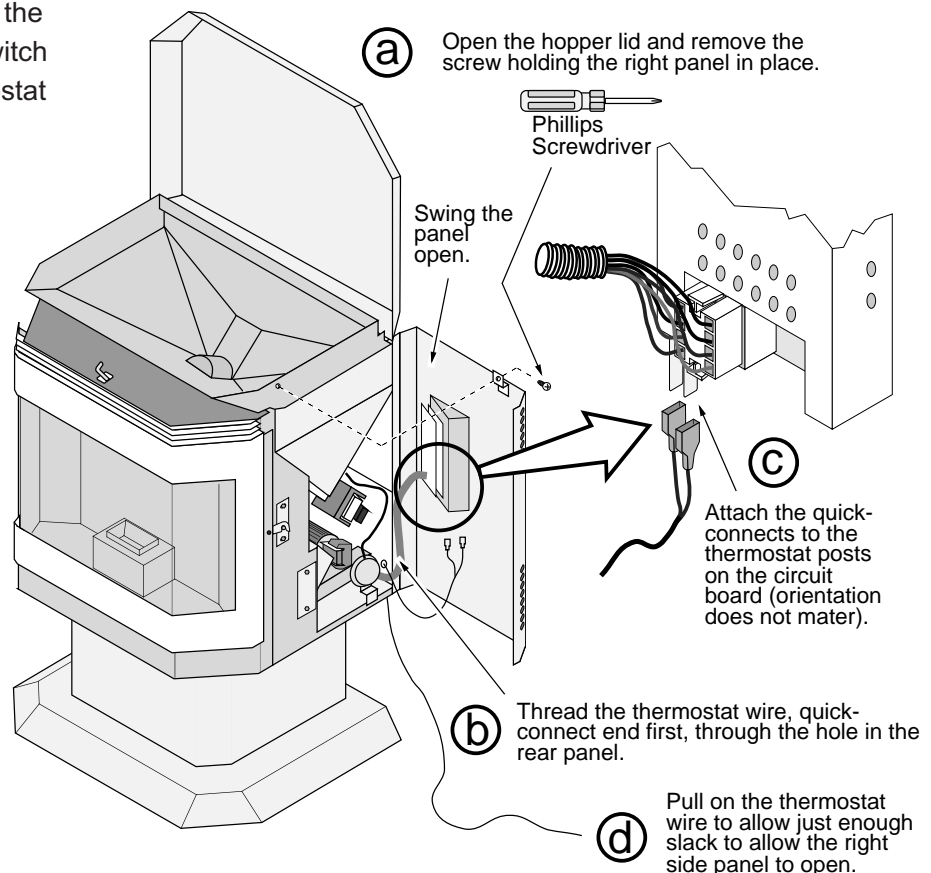

Pellet Wall Thermostat

Thermostat Placement and Installation

1. Determine a location for the thermostat that is within range of the 20' length of thermostat wire. It should be centralized in the room and away from the heater. The wire may be routed externally on the wall or behind the wall (preferred). Run the thermostat wire to this location. Use nylon ties, if necessary to keep the wire from contacting any hot portions of the heater.
2. Follow the directions below to attach the thermostat and thermostat wires.

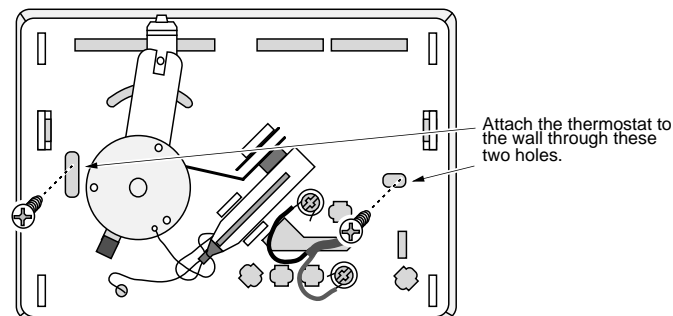
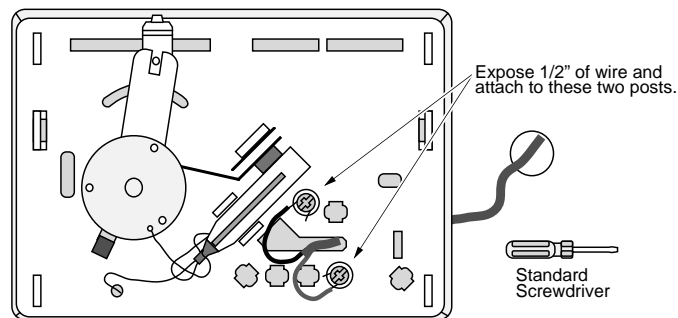
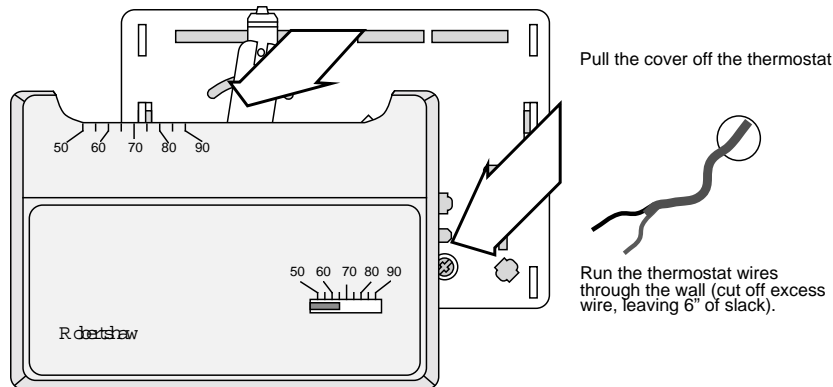

Pellet Remote Control

CHECK CONDITION OF SHIPMENT

Upon receipt of this kit, check the condition of the packaging. Damage to the package should be noted on the carrier's freight receipt. Any damage claims as a result of shipping must be handled through the shipper. Travis Industries will provide assistance in resolving shipping claims or replacing items not included in the package. Please report any missing items immediately.

COMPATIBILITY

• All Travis Gas Stoves & Inserts • Newport (Avanti) Pellet Stoves & Inserts • Pioneer (Heritage Bay) Pellet Stoves & Inserts

ITEMS NEEDED FOR ASSEMBLY

You may need tools for to access the on/off switch on gas heaters - refer to the instructions below and in the owner's manual.

PACKING LIST

• Receiver • Transmitter • Receiver Hanger • Pellet Stove Connector Wires • Gas Stove Connector Wires • 3 AAA Batteries

FCC REQUIREMENTS

Warning: Changes or modifications to this unit not expressly approved by the party responsible for compliance could void the user's authority to operate the equipment. This equipment has been tested and found to comply with the limits for a Class B digital device, pursuant to Part 15 of the FCC Rules. These limits are designed to provide reasonable protection against harmful interference in a residential installation. This equipment generates, uses, and can radiate radio frequency energy and, if not installed and used in accordance with the instructions, may cause harmful interference to radio communications. However, there is no guarantee that interference will not occur in a particular installation. If this equipment does cause harmful interference to radio or television reception, which can be determined by turning the equipment off and on, the user is encouraged to try to correct the interference by one or more of the following measures:

- Reorient or relocate the receiver.
- Increase the separation between the equipment and receiver.
- Connect the equipment into an outlet on a circuit different from that to which the receiver is connected.
- Consult the dealer or an experienced radio TV technician for help.

CANADIAN EQUIPMENT REQUIREMENTS

This digital apparatus does not exceed the (Class A/Class B) limits for radio noise emissions from digital apparatus set out in the Radio Interference Regulations of the Canadian Department of Communications. Le présent appareil numérique n'émet pas de bruits radioélectriques dépassant les limites applicables aux appareils numériques (de la class A/de la class B) prescrites dans le Règlement sur le brouillage radioélectrique édicté par le ministère des Communications du Canada.

This device complies with RSS-210 of Industry and Science Canada. Operation is subject to the following two conditions: (1) this device may not cause interference, and (2) this device must accept any interference, including interference that may cause undesired operation of the device.

INSTALLATION INSTRUCTIONS

- ! Shut off power to the appliance and allow it to cool prior to installation.
 - ! This kit must be installed by a qualified technician.
 - ! All 110 VAC wiring must be done by a qualified electrician and shall be in compliance with local codes and the National Electric Code ANSI/NFPA No. 70 (in the United States), or with the current CSA C22.1 Canadian Electric Code (in Canada).
 - ! Do not connect 110 VAC to the gas control valve or on/off switch on gas heaters or the thermostat posts on pellet heaters.
- 1 Remove the cover from the back of the transmitter and receiver. Slide the code switches to a random position on the receiver. Then position the switches on the transmitter to match the dip switch positions on the receiver. Prior to replacing the cover, place three AAA batteries inside the transmitter.

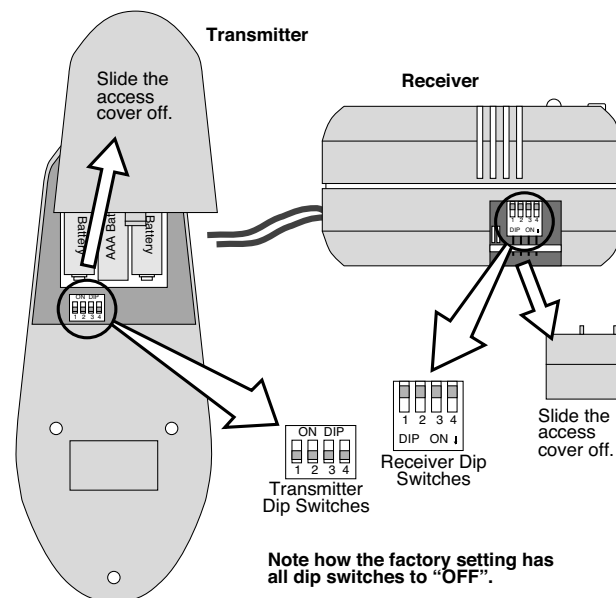

Pellet Remote Control

Gas Stove Installation

Place the receiver, with holder, on the back of the heater and route the receiver wires to the on/off switch (see the illustration below). Connect the receiver power cord to a 110 VAC outlet.

Attach one receiver and one gas control valve wire (orientation does not matter) to each gas stove connector wire - then attach the gas stove connector wires to the on/off switch (see the illustration at the bottom of the page).

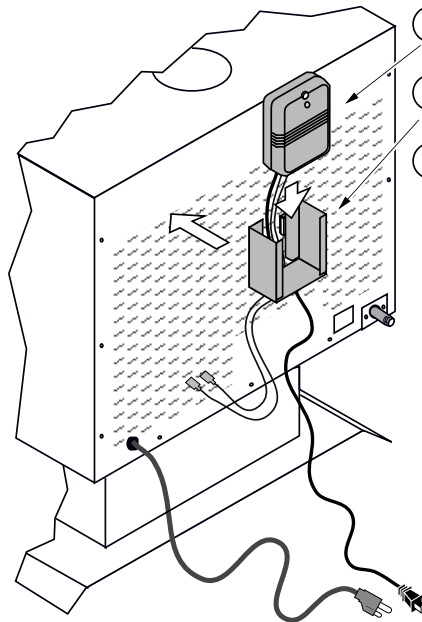

- a** Place the receiver into the holder with the wires exiting the rear.
- b** Place the holder against the rear panel. Route the power cord to a 110 VAC outlet.

Stoves with the on/off switch in back:
Route the thermostat wires through the rear panel, to the on/off switch (refer to the owner's manual for details on accessing the back of the on/off switch).

Stoves with the on/off switch in front:
Route the thermostat wires through the rear panel, along the base, under the wire clip (make sure the wires do not contact the burner pan).

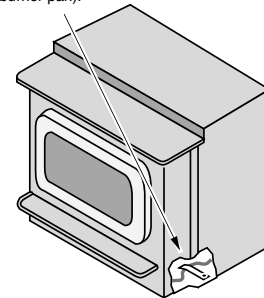

Gas Fireplace Insert Installation

Place the receiver, with holder, on the back of the right side surround panel and route the receiver wires to the on/off switch (see the illustration to the right). Connect the receiver power cord to a 110 VAC outlet.

Attach one receiver and one gas control valve wire (orientation does not matter) to each gas stove connector wire - then attach the gas stove connector wires to the on/off switch (see the illustration below).

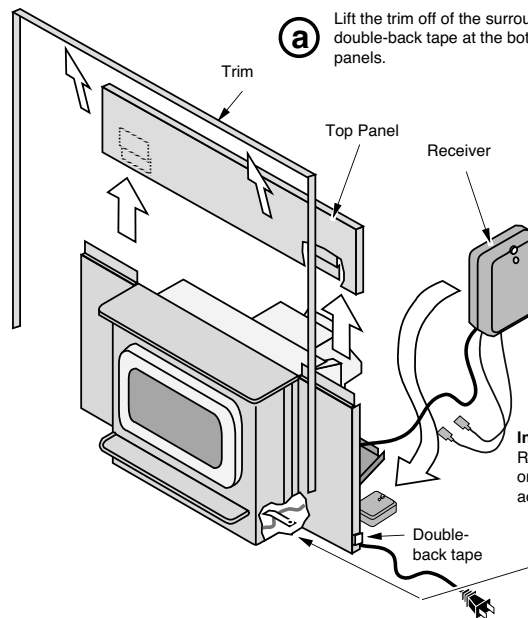

- a** Lift the trim off of the surround panels (you may need to peel the trim off the double-back tape at the bottom of the panels). Lift the top panel off the side panels.

- b** Place the receiver on the floor of the firebox, as far away from the insert as possible.

WARNING:
The receiver must be 3" away from the heater and below the top convection channel.

- c** Route the power cord away from hot or moving objects and behind the surround panel to a 110 VAC outlet.

Inserts with the on/off switch on the surround panel:
Route the thermostat wires through the rear panel, to the on/off switch (refer to the owner's manual for details on accessing the back of the on/off switch).

Inserts with the on/off switch in front:
Route the thermostat wire along the base of the insert and under the wire clip (make sure the wires do not contact the burner pan).

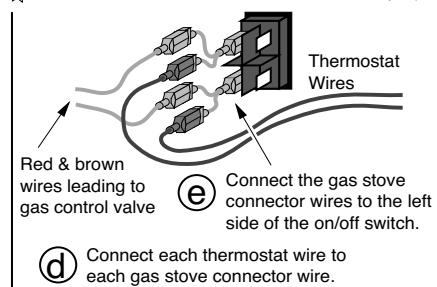
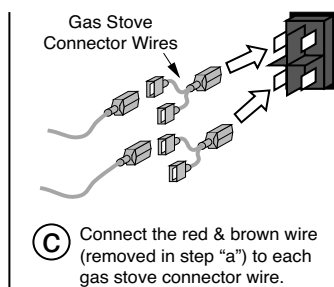
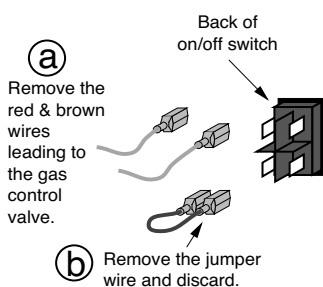

Pellet Remote Control

Pellet Stove Installation

Place the receiver holder on the back of the heater and route the receiver wires to the on/off switch (see the illustration to the right). Connect the receiver power cord to a 110 VAC outlet.

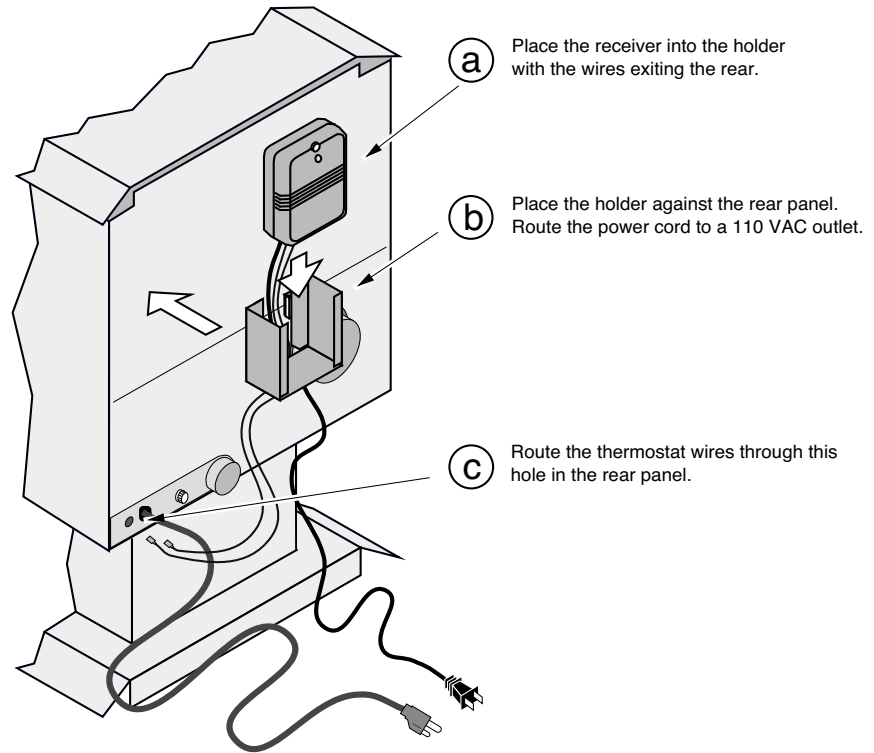

Attach the pellet stove connector wires to the ends of the receiver wires. Then attach the connector wires to the back of the circuit board (see the illustration to the right).

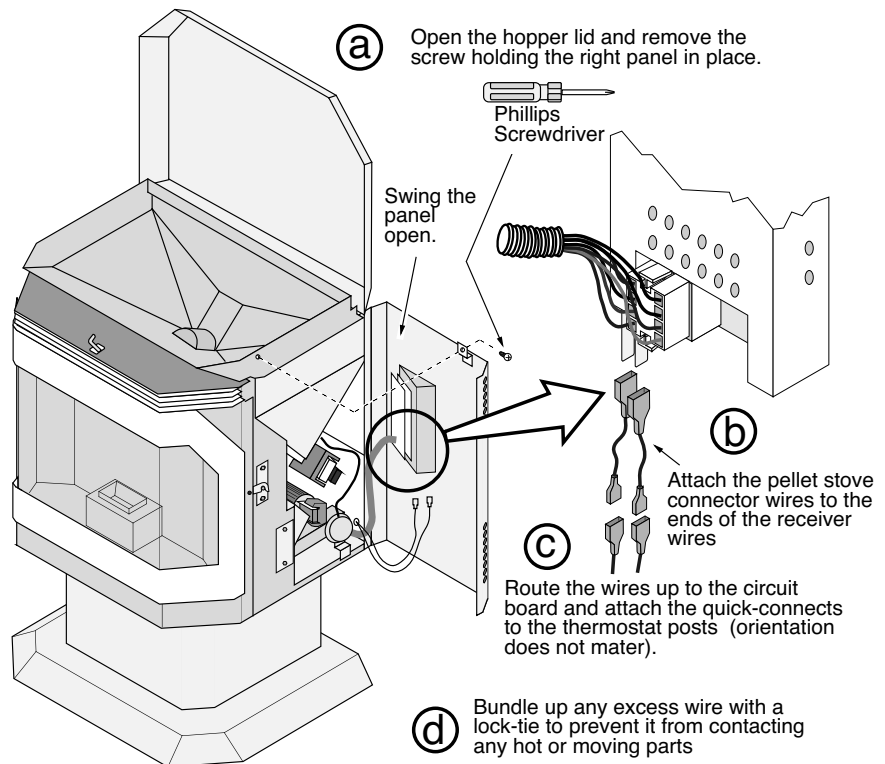

Pellet Remote Control

NOTE: The pilot flame must be lit, the gas control valve turned to "ON", and the on/off switch turned to "OFF" for the remote to work correctly.

NOTE: This kit must be installed by a qualified technician.

MANUAL MODE:

TO SET TO MANUAL:
Use the arrow keys to adjust the target temperature to 90°.

TO TURN ON AND OFF:
Use this key to toggle the heater on and off. The display will indicate the status.

NOTE:
If the room exceeds 90°, the heater will shut off.

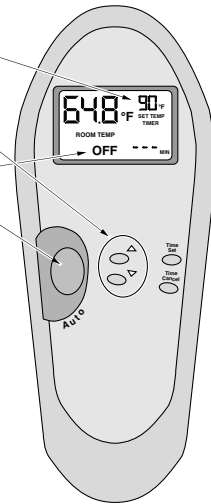

THERMOSTAT MODE:

TO SET TO THERMOSTAT MODE:
Use this key to toggle the thermostat mode on. The display will indicate "ON" in the lower left.

HINT:
If your heater turns on and off frequently, adjust the flame height (burn rate on pellet heaters) down slightly for a more consistent heat output.

TO ADJUST TARGET TEMPERATURE:
Use the arrow keys to adjust the target temperature to the desired level.

The heater will turn on and off to keep the room temperature near the target temperature.

IMPORTANT OPERATIONAL NOTE:
The thermostat has a built-in time delay to keep the heater from constantly turning on and off. This means the target temperature may be slightly higher (2° or 3°) than the room temperature – do not adjust the target temperature – the heater will turn on in a few minutes.

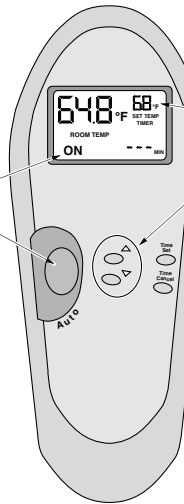

TIMED MODE:

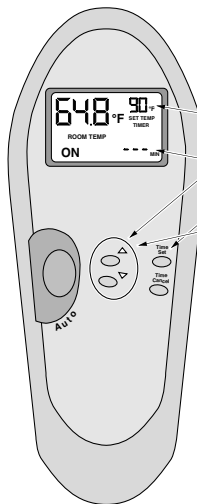

TO SET TO TIMED OPERATION:

- Use the arrow keys to adjust the target temperature to 90°.
- Press the "Time Set" button - the " - - - " will start to flash.
- Use the arrow keys to set the number of minutes you would like the heater to stay on.

The heater will turn on and stay running for the number of minutes displayed.

NOTE:
If the room exceeds 90°, the heater will shut off.

REPLACING THE BATTERIES:

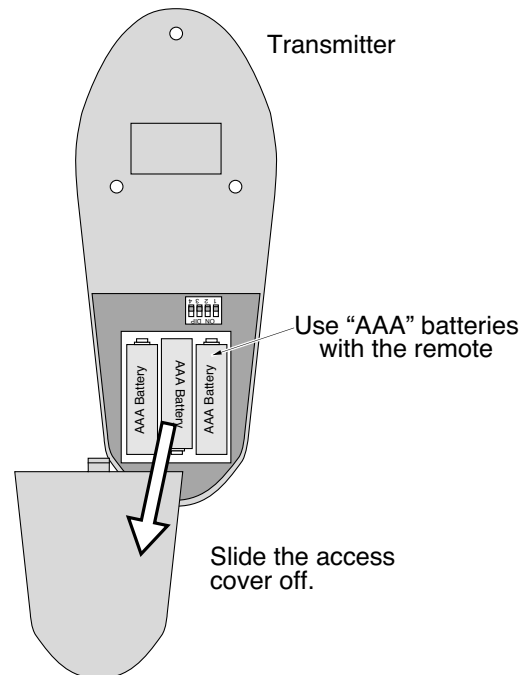

POWER OUTAGES:

If a power outage occurs, the receiver will turn the heater off. Once power is restored, the remote will turn the heater on (if the remote calls for heat) within 30 minutes. If you wish to over-ride the remote and turn the heater on (gas stoves only), turn the on/off switch on the gas heater to "ON".

Freestanding Stove Outside Air (Small or Large Pellet Stove)

Outside Air (used for combustion)

- Must not be drawn from an enclosed space (garage, unventilated crawl space).

HINT: Travis Industries strongly suggests outside air for all residential installations, especially for those that are energy efficient, air-tight homes.

- Must not be over 15' long.
- Must be made with 1 3/4" diameter or larger metal or aluminum duct with a metal screen attached to the end to keep out rodents (P.V.C. or other combustible materials may not be used). We recommend the Travis Industries Outside Air Kit (part # 99200136).
- Must not terminate above or within 1' of the chimney termination.
- Must have a rain cap or down-turned elbow to prevent water from entering.
- Must be located so that it will not become plugged by snow or other material.

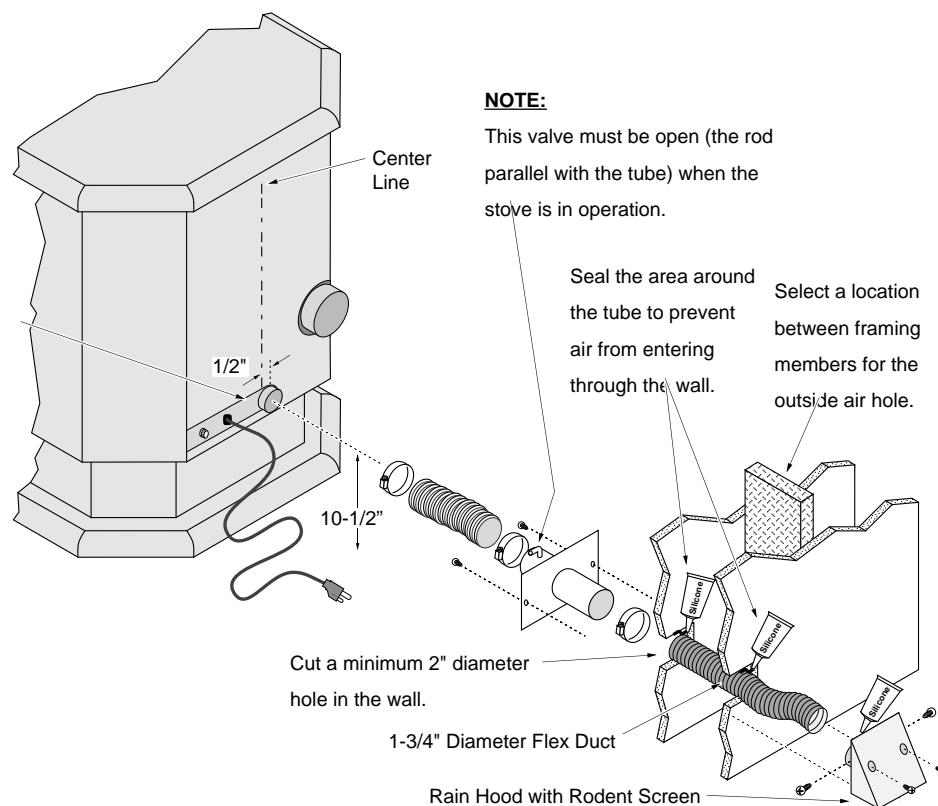

Fireplace Insert Outside Air (Small or Large Pellet Insert)

Outside Air (used for combustion)

- Outside air is optional (except in mobile homes or when required by local building codes).
- Must not be drawn from an enclosed space (garage, unventilated crawl space).
- Must not be over 15' long.
- Must be made with 1 3/4" diameter or larger metal or aluminum duct with a metal screen attached to the end to keep out rodents (P.V.C. or other combustible materials may not be used). Use the Travis Industries Outside Air Kit (part # 99200136).
- Must not terminate above or within 1' of the chimney termination.
- Must have a rain cap or down-turned elbow to prevent water from entering.
- Must be located so that it will not become plugged by snow or other material.

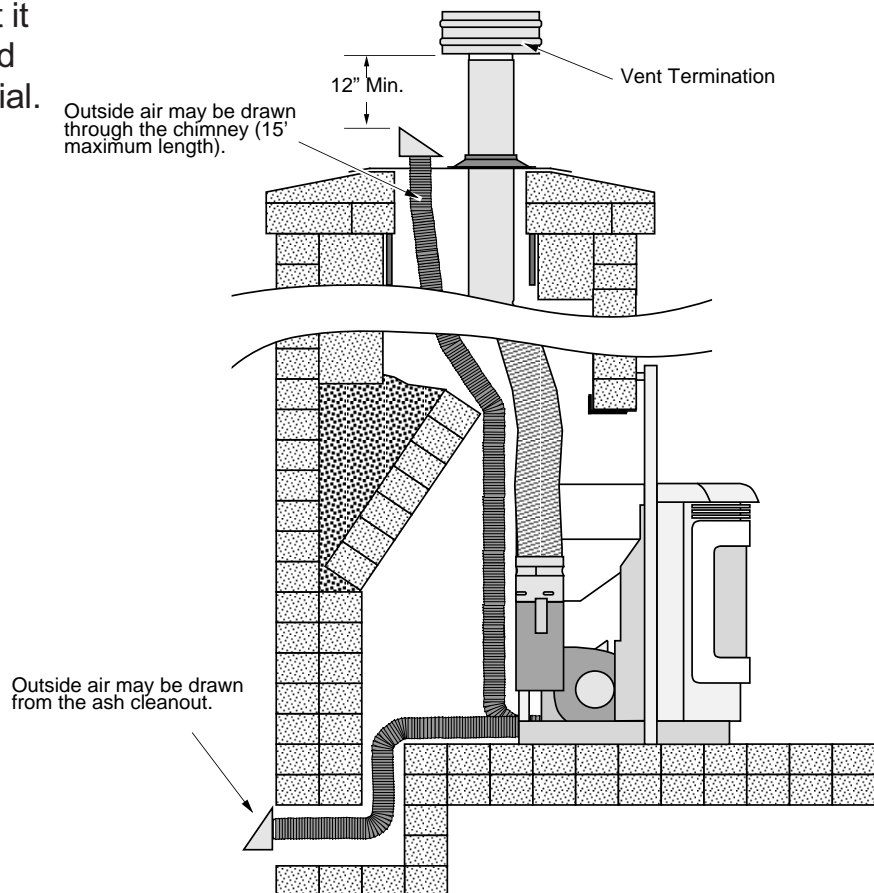

Pellet Vent

Pellet Vent

- Rigid Pipe
- 3" & 4"
- 6", 1', 2', 3',
& 5' Lengths
- Galvanized
or Black

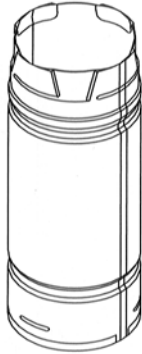

- Ridged pipe comes in 3" & 4" diameters.
- Lengths include 6", 1', 2', 3', & 5'.
- Galvanized or painted black
- Flex pellet vent comes in 3" & 4" diameters.

Pellet Vent

- Flex Pipe
- 3" & 4" Dia.
- 5' Length
- 4 Ply S.S. Flex
- Twist Lock
- Ceramic Rope Gasket



- Length is 5'.
- 4 ply Type 430 S.S. flex.
- Ceramic rope gasket is used to prevent fly ash leakage.
- Flex pipe may be used in combination with ridged pipe when venting an insert.

Pellet Vent

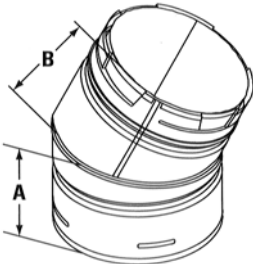

- Elbow comes in 45° or 90° and in 3” or 4” diameters.

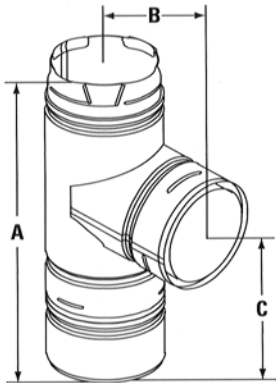
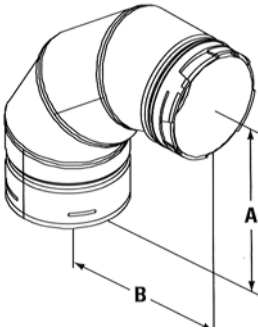

- Tee with clean-cut in 3” or 4” diameters.

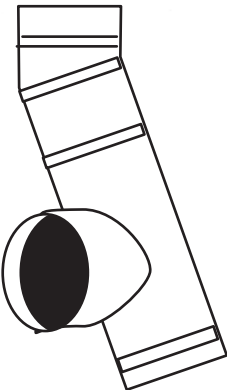

- Center flue adapter in 3” or 4” diameters.

Pellet Vent

- Pellet vent is a Type “L” classified vent.
- Type “L” vent is rated for flue temperatures up to 570°F.
- Pellet Vent is a two wall constructed vent
- The inner vent is made of stainless steel - .012 Type 430 SS.
- The outer liner is made of galvanized steel - .018.
- Each joint contains a high temperature ceramic rope gasket to prevent fly ash leakage.
- Pellet vent employs easy, twist lock connections.

Clearances - Straight Installation

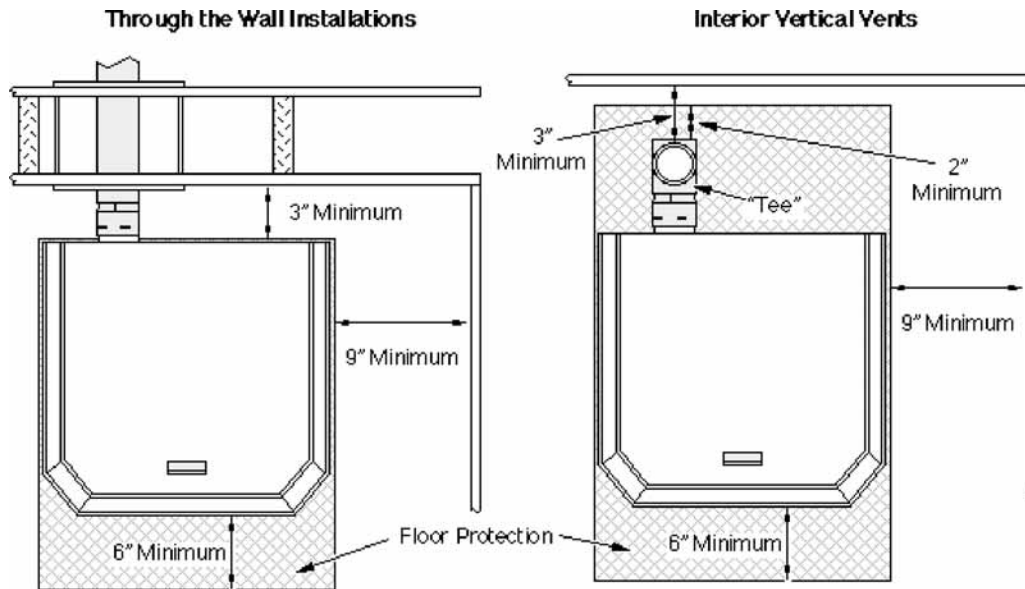

Clearances - Corner Installation

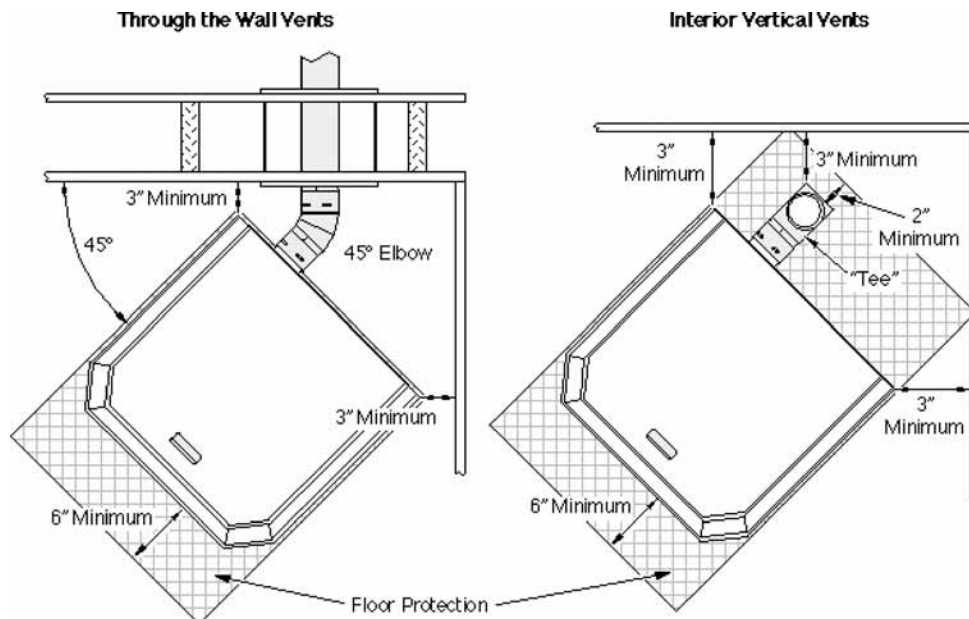

Note: If interior vertical pellet vent is used, the clearance to the backwall is determined by the upward-turning elbow or "Tee." It will vary in depth depending on the brand of pellet vent used (it is approximately 5"). Before placing the heater, connect the elbow or "Tee" and measure off the 3" clearance.

Venting the Pellet Stove

- Pellet vent must maintain a minimum 3" clearance to any combustible (install vent at clearances specified by the vent manufacturer).
- Do not connect the pellet vent to a vent serving any other appliance or stove.
- Do not install a flue damper in the exhaust venting system of this unit.
- Use an approved wall thimble when passing the vent through walls and a ceiling support/fire stop spacer when passing the vent through ceilings (make sure to maintain 3" clearance to any combustibles).
- No more than 180 degrees of elbows (two 90 degree elbows, or two 45

Maximum Venting Distance:

- Vent must have a support bracket every 5' of pellet vent when exterior of structure.
- If the heater is installed at an altitude over 4,000' use 4" diameter for all applications.

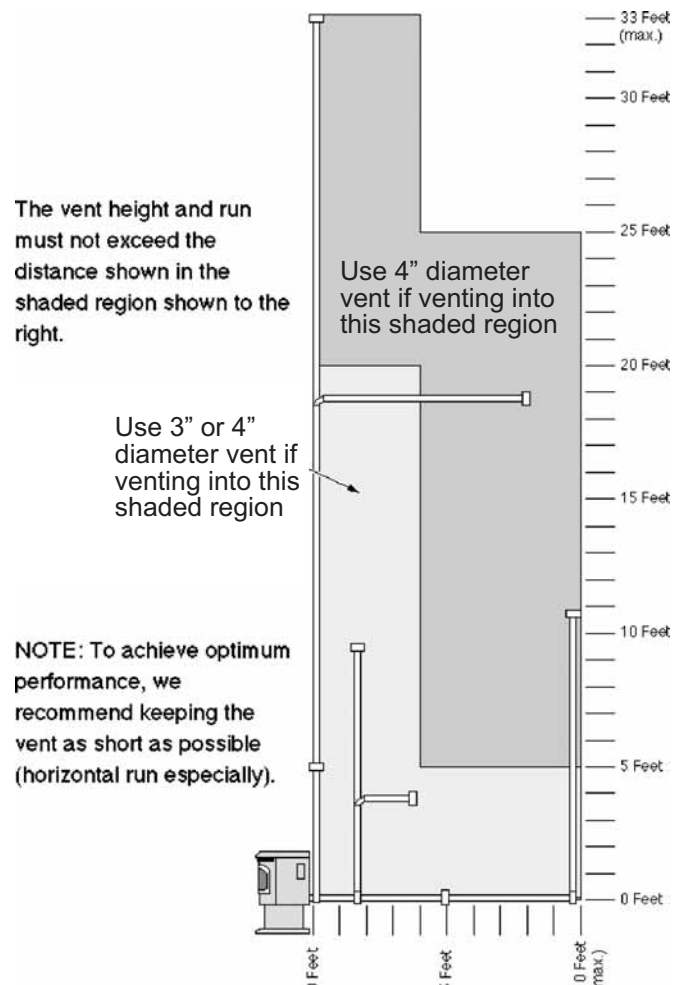

Pellet Vent Type

- Must be Type "L"(except for masonry fireplace installations) - or - connect the vent to a factory built type "A" chimney (use an adapter and seal all joints).

Installing the Pellet Vent



Seal each vent section by applying a liberal amount of 500° F RTV silicone around the gap between sections.

- Horizontal sections must have a 1/4" rise every 12" of travel.
- Pellet vent connections must be sealed airtight with 500° F. RTV silicone and screwed together with at least three sheet metal screws.

HINT: The Travis Industries Center Flue Adapter has less depth than a standard "tee" and centers the flue, easing installation.

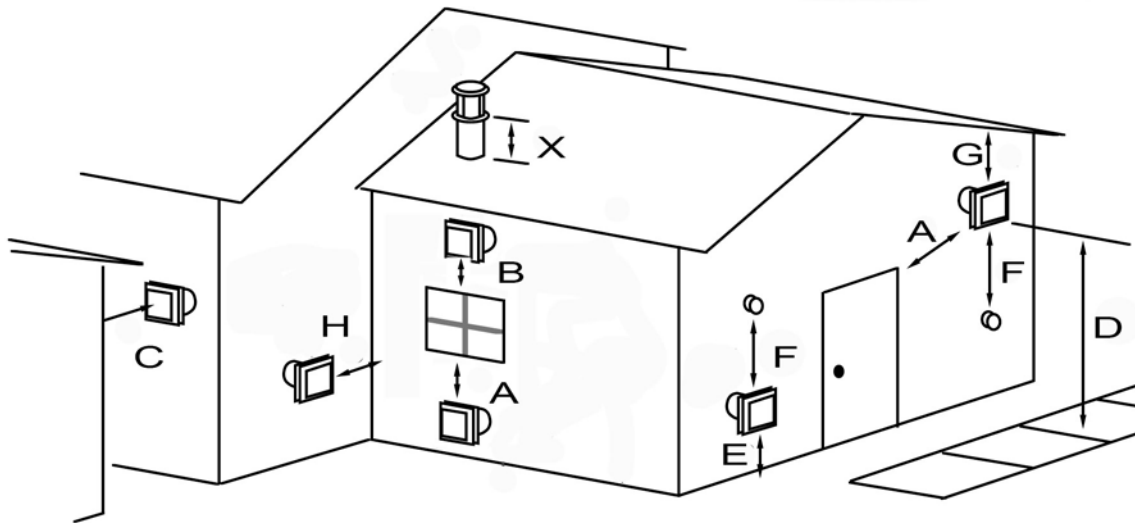

NOTE: Measure clearances to the nearest edge of the exhaust hood.

Pellet Vent Termination (See the illustration above)

- Must have an approved cap (to prevent water from entering) or a 45° downturn.
- If the termination is located on a windy side of the house, an approved house shield is recommended to prevent soot from building up on the side of the house.
- Must not be located where it will become plugged by snow or other material.
- Horizontal terminations must protrude 12" from the wall, vertical terminations require 24".

- A Minimum 4' clearance below or beside any door or window that opens
 B Minimum 1' clearance above any door or window that opens
 C Minimum 2' clearance from any adjacent building
 D Minimum 7' clearance above any grade when adjacent to public walkways
 NOTE: Vent may not terminate in covered walkway or breezeway.
 E Minimum 2' clearance above any grass, plants, or other combustible materials
 F Minimum 3' clearance from any forced air intake of any other appliance
 G Minimum 2' clearance below eaves or overhangs
 H Minimum 1' clearance horizontally from combustible wall
 X Must be a minimum of 2' above the roof

Installation Example: Direct "Through-the-wall" Installation

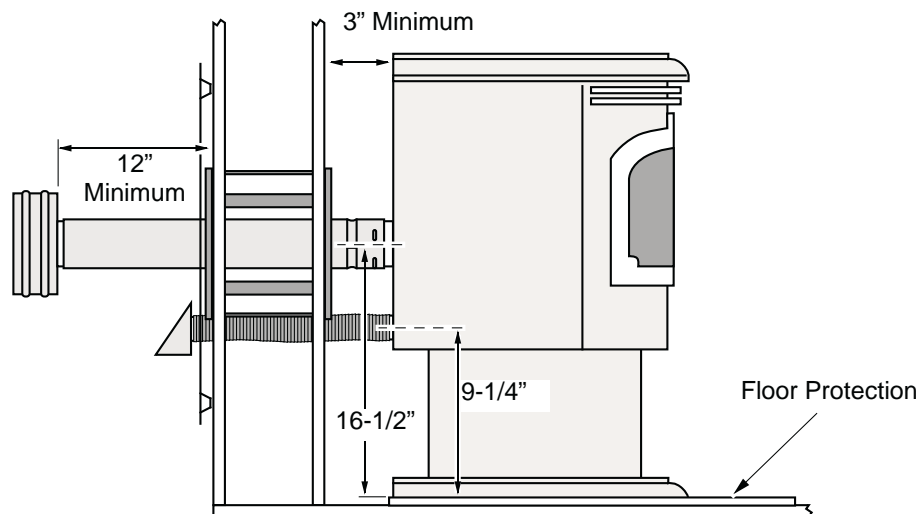
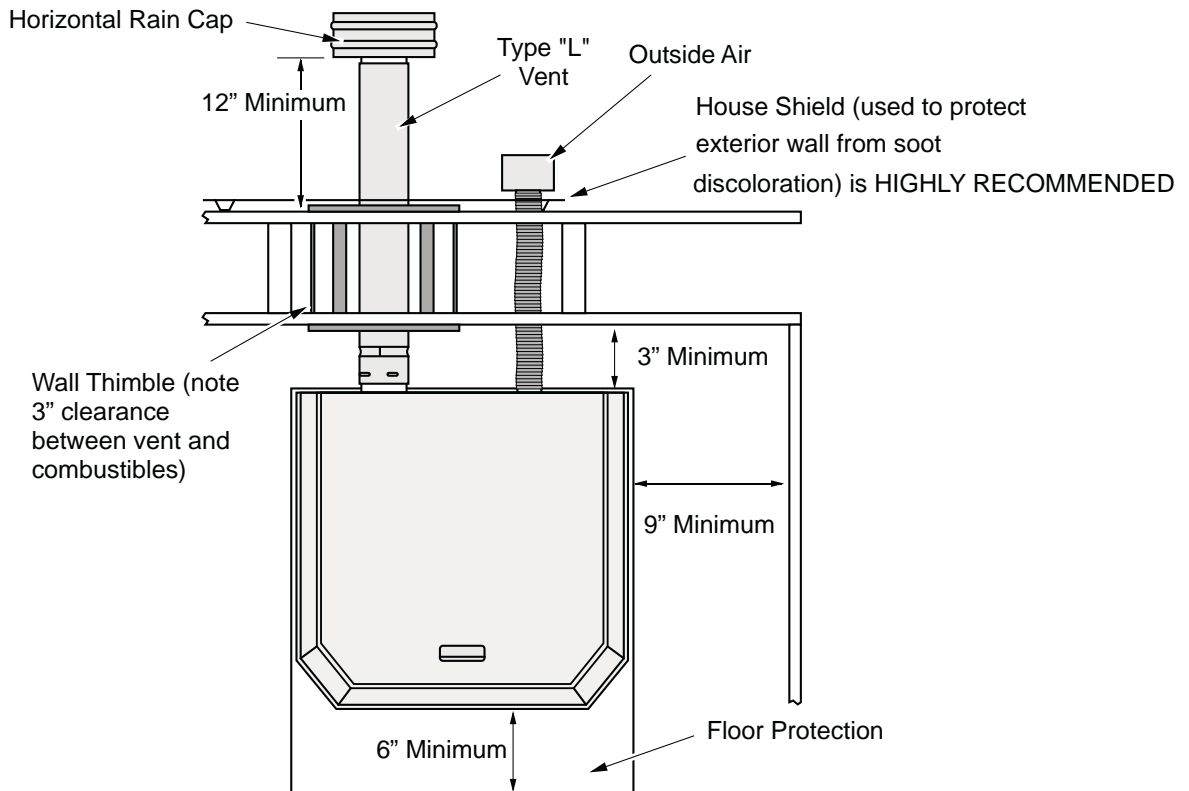

Installation Example: Direct "Through-the-wall" Installation

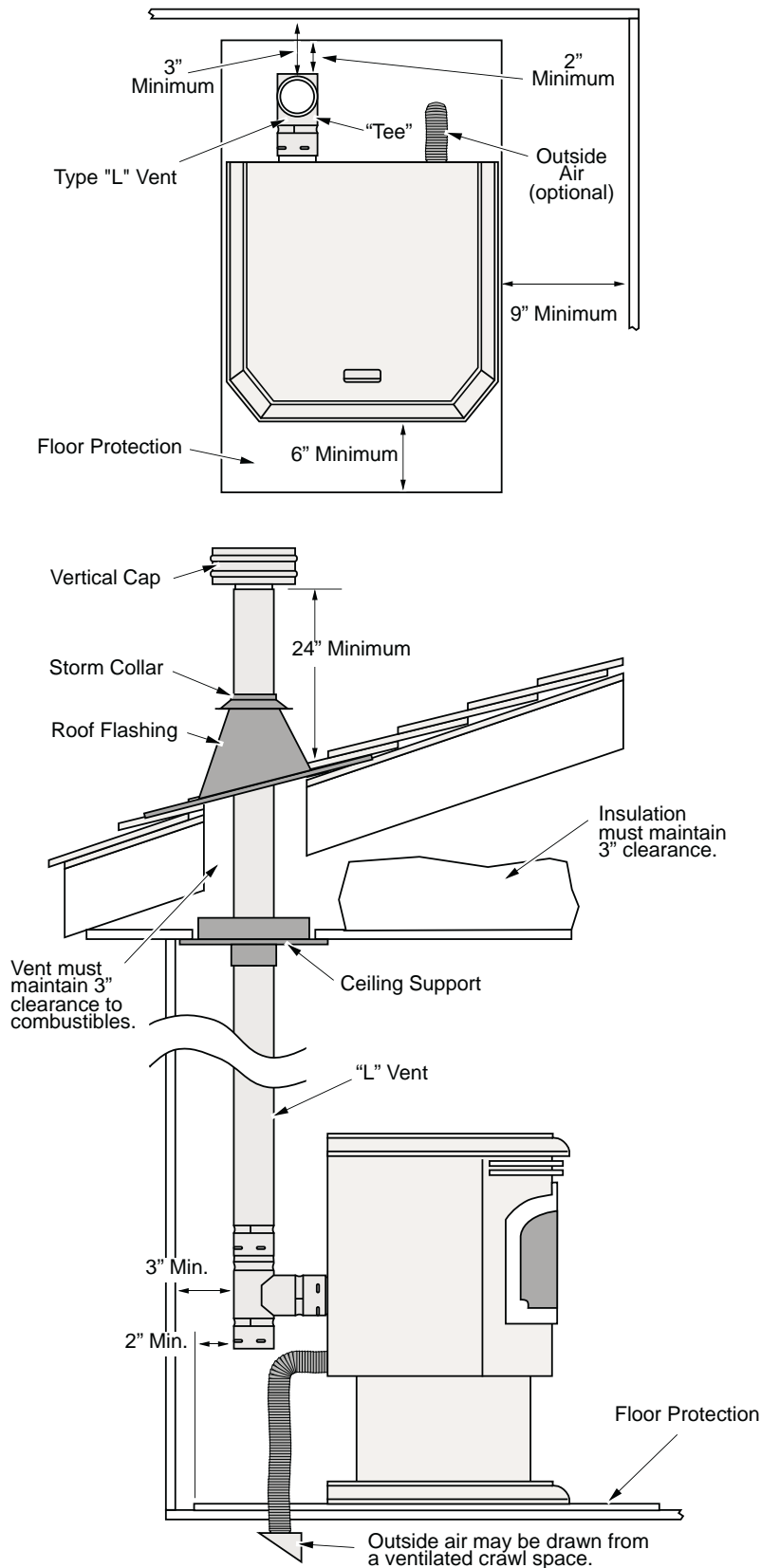

TRAVIS INDUSTRIES PELLET PRODUCTS



Installation Example: Hearth Fireplace (Masonry or Z.C. (metal))

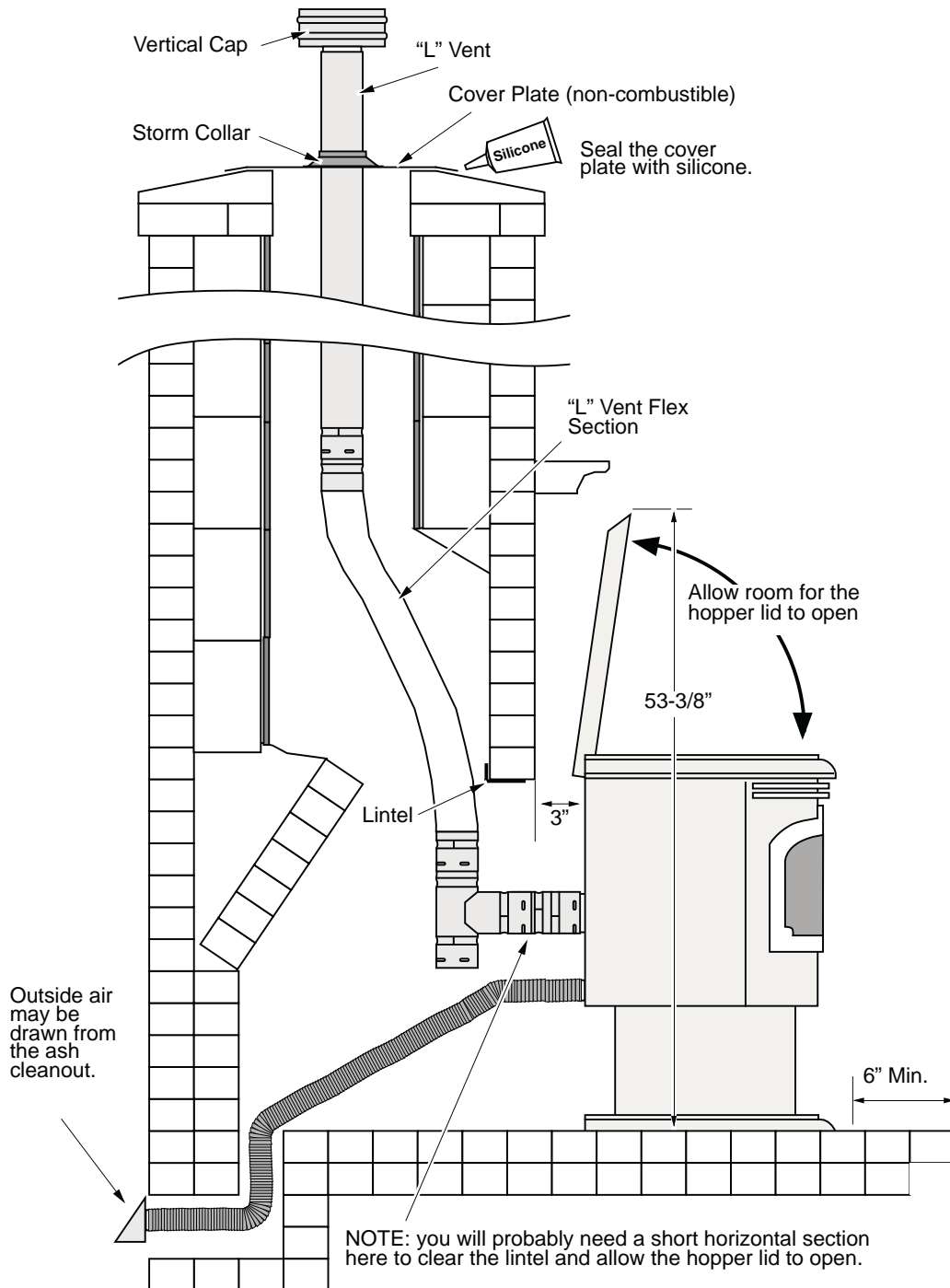

TRAVIS INDUSTRIES PELLET PRODUCTS



Clearances - Straight Installation

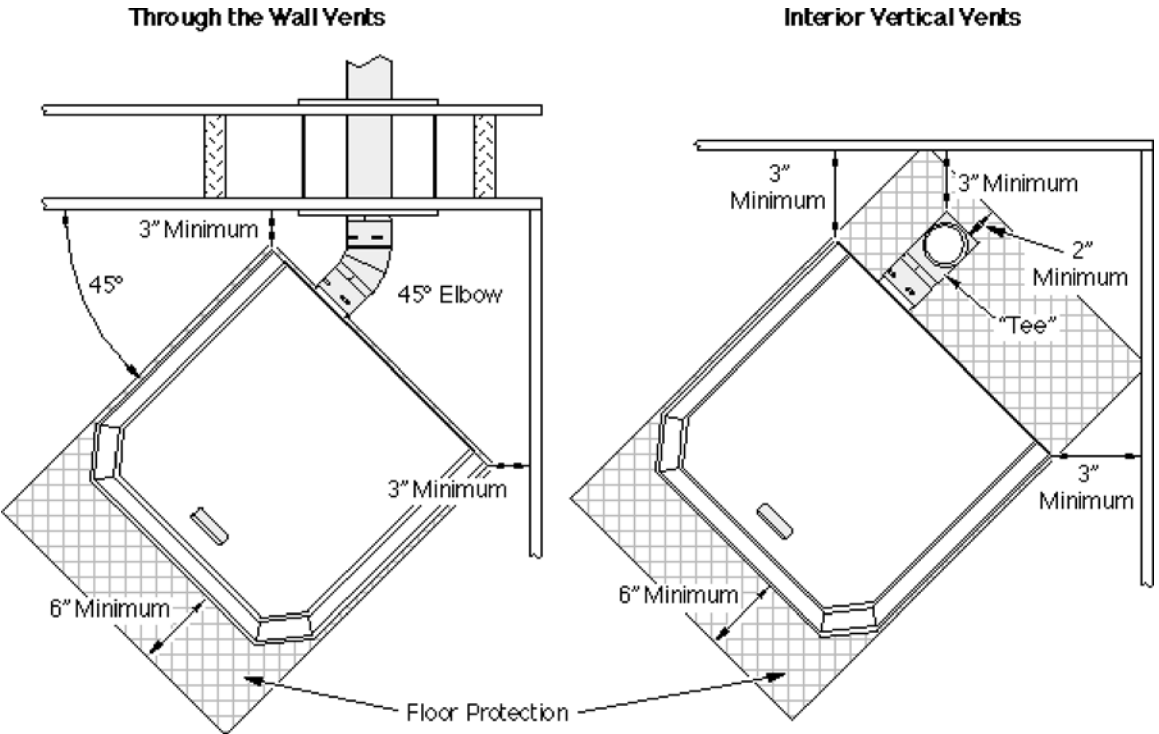
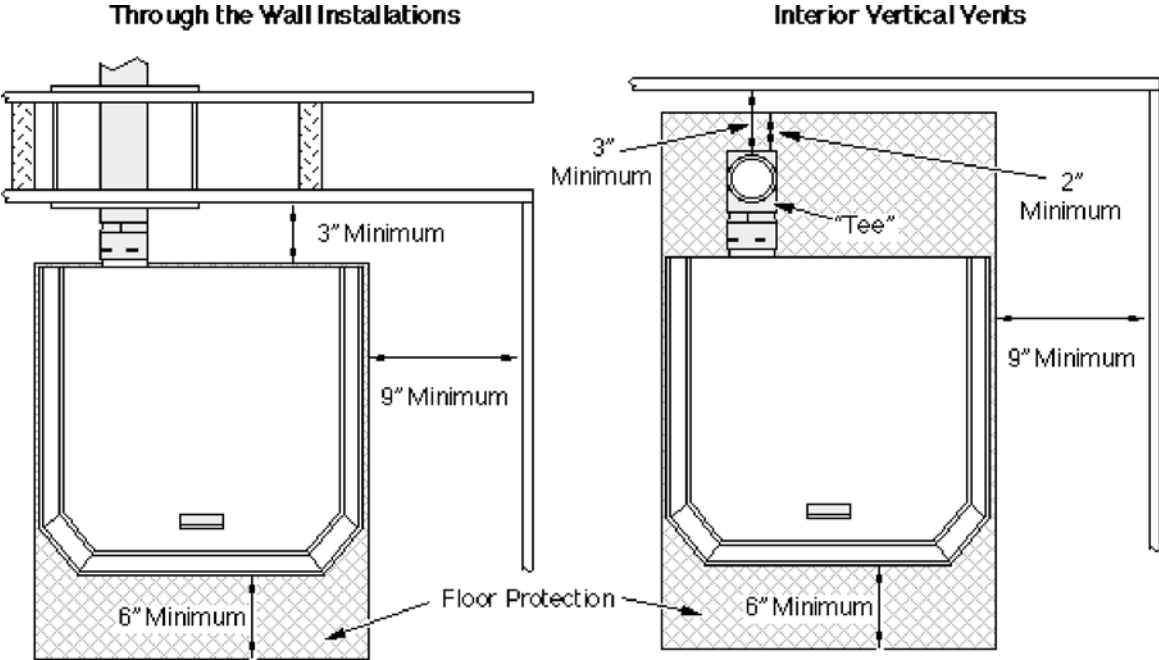

Small Stoves/Inserts Upgrade Kit



TRAVIS INDUSTRIES
HOUSE OF FIRE

Restrictor Retrofit Installation

For the Pioneer PS & PI, Newport PS & PI -- See the SKU's below

Compatibility

Pioneer PS or Newport PS	221-11090
Pioneer Bay PI	221-11085
Newport Bay PI	221-11088

When to Use This Kit

This kit replaces the stock intake restrictor with a new restrictor that allows for restrictor adjustment while the heater is in operation. This kit is only intended for those units requiring frequent restrictor adjustment (often due to inconsistent fuel).

Important Warnings

Turn off electricity to the appliance and make sure it has fully cooled prior to conducting service.

Packing List

- Restrictor Plate with Handle (see the illustration below)

Pioneer PS and Newport PS

Newport Bay PI

Pioneer Bay PI

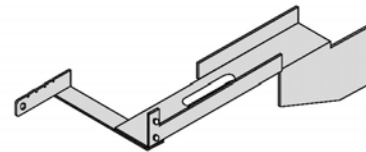
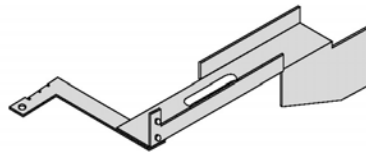
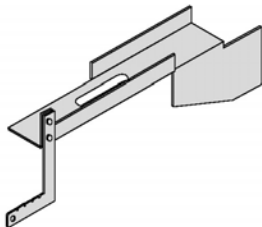

- Bullet Catch Bracket
- Hex Nut (1/4-20)

Installation

1. Gain access to the right side of the heater. On inserts, remove the surround panels. On stoves, open the hopper, remove the screw holding the right side panel in place, and swing the panel open.
2. For inserts, remove the right side convection front (see the illustration to the right).

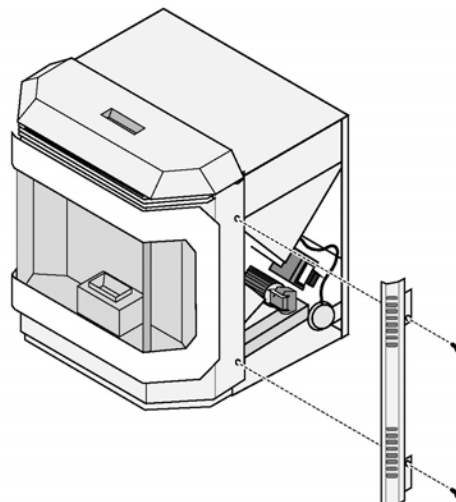

Small Stoves/Inserts Upgrade Kit

3. Remove the stock restrictor following the directions below.

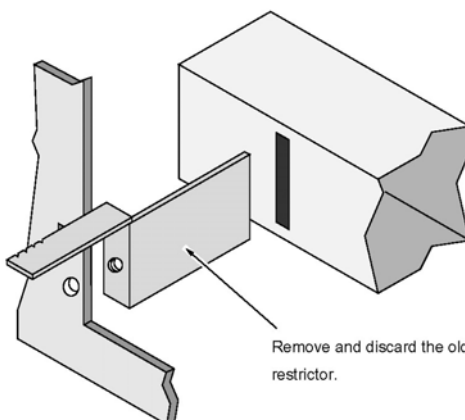
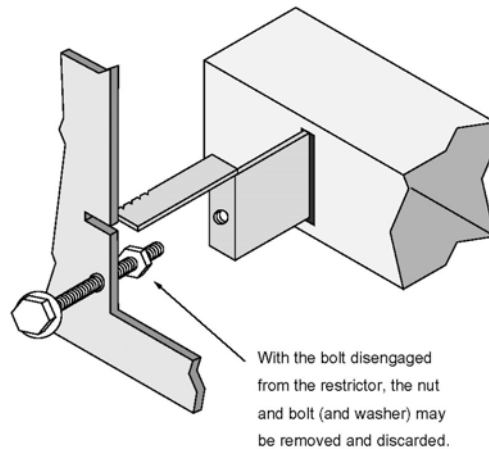
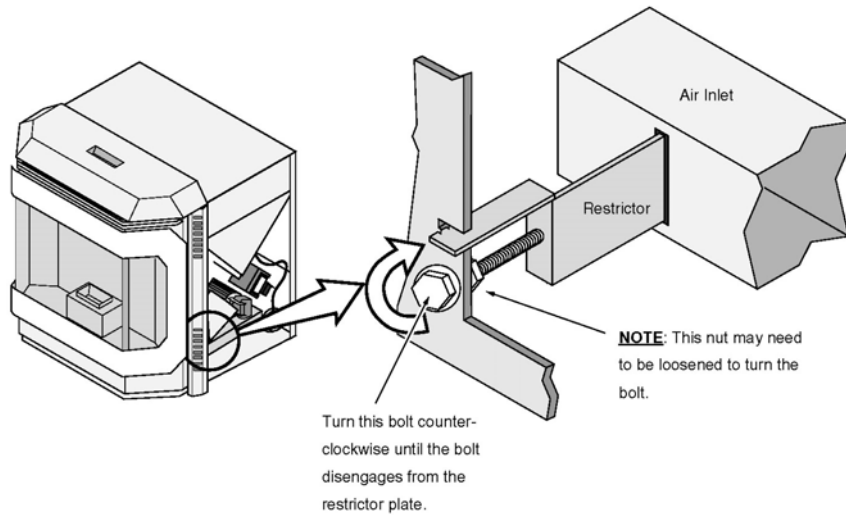

Small Stoves/Inserts Upgrade Kit

4. Install the bullet catch bracket following the directions below.

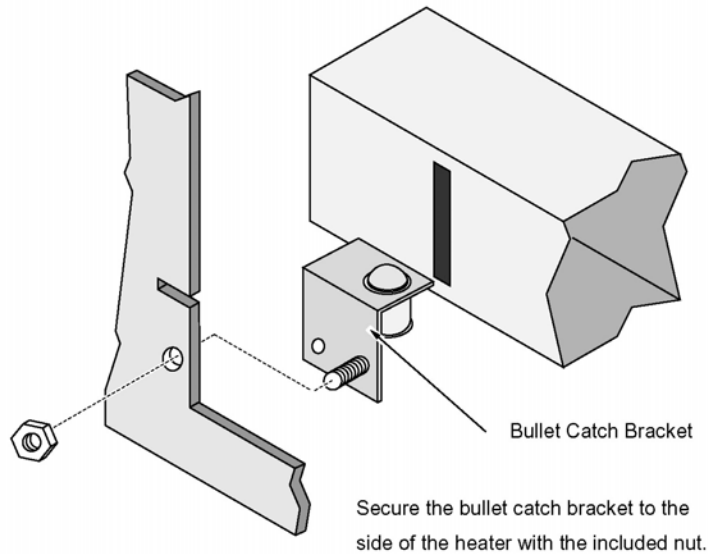

5. Install the new restrictor following the directions below.

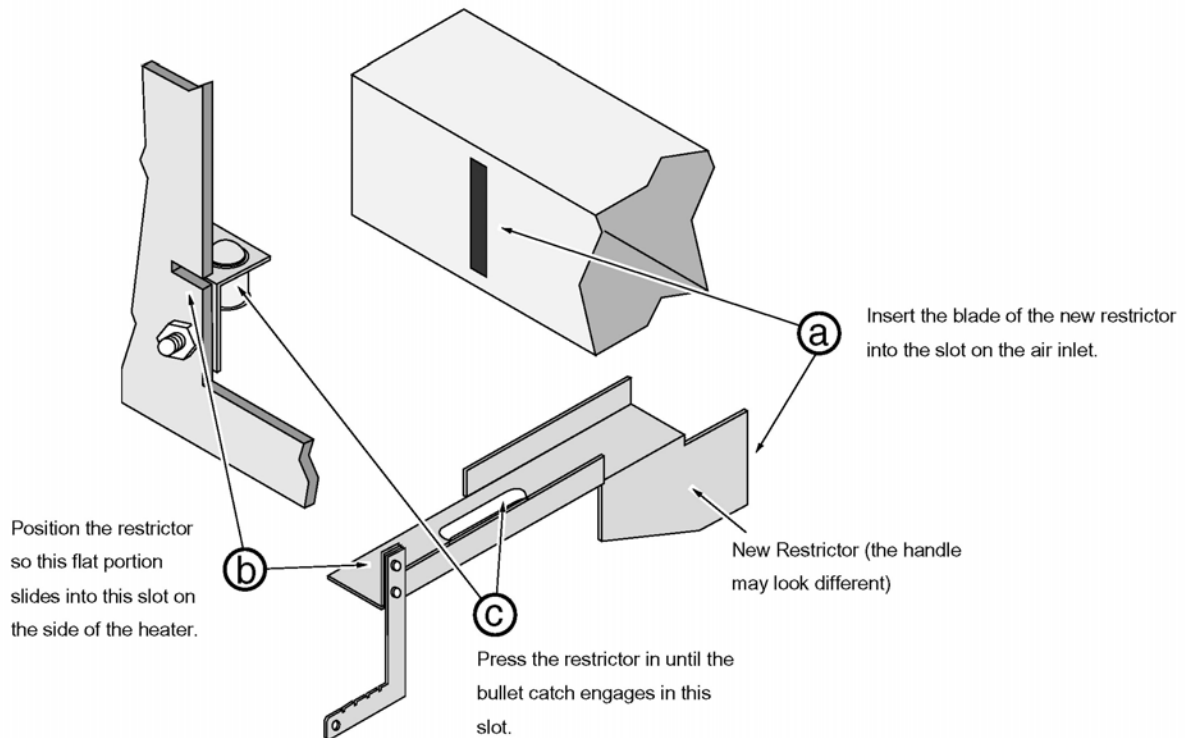

6. Return the heater to its original configuration (on inserts replace the side convection front).

Small Stoves/Inserts Restrictor Setting Instructions

Restrictor Adjustment

The restrictor “fine tunes” your appliance, adjusting the amount of air flowing to the flame.

NOTE: the optimal restrictor position will vary over time as soot builds up inside the exhaust system.

Not Enough Air:

If clinkers develop or the flame appears lazy and slow to blow the ash out of the firepot, pull the restrictor outward until the flame becomes active and the firepot holes remain clean. NOTE: If the restrictor is fully out yet the firepot does not remain clean, the stove needs to be cleaned and checked for air leaks (see “Maintenance” section of this manual).

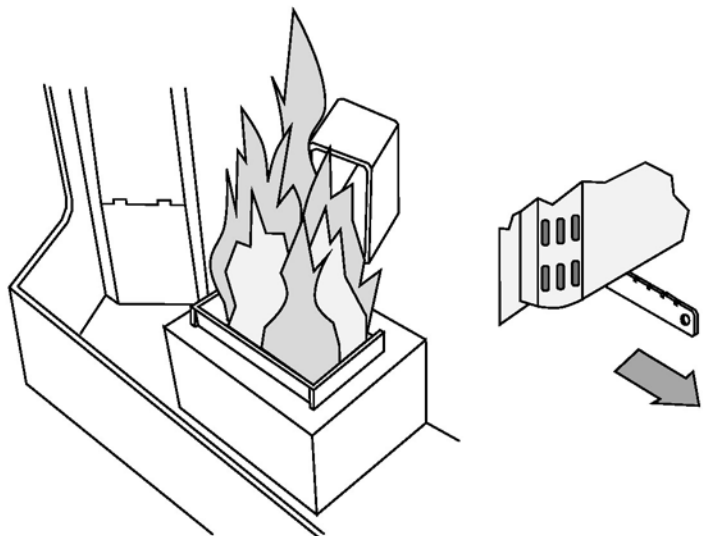

Too Much Air:

If the flames are too active (small, flickering flames) or if burning pellets are expelled from the firepot, move the restrictor rod inwards until the flame slows down and no burning pellets are expelled. Another symptom of too much air is the heater “blowing the fire out” – a condition in which the pellets burn faster than they are fed (this is most common on low).

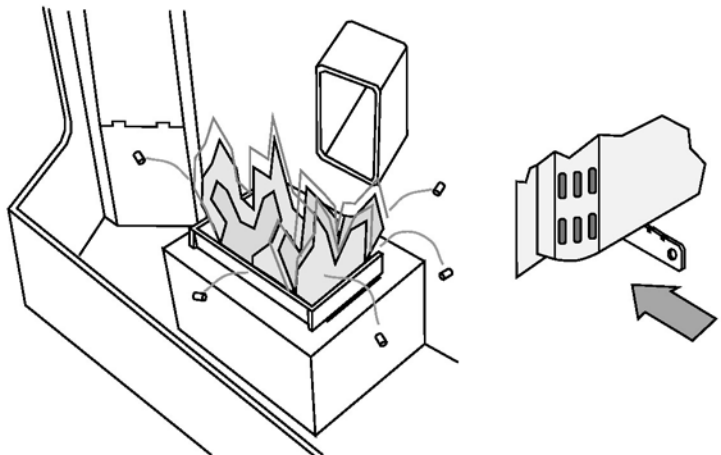

Large Stoves/Inserts Restrictor Setting Instruction

Restrictor Adjustment

The exhaust restrictor “fine tunes” your appliance, ensuring it pulls the correct amount of air through the firebox. Altitude, vent configuration, and other factors make restrictor adjustment necessary for every installation.

NOTE: the optimal restrictor position will vary over time as soot builds up inside the exhaust system – make sure the homeowner knows how to visually inspect the flame and adjust the restrictor.

Not Enough Air:

If clinkers develop or the flame appears lazy and slow to blow the ash out of the firepot, pull the restrictor outward until the flame becomes active and the firepot holes remain clean. **NOTE:** If the restrictor is fully out (“5”), yet the firepot does not remain clean, the stove needs to be cleaned and checked for air leaks (see “Maintenance” section of this manual).

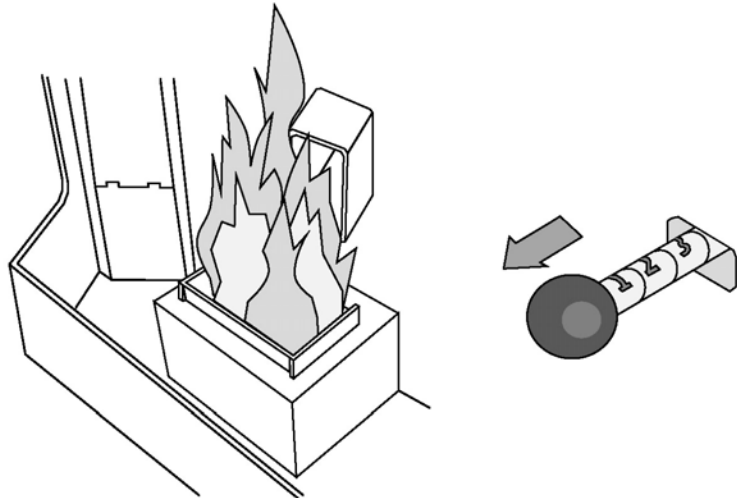

Too Much Air:

If the flames are too active (small, flickering flames) or if burning pellets are expelled from the firepot, move the restrictor rod inwards until the flame slows down and no burning pellets are expelled. Another symptom of too much air is the heater “blowing the fire out” – a condition in which the pellets burn faster than they are fed (this is most common on low).

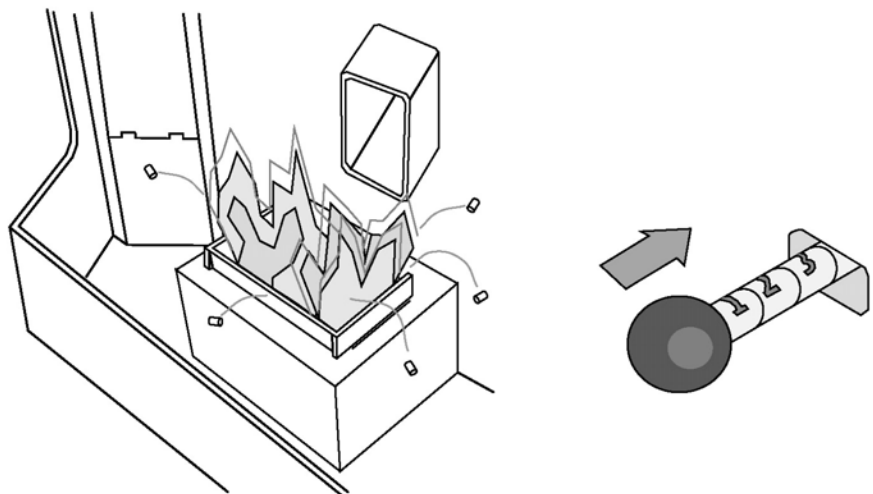





Restrictor Adjustment

- The appliance should be fully up to temperature (15-20 Min.) before attempting adjustment.
- Turn the appliance to low.
- Watch the burn pot activity to determine need for adjustment.
- Adjust as necessary.
- Turn heat setting to high to verify it operates well on this setting.

AIR FLOW INTO THE BURN POT	
SHOULD	SHOULD NOT
Be strong enough to create complete burning of the pellets	Burn so slow that incoming pellets smother the fire
Be strong enough to blow ash out of the burn pot	Let excessive amounts of ash lie in the burn pot
	Blow unburned pellets out of the burn pot

Pellet Stove Restrictor Setting

CONDITION	More Restriction of Air Flow (Too Much Air)	Less Restriction of Air Flow (Too Little Air)
Stove goes out on low burn		
Unburnt pellets are blowing out of burn pot		
Fly ash remains in the burn pot		
Pellets smother the fire		
Stove works fine during day but at night goes out leaving an unburnt pile of pellets (Due to cooler night temperature, draft in vent increases)		

Pellet Stove Maintenance

DAILY	Bi-Weekly or Every 10 Bags of Pellets	Annually or Every Two Tons of Pellets
<ul style="list-style-type: none"> • Inspect burn for proper attributes of proper color and no excessive build up of pellets. • Check firepot for clinkers and clean as necessary. 	<ul style="list-style-type: none"> • Clean heat exchange tubes with built-in rake. • Vacuum out hopper (let pellets run out) to remove all fines and debris. • Cleaning of plated surfaces - CAUTION: follow instructions to prevent damage to the plating. • Check ashbox (all inserts) and empty as necessary. • Check ash pan - empty as necessary. • Clean the glass with a nonabrasive cleaner. • Open ash dump and sweep ash into ashpan (all stoves). 	<ul style="list-style-type: none"> • Remove fireback and clean vertical exhaust duct. • Open access panel on each side and clean the horizontal exhaust duct. • Remove exhaust blower and clean exhaust duct, blower housing and blower fan. • Clean the vacuum hose barbed connection. • Remove auger cover and vacuum out auger flight. • Remove auger and clean lower auger bearing. • Remove convection blower and clean. • Clean pellet vent. • Check gasketing and replace as necessary <ul style="list-style-type: none"> - Door Gasket - Side Access Panel Cover Gasket - Blower and Blower Housing Gasket - Ash Pan Gasket • Door closure and adjust as necessary. • Check glass door air wash openings and clean as necessary

TRAVIS INDUSTRIES PELLET PRODUCTS



Pellet Appliance Annual Service Procedure

Name _____ Phone # _____
 Address _____
 City _____ State _____ Zip _____
 Appliance Brand _____ Model _____

Check Procedure	✓	Comments Corrections or Recommendations
Check Clearance to Combustibles		
Check Vent for Blockage, Soot or Ash		
Check Outside Air for Blockage		
Clean Vertical Exhaust		
Clean Fire Back		
Clean Burn Pot		
Clean Heat Exchanger Tubes		
Take Apart and Clean Exhaust Blower		
Remove and Clean Convection Blower		
Dust/Vacuum Inner Appliance Body		
Clean Ash Traps and Ash Pans		
Clean Glass		
Check Door Gasket & Glass Gasket		
Check Ashpan Gasket		
Check Horizontal Side Cover Gaskets		
Check Exhaust Blower Gasket		
Cycle Unit and Check Control Board, Auger Motor, Snap Discs and Flow Switch		
Check Convection Blower Turn Up/Down		
Check Feed Rate Turn Up/Down		
Check Wall Trim Seal		
Check Roof Flashing Seal		
Remove Log & Clean		
Check Thermostat Operation		
Check Remote Operation & Replace Batteries		
Check Door Alignment		
Pellet Hopper Lid, Operation		
Finish/Looks Touch-Up		
Clean Hopper/Check for Pellets		

TRAVIS INDUSTRIES PELLET PRODUCTS



Homeowner Questions About Operations:

Appliance Concerns:

Recommendations:

Date _____ Serviced By _____

Company _____

This Annual Service Was Reviewed With Me

Homeowner Signature

Next year's Service Appointment:

Month _____ Date _____ Time _____

TRAVIS INDUSTRIES INSTALLATION



Ladder Safety

Tools

Installation Practices

Roof Pitch

Ceiling Penetration

Ladder Safety

- Locate best access place
 - Check with customer for permission
- Watch for electrical lines
- Use toes/90° arm method to determine correct angle
- Use two hand contact when climbing
- Tie off the ladder at the top
- Ladder should extend at least three rung above the roof edge
- Invest in ladder levelers
- **Use only type I or type II ladders**

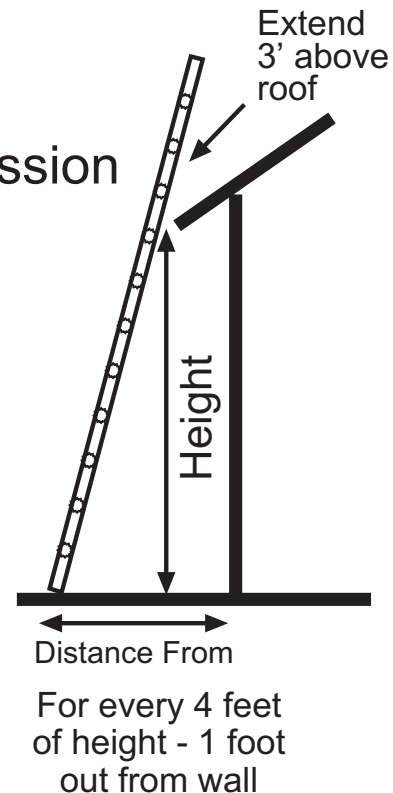

Roof Safety

- Keep electrical cords from under feet
- Use a safety harness where appropriate
- Never throw anything off the roof
- Keep parts and tools from rolling /blowing off

Power Tool/Extension Cord Safety

- Make sure all tools and extension cords are properly grounded. (GFI) Ground Fault Interrupter cords are recommended for outdoor use
- Make sure all tools are in good working order and kept clean
- Make sure all guards are in place and working

Personal Safety

- Protect soot from contacting skin.
- Wear gloves for protection from sharp edges
- Eye protection
- Shoe/boots with soft soles for roof climbing.
- Ear protection
- Lifting belt

Installation Tools

- Invest in the right tool to do the job
- Invest in good tools as they will perform better and last a lifetime
- Make sure your tools and equipment are kept clean and well maintained
- Bring industrial quality tools and equipment into your customers' home will allow you to charge more for your services
- **If necessary** invest in **your future** by buying your tools

Installation Tools

Installation Tools:

- Pry bars
- Tape measure
- Plumb bob
- Chalk line
- Torpedo level
- Stud sensor
- Combination square
- Utility knife
- 5 blade crimping pliers
- Hand seamer pliers
- Hammer
- Roofing nail pry bar
- Aviation snips
- Tin snips
- Pipe snips
- Caulking gun
- Tile breakers and rod
- Vinyl siding tools
- Dry wall hand saw
- 1" wood chisel
- Staple gun
- Masonry drill and 7/8" masonry drill bit
- Electricians knockout punch
- 72" flexible drill bit
- Wire sock for above
- Metal drill bit set
- Center punch
- 7/8" wood drill bit
- Rivet gun
- Strap wrenches
- Compass beam (Large circle compass)
- Stud finder

Gas Piping Tools:

- Tubing cutters - regular & mini
- Flaring tool
- Tube bending tool
- 1/2" & 3/4" pipe threaded
- Thread cutting oil
- Pipe cutter
- Unbilt or pipe reamer
- 1/2" & 3/4" pipe extractor
- Pipe vice
- Metal file
- Pipe caddies for nipples
- Pipe fitting bucket organizers
- Pipe joint compound - make sure it is approved for propane gas
- Teflon tape
- Pipe wrenches - 8", 10", 12" & 14"
- Hacksaw/mini hacksaw
- Air pressure test gage
- Air pressure test gage adaptors
- Portable air tank or air compressor
- Liquid leak detection fluid

Installation Tools

Power Tools:

- Reciprocating saw (wood and metal cutting blades)
- Heavy gage extension cords
- Cordless drill (extra battery)
- Circular saw (wood and masonry blades)
- Masonry hammer drill

Safety Equipment:

- Lift belt
- Safety glasses
- Safety harness (fall protection)
- GFI (ground fault interrupter outlet)
- Ear plugs
- Ridge hook
- Ladder levelers
- Fire extinguisher

Convenience:

- Hand truck
- Stove lift/stair climbing equipment
- 20' extension ladder
- FM - communication head set
- 6' step ladder
- Insert puller
- 4 wheel furniture dolly
- Knee pads

Customer Home Protection:

- Drop cloth
- Rug runners
- Shop vacuum
- Vinyl gloves
- Denatured alcohol
- Broom
- Hand broom/dust pan
- Carpet sweeper
- Waterless hand cleaner
- Disposable coveralls
- Soot sponge

Tile & Masonry Installation:

- Brick hammer
- Masonry chisel
- 1/4" & 3/8" Tuck pointing trowel
- Brick trowel
- 6" x 2" Utility trowel
- Brick jointer 3/8" x 1/2"
1/2" x 5/8" & 5/8" x 3/4"
- Small Tuck pointing trowel
- Tuck pointers plugging chisel
- 5 gallon pails
- Grouting trowel
- Tile nipper
- Tile/marble saw
- Screeting trowel
- 24" Masons level
- Masons brush
- Skate wheeled joint raker
- Mixing paddle

Installation of Travis Industries Products

- **Read** Travis Industries installation directions
- **Follow** Travis Industries Installation directions
- **Failure** to follow Travis Industries installation directions may result in:
 - ➔ Poor appliance performance
 - ➔ Voiding of listing and or warranty
 - ➔ Your assumption of all liability

➔ **LOSS OF PROPERTY
AND/OR LIFE**

Installation of Travis Industries Products

- Know Your Markets Requirements
 - ✓ Building Permit Required
 - ✓ Final Inspection Required
 - ✓ License Requirements
 - Venting
 - Gas Piping
 - Electrical
 - ✓ Which codes and/or standards apply
 - Local
 - County
 - State
 - Code Bodies

Installation of Travis Industries Products

- Use only Travis Industries specified, listed and tested components
- Do not modify product/components unless authorized by Travis Industries
- Follow Travis Industries Prescribed.....
 - ➔ Clearance to Combustibles
 - ➔ Venting Parameters
 - ➔ Placement
 - ➔ Venting Termination
 - ➔ Finalizing the Installation

Installation of Travis Industries Products

When reading Travis Industries Installation Directions, pay particular attention to the following:

- ✓ Items required for installation
- ✓ Stove/insert/fireplace clearance
 - Framing
 - Adjacent walls
 - Ceiling
 - Mantels and decorative trim
- ✓ Stove/insert/fireplace placement requirements
- ✓ Floor protection requirements

Typical Breakdown of All Travis Installation Manuals

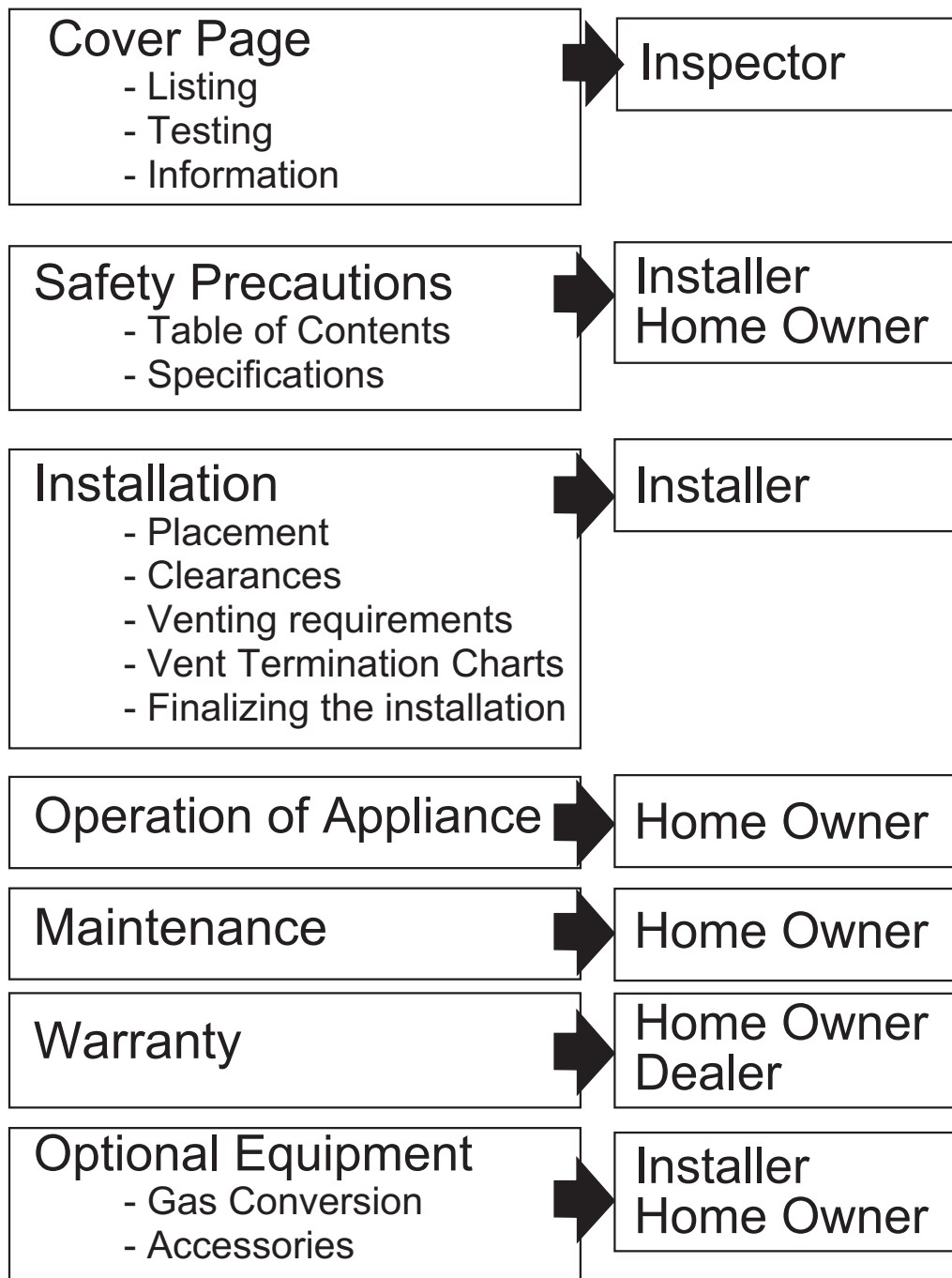

Roof Pitch

- Rise in inches per foot of run

Common Pitches:

4/12 Pitch

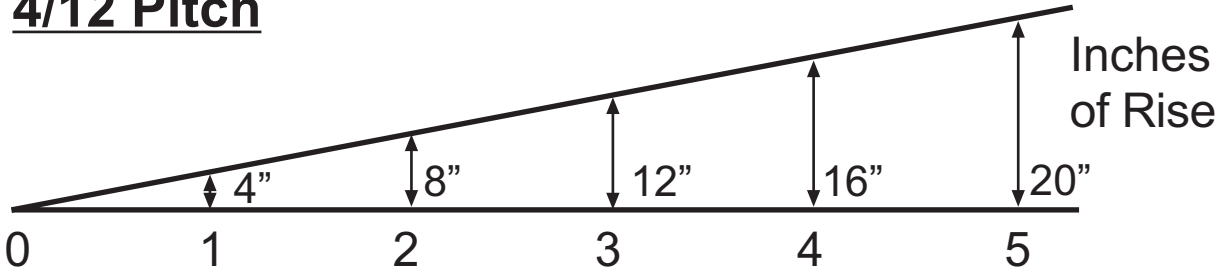

6/12 Pitch

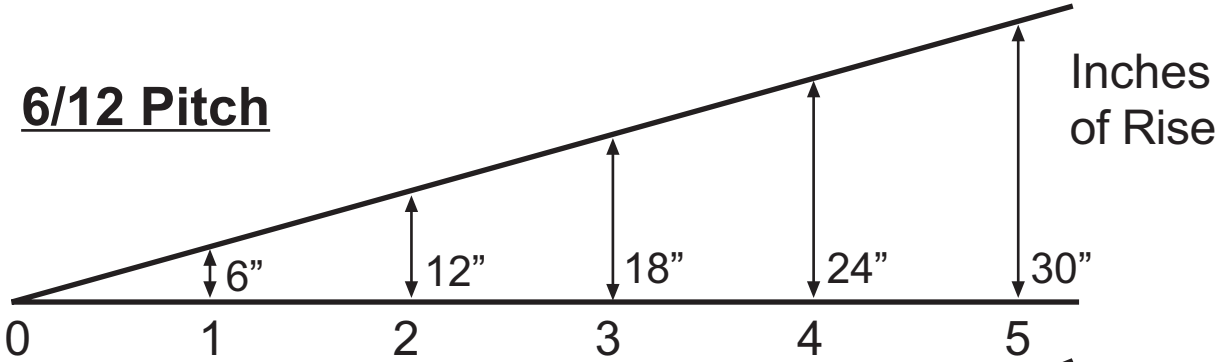

12/12 Pitch

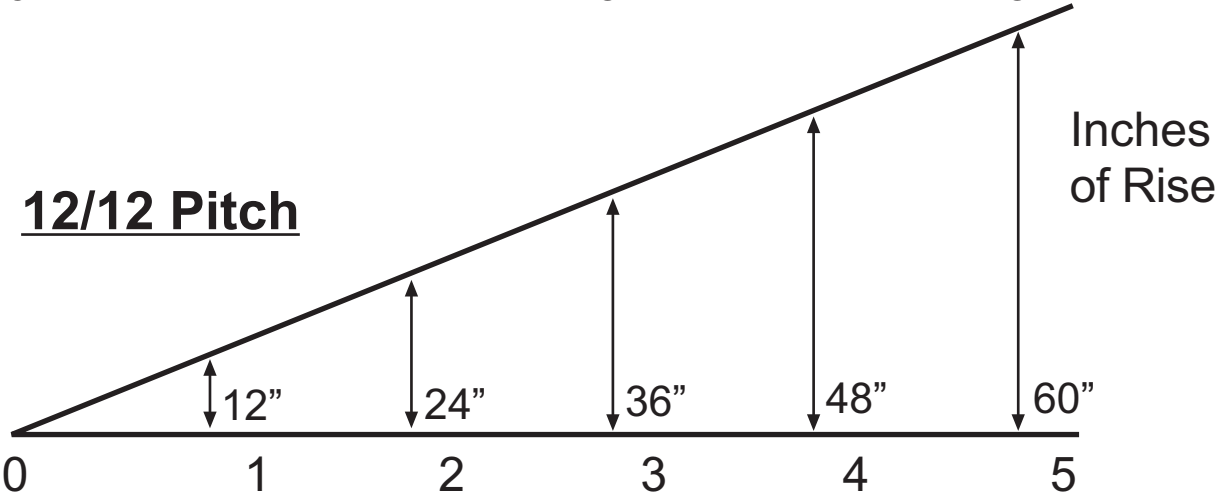

Roof Pitch

- Calculate: 3' -2' -10' Chimney Requirements for Wood Burning Chimney

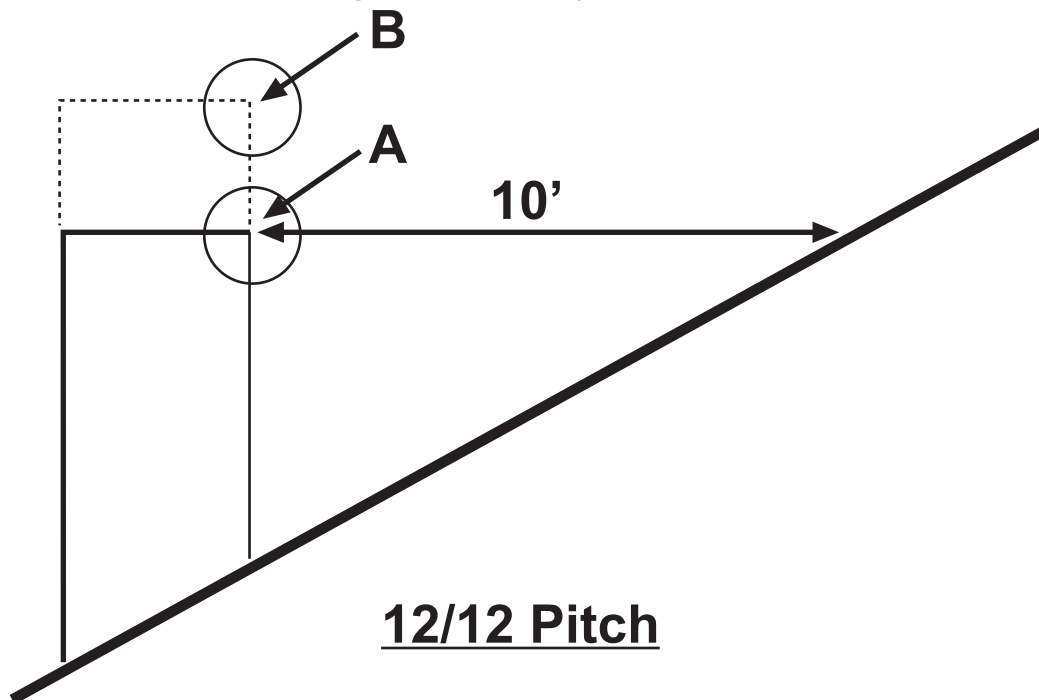

- Chimney must be 2' higher than any roof portion within 10' and be a minimum of 3' above the roof
- $10' \times 12'' = 120''$ Point A = 120"
 $120'' + 24''$ (2 foot above) = 164" above roof

Roof Pitch

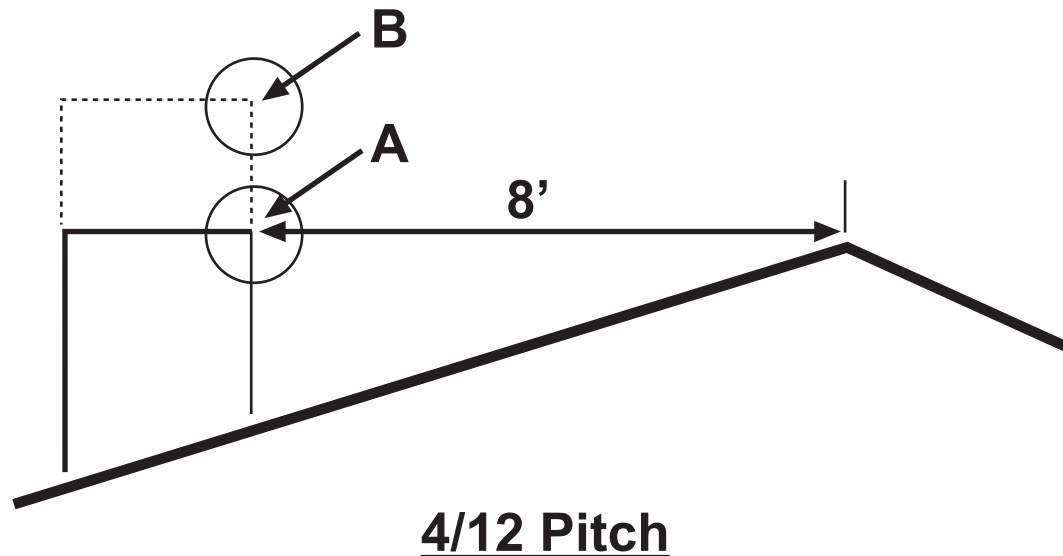

QUESTION

What amount of chimney must be extended above the roof line to satisfy the 3' - 2' - 10' chimney rule

A =

B =

Measuring Roof Pitch

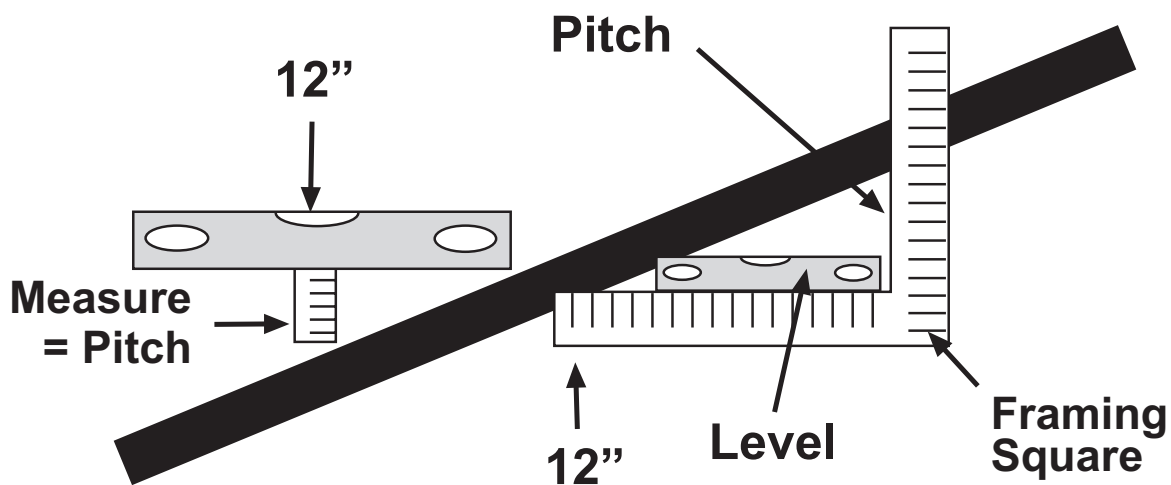

Outside Roof Line

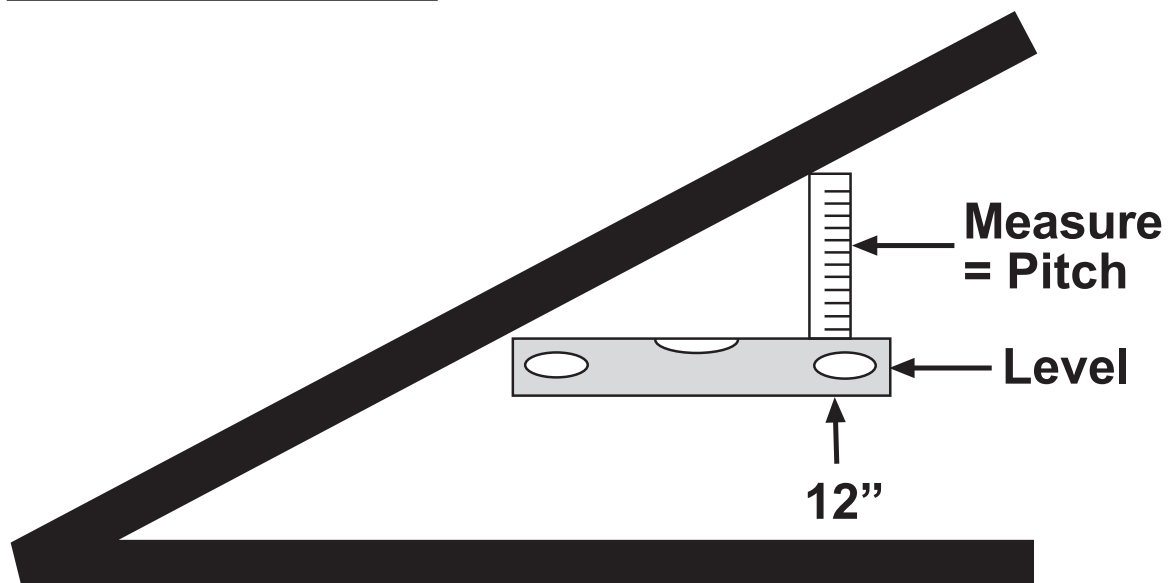

Inside Attic Space or Cathedral Ceiling

Measuring Roof Pitch

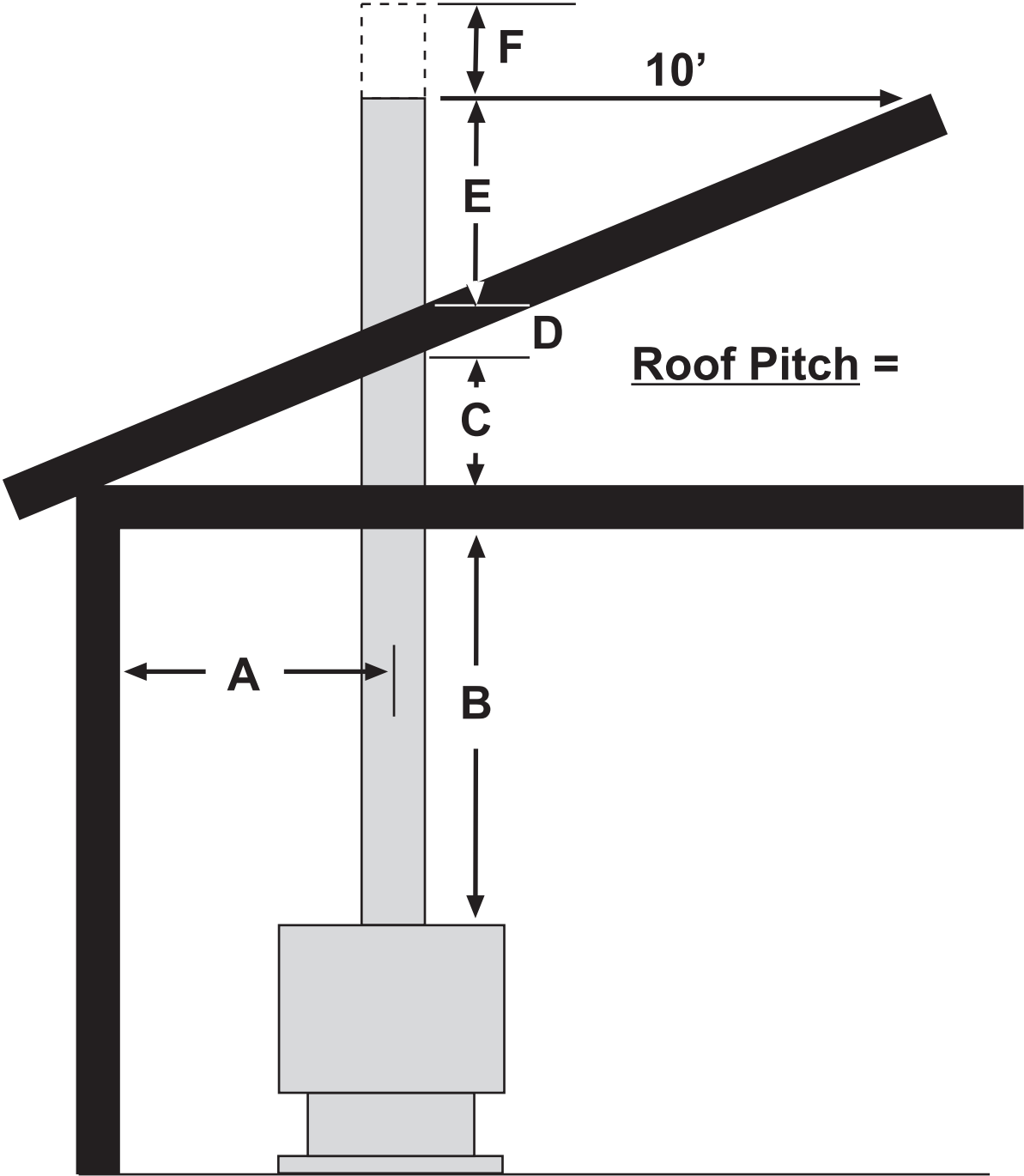

Passing Through the Ceiling and Roof

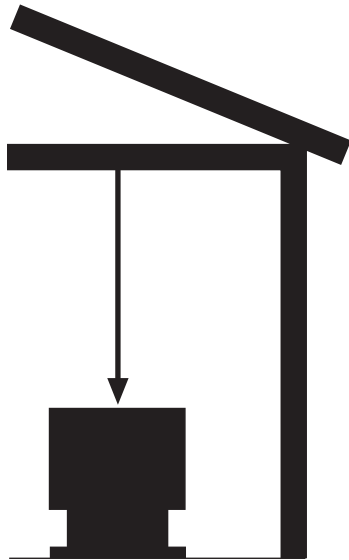

1. Plumb to ceiling and mark ceiling.

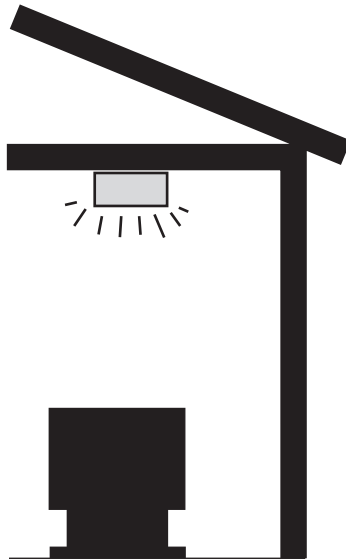

2. Locate ceiling joist with stud finder - relocate center and mark as necessary. (Keep stove clearances in mind)

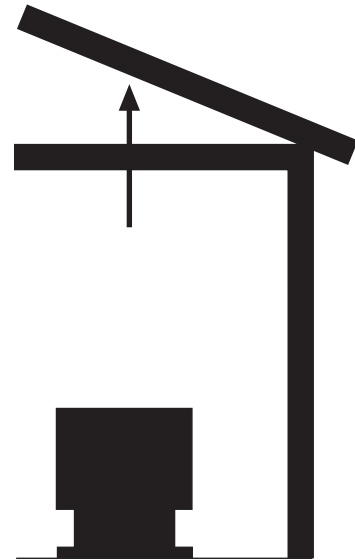

3. With a coat hanger, drill into the attic space. If possible access attic space. Check for any obstructions (Ducting, piping, wires)

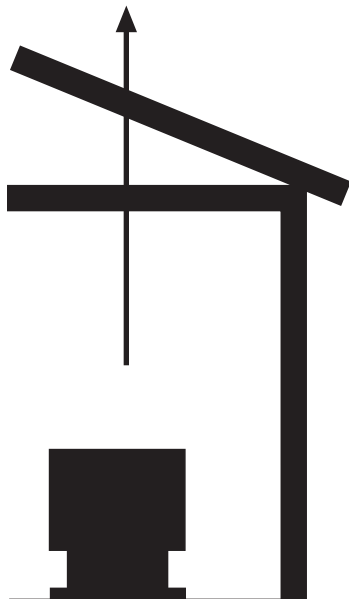

4. Plumb or drill through roof. (Plumb - drive nail)

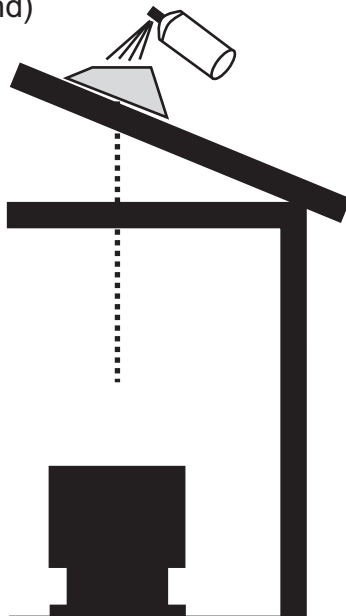

5. Center flashing. Spray paint inside opening.

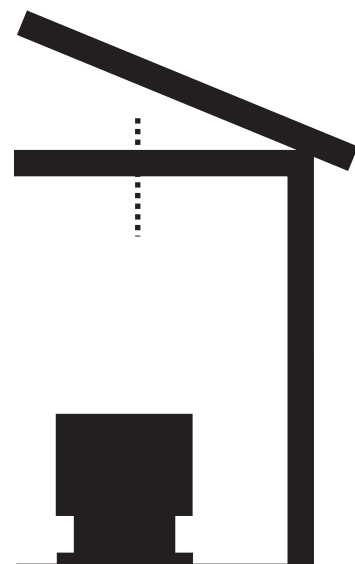

6. Mark ceiling with template

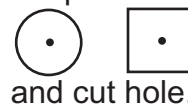

and cut hole.

Passing Through the Ceiling and Roof

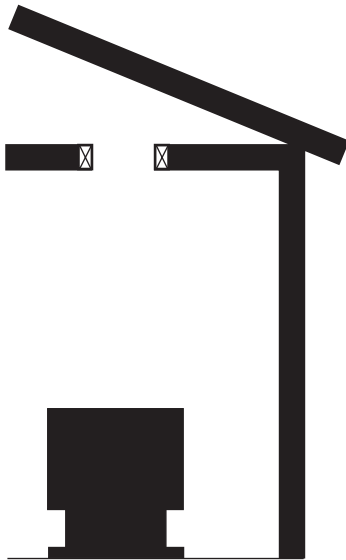

7. Frame opening with 2 x 4 and right angle Simpson brackets

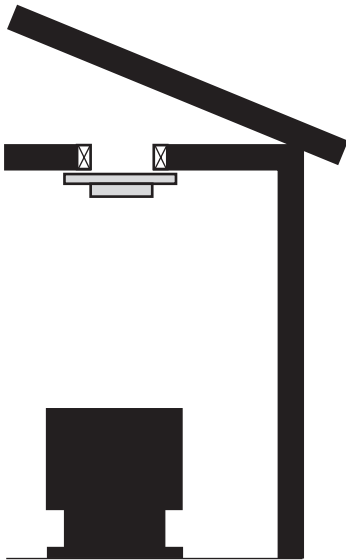

8. Install ceiling support

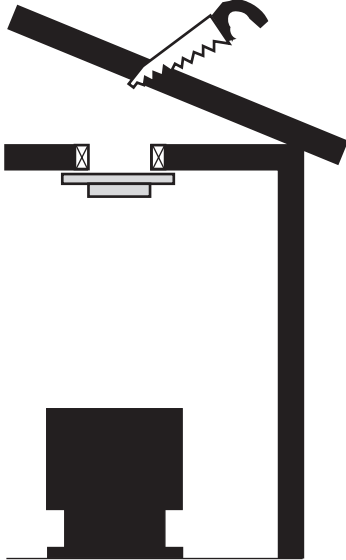

9. Cut hole in roof with saw

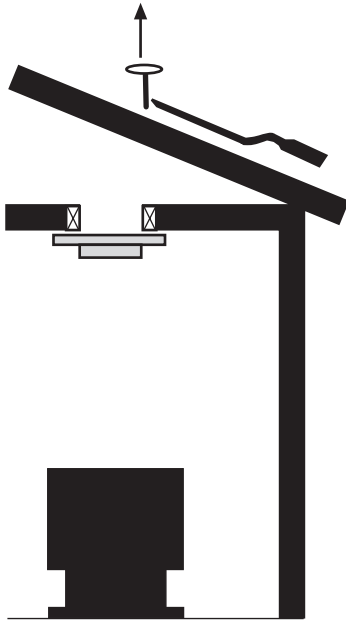

10. Loosen and remove roofing nails

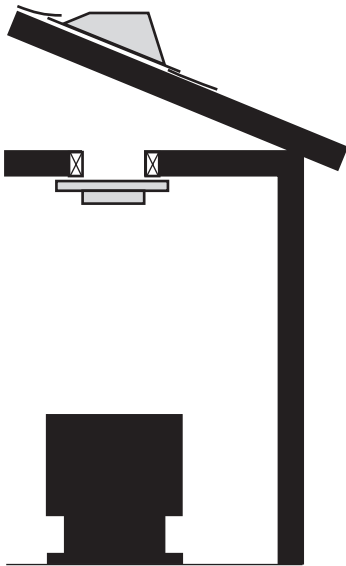

11. Slip flashing under shingles as necessary

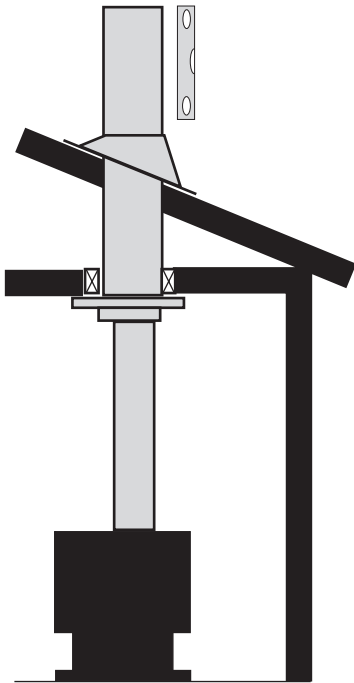

12. Install pipe - LEVEL - Nail flashing & shingles - and install connector pipe. Install storm collar - caulk storm collar

Passing Through the Ceiling and Roof

- **AVOID CUTTING THROUGH...**
 - Ceiling Joists
 - Rafters
 - Support Beams
 - Trusses
- Talk to the customer about alterations
- Walk if necessary

Calculating the Hypotenuse of a Right Triangle

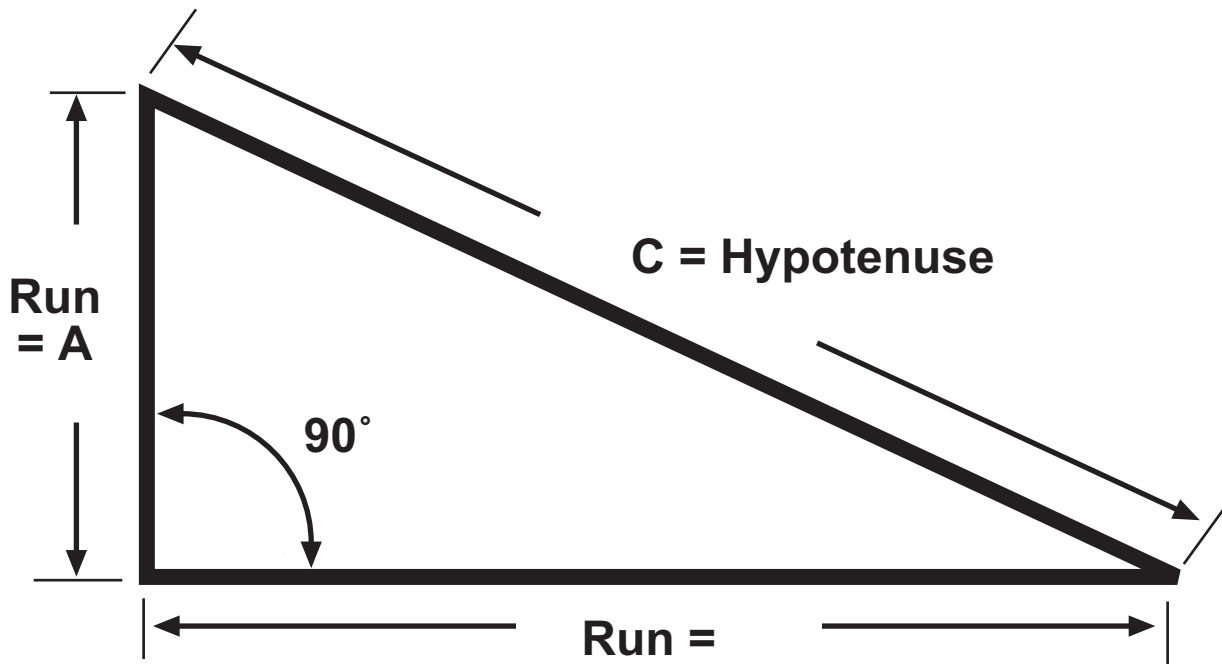

$$A^2 + B^2 = C^2$$

- $A = 6''$
- $B = 10''$

$$\begin{aligned} A^2 + B^2 &= C^2 \\ (A \times A) + (B \times B) &= C^2 \\ (6 \times 6) + (10 \times 10) &= C^2 \\ 36'' + 100'' &= C^2 \\ \sqrt{136''} &= C^2 \\ 11.66 &= C^2 \end{aligned}$$

Calculating Length of the Roof Cutout

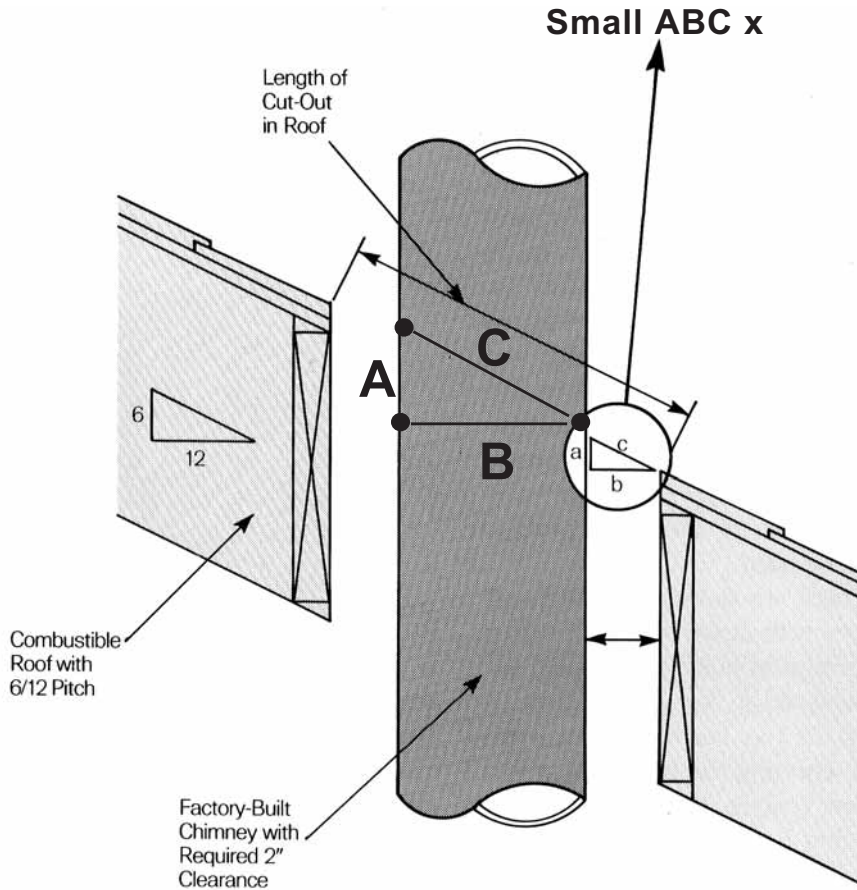

Small ABC

$$A^2 + B^2 = C^2$$

A - Unknown

B - 2"

C - Unknown

Pitch - 6/12

$$A/2 = 6/12$$

$$\uparrow \times \downarrow$$

$$12A/2 = 6$$

$$\uparrow \times \downarrow$$

$$12A = 12$$

$$\uparrow \div \downarrow$$

$$A = 1$$

$$A^2 + B^2 = C^2$$

$$(A \times A) + (B \times B) = C^2$$

$$(1 \times 1) + (2 \times 2) = C^2$$

$$1 + 4 = C^2$$

$$5 = C^2$$

$$2.23 = C$$

Large ABC

$$A^2 + B^2 = C^2$$

A - Unknown

B - 12"

C - Unknown

Pitch - 6/12

$$A/12 = 6/12$$

$$\uparrow \times \downarrow$$

$$12A/12 = 6$$

$$\uparrow \times \downarrow$$

$$12A = 72$$

$$\uparrow \div \downarrow$$

$$A = 6"$$

$$A^2 + B^2 = C^2$$

$$(A \times A) + (B \times B) = C^2$$

$$(6 \times 6) + (12 \times 12) = C^2$$

$$36 + 144 = C^2$$

$$180 = C^2$$

$$\sqrt{180}$$

$$C = 13.41$$

Small C Plus

Big C Plus

Small C =

Length of Roof Cut Out

2.23 - Small C

13.41 - Big C

2.23 - Small C

17.87

or

17 7/8"

Calculating Support Box Length

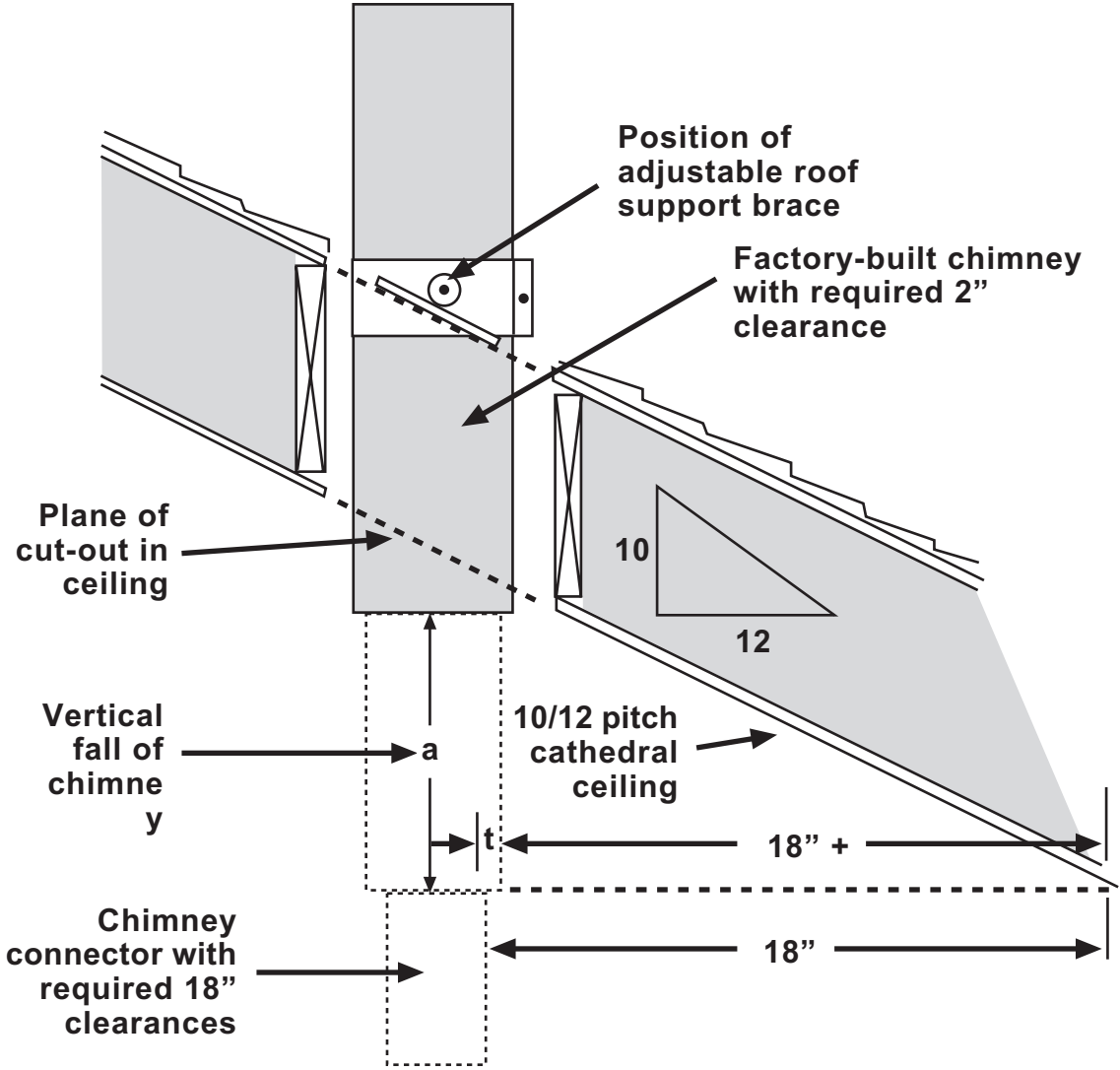

A = Unknown
B = 18 -+
C = Unknown
+ = 1.5"
Pitch 10/12

$$A/16.5+ = 10/12$$

$$\leftarrow x \rightarrow$$

$$12A/16.5 = 10$$

$$\leftarrow x \rightarrow$$

$$12A = 165$$

$$\leftarrow \div \rightarrow$$

$$A = 13.75"$$

3 Foot - 2 Foot - 10 Foot Rule

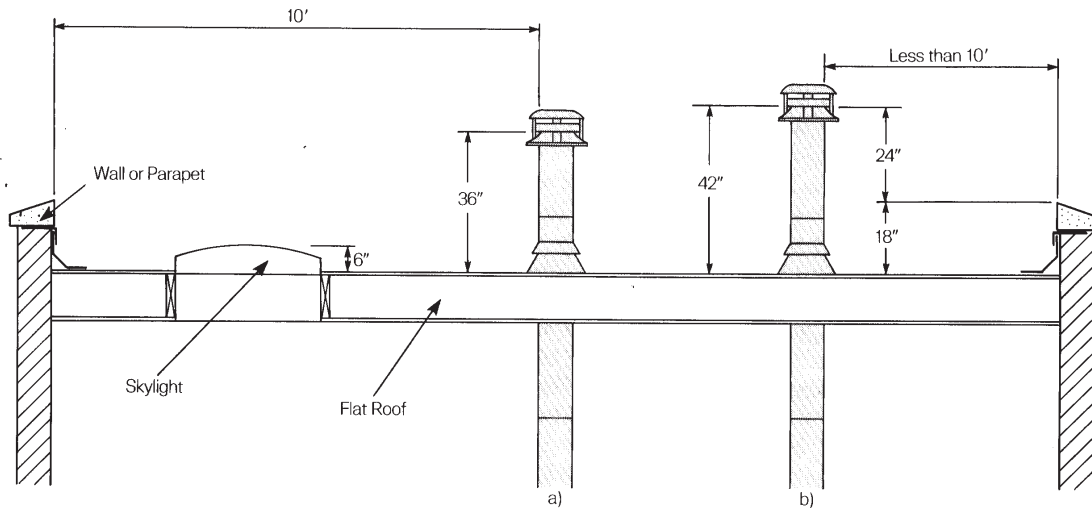



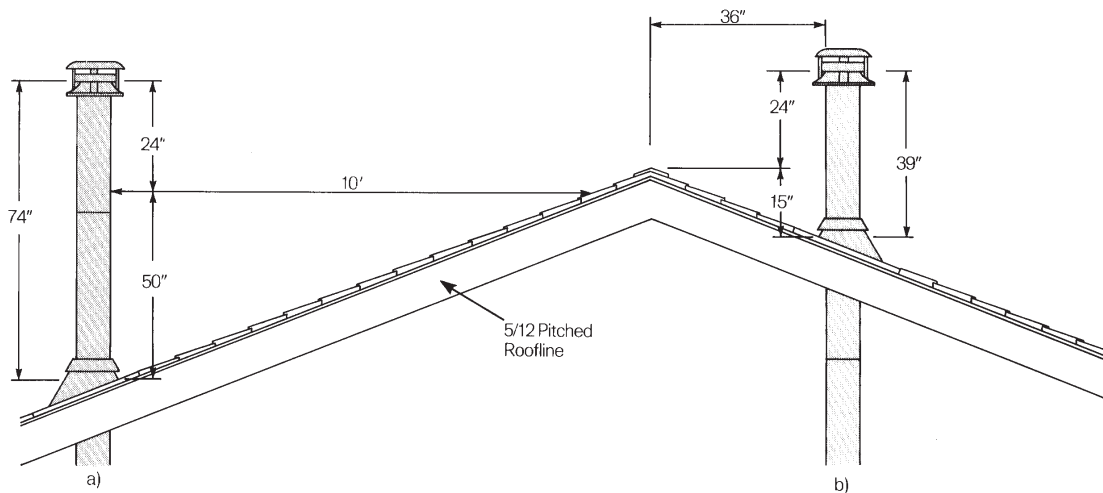

CALCULATING CHIMNEY HEIGHTS WITH FLAT ROOFS (Example with 18" Parapets)

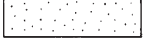
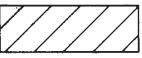

Typical Insulating Values

TYPICAL INSULATING VALUES OF HEARTH MATERIALS

Typical Hearth Extension Materials	Ceramic Fiber Millboard	Mineral Fiber Millboard	Ceramic Tile, Stone*	Face Brick*	Common Brick, Cement Mortar*
k Value (per inch) (BTU-in/ft ² hr F°)	0.56	0.84	12.50	9.00	5.00
r Value (per inch) (1/k)	1.78	1.19	0.08	0.11	0.20
Typical Standard Thickness	0.50"	1.00"	2.00"	2.50"	4.00"
					
R value (actual) (r × thickness)	0.89	1.19	0.16	0.28	0.80
Thickness of material having R value = 1.78 (1.78/r)	1.00"	1.50"	22.00"	16.00"	9.00"

* The insulating value of most masonry materials (including tile, brick, stone, concrete, cement), is minimal. In using traditional masonry hearth materials, it is often necessary to use in combination with an insulating board of appropriate k or R values as per the manufacturer's specifications.

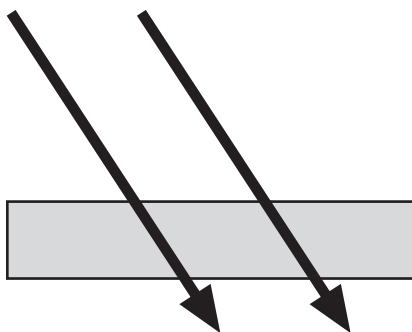

k-Value

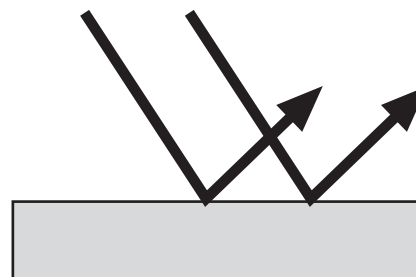

r-Value

WOOD LAB

Hands On Lab Sheet

Required Activity

1. Install Vent System
2. Draw Up Venting For Wood Stove Installation
3. Draw Up Cooling Vent For FPX Wood Fireplace
4. Install Blower On FPX Wood Fireplace
5. Set Up Of Electric Fireplace Or Stove
6. Operating Electric Fireplace Or Stove

Elective Activity

1. Outside Air Kit Installation
2. Front and Rear Blower Installation
3. Ceiling Penetration Installation
4. Fireplace Summer Switch Installation
5. Fireplace Blower Connections & Extensions
6. Stud Finders, Drill Spotters and Laser Centers and Other Helpful Ideas
7. Testing Door Gasket and Door Adjustment
8. Air Tube Replacement
9. Glass Replacement
10. Bypass Control Replacement
11. Brick Replacement - Baffle Support Replacement
12. Catalytic Combustor Removal and Cleaning
13. Blower Circuit Testing
14. Electrical Outlet Testing

PELLET LAB

Hands On Lab Sheet

Required Activity

1. Check Control Board Small or Large Setting
2. Check If Everything Works First
3. Troubleshoot Pellet Board 12 Switches
4. Check Answers On Pellet Board Problems
5. If Any Wrong Answers Go Back and Find Out Why
6. Thermostat Operation and Testing
7. Tear Down Pellet Stove and Reassemble
8. Installing Restrictor Upgrade On Small Stove
9. Pellet Stove Component Test Board
10. Electric Circuit Testing
11. Pellet Vent Installation Through The Wall
12. Pellet Vent Installation Vertical

Elective Activity

1. Remote Control Operation
2. Thermostatic Operation
3. Large Stove Igniter Replacement
4. Auger Jam Removal
5. Outside Air Kit Installation
6. Through the Ceiling Installation
7. Restrictor Adjustments
8. Modulating Remote Installation
9. Electrical Outlet Testing
10. Adjustable Pellet Hopper (insert)

TRAVIS INDUSTRIES LAB ACTIVITIES



Pellet Troubleshooting Burner Activity Page

Tear out and record your answers

Switch #	What Doesn't Work	Start Mode or Run Mode	Describe Testing Procedure	Defective Component
1.				
2.				
3.				
4.				
5.				
6.				
7.				
8.				
9.				
10.				
11.				
12.				

Electrical Outlet Testing Exercise

Test outlets A-E with the outlet analyzer and record your findings.

- A.
- B.
- C.
- D.
- E.

Using the circuit finder match the following outlets to the proper circuit breakers.

A. _____

1.

B. _____

2.

C. _____

3.

D. _____

4.

Which outlet is connected to the GFCI circuit breaker?

PELLET STOVE Thru-the-Wall Penetration

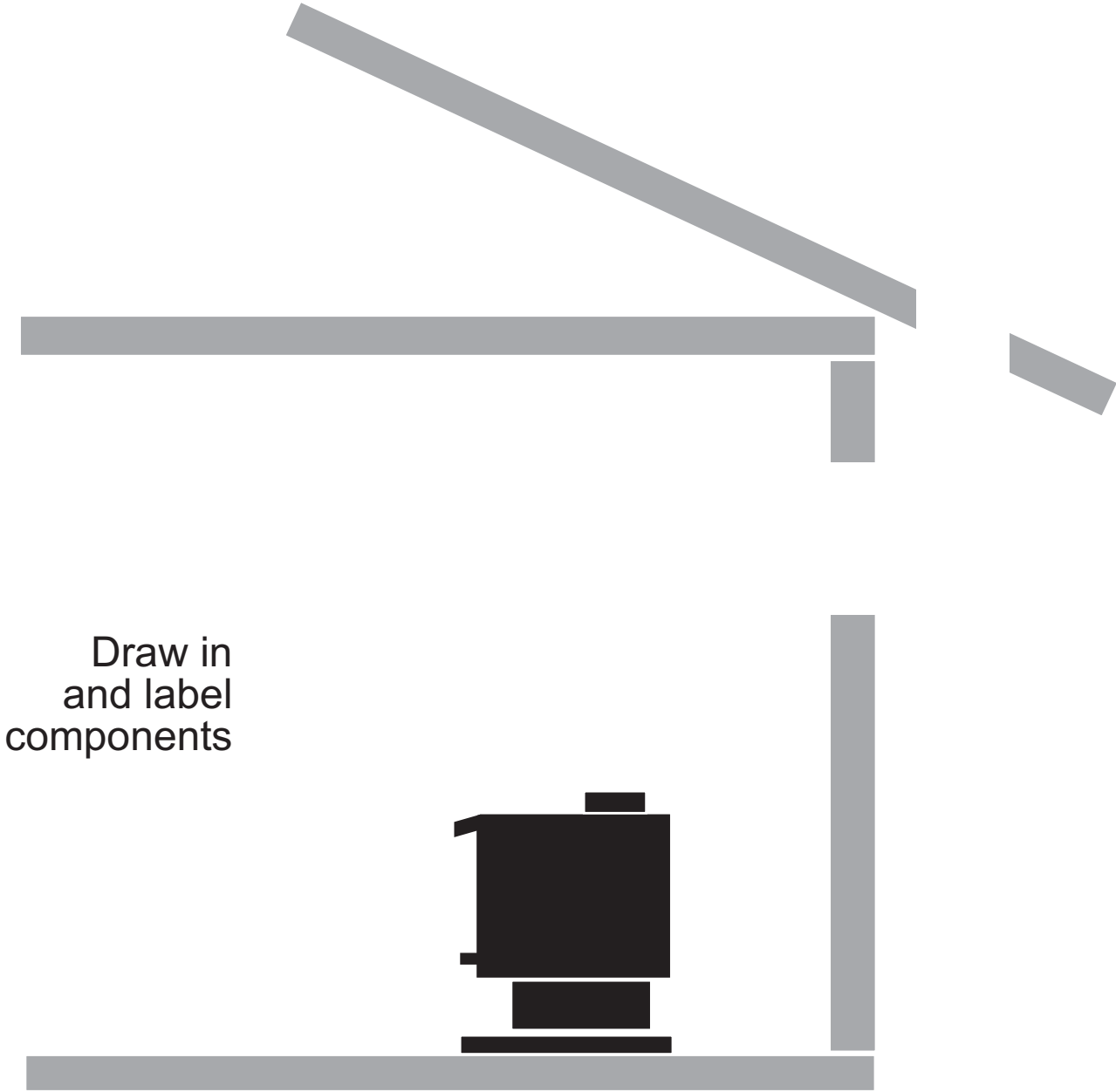

PELLET STOVE Ceiling Penetration

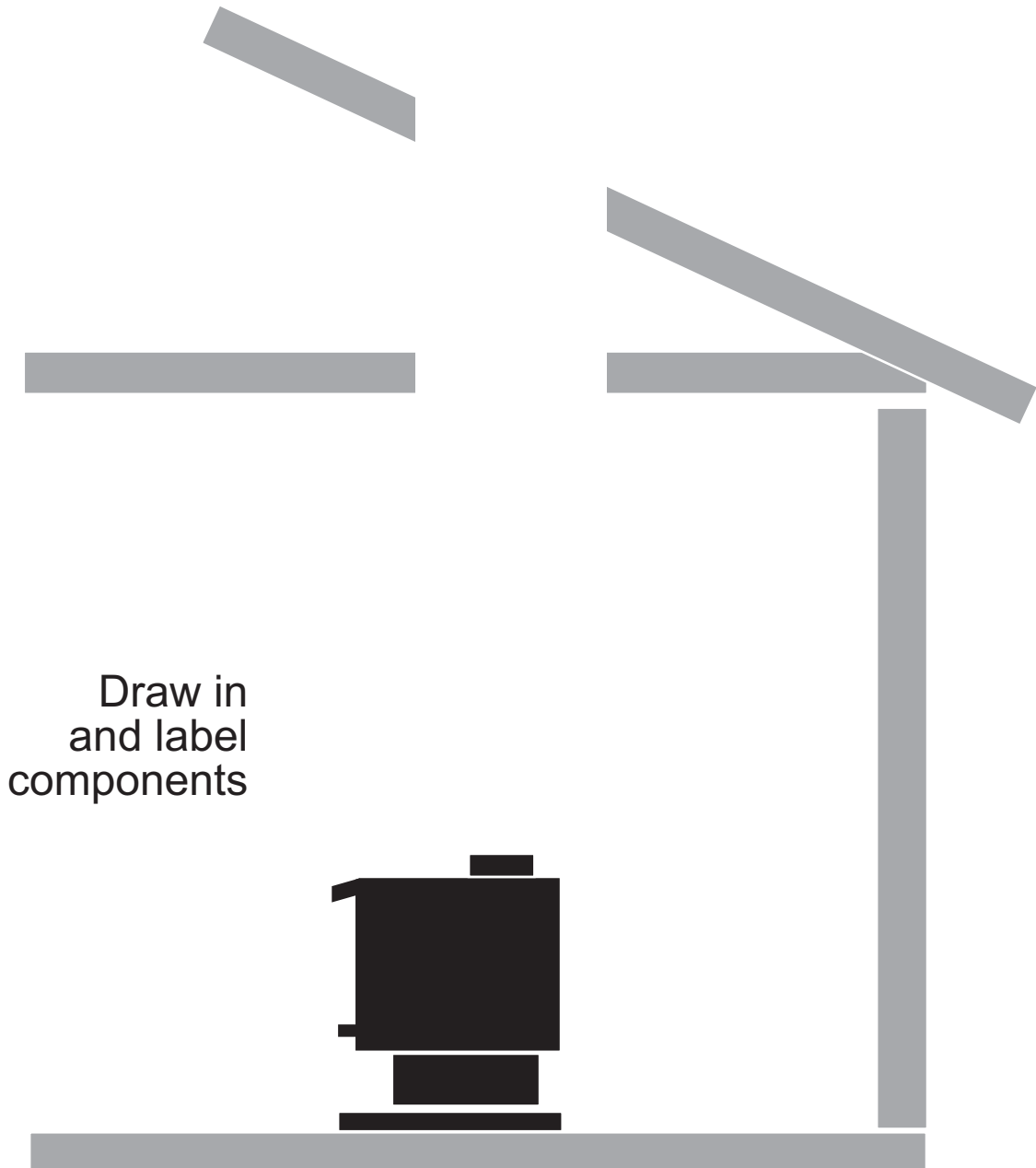

Draw in
and label
components

PELLET STOVE Cathedral Ceiling Penetration

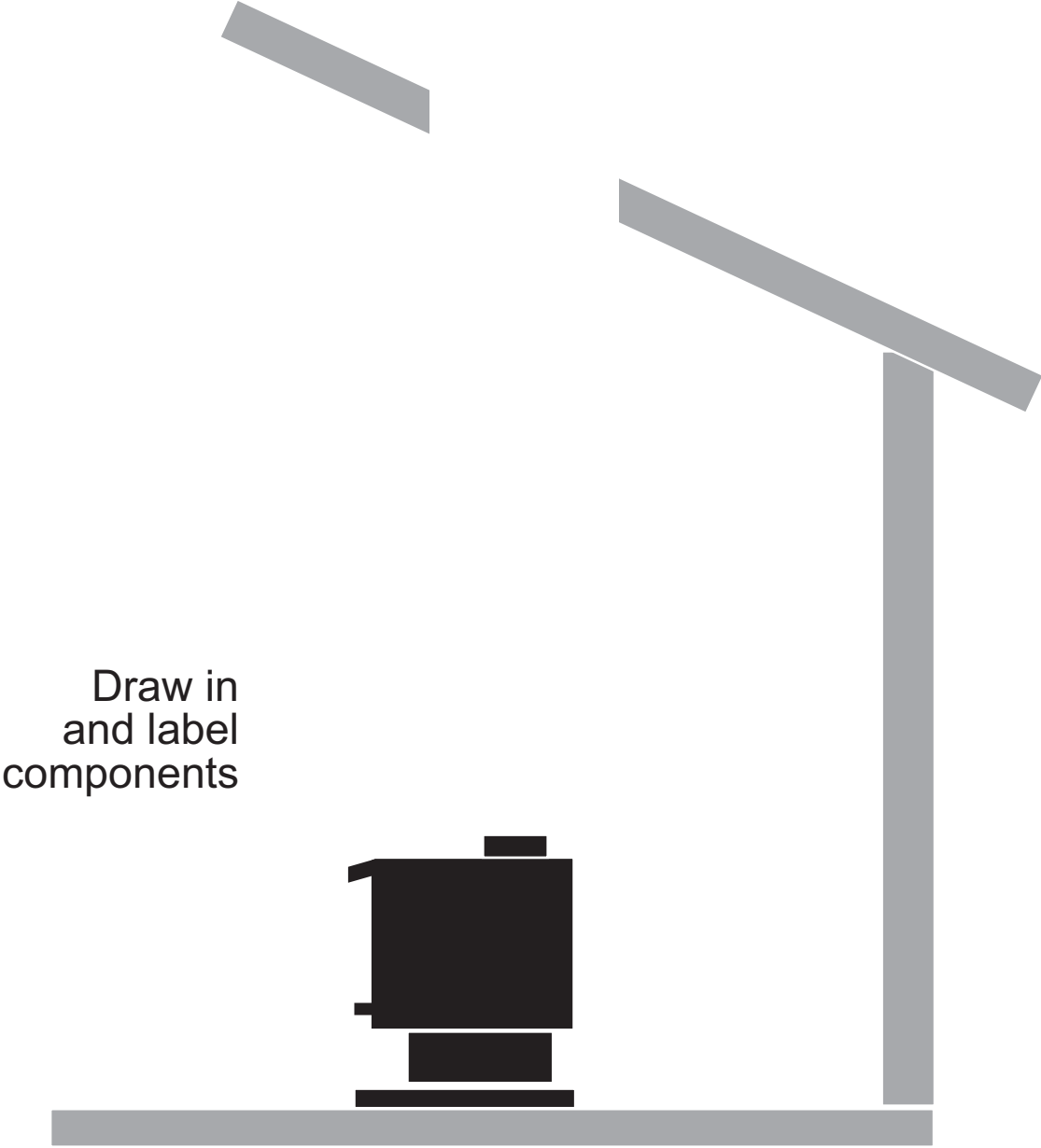

WOOD STOVE Thru-the-Wall Penetration

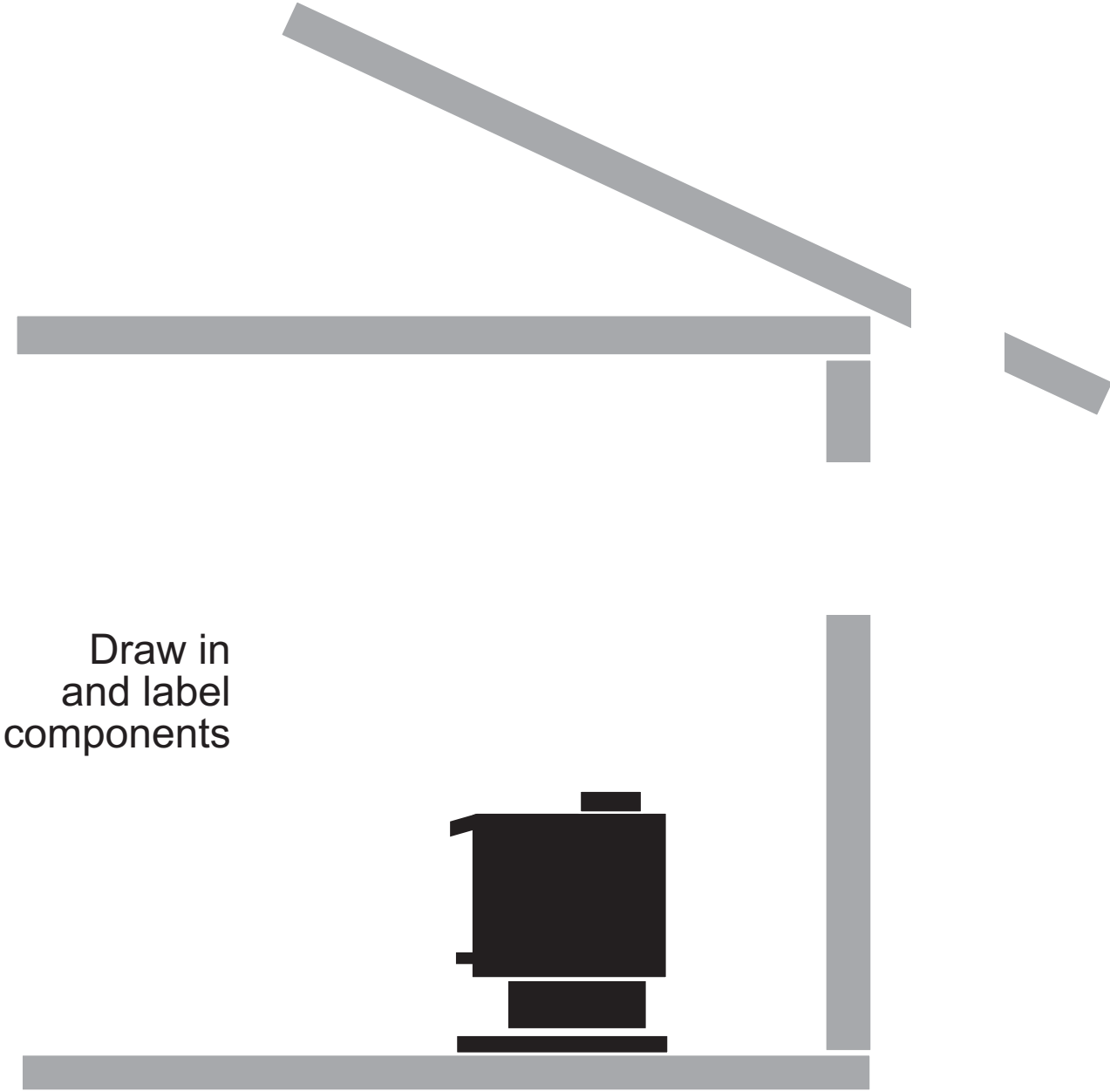

Draw in
and label
components

WOOD STOVE Ceiling Penetration

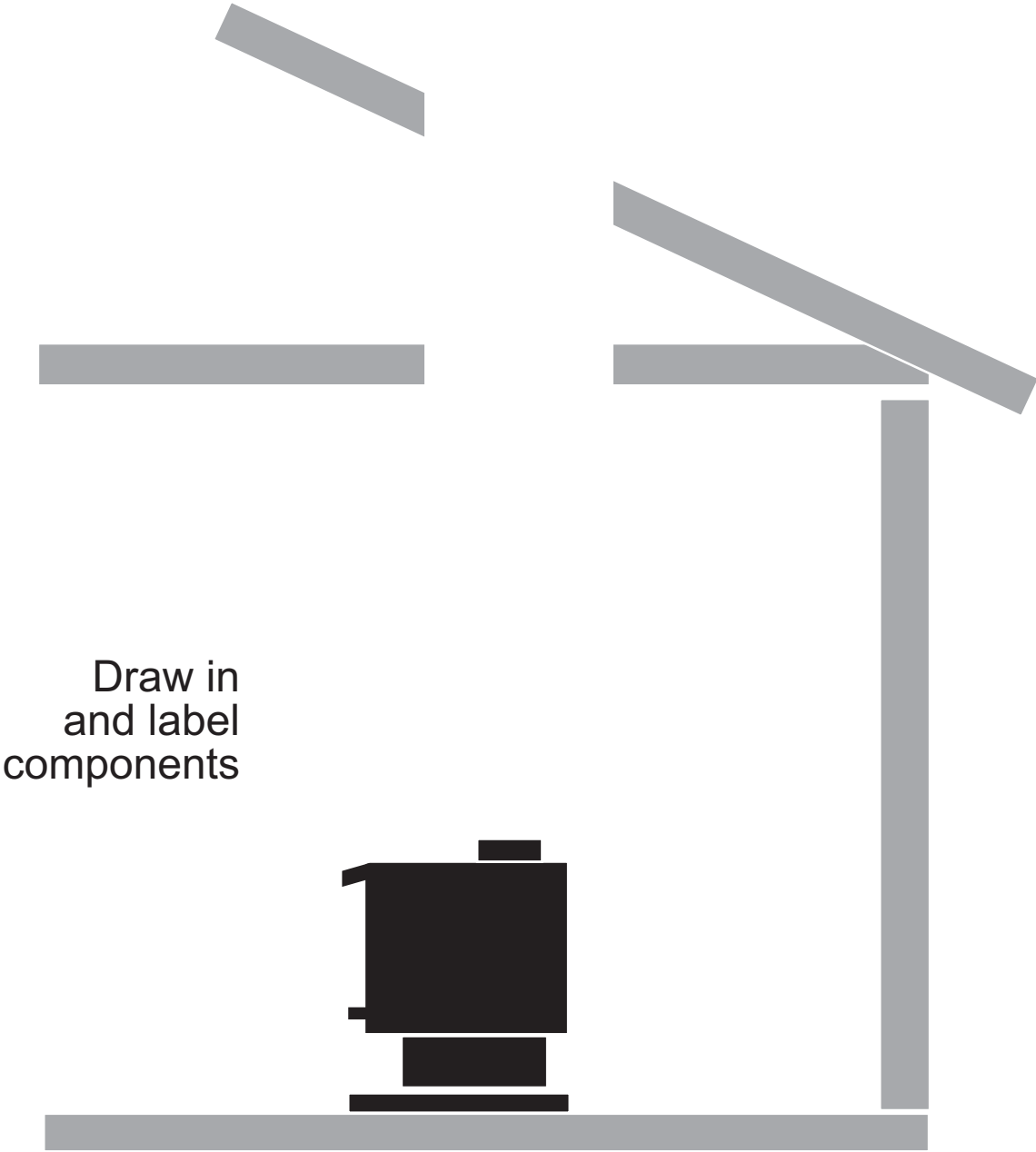

WOOD STOVE Cathedral Ceiling Penetration

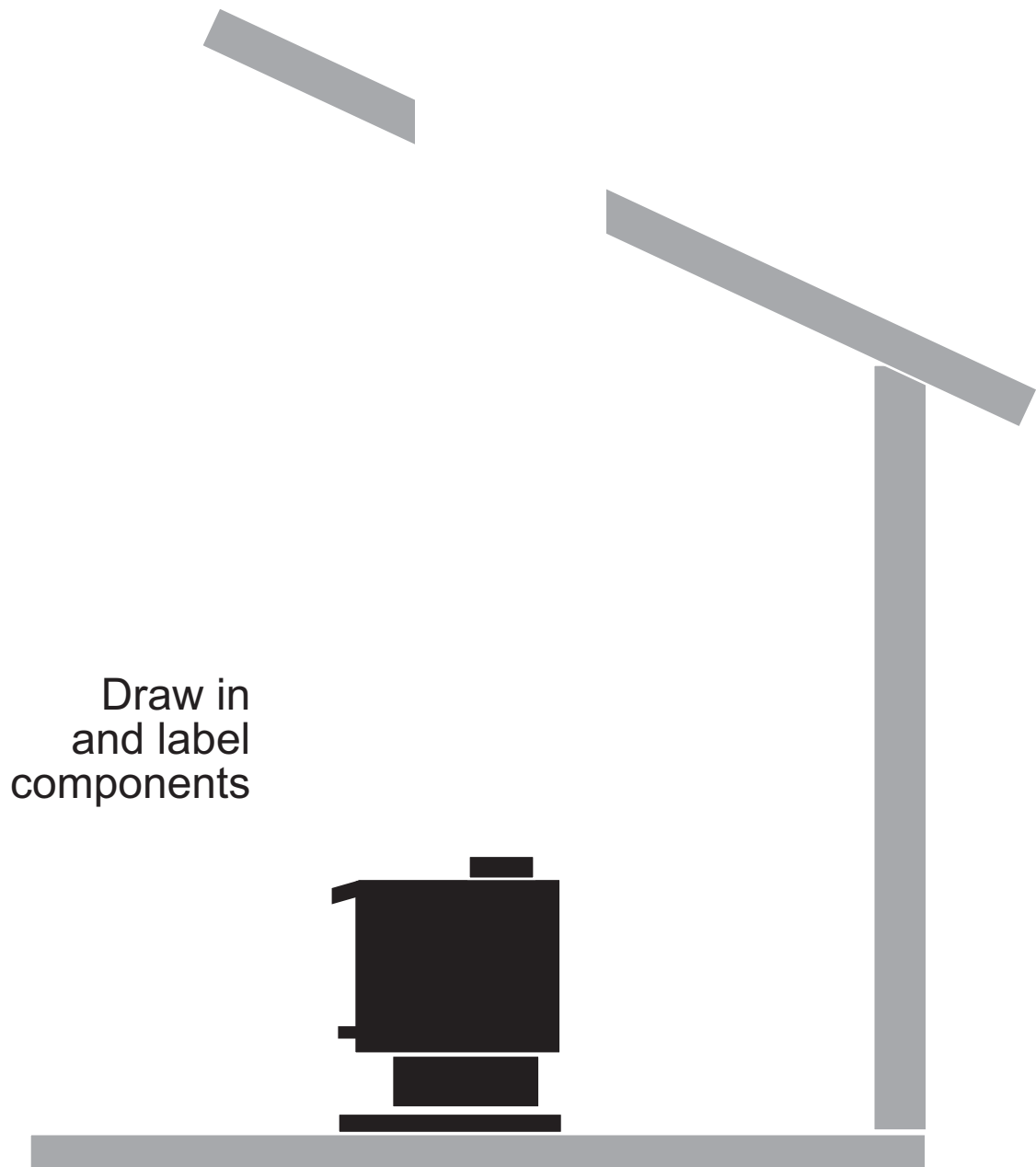

Install One Wood and Pellet Each. More if Time Permits.

1. Wood Stove -

See manual for stove installation instructions

1 - Vertical

1 - Insert

2. Pellet Stove -

See manual for stove installation instructions

1 - Horizontal

1 - Vertical

1 - Insert

Pellet Troubleshooting Answers

Pellet Board

Switch 1 Defective Auger Motor
Switch 2 Defective Snap Disk
Switch 3 Defective Wiring Harness (Ignitor Circuit)
Switch 4 Defective Convection Blower
Switch 5 Defective Systems Disk
Switch 6 Defective Board (Exhaust Blower Circuit)
Switch 7 Defective Board (Ignitor Circuit)
Switch 8 Defective Exhaust Blower
Switch 9 Defective Ignitor
Switch 10 Defective Wiring Harness (Hopper Snap Circuit)
Switch 11 Defective Wiring Harness (Convection Circuit)
Switch 12 Defective Wiring Harness (Black Power Wire)

Thermostat Board

Switch 1 Defective Thermostat
Switch 2 Defective Thermostat Wire
Switch 3 Not Used With The Pellet Testing

REVIEW



Name: _____

Store: _____

Course Title: _____

TRAINING WORKSHOP EVALUATION

Primary Position:

Business Owner

Manager

Salesperson

Installer

Service Technician

Other _____

What was most helpful to you? Why? _____

What was least helpful to you? Why? _____

General Comments About the Training Program _____

What other training topics should we offer? _____

Who Else In Your Organization Might Benefit From This Training

Name _____

Name _____

Name _____

Name _____

Please Circle the Appropriate Numbers

Pre-Study Training Materials

High - 5 4 3 2 1 - Low

Training Displays and Training Aids

High - 5 4 3 2 1 - Low

Hands-On Training Activities

High - 5 4 3 2 1 - Low

Class Met My Expectations

High - 5 4 3 2 1 - Low

Class Room Training Materials

High - 5 4 3 2 1 - Low

Overall Value of Training Course

High - 5 4 3 2 1 - Low

Instructor's Knowledge of Subject Matter

High - 5 4 3 2 1 - Low

Instructor's Delivery and Presentation Style

High - 5 4 3 2 1 - Low

Comments _____

Hotel Accommodations

High - 5 4 3 2 1 - Low

Food and Refreshments

High - 5 4 3 2 1 - Low

How does our training compare to others you have taken?

Much Better Better Same Worse
(Please circle best response)

List Other Manufacturer's Training Course's Taken:

You have my permission to reprint my comments.

Signed _____